



US00D911777S

(12) **United States Design Patent**  
**Spence**

(10) **Patent No.:** **US D911,777 S**  
(45) **Date of Patent:** **\*\* Mar. 2, 2021**

(54) **COOLING CONTAINER INCLUDING AN OUTER CONTAINER AND TWO INNER CONTAINERS**

(71) Applicant: **Kesha Spence**, Clifton, NJ (US)

(72) Inventor: **Kesha Spence**, Clifton, NJ (US)

(73) Assignee: **Kesha Spence**, Paterson, NJ (US)

(\*\*) Term: **15 Years**

(21) Appl. No.: **29/666,721**

(22) Filed: **Oct. 15, 2018**

**Related U.S. Application Data**

(63) Continuation-in-part of application No. 29/552,177, filed on Jan. 20, 2016, now abandoned.

(51) **LOC (13) Cl.** ..... **05-01**

(52) **U.S. Cl.**  
USPC ..... **D7/501**; D7/629

(58) **Field of Classification Search**  
USPC ..... D7/541, 589, 598, 600, 629, 505;  
D9/421; 206/563; 229/904  
CPC ..... B65D 5/48018; B65D 1/36; B65D 5/10;  
B65D 81/3823; B65D 43/0212  
See application file for complete search history.

(56) **References Cited**

**U.S. PATENT DOCUMENTS**

- 2,924,372 A \* 2/1960 Kirkeby ..... B65D 5/48018  
206/563
- D408,222 S \* 4/1999 Carter ..... D7/541
- D464,567 S \* 10/2002 Baerenwald ..... D9/432
- D472,774 S \* 4/2003 Pelstring ..... D7/629
- D474,402 S \* 5/2003 Baerenwald ..... D9/420
- 7,293,695 B2 \* 11/2007 Stier ..... B65D 5/10  
206/564
- D574,189 S \* 8/2008 Stamper ..... D7/505
- D601,381 S \* 10/2009 Stamper ..... D7/505

- D615,822 S \* 5/2010 Klein ..... D7/541
- 7,954,664 B2 \* 6/2011 Cronin ..... B65D 43/0212  
220/819
- D649,869 S \* 12/2011 Gibson ..... D9/421
- D650,267 S \* 12/2011 Gibson ..... D9/428
- D656,789 S \* 4/2012 Locke ..... D7/541
- D659,023 S \* 5/2012 Hsu ..... D9/737
- D688,921 S \* 9/2013 Miros ..... D7/629
- D695,575 S \* 12/2013 Katz ..... D7/629

(Continued)

*Primary Examiner* — Cynthia R Underwood

(57) **CLAIM**

The ornamental design for a cooling container including an outer container and two inner containers, as shown and described.

**DESCRIPTION**

FIG. 1 is a front perspective view of a cooling container including an outer container and two inner containers showing my new design;  
 FIG. 2 is a right side elevational view thereof;  
 FIG. 3 is a left side elevational view thereof;  
 FIG. 4 is a front elevational view thereof;  
 FIG. 5 is a rear elevational view thereof;  
 FIG. 6 is a top plan view thereof;  
 FIG. 7 is a bottom plan view thereof;  
 FIG. 8 is a front perspective view of the outer container with the lid open and revealing the interior, shown with the two inner containers removed for ease of illustration;  
 FIG. 9 is a front perspective view of the first inner container with the lid open, shown separated from the outer container and the second inner container;  
 FIG. 10 is a rear perspective view of the second inner container with the lid open, shown separated from the outer container and the first inner container; and,  
 FIG. 11 is a rear perspective exploded view of the cooling container including an outer container and two inner containers.

**1 Claim, 10 Drawing Sheets**

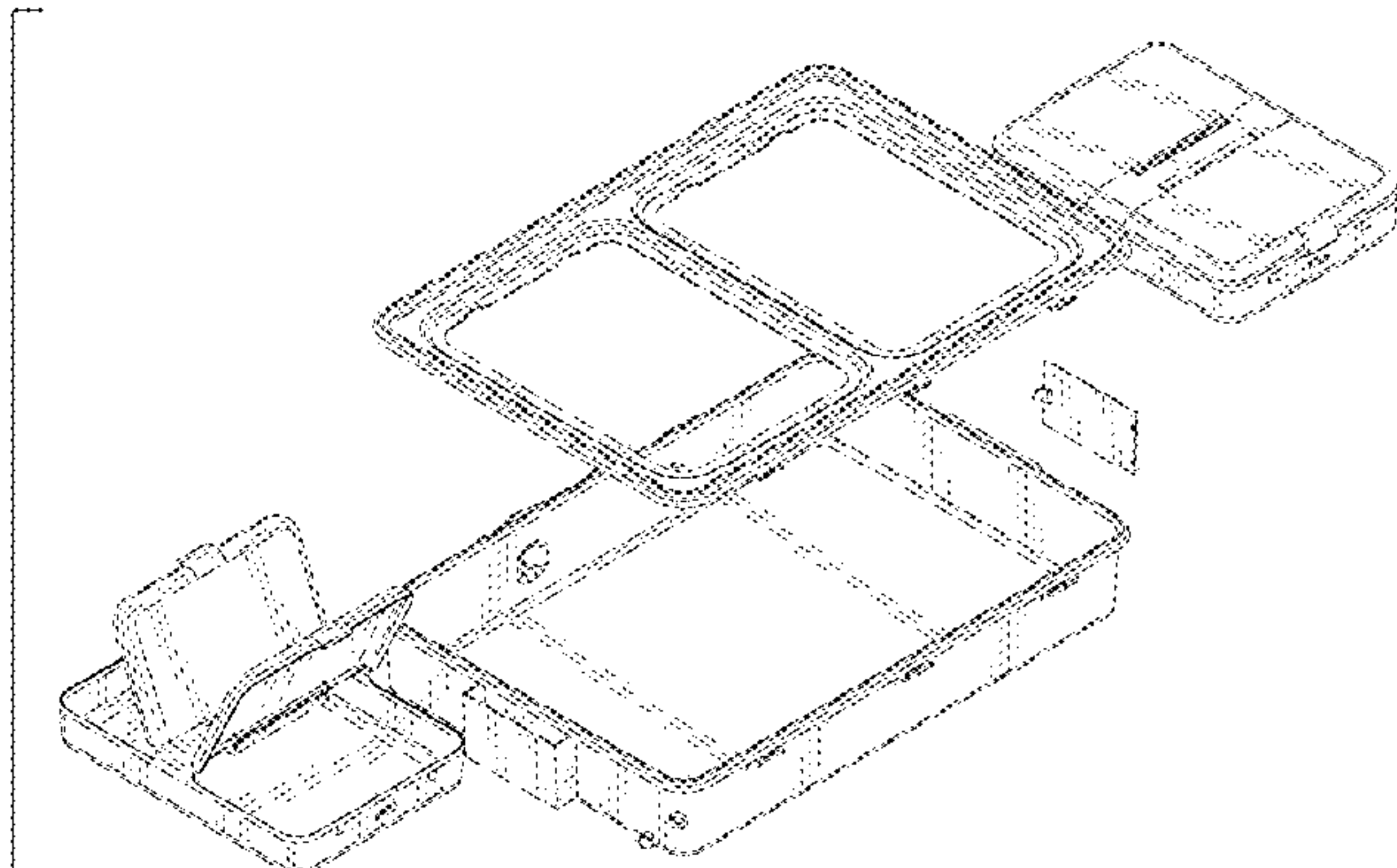
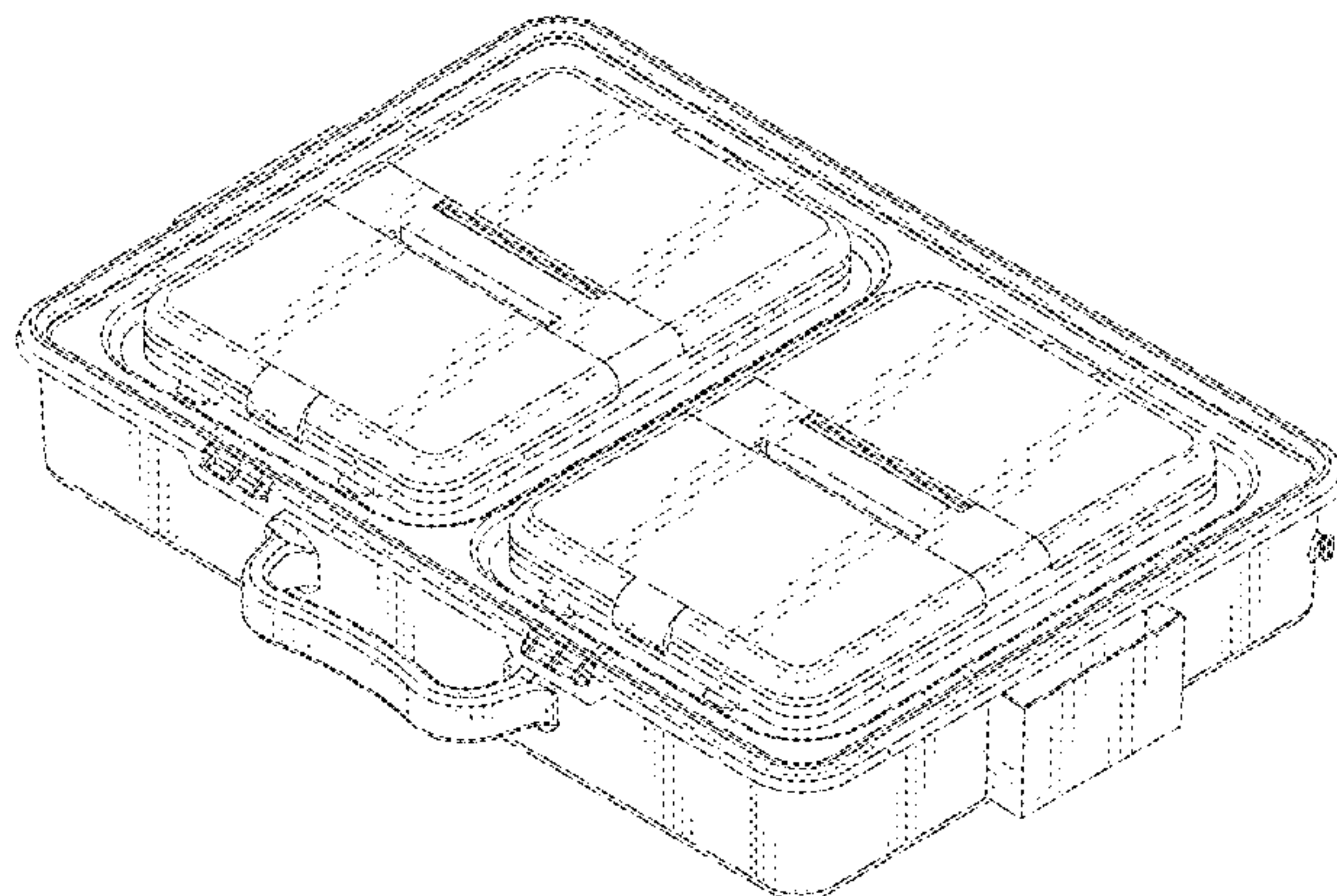

(56)

**References Cited**

U.S. PATENT DOCUMENTS

D696,910 S *	1/2014	Franczyk .....	D7/629
D698,206 S *	1/2014	Molayem .....	D7/629
D760,035 S *	6/2016	Kim .....	D7/629
D763,706 S *	8/2016	Shum .....	D9/737
D764,237 S *	8/2016	Yen .....	D7/629
D880,957 S *	4/2020	Xu .....	D7/629
D891,879 S *	8/2020	Adams, Jr. ....	D7/629
2006/0201950 A1 *	9/2006	Liu .....	B65D 1/36
			220/526
2010/0224531 A1 *	9/2010	Claffy .....	B65D 81/3823
			206/561
2020/0262637 A1 *	8/2020	Tattam .....	B65D 5/12

\* cited by examiner



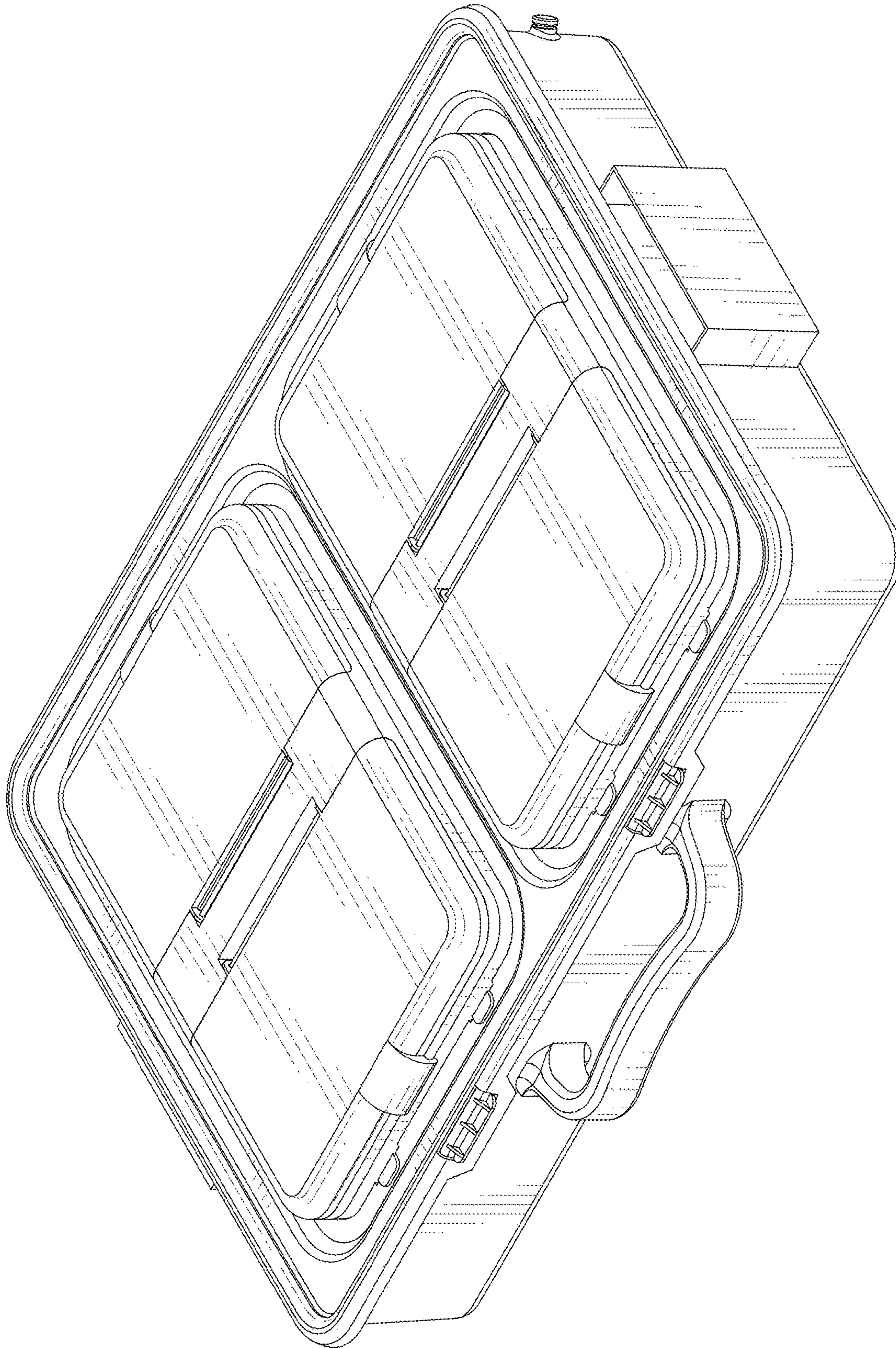

FIG. 1

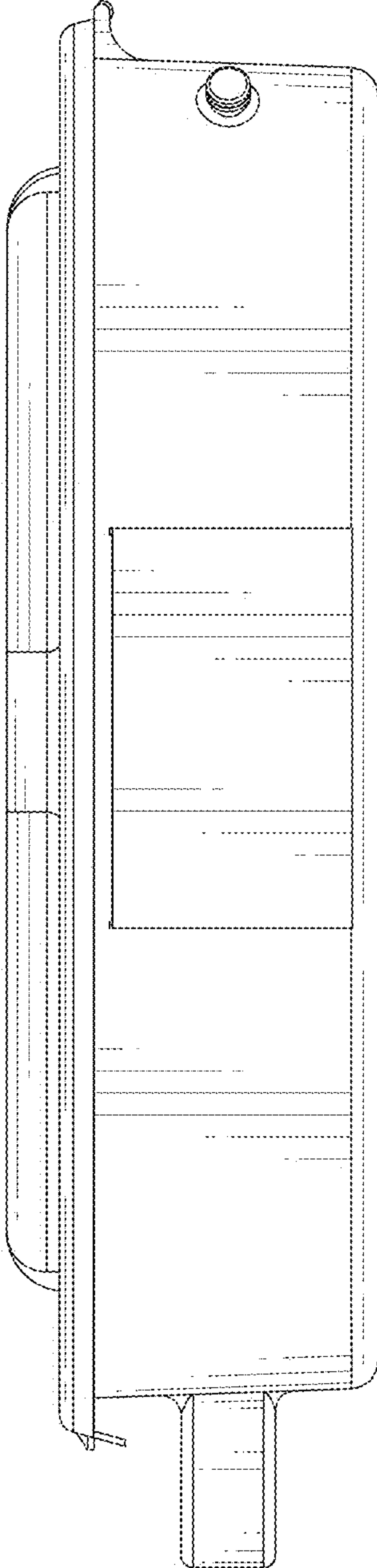

FIG. 2

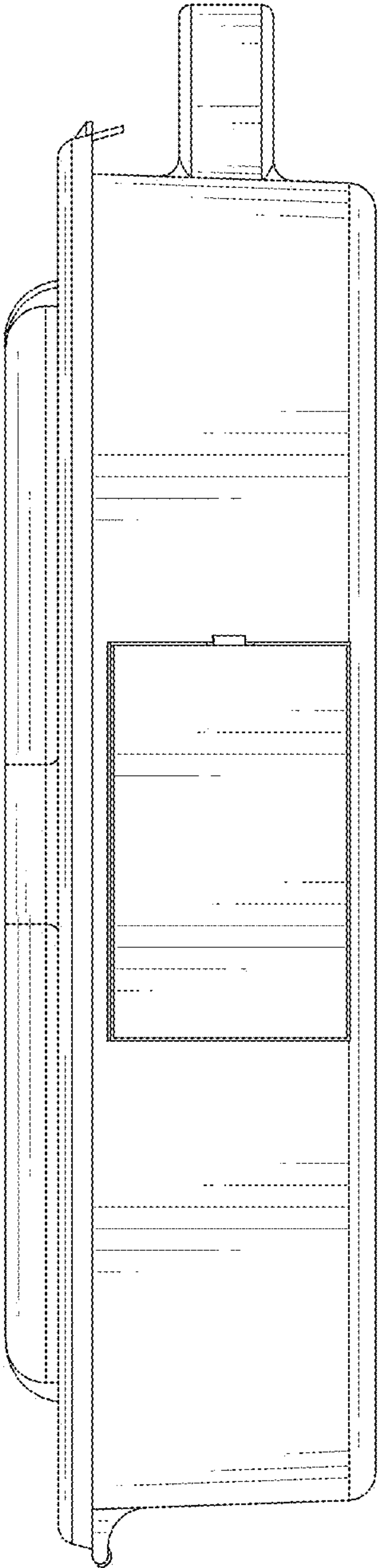

FIG.3

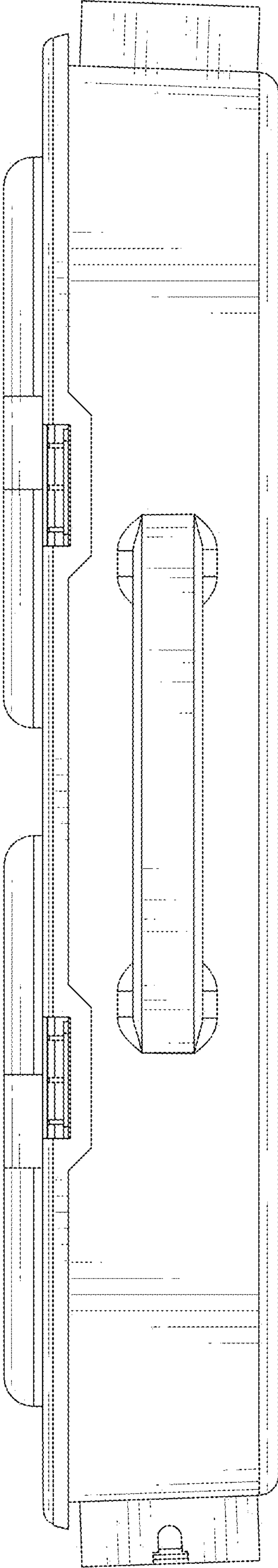

FIG. 4



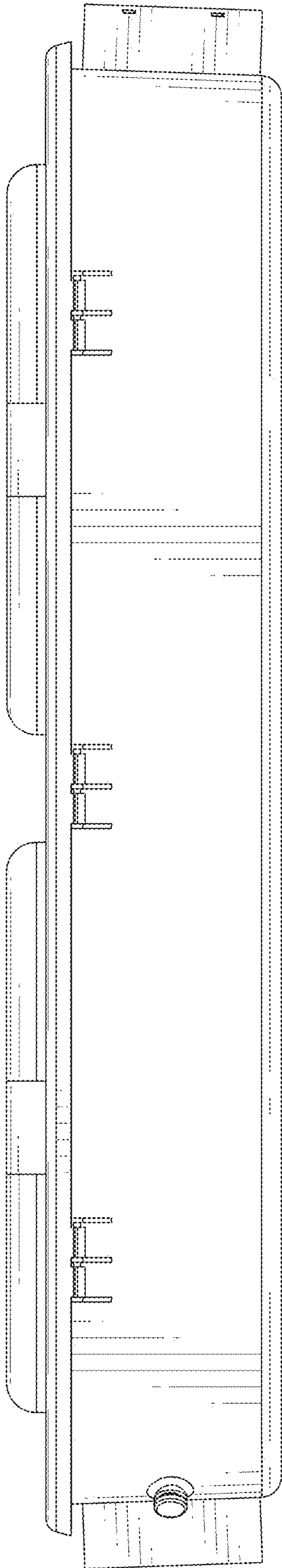

FIG. 5

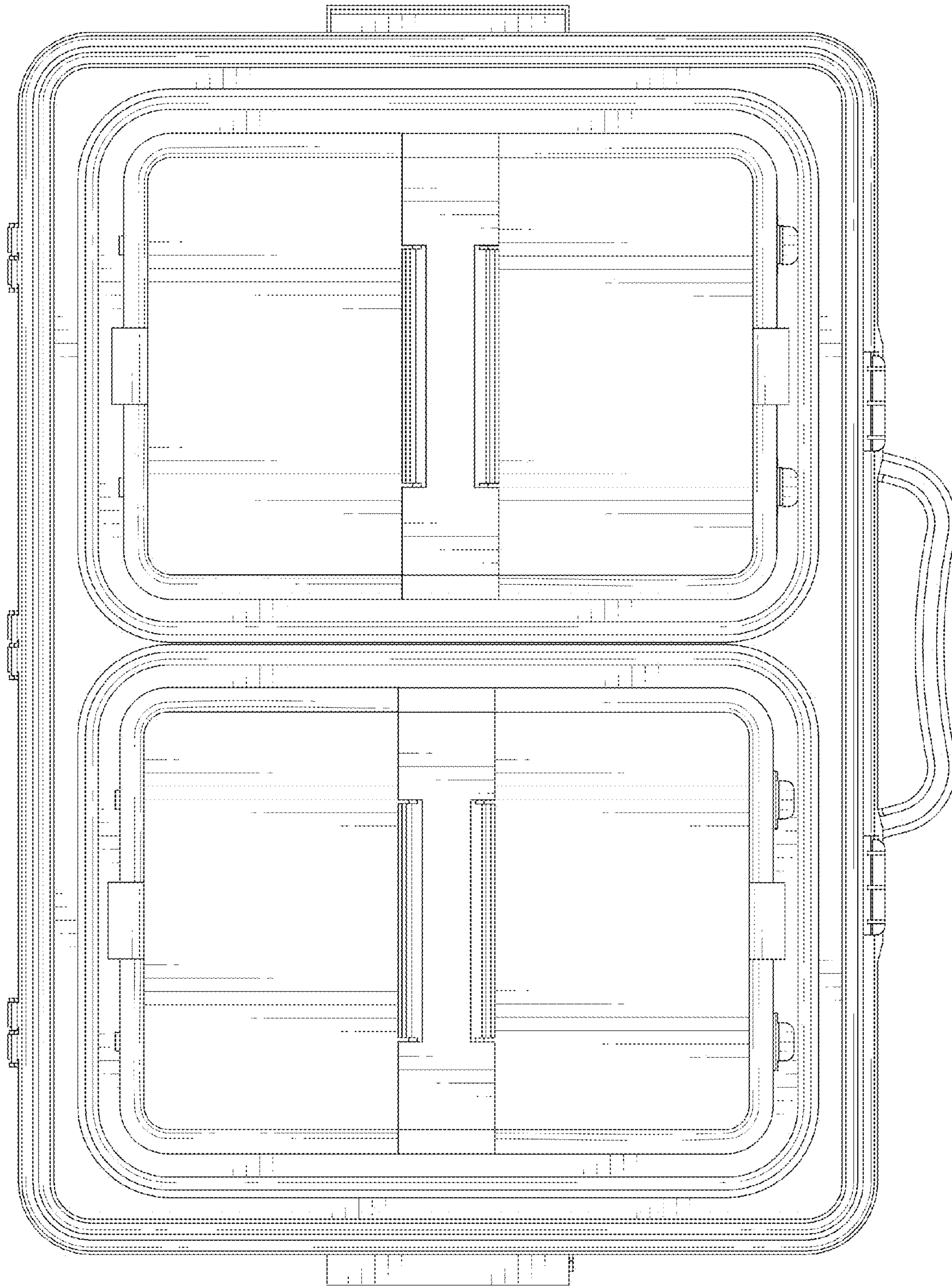

FIG. 6



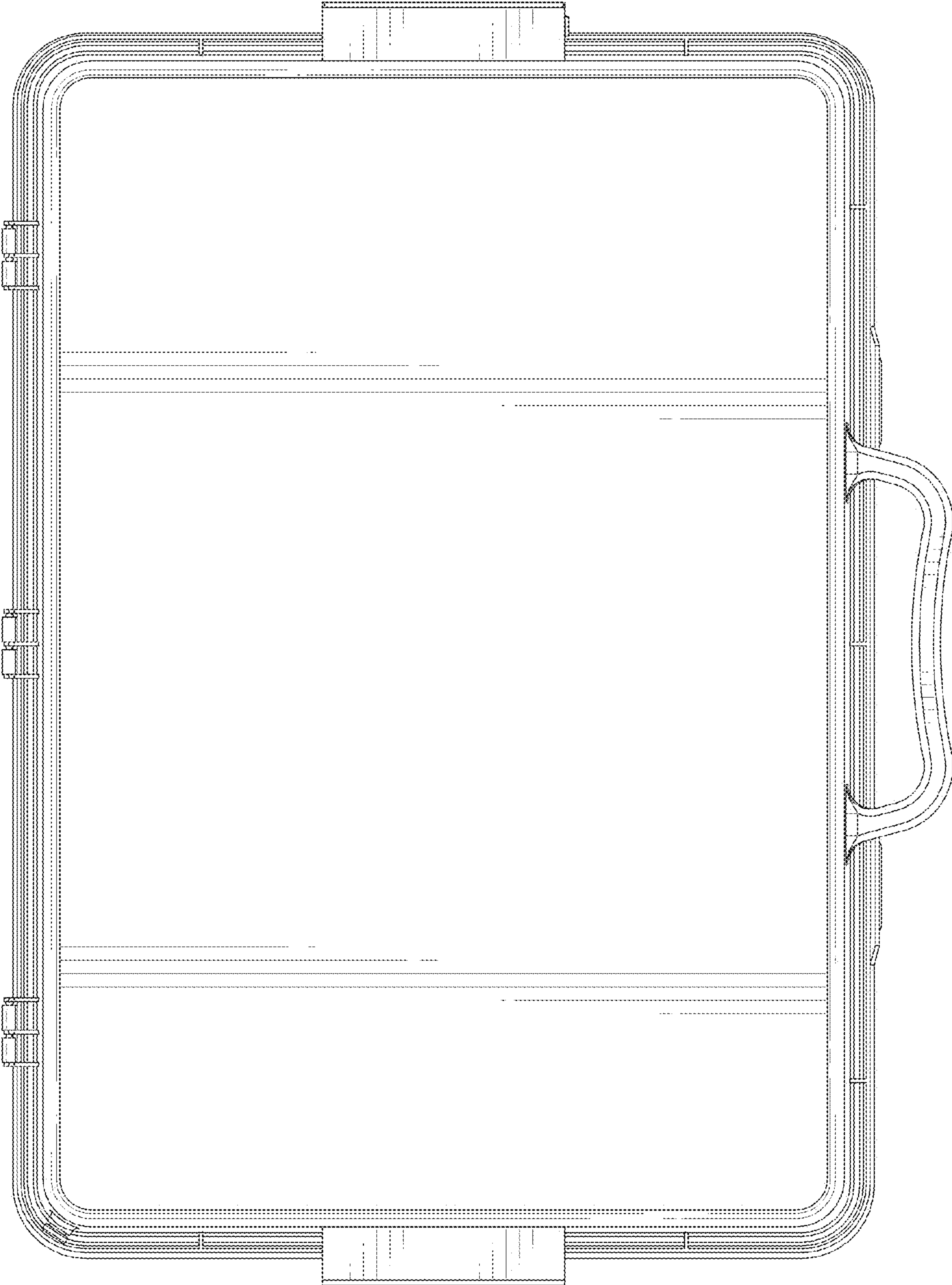

FIG. 7

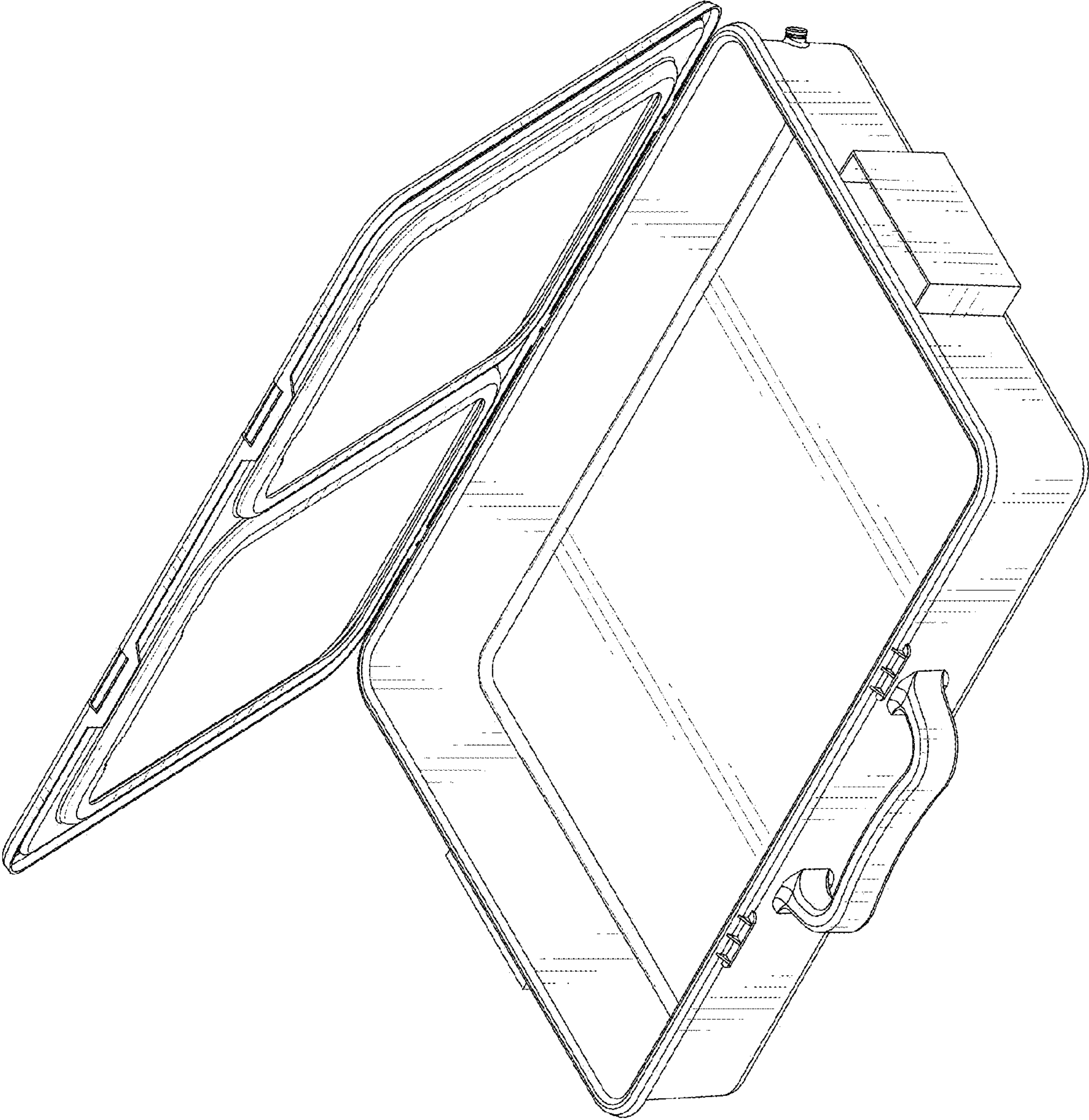

FIG. 8

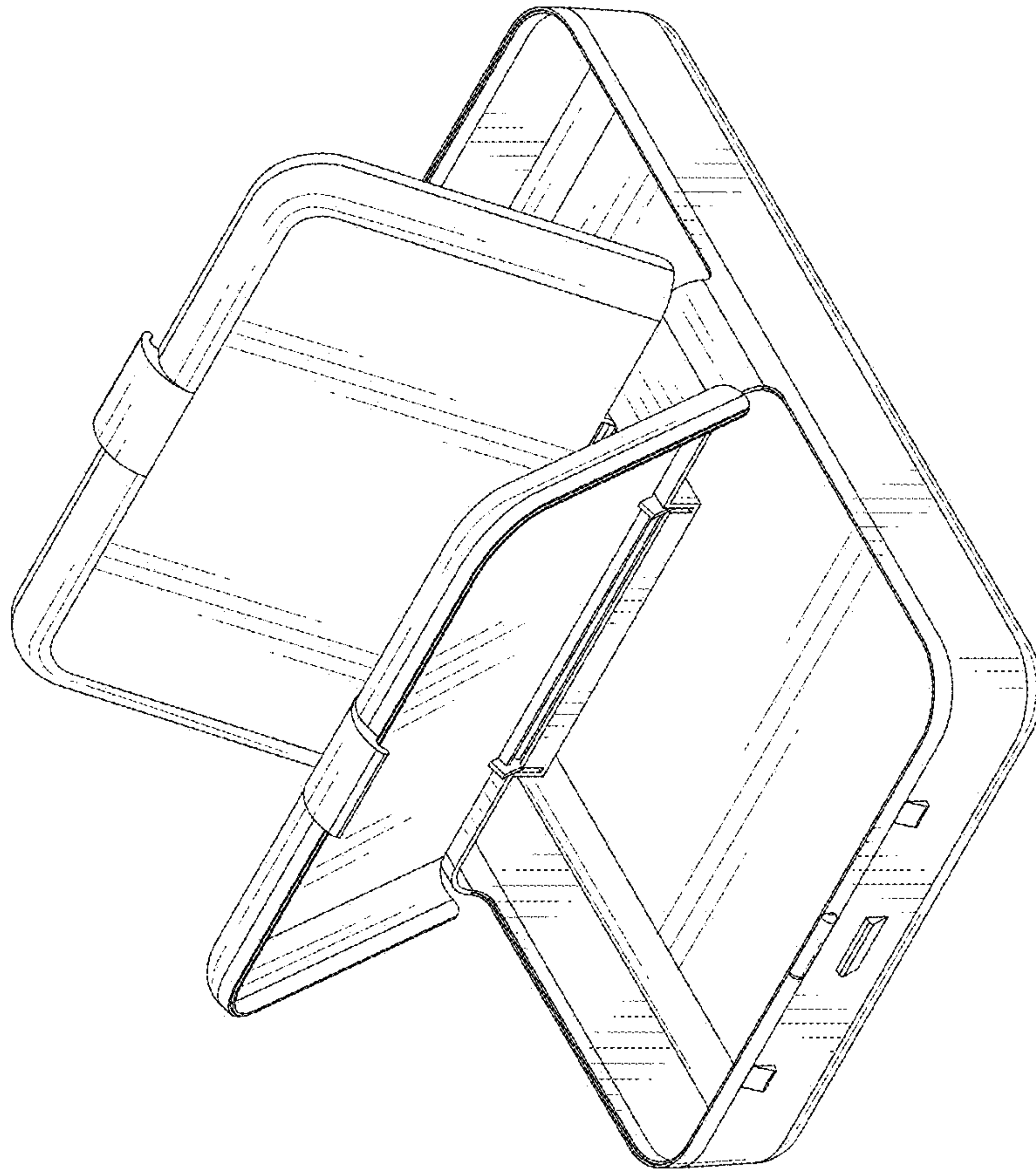

FIG. 10

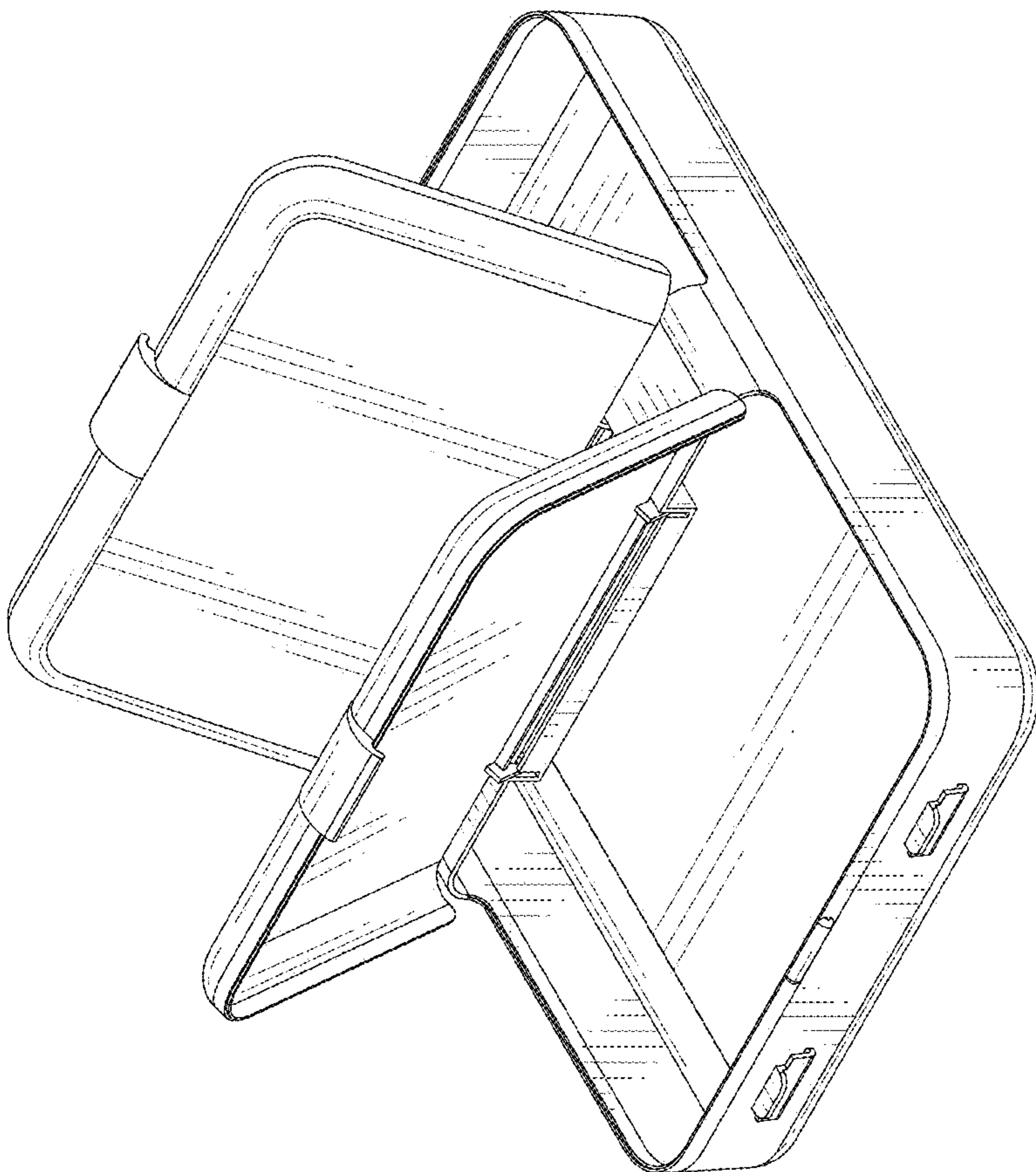

FIG. 9



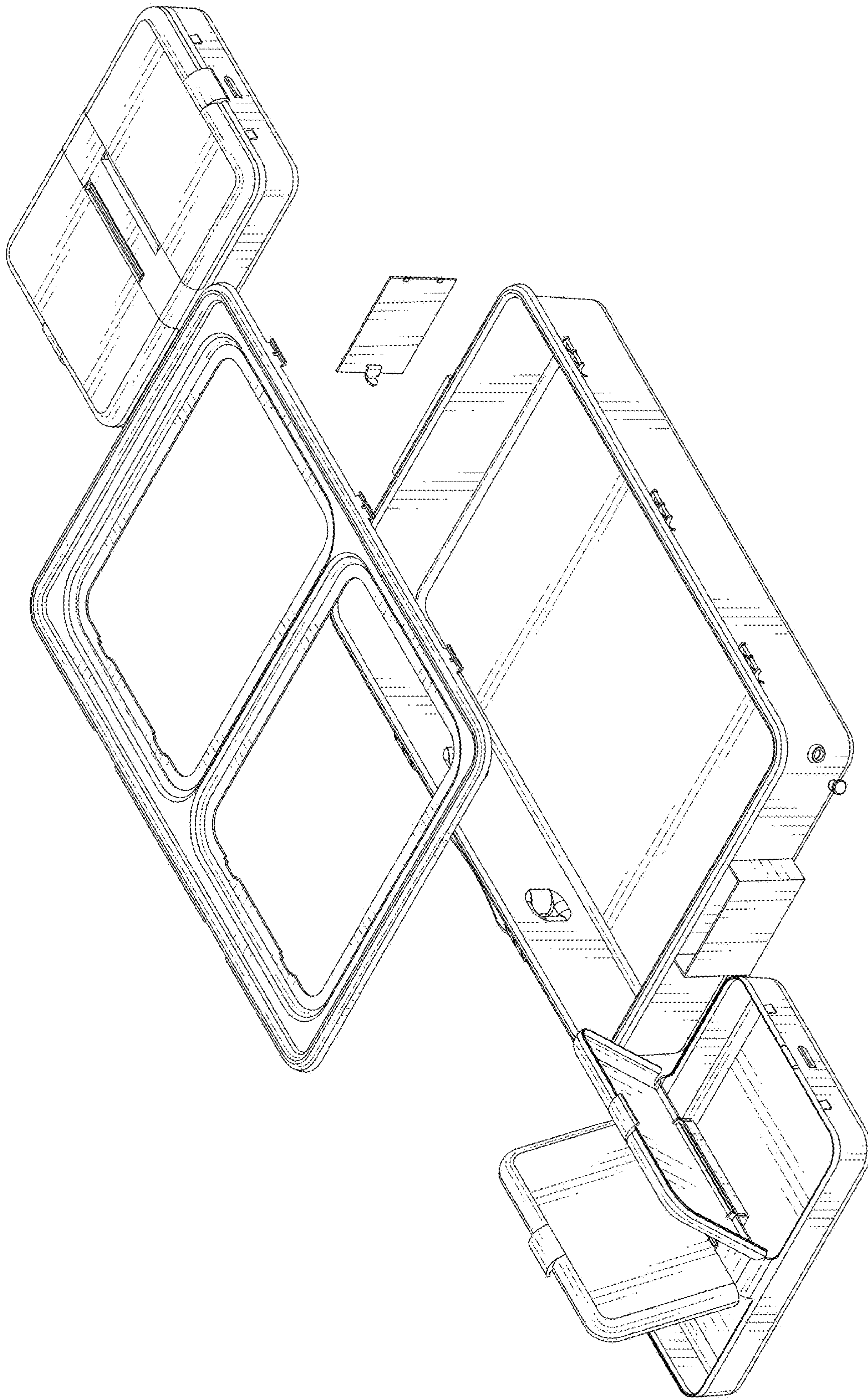

FIG. 11