



US00D911613S

(12) **United States Design Patent** (10) **Patent No.:** **US D911,613 S**  
**Jiang** (45) **Date of Patent:** **\*\* Feb. 23, 2021**

(54) **ELECTRIC HAIR CLIPPER**  
(71) Applicant: **NINGBO ICLIPPER ELECTRIC APPLIANCE CO., LTD.**, Ningbo (CN)  
(72) Inventor: **Qi Jiang**, Ningbo (CN)  
(\*\*) Term: **15 Years**  
(21) Appl. No.: **29/707,524**  
(22) Filed: **Sep. 29, 2019**  
(51) **LOC (13) Cl.** ..... **28-03**  
(52) **U.S. Cl.**  
USPC ..... **D28/53**  
(58) **Field of Classification Search**  
USPC ..... D28/49-54  
CPC ..... B26B 19/00-08; B26B 19/10-12; B26B 19/20-24; B26B 19/26-265; B26B 19/38-3826; B26B 19/3873-3893; B26B 19/42  
See application file for complete search history.

D790,133 S \* 6/2017 Aulwes ..... D28/54  
D815,355 S \* 4/2018 Fleming ..... D28/53  
D821,652 S \* 6/2018 Skuhra ..... D28/53  
10,059,013 B2 \* 8/2018 Skuhra ..... B26B 19/3853  
D844,245 S \* 3/2019 Wu ..... D28/53  
D846,192 S \* 4/2019 Wu ..... D28/53  
D847,432 S \* 4/2019 Aulwes ..... D28/54  
10,518,427 B2 \* 12/2019 Skuhra ..... B26B 19/3853  
2003/0051346 A1 \* 3/2003 McCambridge .... B26B 19/3846  
30/122  
2013/0200823 A1 \* 8/2013 Chan ..... H02K 33/16  
318/3

\* cited by examiner

*Primary Examiner* — Jennifer Rivard  
(74) *Attorney, Agent, or Firm* — W&K IP

(57) **CLAIM**

The ornamental design for an electric hair clipper, as shown and described.

**DESCRIPTION**

FIG. 1 is a front elevation view of an electric hair clipper showing my design;  
FIG. 2 is a back elevation view thereof;  
FIG. 3 is a left side view thereof;  
FIG. 4 is a right side view thereof;  
FIG. 5 is a top plan view thereof;  
FIG. 6 is a bottom plan view thereof;  
FIG. 7 is a perspective view thereof; and,  
FIG. 8 is another perspective view thereof.  
The broken lines illustrate a portion of the electric hair clipper that forms no part of the claimed design.

**1 Claim, 7 Drawing Sheets**

(56) **References Cited**  
U.S. PATENT DOCUMENTS  
D435,936 S \* 1/2001 Long ..... D28/54  
D497,452 S \* 10/2004 Nielsen ..... D28/53  
D500,392 S \* 12/2004 Buck, Jr. .... D28/54  
D534,689 S \* 1/2007 Gross ..... D28/53  
D571,504 S \* 6/2008 Long ..... D28/54  
D597,254 S \* 7/2009 Eddinger ..... D28/54  
D715,489 S \* 10/2014 Aulwes ..... D28/54  
D715,490 S \* 10/2014 Aulwes ..... D28/54  
9,038,276 B2 \* 5/2015 Arndt ..... B26B 19/06  
30/208  
D758,665 S \* 6/2016 Skuhra ..... D28/54

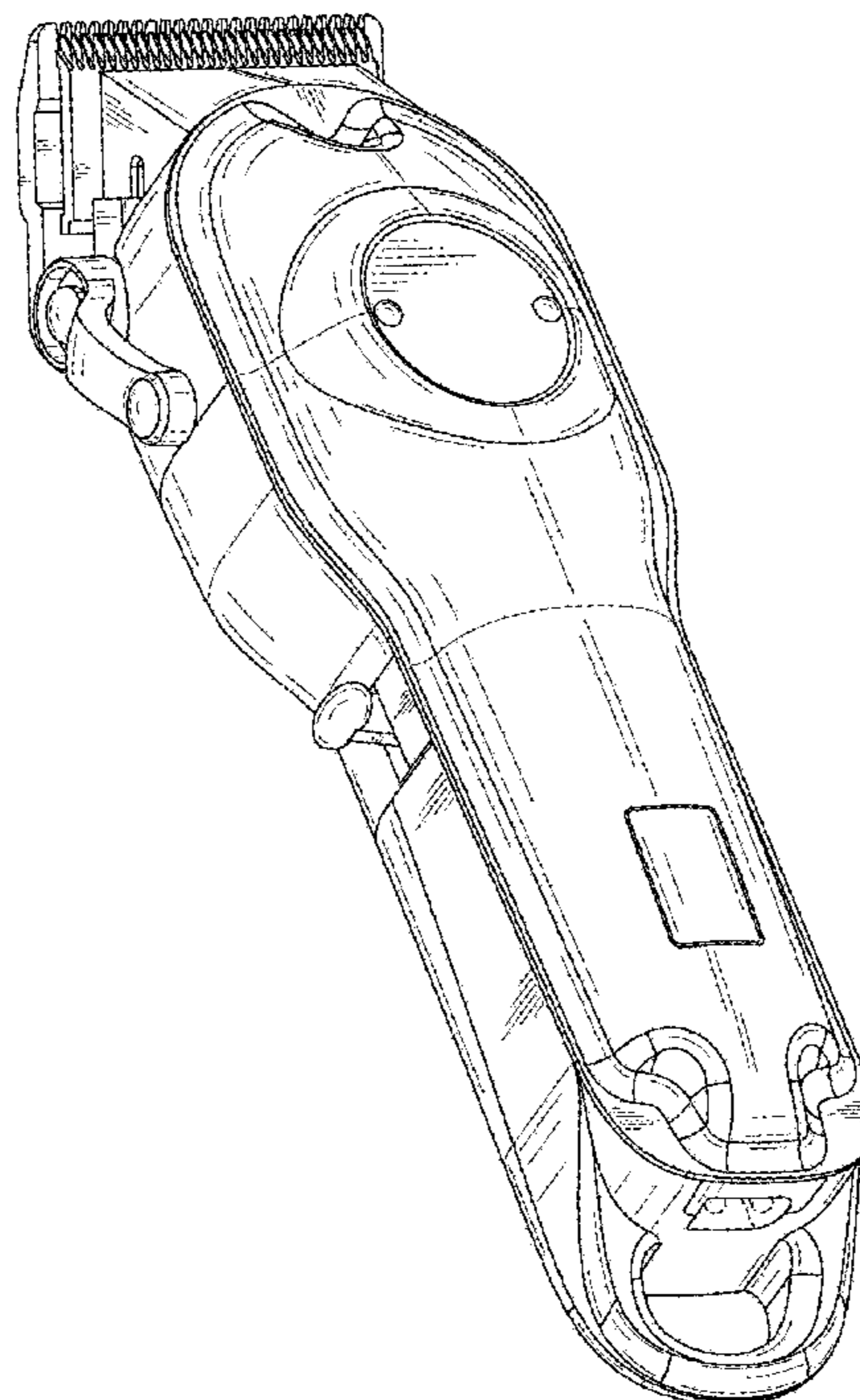

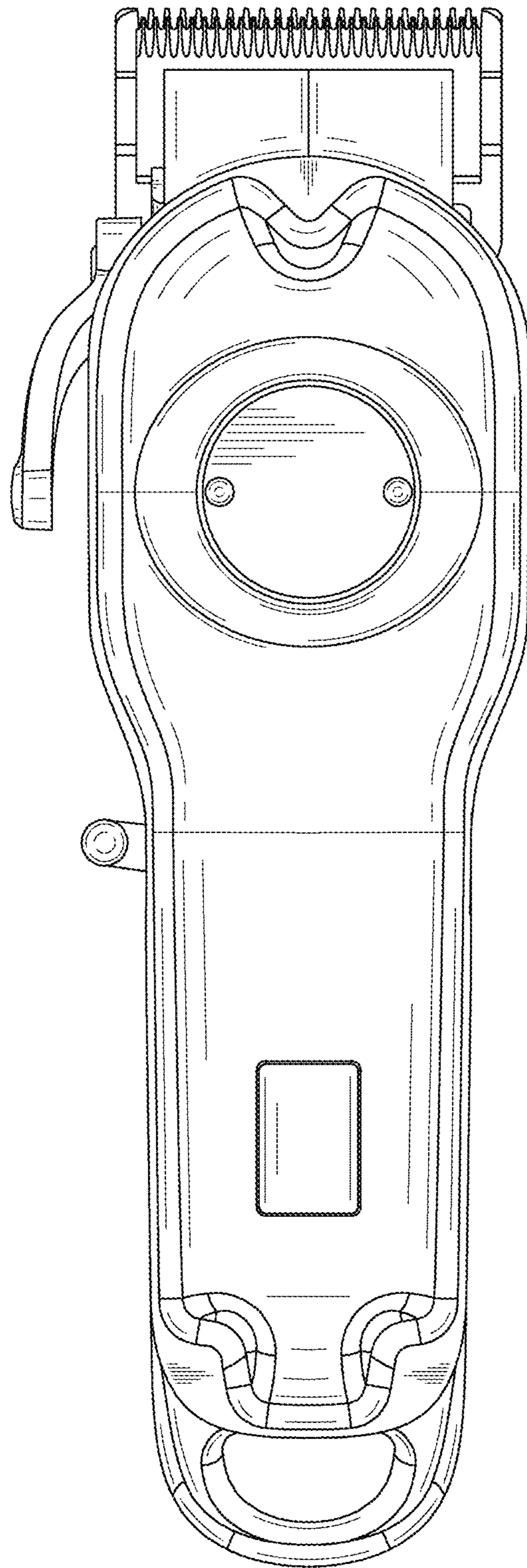

FIG.1

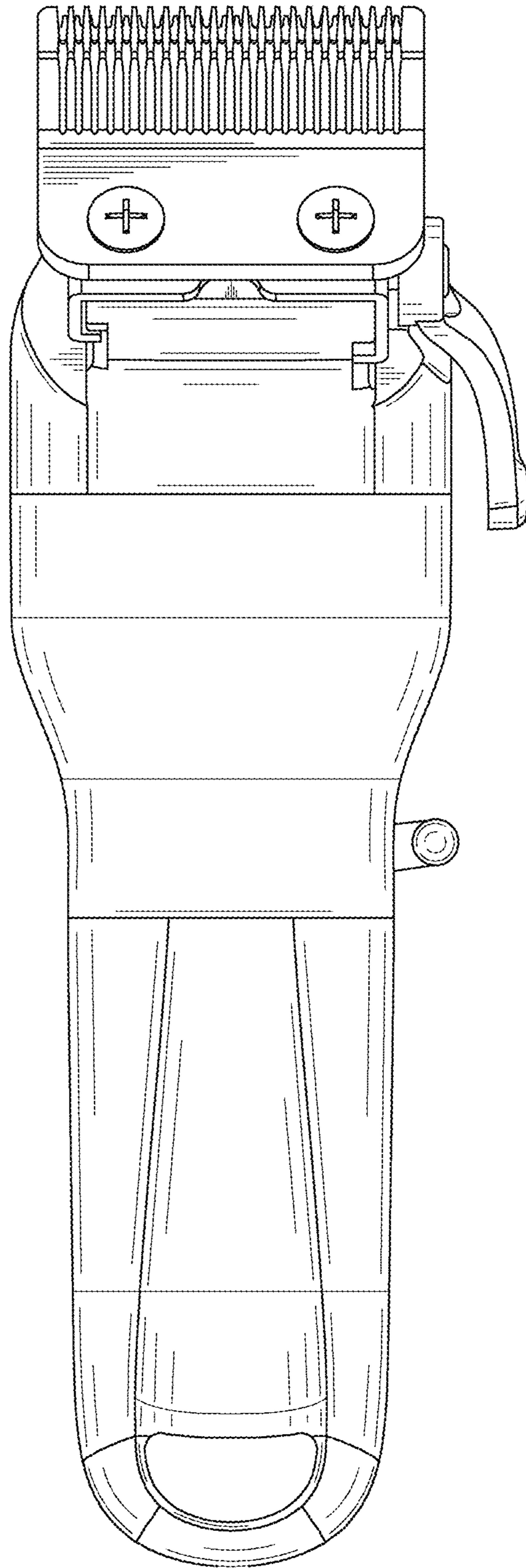

FIG.2

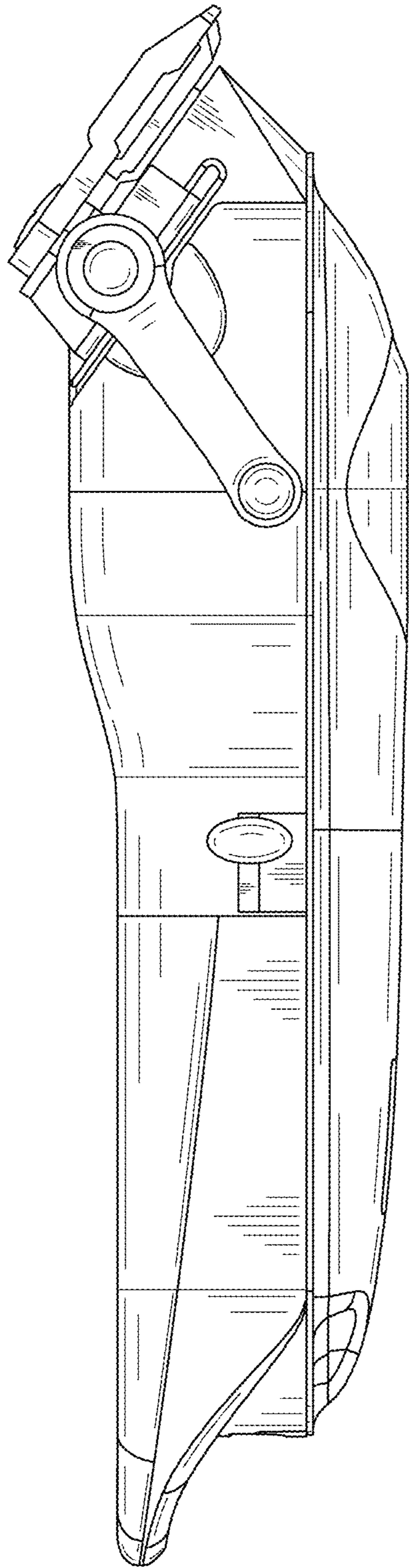

FIG.3

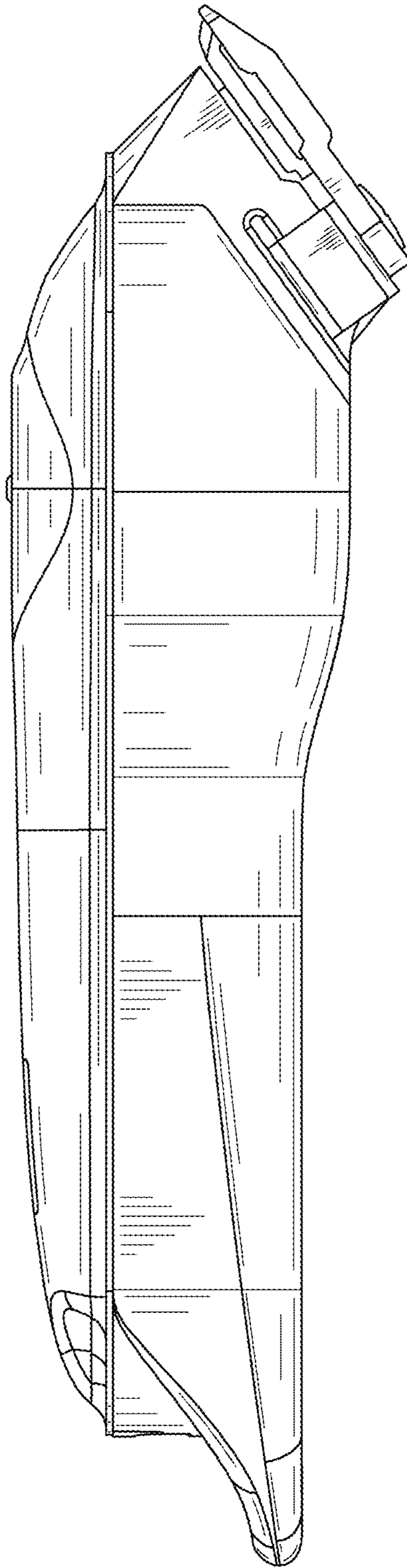

FIG.4

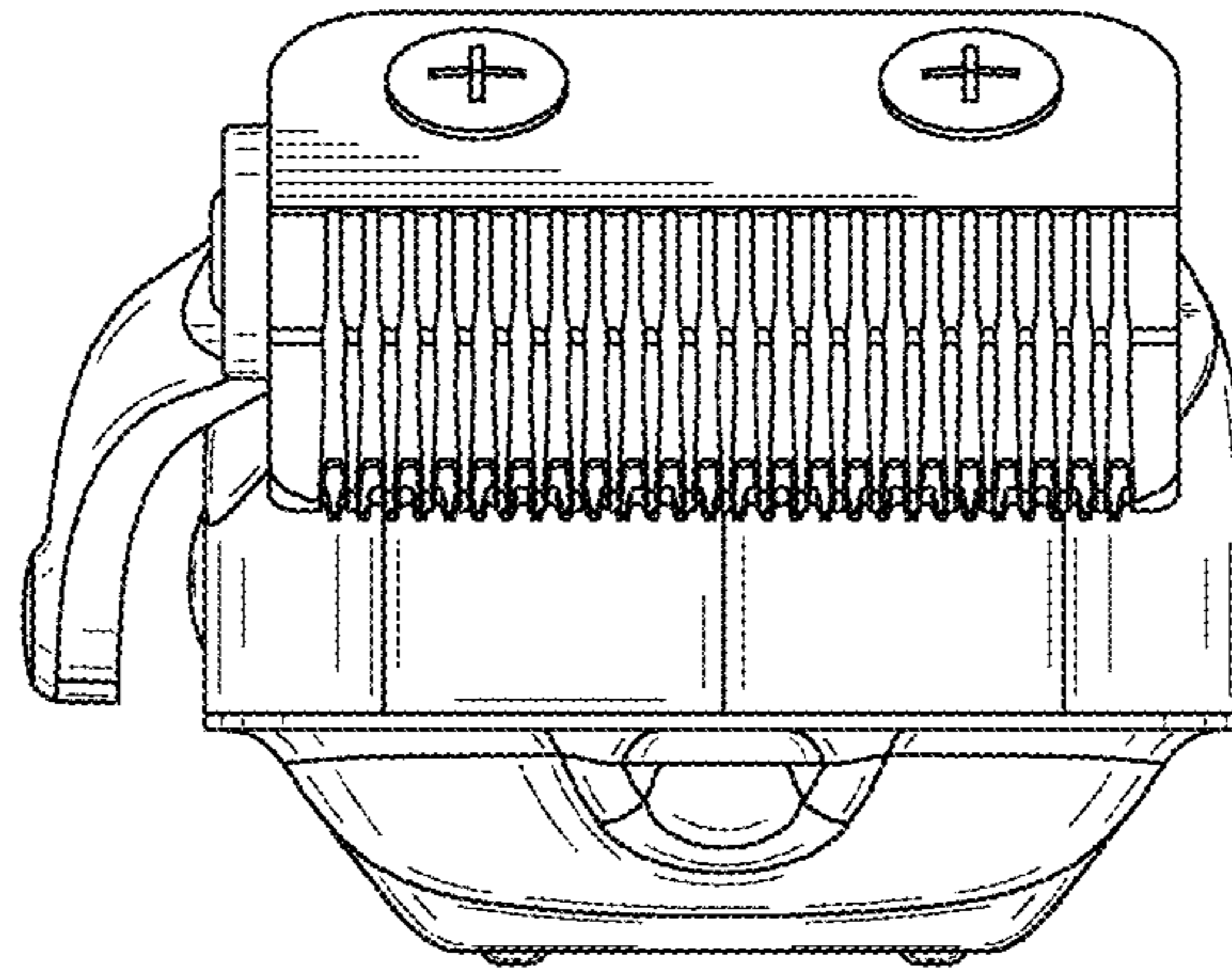

FIG. 5

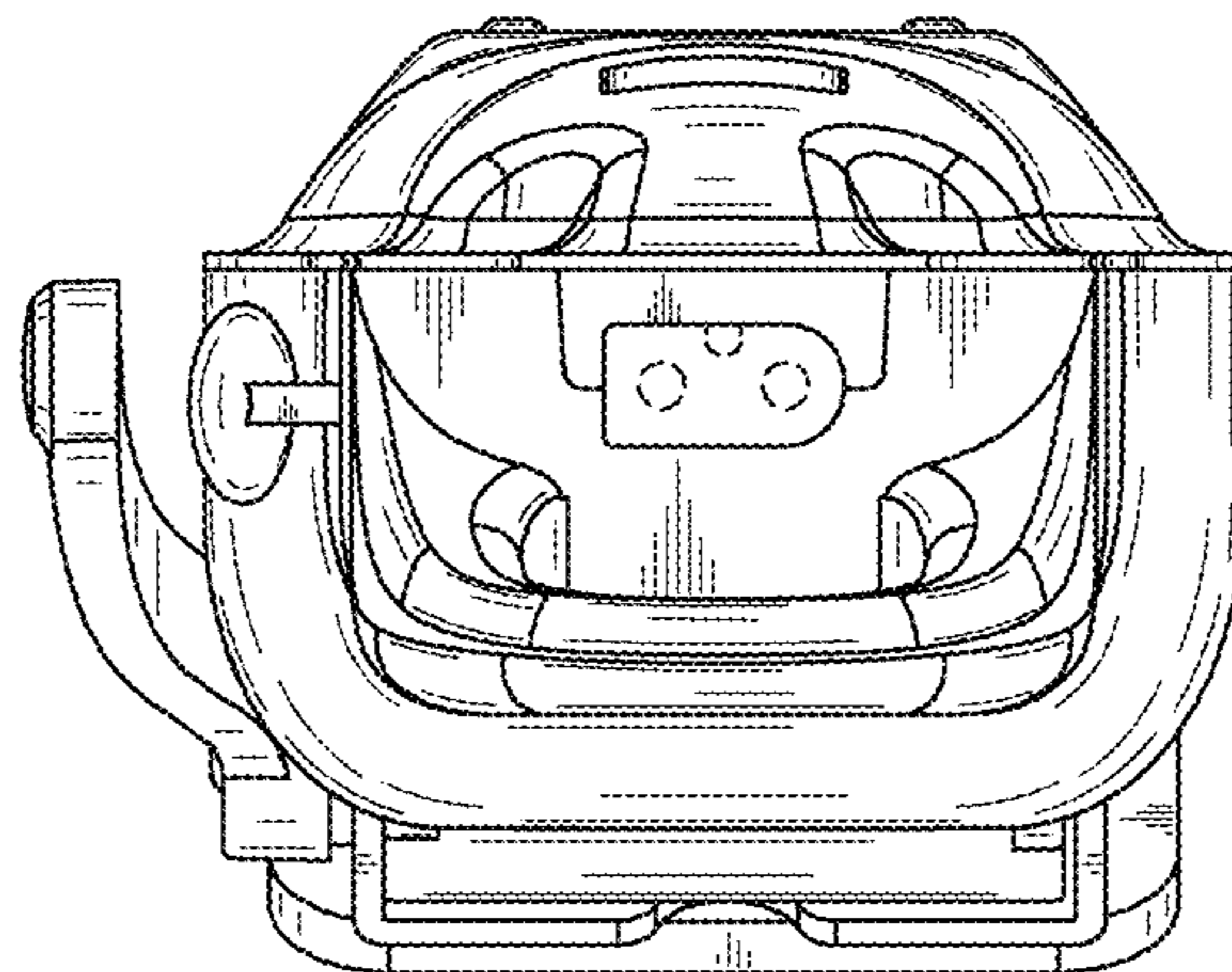

FIG. 6

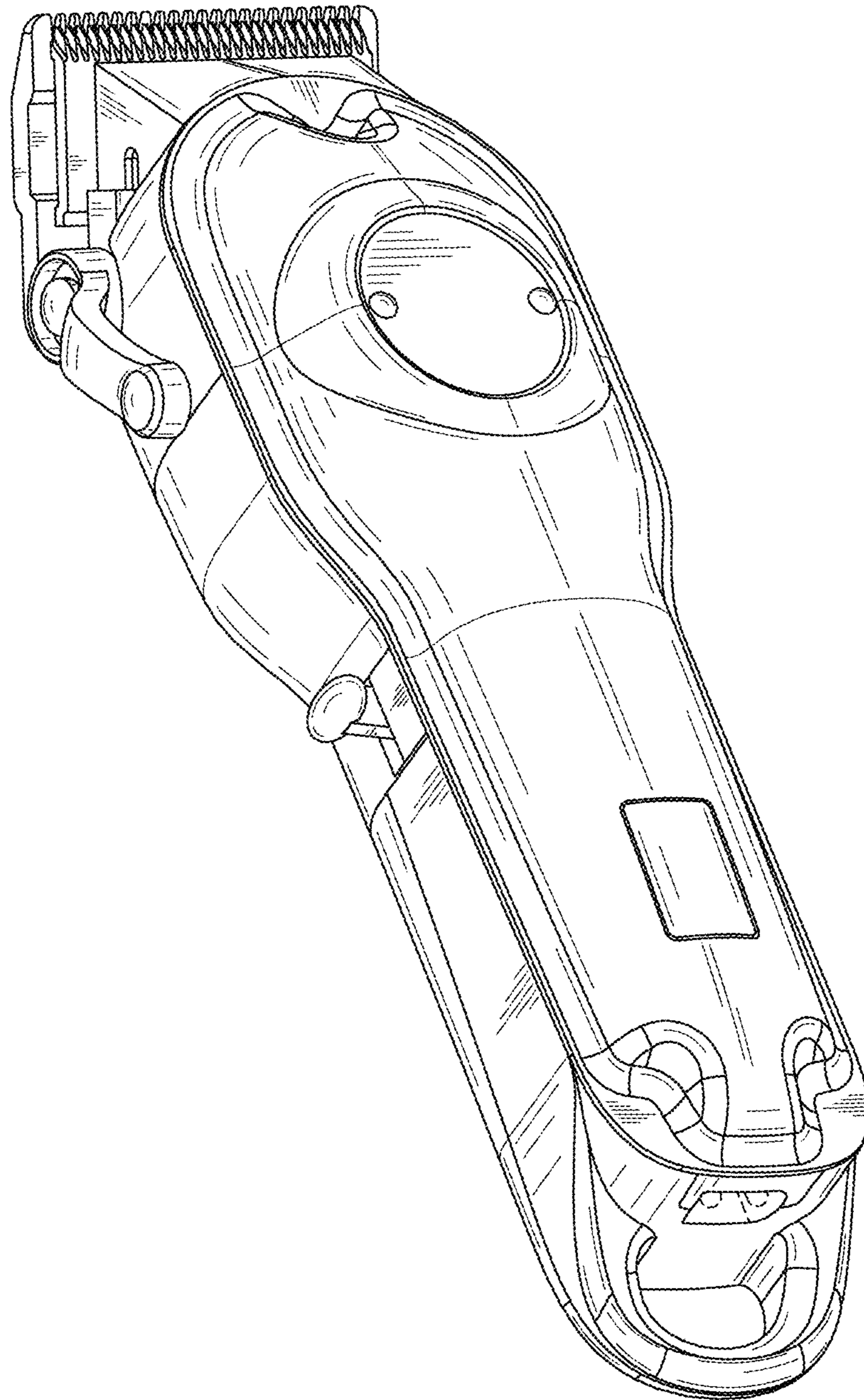

FIG. 7

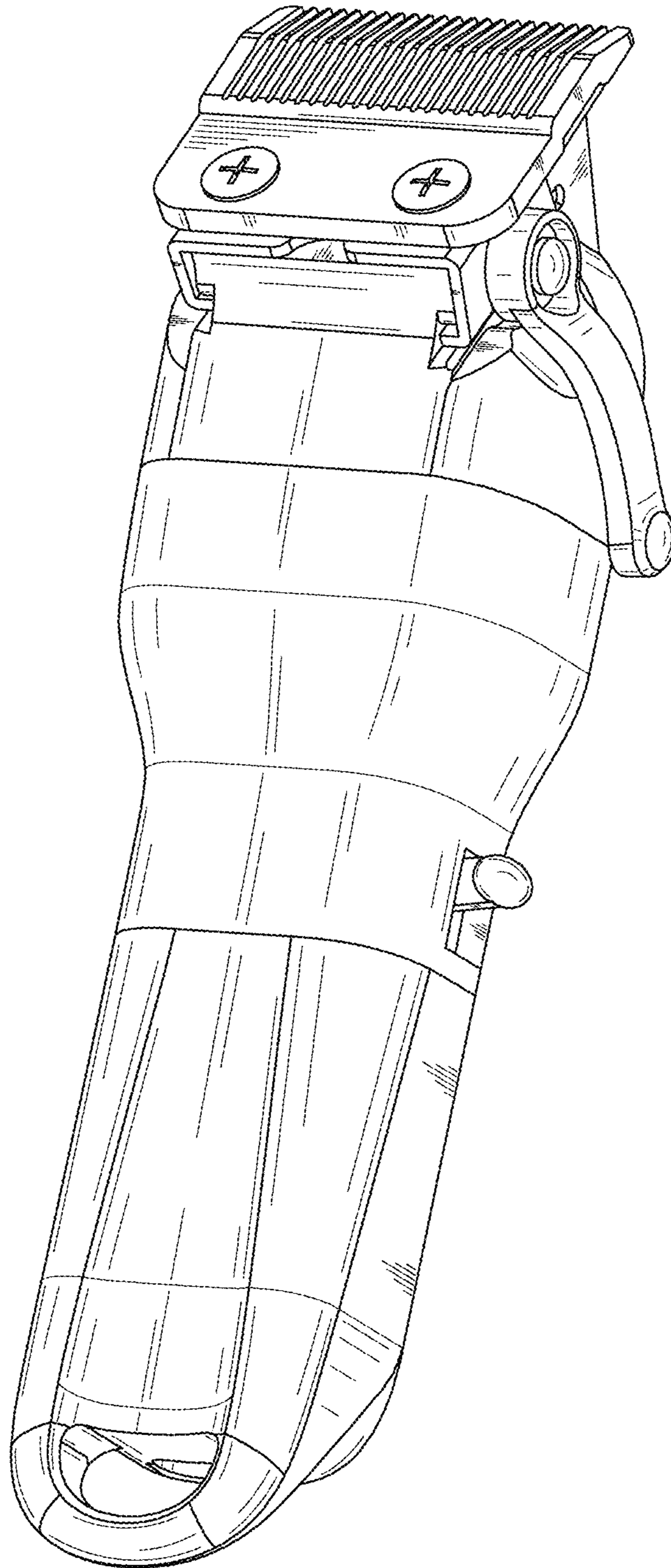

FIG.8