



US00D911222S

(12) **United States Design Patent**
Jung et al.

(10) **Patent No.:** **US D911,222 S**

(45) **Date of Patent:** **** Feb. 23, 2021**

(54) **VEHICLE AND/OR REPLICA**
(71) Applicant: **DIVERGENT TECHNOLOGIES, INC.**, Los Angeles, CA (US)
(72) Inventors: **Hyuk Woo Jung**, Torrance, CA (US); **David Charles O’Connell**, Huntington Beach, CA (US); **Cheng Wei Yu**, Pasadena, CA (US); **Kevin Robert Czinger**, Santa Monica, CA (US); **Broc William Tenhouten**, Rancho Palos Verdes, CA (US)

D797,606 S * 9/2017 Oh D12/92
D808,302 S * 1/2018 Oh D12/92
D817,815 S * 5/2018 Hubers D12/91
D821,923 S * 7/2018 Lee D12/92
D840,268 S * 2/2019 Beaven D12/91
D873,177 S * 1/2020 Xu D12/91
D876,279 S * 2/2020 Mayer D12/91
D877,658 S * 3/2020 Burki D12/91
D885,257 S * 5/2020 Churchill D12/91
D890,031 S * 7/2020 Metros D12/91
D896,126 S * 9/2020 Platto D12/91

* cited by examiner

Primary Examiner — Melody N Brown

(74) *Attorney, Agent, or Firm* — Arent Fox LLP

(73) Assignee: **DIVERGENT TECHNOLOGIES, INC.**, Los Angeles, CA (US)

(**) Term: **15 Years**

(57) **CLAIM**

The ornamental design for a vehicle and/or replica, as shown and described.

(21) Appl. No.: **29/671,049**

DESCRIPTION

(22) Filed: **Nov. 21, 2018**

(51) **LOC (13) Cl.** **12-08**

(52) **U.S. Cl.**
USPC **D12/91**

(58) **Field of Classification Search**
USPC D12/86, 90–92, 88; D21/424, 433, 434, D21/533; 296/181.1–181.5, 183.1
CPC B62D 25/00; B62D 25/06; B62D 33/00; B62D 35/00
See application file for complete search history.

FIG. 1 is a left, front perspective view of a vehicle showing our new design;
FIG. 2 is a left, rear perspective view thereof;
FIG. 3 is a front elevational view thereof;
FIG. 4 is a rear elevational view thereof;
FIG. 5 is a right side elevational view thereof, the left side being a mirror image thereof; and,
FIG. 6 is a top plan view thereof.
The bottom of the vehicle and/or replica forms no part of the claimed design. The broken lines shown in the figures are included for the purpose of illustrating portions of the vehicle and/or replica and form no part of the claimed design.

(56) **References Cited**

U.S. PATENT DOCUMENTS

D547,239 S * 7/2007 Murakawa D12/92
D574,754 S * 8/2008 Miniati D12/92

1 Claim, 6 Drawing Sheets

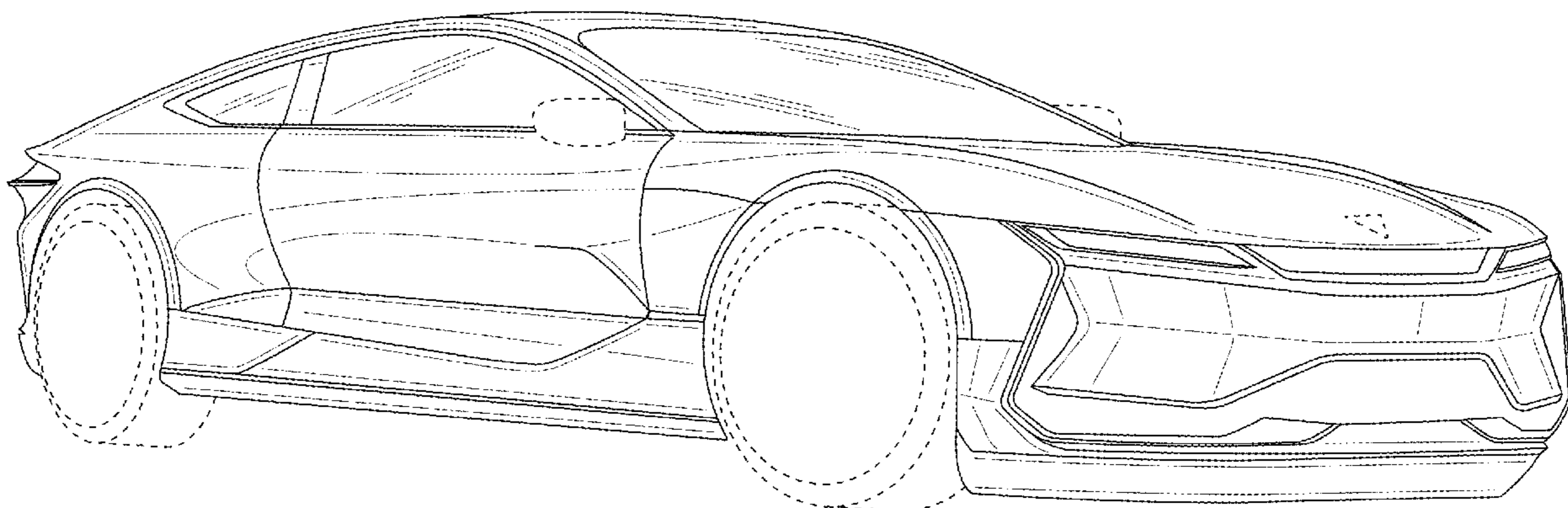

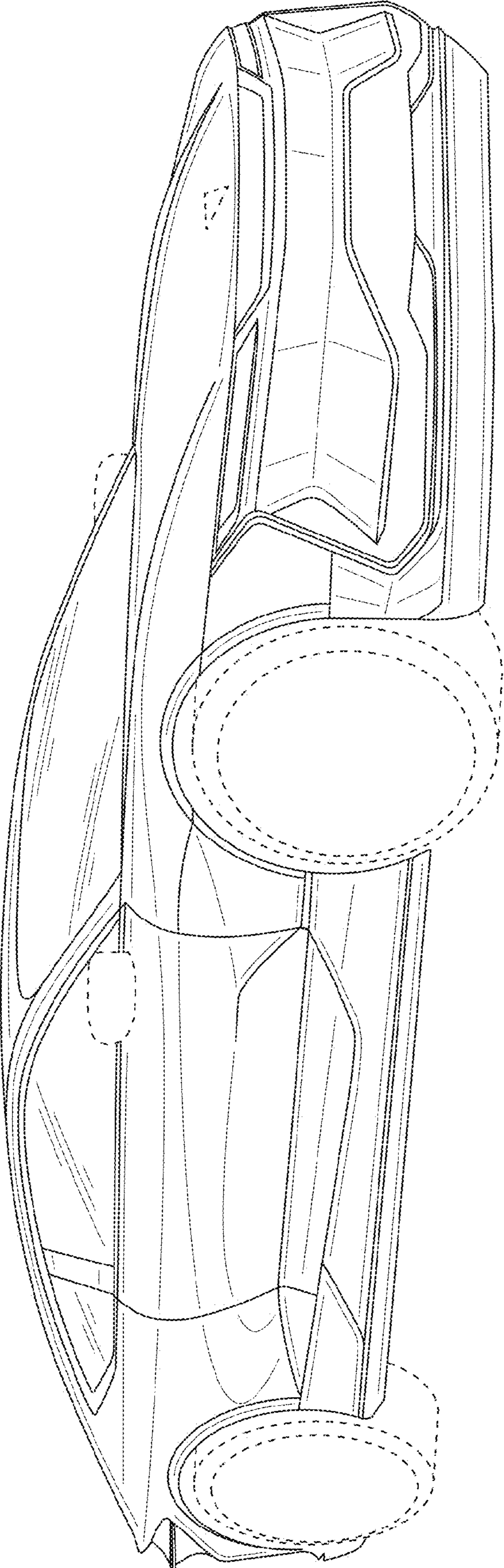

FIG. 1

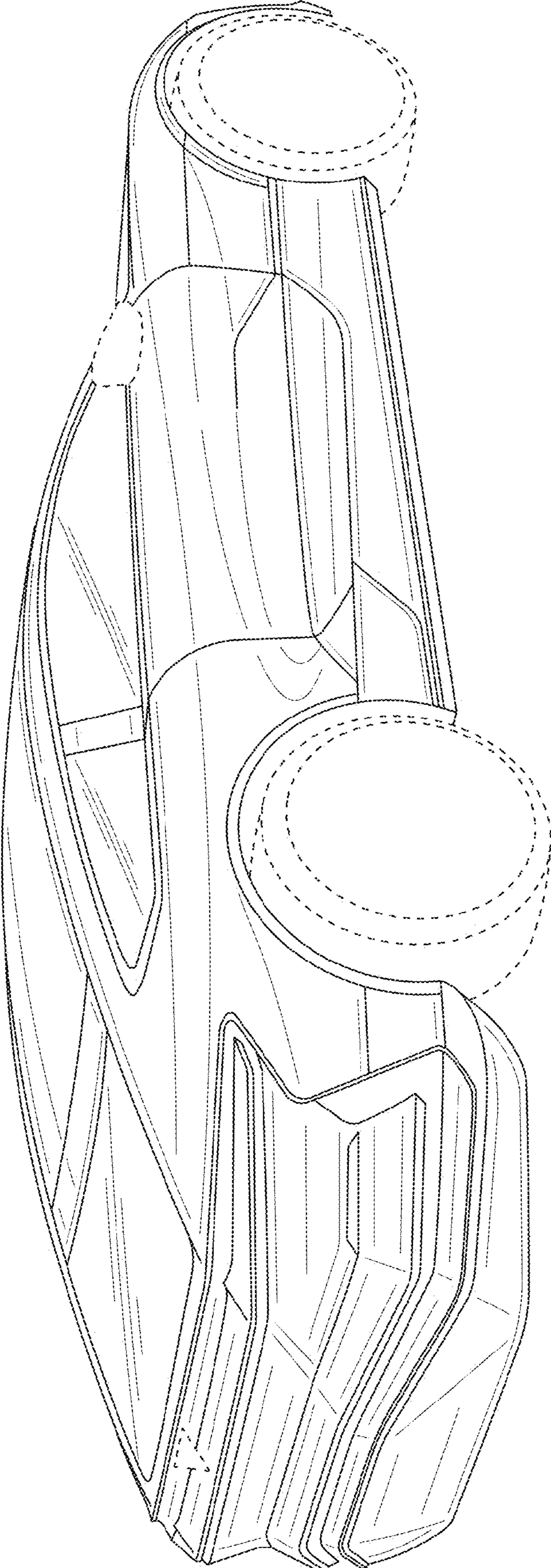

FIG. 2

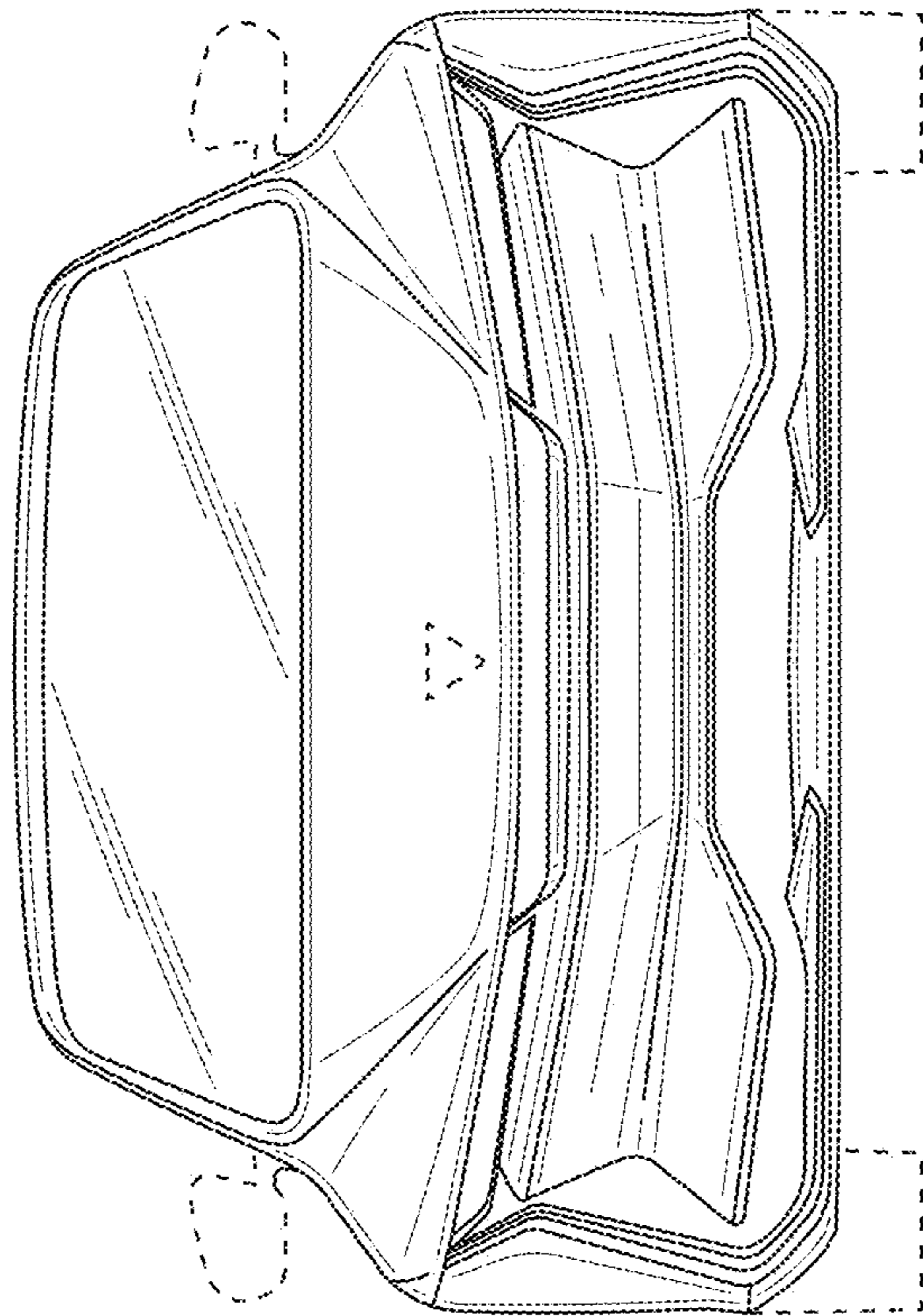

FIG. 3

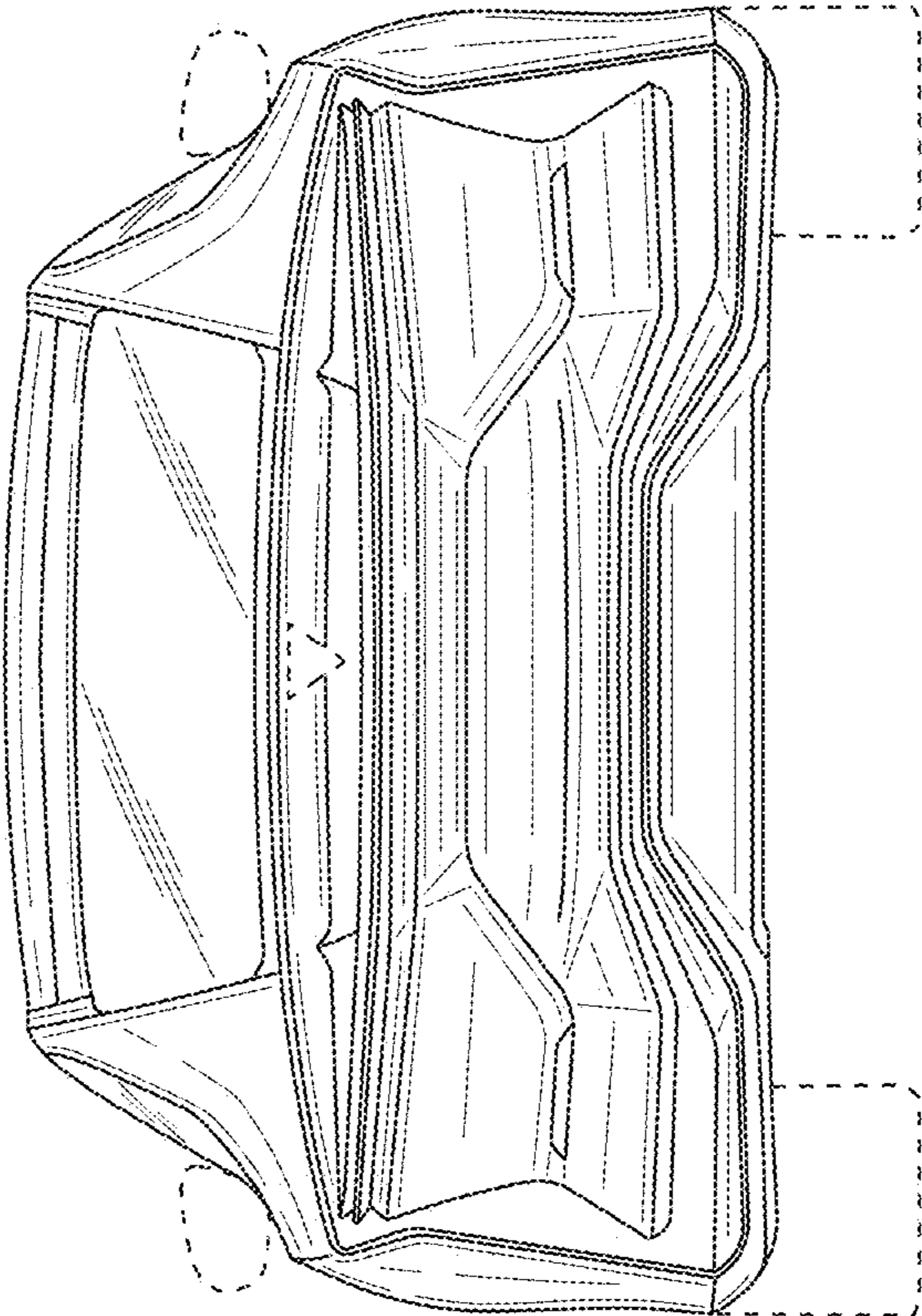

FIG. 4

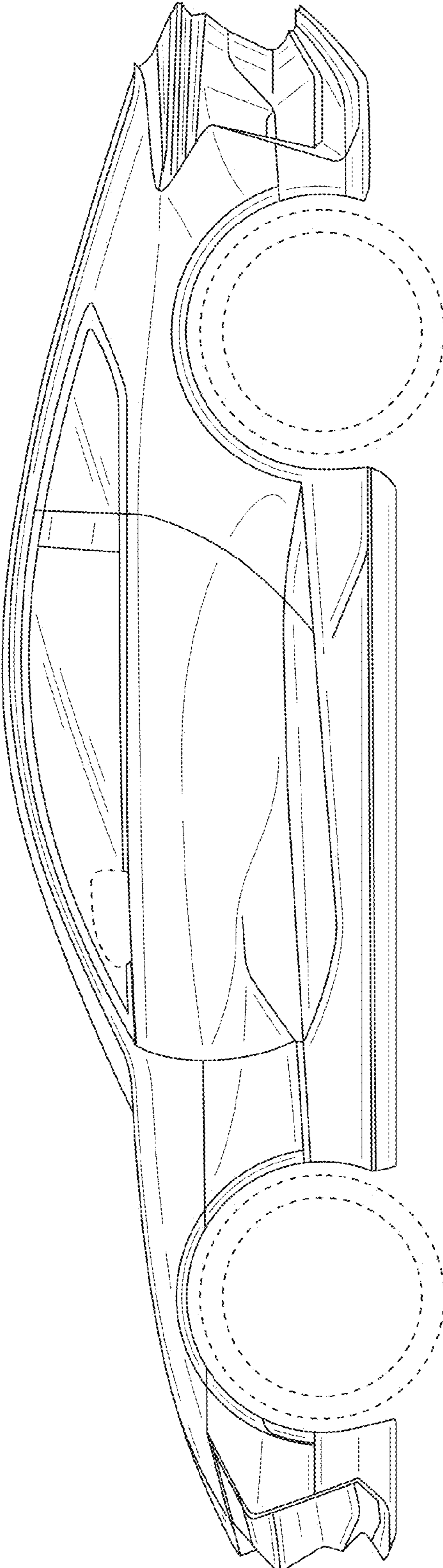

FIG. 5

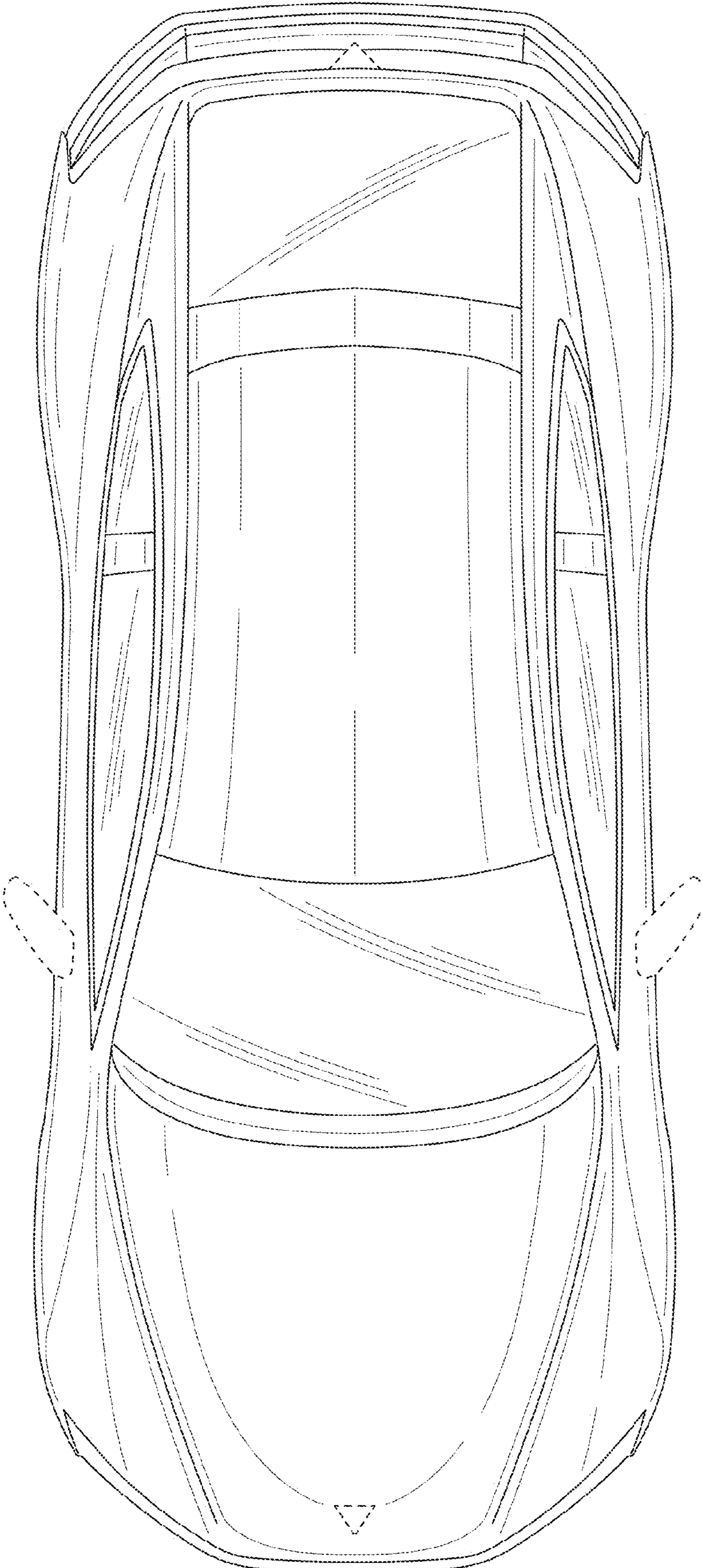

FIG. 6