



US00D911219S

(12) **United States Design Patent**  
**Simpson et al.**

(10) **Patent No.: US D911,219 S**

(45) **Date of Patent: \*\* Feb. 23, 2021**

(54) **PART OF A RAIL VEHICLE**

(71) Applicant: **Bombardier Transportation GmbH,**  
Berlin (DE)

(72) Inventors: **Neil Simpson,** Bazemont (FR); **Michael Sohn,** Neuruppin (DE); **Alexandre Giroux,** Saint-Hubert (CA); **Martin Lessard,** St-Basile-le-Grand (CA)

(\*\*) Term: **15 Years**

(21) Appl. No.: **35/507,541**

(22) Filed: **Feb. 18, 2019**

(80) **Hague Agreement Data**

Int. Filing Date: **Feb. 18, 2019**

Int. Reg. No.: **DM/203463**

Int. Reg. Date: **Feb. 18, 2019**

Int. Reg. Pub. Date: **Oct. 25, 2019**

(51) **LOC (13) Cl.** ..... **12-03**

(52) **U.S. Cl.**  
USPC ..... **D12/37**

(58) **Field of Classification Search**  
USPC ..... **D12/36-39**  
See application file for complete search history.

(56) **References Cited**

**U.S. PATENT DOCUMENTS**

D188,475 S *	7/1960	Gurr	.....	D12/37
D205,105 S *	6/1966	Clary et al.	.....	D12/36
D206,838 S *	1/1967	Hawes	.....	D12/37
D292,971 S *	12/1987	Frech	.....	D12/37

D421,581 S *	3/2000	Dimson	.....	D12/37
D592,999 S *	5/2009	Chomiak	.....	D12/36
D596,988 S *	7/2009	Chomiak	.....	D12/36
D646,605 S *	10/2011	Okuyama	.....	D12/36
D827,493 S *	9/2018	Wang	.....	D12/37
D868,628 S *	12/2019	Lian	.....	D12/37

\* cited by examiner

*Primary Examiner* — George D. Kirschbaum

(74) *Attorney, Agent, or Firm* — Benoit & Côté Inc.

(57) **CLAIM**

The ornamental design for a part of a rail vehicle, as shown and described.

**DESCRIPTION**

2.-3. part of a rail vehicle

2.1 : Perspective

2.2 : Bottom

2.3 : Back

2.4 : Left

2.5 : Right

2.6 : Front

2.7 : Top

3.1 : Back

3.2 : Bottom

3.3 : Top

3.4 : Front

3.5 : Right

3.6 : Left

3.7 : Perspective

No protection is sought for the features illustrated by dashed lines.

**1 Claim, 14 Drawing Sheets**

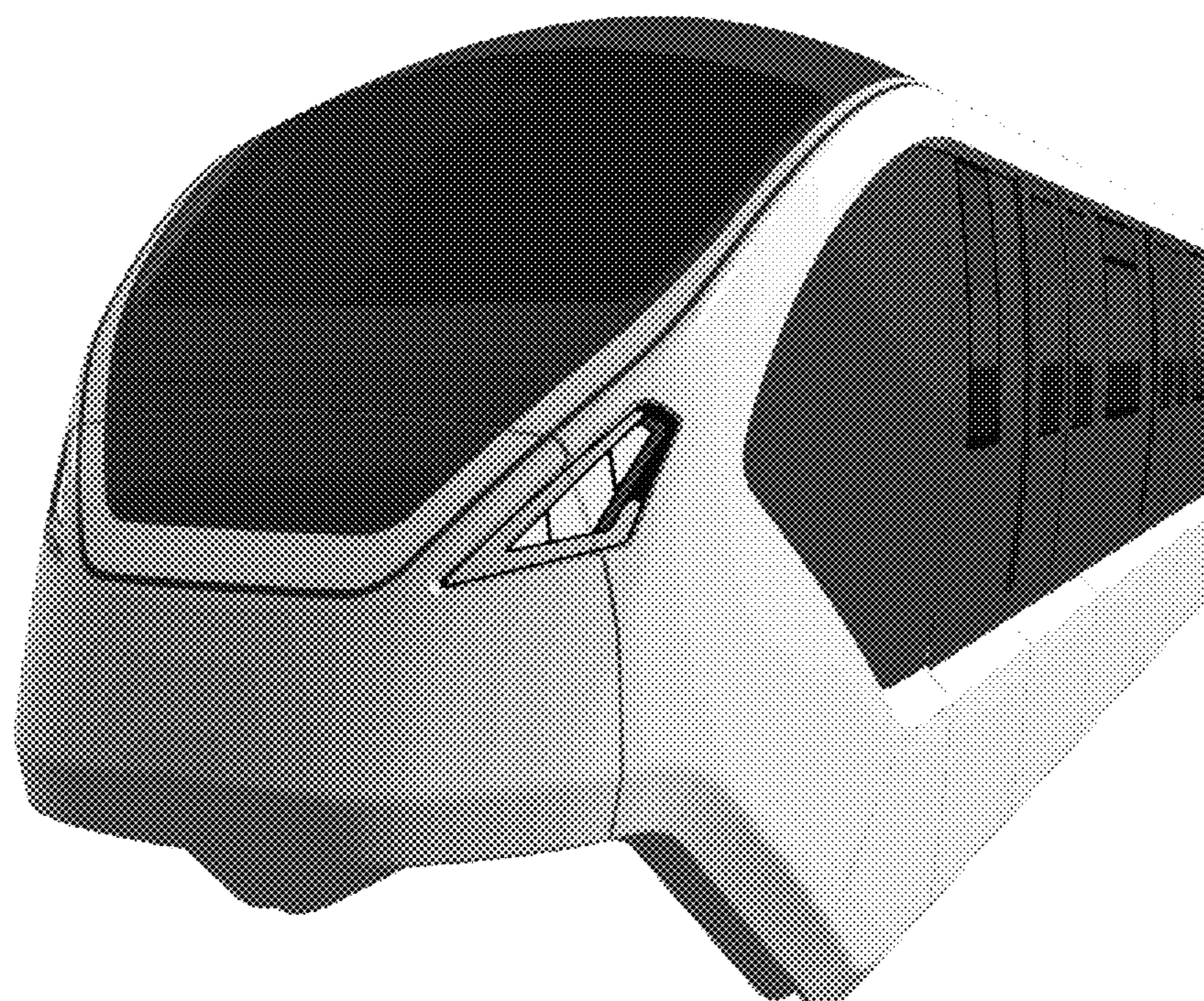

2.1

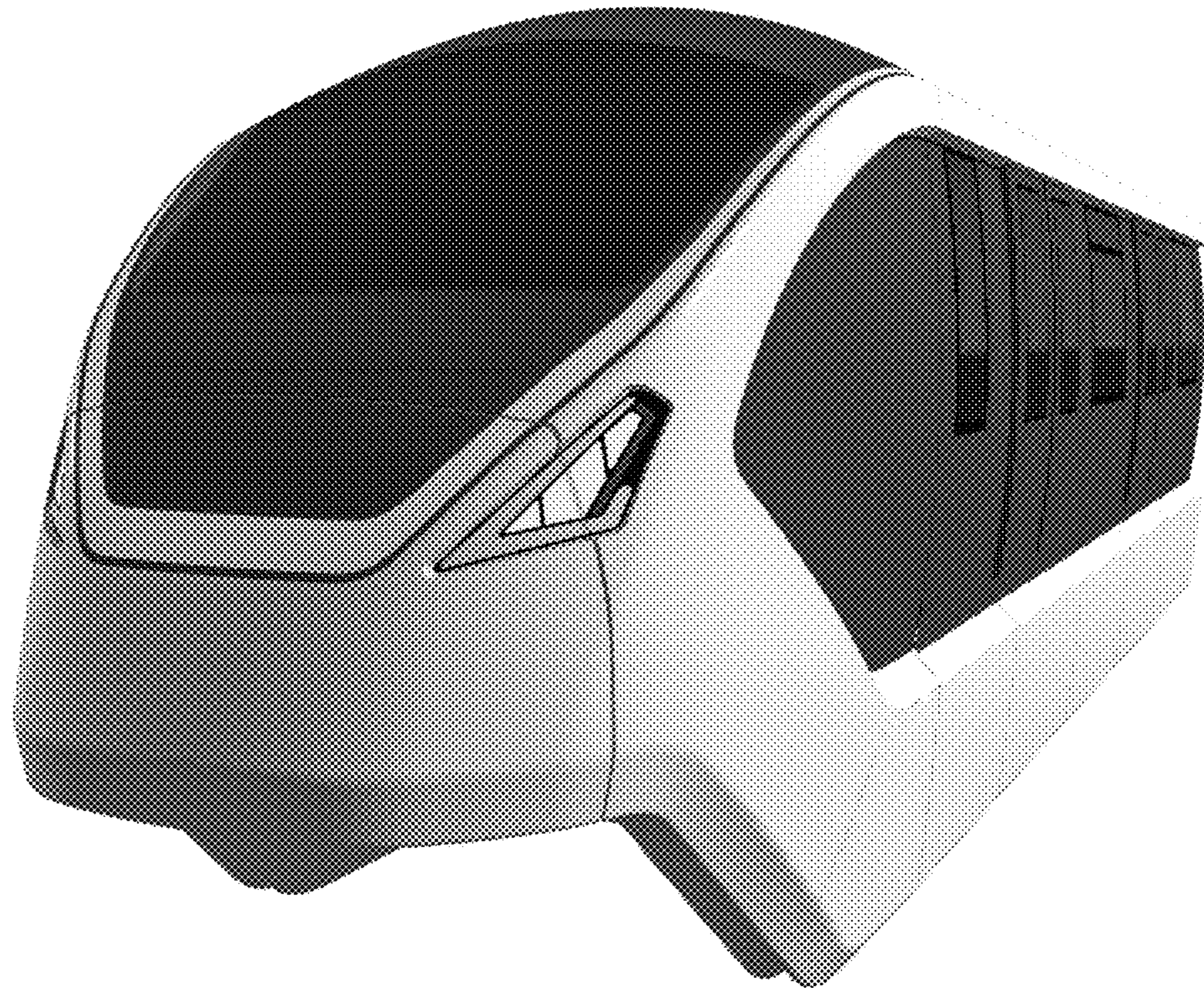

2.2

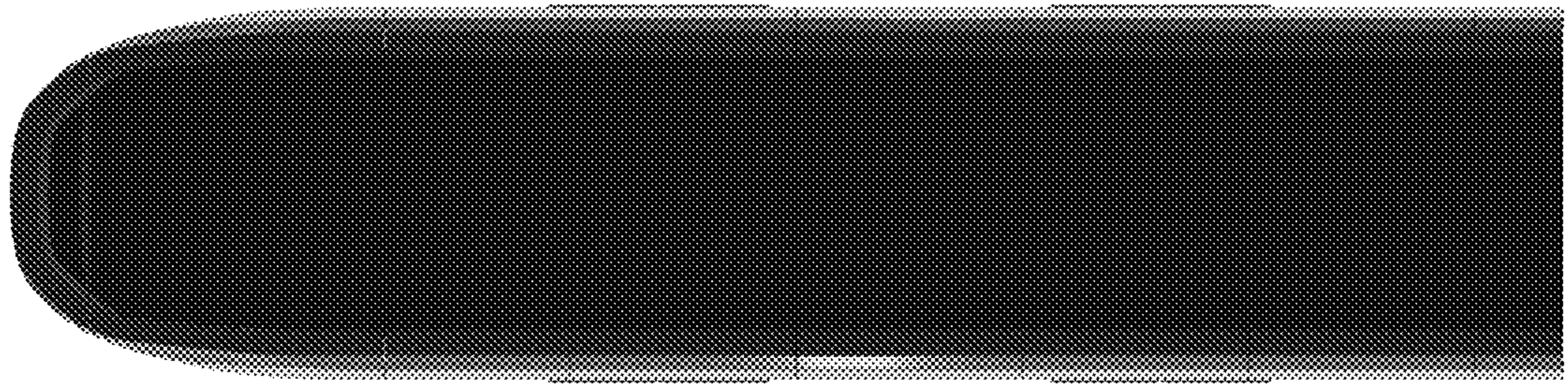

2.3



2.4

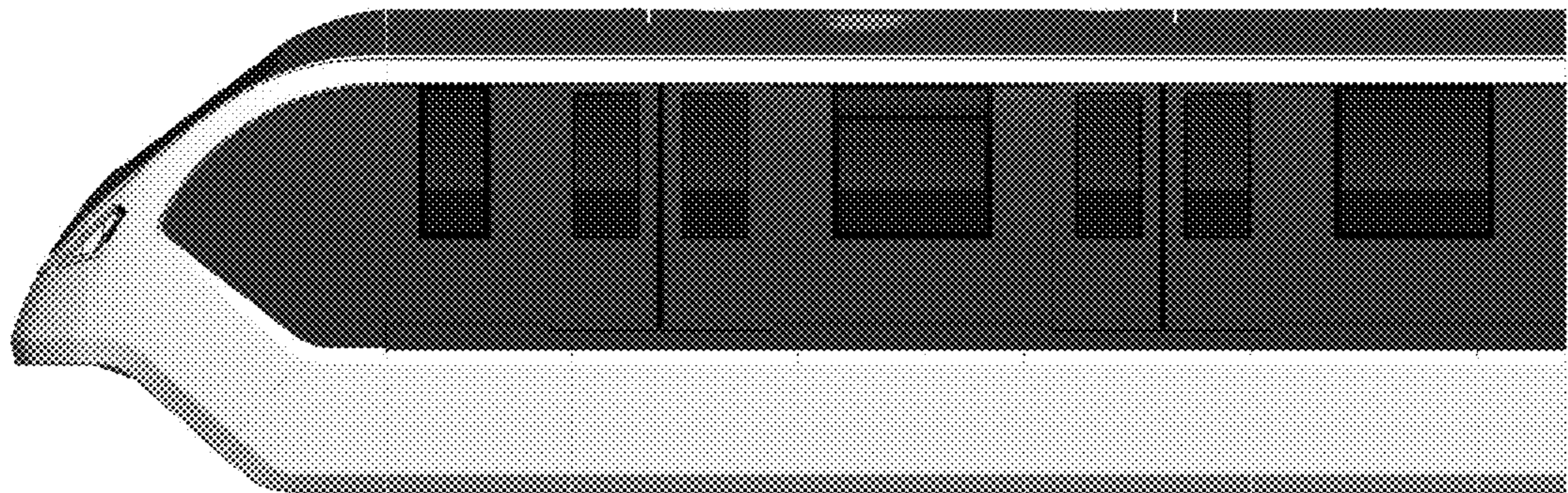

2.5

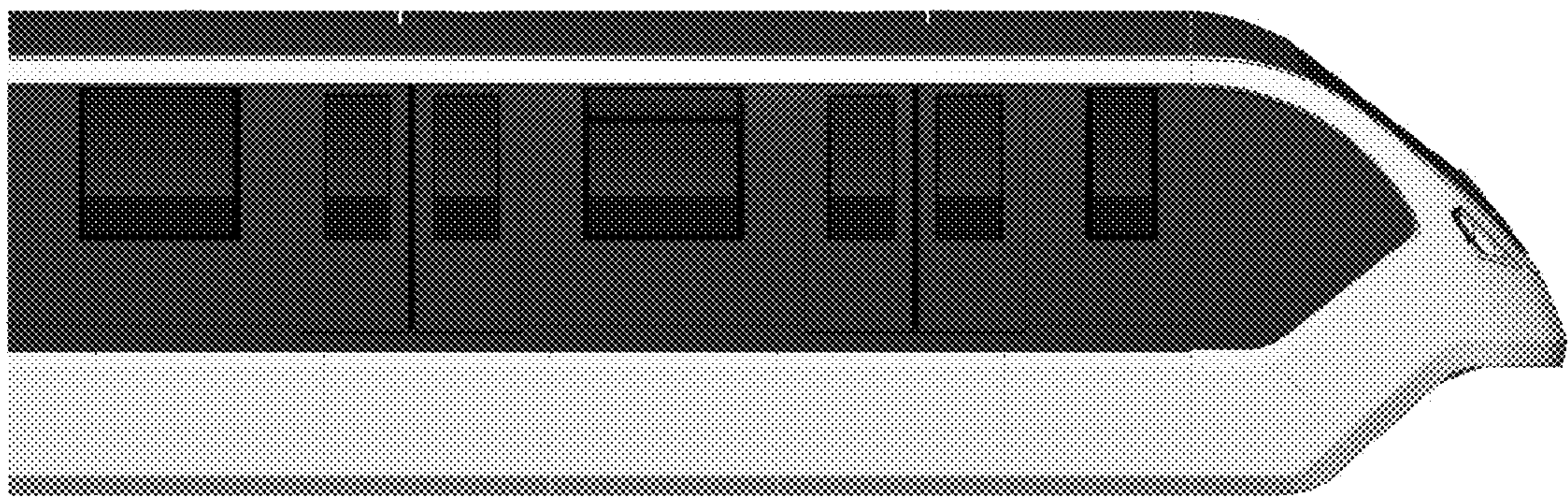

2.6

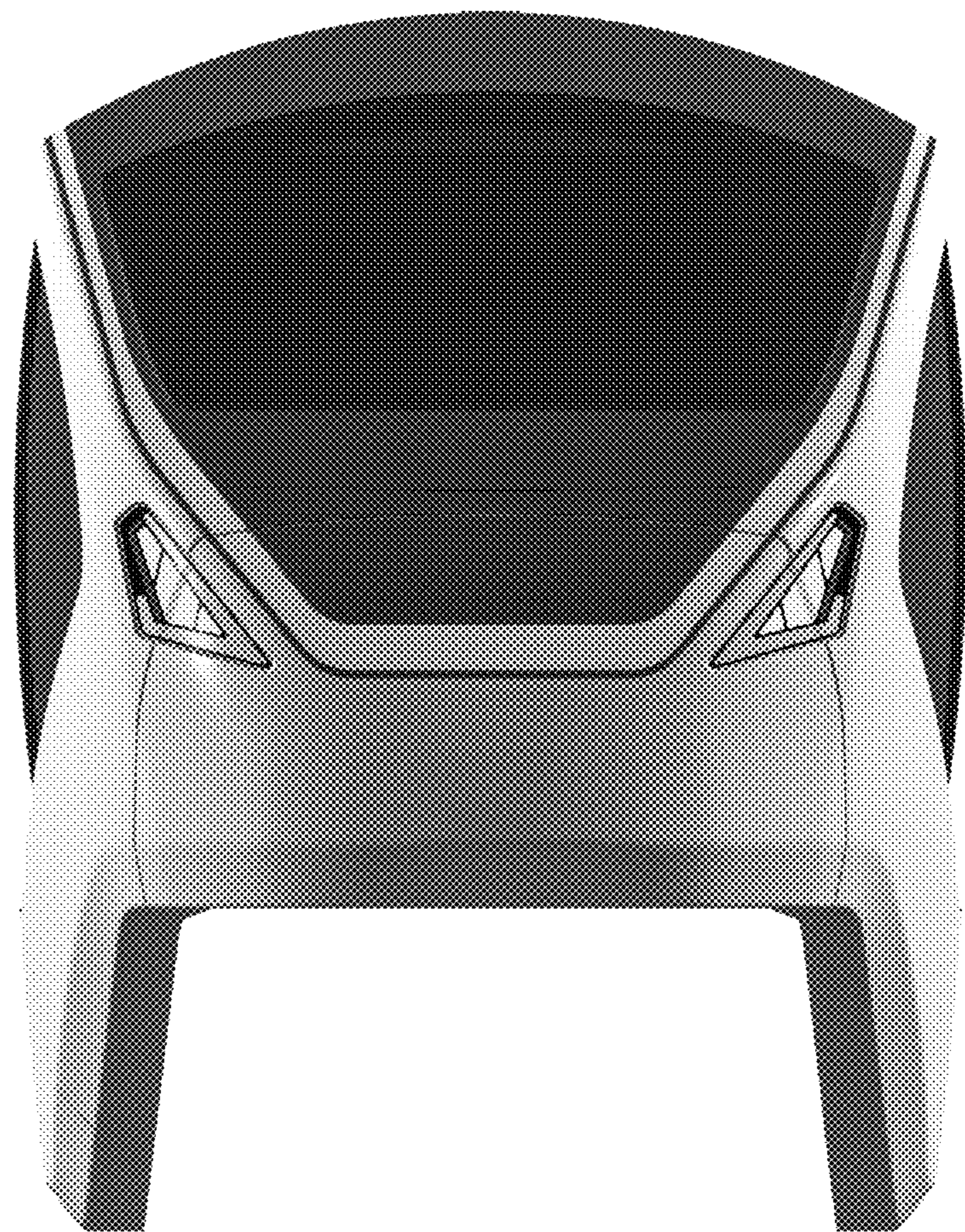

2.7

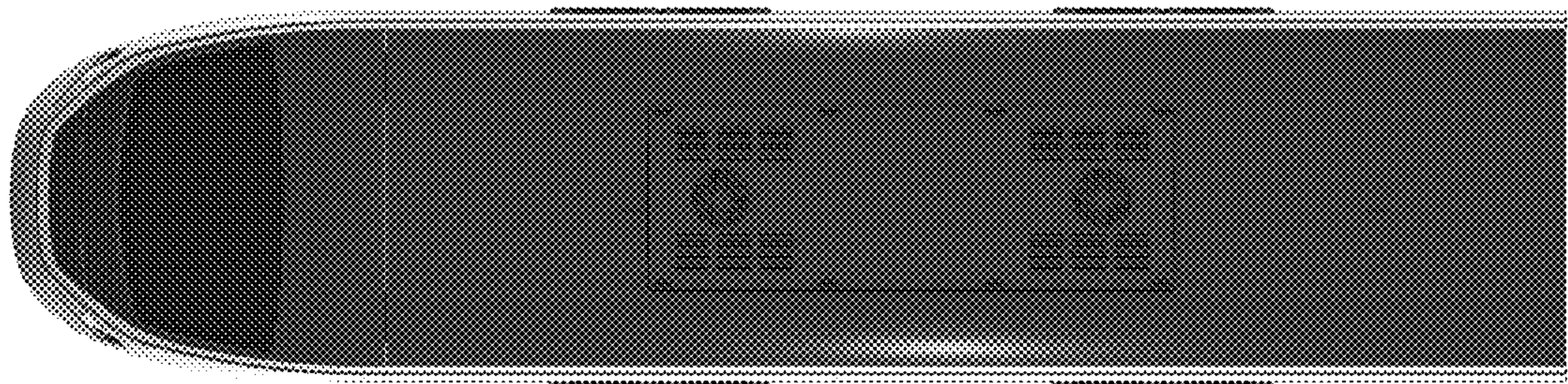



3.1

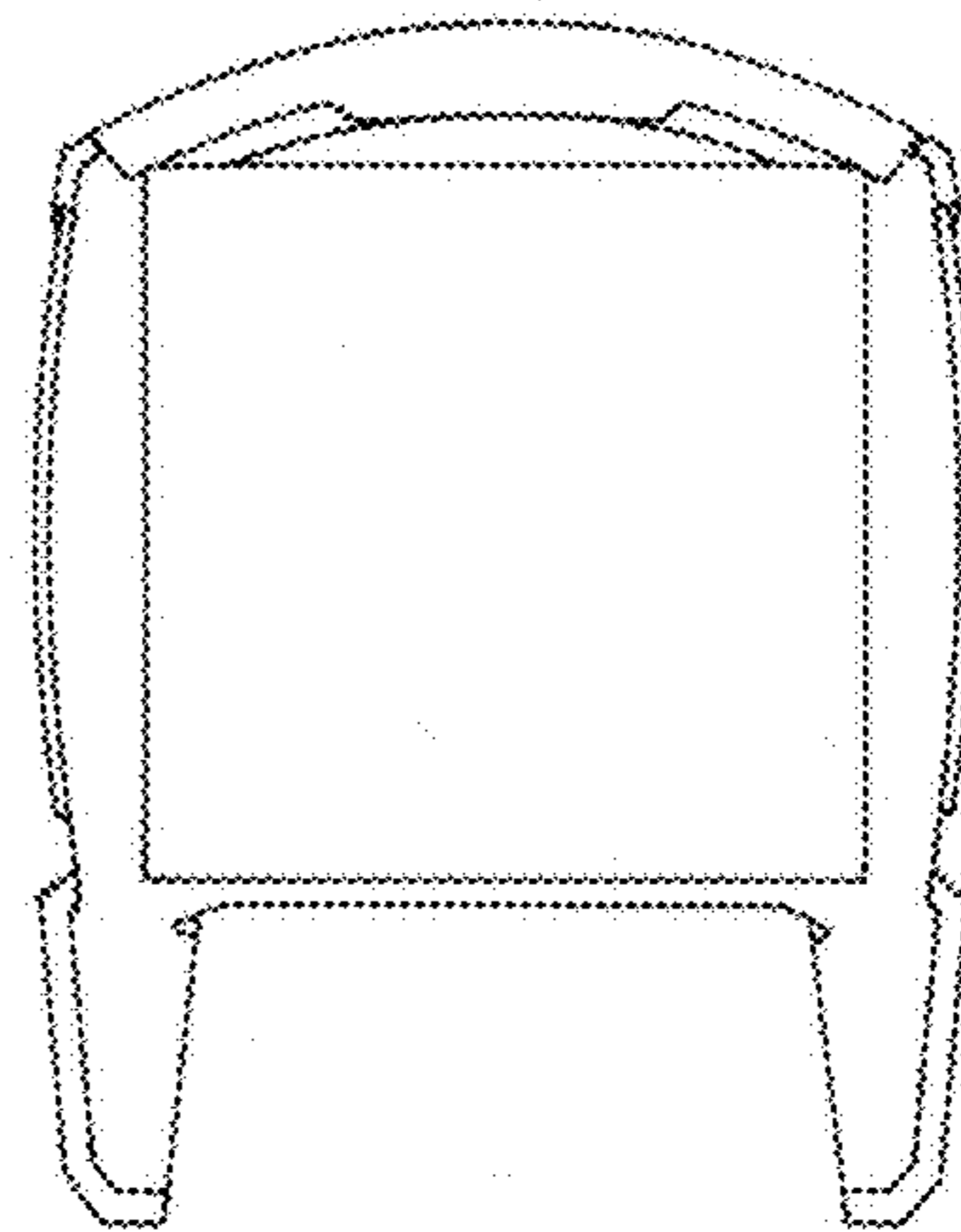

3.2

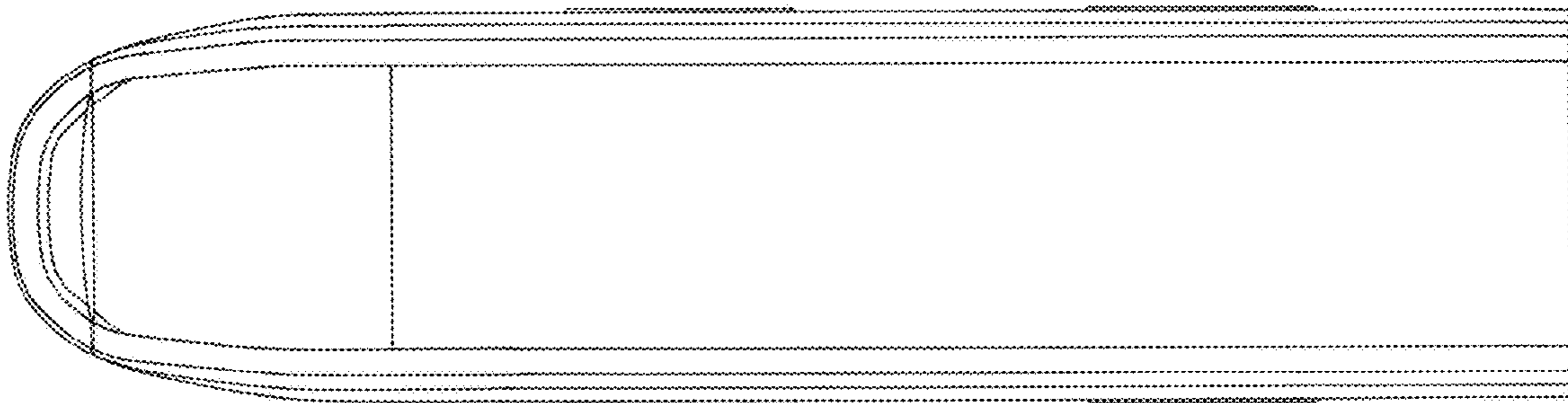

3.3

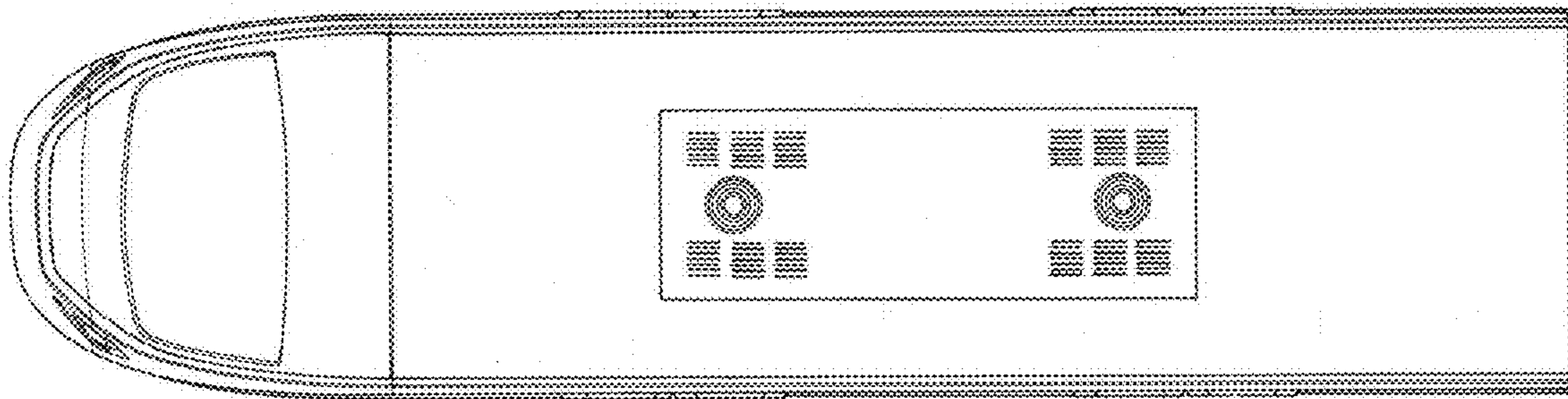

3.4

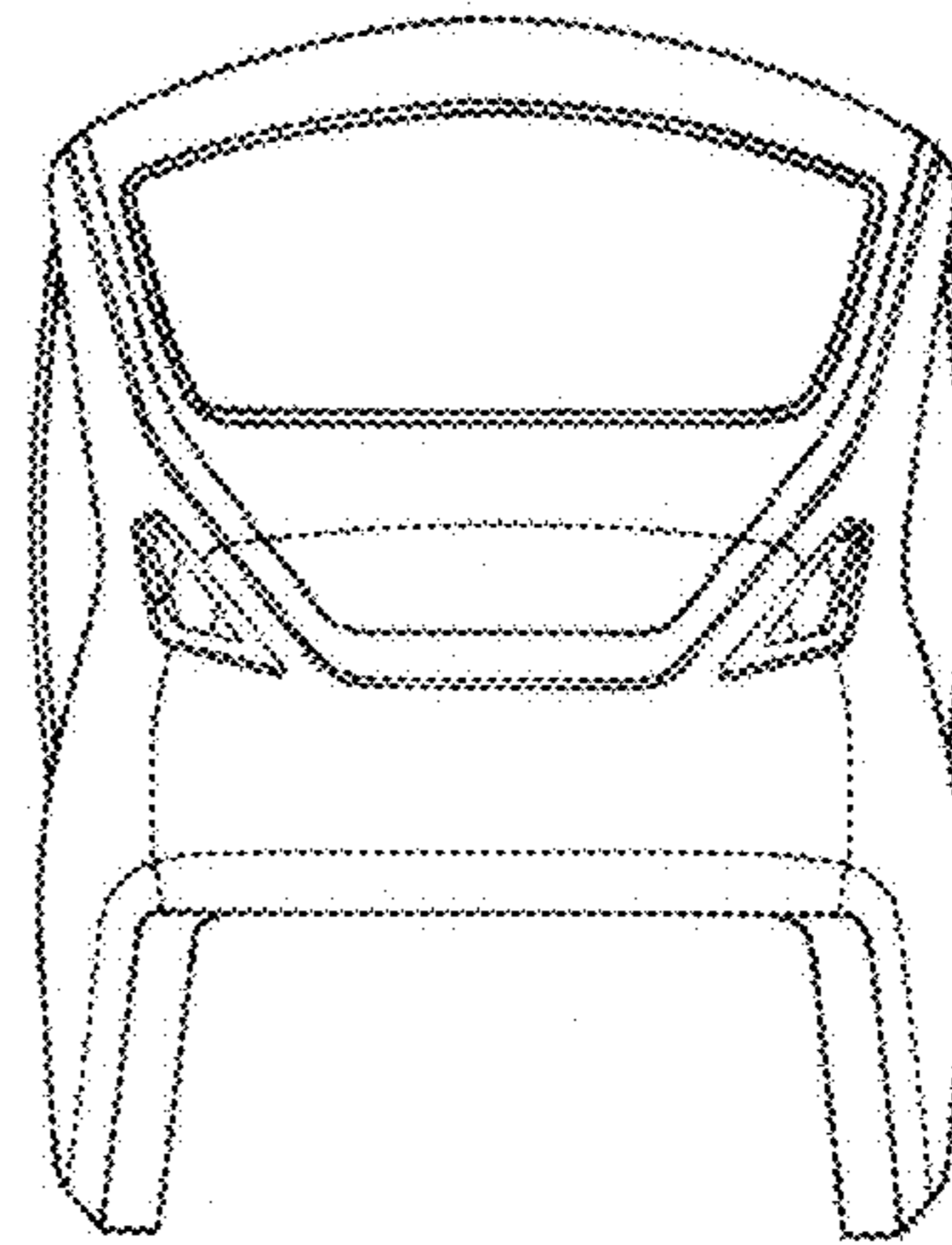

3.5

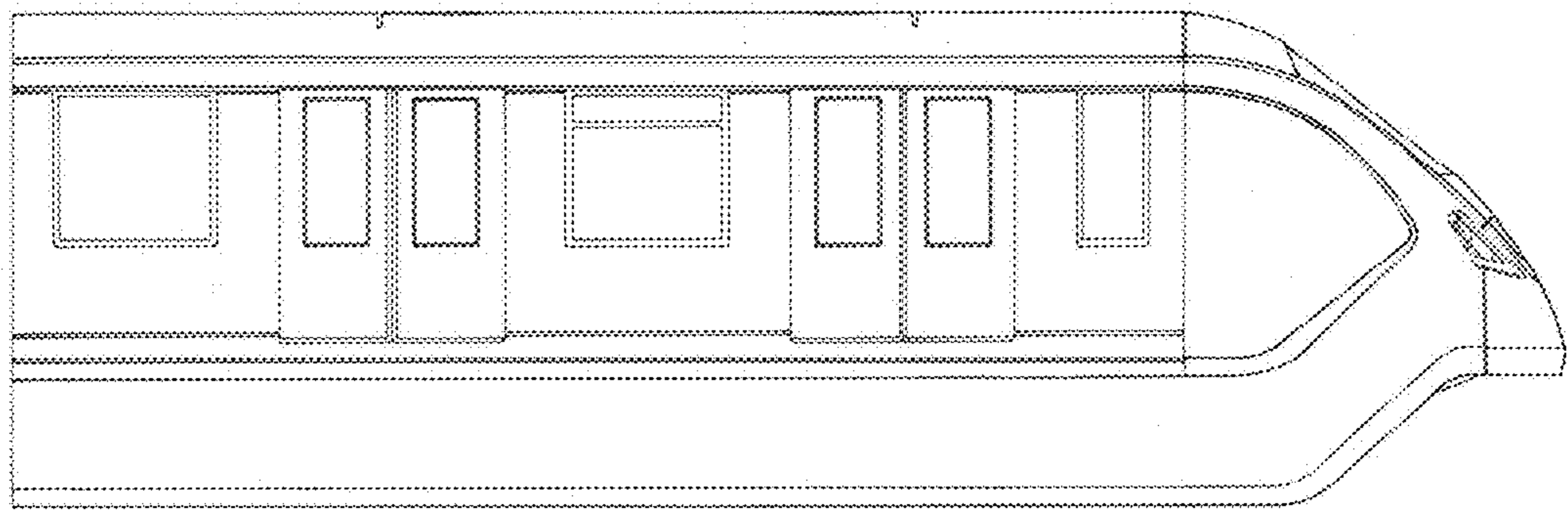

3.6

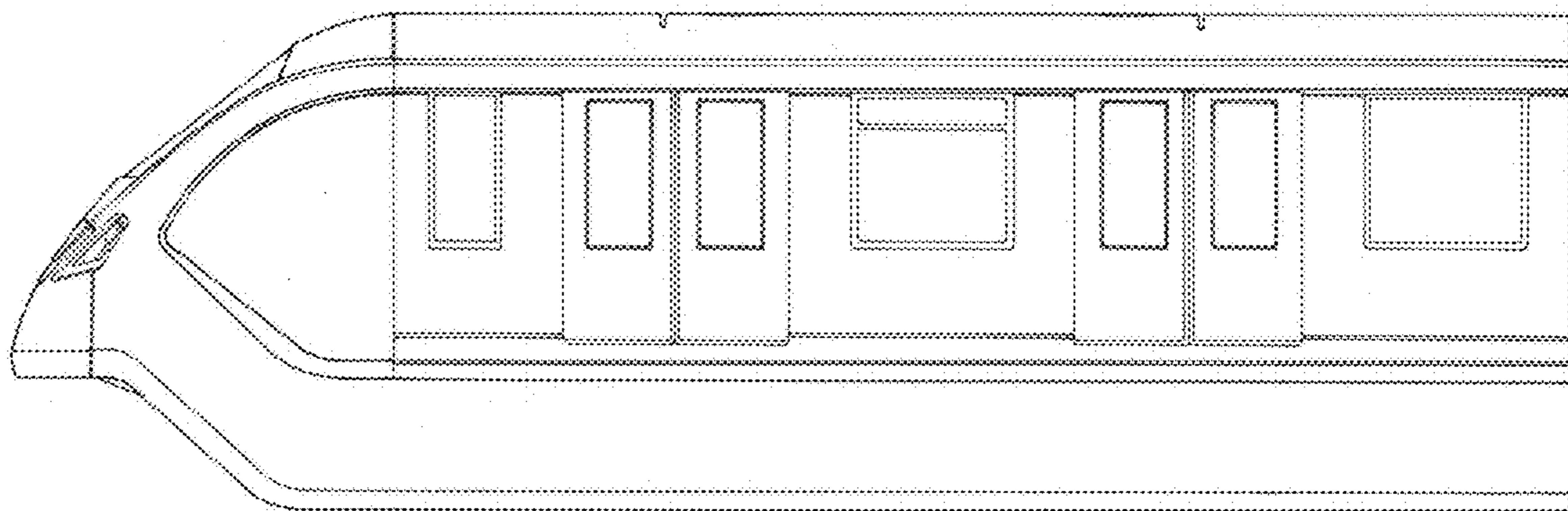

3.7

