



US00D910959S

(12) **United States Design Patent**  
**Layne**

(10) **Patent No.:** **US D910,959 S**

(45) **Date of Patent:** **\*\* Feb. 16, 2021**

- (54) **CONVEYOR GUIDERAIL**
- (71) Applicant: **SPAN TECH LLC**, Glasgow, KY (US)
- (72) Inventor: **James L. Layne**, Bowling Green, KY (US)
- (73) Assignee: **SPAN TECH LLC**, Glasgow, KY (US)
- (\*\*) Term: **15 Years**
- (21) Appl. No.: **29/659,785**
- (22) Filed: **Aug. 13, 2018**

D110,439 S \* 7/1938 Lowry ..... D25/119  
 2,156,020 A 4/1939 Lathrop et al.  
 2,229,605 A 1/1941 Snyder et al.  
 (Continued)

**FOREIGN PATENT DOCUMENTS**

DE 1244652 B 7/1967  
 GB 1521967 A 8/1978  
 JP 08058967 3/1996

**OTHER PUBLICATIONS**

Bethlehem Steel Extrusions Catalog 1951, Carbon Steel Bars—  
 Representative Sections—p. 11, Fourth shape from the left on row  
 9. (Year: 1951).\*

(Continued)

*Primary Examiner* — Cynthia Ramirez  
 (74) *Attorney, Agent, or Firm* — King & Schickli, PLLC

**Related U.S. Application Data**

- (63) Continuation of application No. PCT/US2018/033665, filed on May 21, 2018.
- (51) **LOC (13) Cl.** ..... **12-05**
- (52) **U.S. Cl.**  
USPC ..... **D34/29; D34/35**
- (58) **Field of Classification Search**  
USPC ..... D34/28, 35, 29; D23/267; D6/580;  
D25/35, 199; D26/85, 120; 198/502.01,  
198/781.06, 810.01, 836.3, 836.1, 837,  
198/861.1, 860.1  
CPC .. B07B 1/4645; B65G 21/2072; B65G 47/26;  
B65G 47/263; B65G 43/04; B65G 43/00;  
B65G 21/00; B65G 21/20; B65D 17/00  
See application file for complete search history.

(57) **CLAIM**

The ornamental design for a conveyor guiderail, as shown and described.

**DESCRIPTION**

FIG. 1 is a perspective view of a conveyor guiderail showing my new design;  
 FIG. 2 is a front view of the curved guiderail of FIG. 1;  
 FIG. 3 is a right view of the curved guiderail of FIG. 1;  
 FIG. 4 is a rear view of the curved guiderail of FIG. 1;  
 FIG. 5 is a front view of the curved guiderail of FIG. 1;  
 FIG. 6 is bottom view of the curved guiderail of FIG. 1; and,  
 FIG. 7 is a top view of the curved guiderail of FIG. 1.  
 The conveyor guiderail is shown with a symbolic in its length. The appearance of any portion of the article between the break lines forms no part of the claimed design. The broken line depictions illustrate the environment of use, and form no part of the claimed design.

(56) **References Cited**

**U.S. PATENT DOCUMENTS**

308,312 A \* 11/1884 Gardner ..... E04F 19/02  
52/716.1  
 1,208,481 A \* 12/1916 Cathcart ..... B65G 21/2072  
403/306  
 1,556,723 A 10/1925 Shaffer et al.  
 2,039,398 A \* 5/1936 Dye Edward R ..... B27M 3/004  
52/847

**1 Claim, 2 Drawing Sheets**

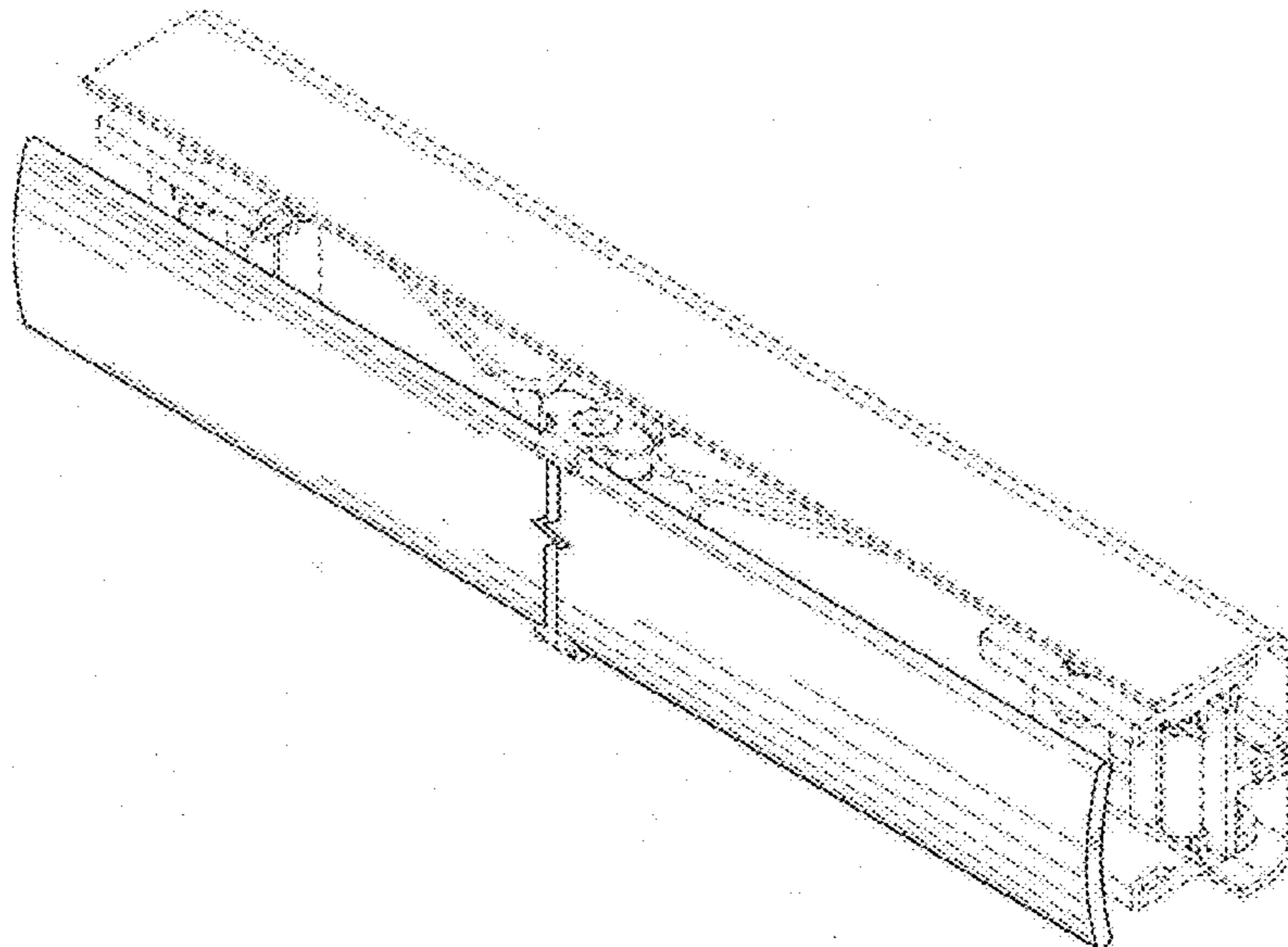

US D910,959 S

(56)	References Cited					
	U.S. PATENT DOCUMENTS					
2,300,545	A *	11/1942	Gouch ..... E06B 9/386 160/178.1 R	6,044,602	A *	4/2000 Canavan ..... E04B 7/12 52/200
D152,818	S *	2/1949	Nelson ..... D6/580	D433,782	S	11/2000 Carter
2,507,937	A *	5/1950	Slavsky ..... G09F 3/20 40/650	D448,494	S *	9/2001 Williams ..... D25/119
D168,258	S *	11/1952	Friedman ..... D6/580	6,328,154	B1 *	12/2001 Huber ..... B64D 9/00 198/781.06
D179,294	S	11/1956	Hinchcliffe	6,475,130	B1 *	11/2002 Simmons ..... B31D 5/0047 493/464
2,889,907	A	6/1959	Sullivan et al.	D472,418	S *	4/2003 Gilmore ..... D6/580
2,897,947	A	8/1959	Krupp et al.	6,588,578	B1 *	7/2003 Ernst ..... B65G 21/2072 198/502.1
D189,147	S	11/1960	Hinchcliffe	D479,885	S *	9/2003 O'Hagin ..... D25/143
2,979,806	A	4/1961	Stanley et al.	6,612,426	B1 *	9/2003 Guerra ..... B65G 21/06 198/841
3,042,742	A *	7/1962	Foster ..... F21V 21/16 174/69	6,619,367	B1 *	9/2003 Kawakita ..... E06B 9/28 160/172 R
3,110,066	A	11/1963	Ward et al.	6,619,473	B2	9/2003 Romeo
3,146,874	A	9/1964	Mcgow et al.	D481,575	S *	11/2003 Steinberg ..... D6/580
3,191,749	A	6/1965	Hawley et al.	D487,160	S *	2/2004 Forbis ..... D25/126
3,200,967	A	8/1965	Giuseppe et al.	D495,549	S *	9/2004 Yu ..... D6/577
3,330,080	A *	7/1967	Grieb ..... E04B 7/08 52/86	D501,348	S *	2/2005 Yu ..... D6/577
D209,071	S	10/1967	Koch	D504,524	S *	4/2005 Lookman ..... D25/119
3,349,534	A *	10/1967	Wotherspoon ..... E04D 1/045 52/520	6,889,823	B2	5/2005 DelaPorte
3,507,379	A	4/1970	Johnston et al.	D515,266	S	2/2006 Moe
3,545,169	A	12/1970	Nash et al.	D532,911	S *	11/2006 Gardner ..... D25/136
3,776,350	A	12/1973	Tice	7,302,894	B2	12/2007 Belanger et al.
3,843,182	A	10/1974	Walls et al.	D562,992	S	2/2008 Szczekocki
3,897,869	A	8/1975	Michael	D568,573	S *	5/2008 Kamamoto ..... D34/29
4,015,537	A	4/1977	Graef et al.	D590,197	S *	4/2009 Shiue ..... D6/577
4,214,744	A	7/1980	Evans	D594,623	S	6/2009 Felton
D259,552	S	6/1981	Lindfors	D617,521	S	6/2010 Swinderman
4,273,239	A *	6/1981	Thwaites ..... B65G 47/261 198/781.06	7,823,719	B2 *	11/2010 Jaksic ..... B65G 39/02 198/781.05
4,293,065	A *	10/1981	Dyer ..... B65G 47/261 198/781.06	D636,501	S *	4/2011 Shanes ..... D25/139
4,330,057	A	5/1982	Binns	D660,461	S *	5/2012 Kotin ..... D25/119
4,406,360	A *	9/1983	Smith ..... B65G 47/261 198/781.06	D697,656	S *	1/2014 Sabernig ..... D26/122
4,533,173	A	8/1985	Davis	D698,583	S *	2/2014 Lin ..... D6/577
4,582,192	A	4/1986	Rojlar	D699,050	S *	2/2014 Lin ..... D6/577
4,658,731	A	4/1987	Schumann	D710,564	S	8/2014 Yang
4,791,453	A	12/1988	Koseki et al.	D740,514	S	10/2015 Peterson et al.
4,930,621	A	6/1990	Brown	D764,140	S	8/2016 Holzhaeuser
D313,685	S	1/1991	Johansson et al.	D771,277	S	11/2016 McCue et al.
4,983,836	A	1/1991	Matoba et al.	D783,223	S	4/2017 Peterson et al.
4,989,721	A	2/1991	Ach	D783,914	S	4/2017 Supthut
5,005,693	A *	4/1991	Fultz ..... B65G 47/263 198/781.06	D789,643	S	6/2017 Pettinga
5,038,087	A *	8/1991	Archer ..... E06B 9/88 160/310	D790,799	S	6/2017 Holzhaeuser
5,042,644	A *	8/1991	Davis ..... B65G 47/263 198/781.06	9,776,836	B2	10/2017 Spies et al.
5,066,834	A	11/1991	Richter	D816,267	S	4/2018 Fornarelli
5,074,407	A	12/1991	Brumby	D828,946	S *	9/2018 McVey ..... D26/85
5,139,131	A	8/1992	Persson	10,087,012	B1	10/2018 Layne
5,150,655	A	9/1992	Sakai	D837,347	S *	1/2019 Brochu ..... D23/267
5,161,670	A	11/1992	David	D868,499	S *	12/2019 Hsu ..... D6/580
5,201,910	A	4/1993	Sheeter	10,544,619	B2 *	1/2020 Hall ..... B01J 23/26
5,211,278	A	5/1993	Mendenhall	D878,701	S *	3/2020 Specht ..... D34/29
5,277,295	A	1/1994	Grecksch et al.	2003/0116410	A1	6/2003 Ledingham
5,287,956	A *	2/1994	Collins ..... B65G 47/263 198/781.04	2004/0035685	A1	2/2004 Fujiwara et al.
D355,092	S *	2/1995	Swopes ..... D6/577	2006/0027347	A1	2/2006 Boehm et al.
5,501,156	A	3/1996	Richter	2007/0251803	A1 *	11/2007 Schill ..... B21D 51/2692 198/418.2
D371,667	S	7/1996	Poole	2007/0295582	A1 *	12/2007 DePaso ..... B65G 17/24 198/837
D376,460	S	12/1996	Isaia et al.	2008/0092680	A1 *	4/2008 Kim ..... H01L 21/67748 74/89.31
D376,461	S	12/1996	Graf	2008/0110731	A1 *	5/2008 Vestergaard ..... B65G 13/12 198/860.3
D381,177	S	7/1997	Patois et al.	2010/0044281	A1	2/2010 Johnson et al.
5,649,617	A *	7/1997	Fortenbery ..... B65G 47/263 198/781.03	2010/0059342	A1 *	3/2010 Willi ..... B65G 13/04 198/789
5,685,415	A	11/1997	East	2010/0206699	A1 *	8/2010 Petrovic ..... B65G 21/2072 198/836.3
D409,869	S *	5/1999	Marusak ..... D6/577	2010/0258409	A1 *	10/2010 Kas ..... B65G 21/2054 198/836.1
5,947,361	A	9/1999	Berger	2015/0068871	A1 *	3/2015 Tachibana ..... G05B 19/042 198/502.1
5,954,186	A *	9/1999	Stroobandt ..... B65G 43/04 198/502.4	2016/0107841	A1 *	4/2016 Spaulding ..... B65G 27/32 198/502.1
				2016/0161520	A1 *	6/2016 Pedrazzini ..... G01N 35/02 198/571

(56)

**References Cited**

U.S. PATENT DOCUMENTS

2017/0342717 A1\* 11/2017 Brochu ..... E04D 13/076  
2019/0062063 A1\* 2/2019 Baek ..... B65G 21/14  
2019/0376833 A1\* 12/2019 Merz ..... B65G 47/28

OTHER PUBLICATIONS

Google search Aug. 14, 2020, [https://www.alibaba.com/product-detail/E0-Glue-Wooden-LVL-Slat-Curved\\_62596752124.html?spm=a2700.7724857.normalList.47.56c74ce3viQ898](https://www.alibaba.com/product-detail/E0-Glue-Wooden-LVL-Slat-Curved_62596752124.html?spm=a2700.7724857.normalList.47.56c74ce3viQ898), Glue wooden Slat (Year: 2020).\*

Google search Aug. 14, 2020, [https://www.alibaba.com/product-detail/Linyi-Bent-Curved-LVL-Wood-Bed\\_62392080092.html?spm=a2700.7724857.normalList.32.56c74ce3viQ898](https://www.alibaba.com/product-detail/Linyi-Bent-Curved-LVL-Wood-Bed_62392080092.html?spm=a2700.7724857.normalList.32.56c74ce3viQ898), Linyi Bent Curved Wood Bed Slat (Year: 2020).\*

Google search Aug. 14, 2020, <https://cnxdsjwj.en.made-in-china.com/product/aBsESMTOAtho/China-2-Curved-Slat-Ready-Made-Blinds.html>, 2" curved slat ready made blids (Year: 2020).\*

Google search Aug. 14, 2020, <https://www.slideways.com/collections/uhmw-guide-rails>, UHMW Guide Rails (Year: 2020).\*

Google search Aug. 13, 2020, <http://www.extrusionprofiles.com/> (Year: 2020).\*

Google search Aug. 14, 2020, <https://eagle-aluminum.com/product/stainless-steel-oval-1-x-075-half-oval/>, stainless steel oval 1" face (Year: 2020).\*

Google search Oct. 7, 2020, <https://buymbs.com/p-2929-fypon-polyurethane-crown-moulding.aspx>, Fypon Polyurethane crown moulding (Year: 2020).\*

Google search Oct. 7, 2020, <https://www.millwork.com/8-h-x-8-p-16-length-cove-moulding.html>, 8hX8p, 16 cove moulding (Year: 2020).\*

\* cited by examiner

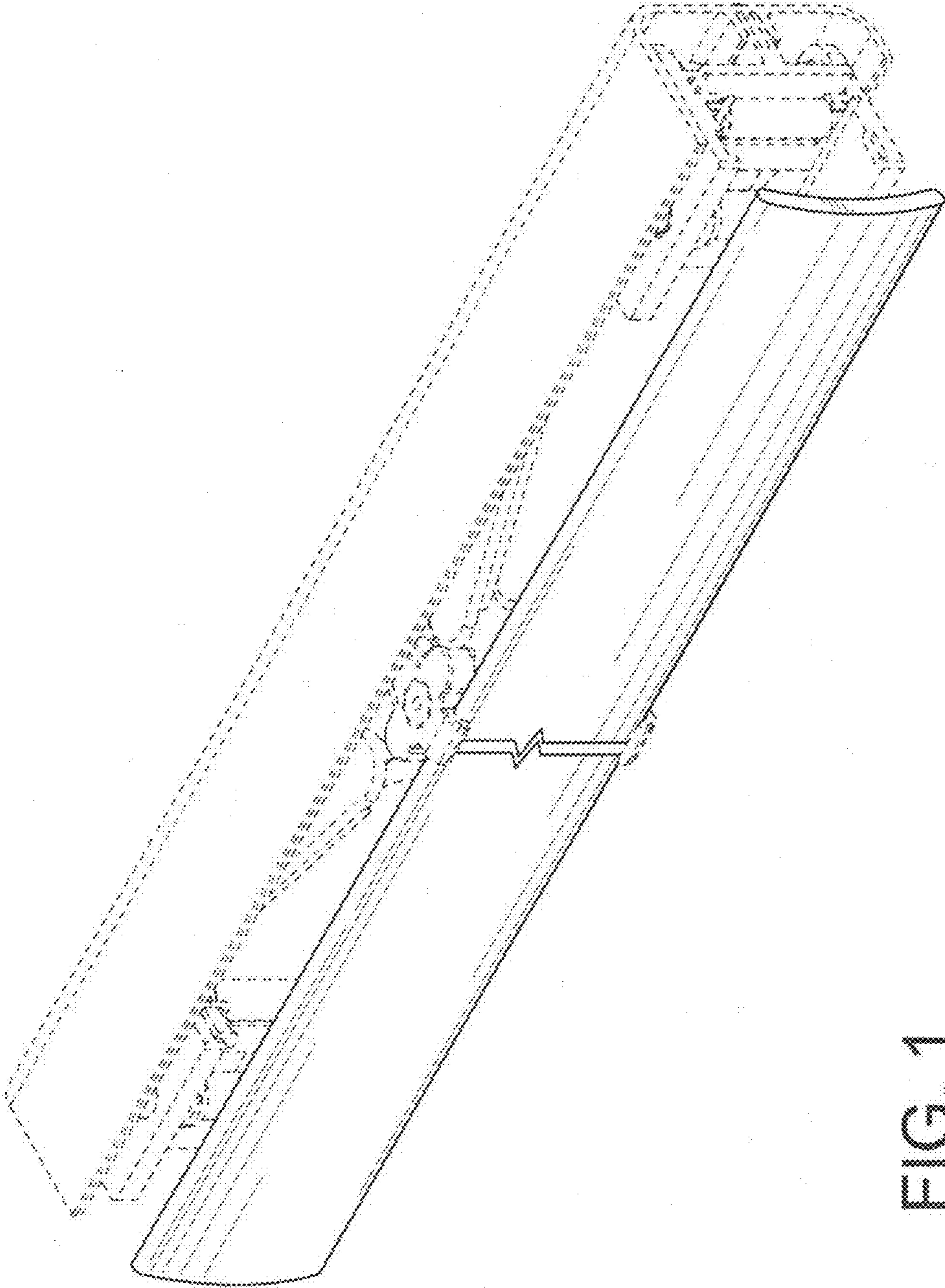

FIG. 1

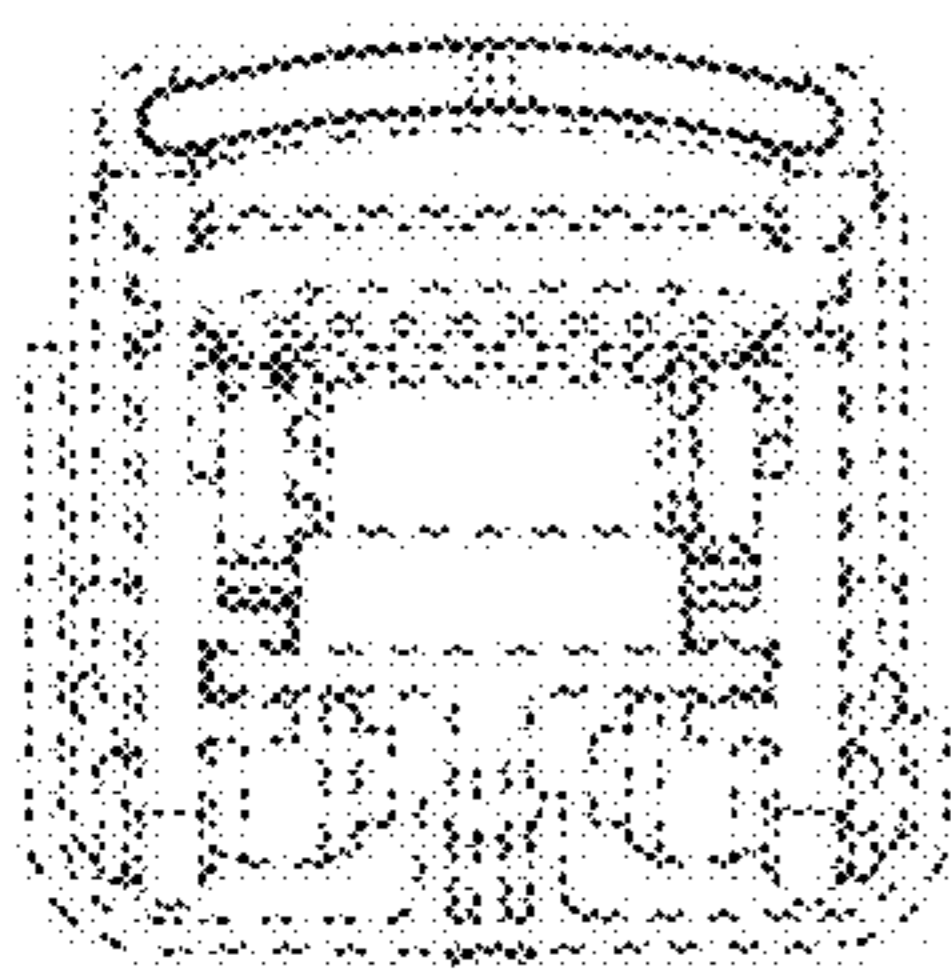

FIG. 3

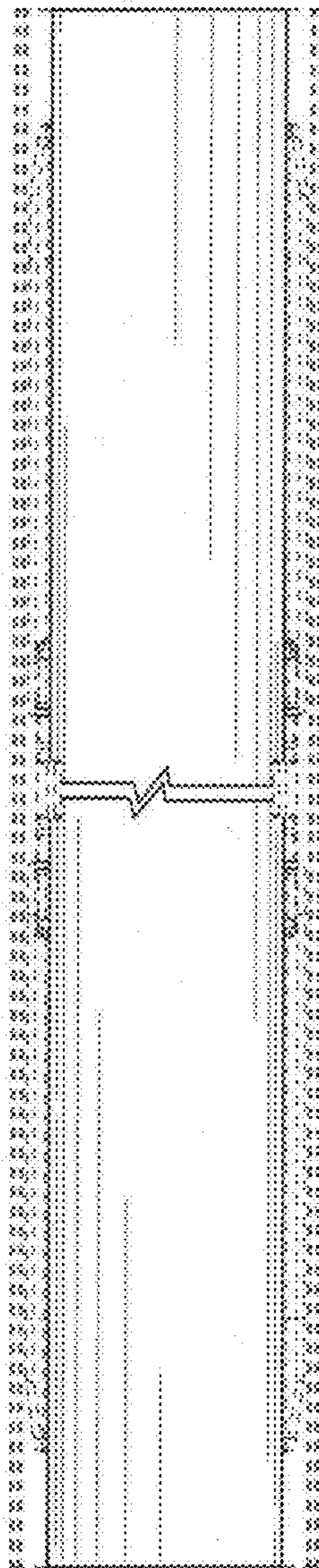

FIG. 2

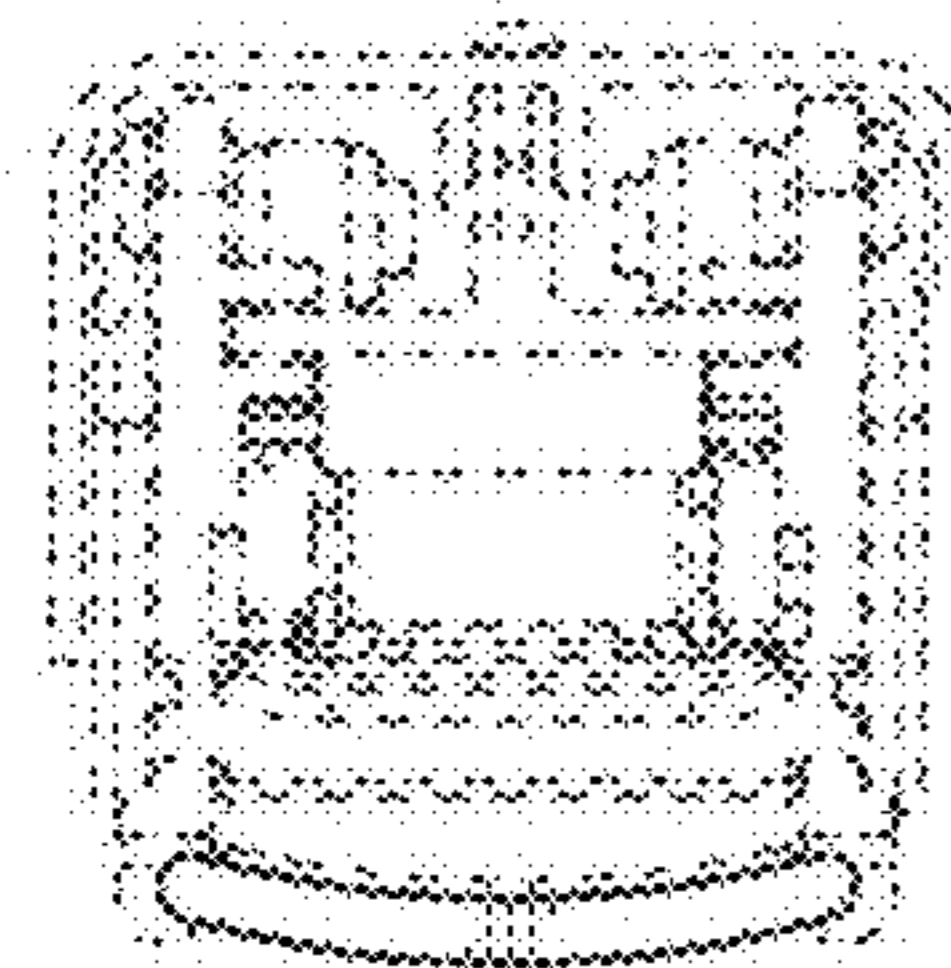

FIG. 5

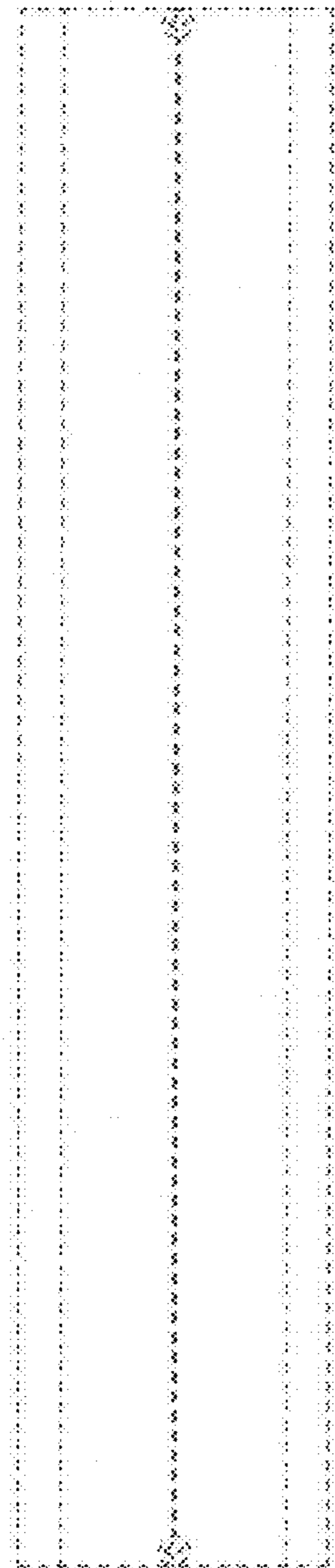

FIG. 4

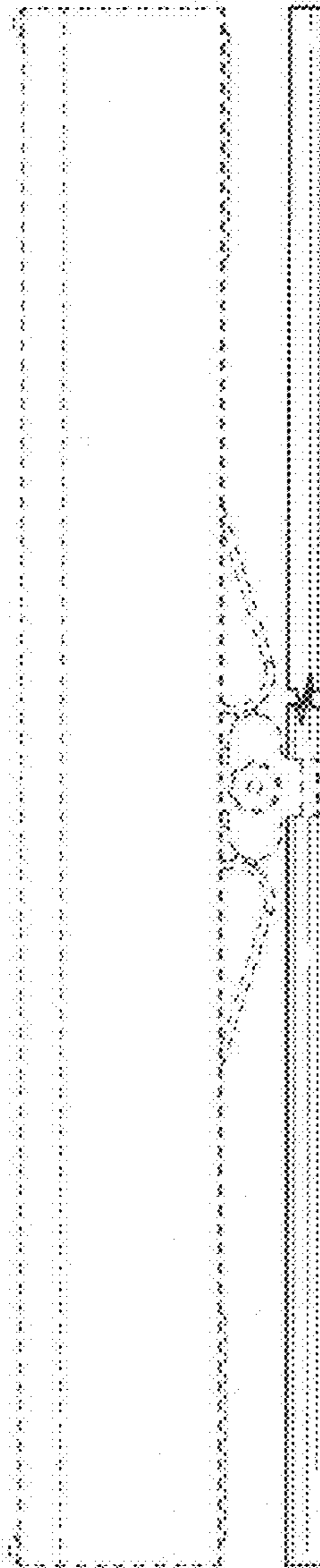

FIG. 6

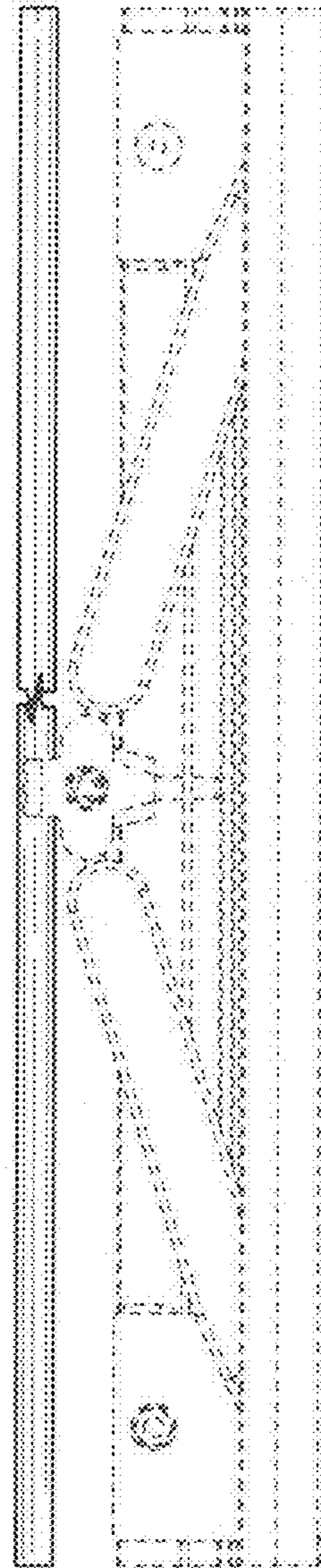

FIG. 7