



US00D910954S

(12) **United States Design Patent**  
**Hokanson**

(10) **Patent No.:** **US D910,954 S**

(45) **Date of Patent:** **\*\* Feb. 16, 2021**

(54) **SKID-STEER HYDRAULIC BREAKER RACK**

(71) Applicant: **Craig Richard Hokanson**, Clearfield,  
UT (US)

(72) Inventor: **Craig Richard Hokanson**, Clearfield,  
UT (US)

(\*\*) Term: **15 Years**

(21) Appl. No.: **29/683,468**

(22) Filed: **Mar. 13, 2019**

(51) **LOC (13) Cl.** ..... **12-02**

(52) **U.S. Cl.**  
USPC ..... **D34/12**

(58) **Field of Classification Search**  
USPC ..... D15/138, 199; D34/12, 14, 17, 20, 21,  
D34/26, 27, 28, 30, 33, 34, 35  
CPC ..... A47B 47/024; A47B 47/028  
See application file for complete search history.

(56) **References Cited**

U.S. PATENT DOCUMENTS

D271,719 S *	12/1983	Streiff .....	D34/24
D307,150 S *	4/1990	Hemmingsen .....	D15/138
D367,144 S *	2/1996	Poskocil .....	D34/28
D367,747 S *	3/1996	Poskocil .....	D34/28
D474,870 S *	5/2003	Post .....	D34/12
D483,540 S *	12/2003	Murray .....	D34/12
D630,814 S *	1/2011	Smith .....	D34/12
D746,530 S *	12/2015	Marchant .....	D34/26
D757,388 S *	5/2016	Rocha .....	D34/26
D764,735 S *	8/2016	Avery .....	D34/12

D782,145 S *	3/2017	Bowen .....	D34/12
D793,023 S *	7/2017	Kueck .....	D34/28
D810,379 S *	2/2018	Sarian .....	D34/17
D831,922 S *	10/2018	Melendez .....	D34/12
D858,926 S *	9/2019	Sukhov .....	D34/12
2016/0157637 A1 *	6/2016	Hokanson .....	B65G 1/02 211/85.8
2017/0020283 A1 *	1/2017	Hokanson .....	A47B 81/00

\* cited by examiner

*Primary Examiner* — Michael C Stout

*Assistant Examiner* — Fritzgerald L Butac

(74) *Attorney, Agent, or Firm* — Steven Rinehart

(57) **CLAIM**

I claim the ornamental design for the skid-steer hydraulic breaker rack, as shown and described.

**DESCRIPTION**

FIG. 1 shows top, front, right side perspective view of a skid-steer hydraulic breaker rack in accordance with the present invention;  
FIG. 2 is another top, front, right side perspective view, in an environment of use thereof;  
FIG. 3 is a front elevation view thereof;  
FIG. 4 is a left side elevation view thereof;  
FIG. 5 is a right side elevation view thereof;  
FIG. 6 is a top plan view thereof; and,  
FIG. 7 is a rear elevation view thereof.  
The broken lines in the drawings are for the purpose of showing environmental structure and form no part of the claimed design.

**1 Claim, 7 Drawing Sheets**

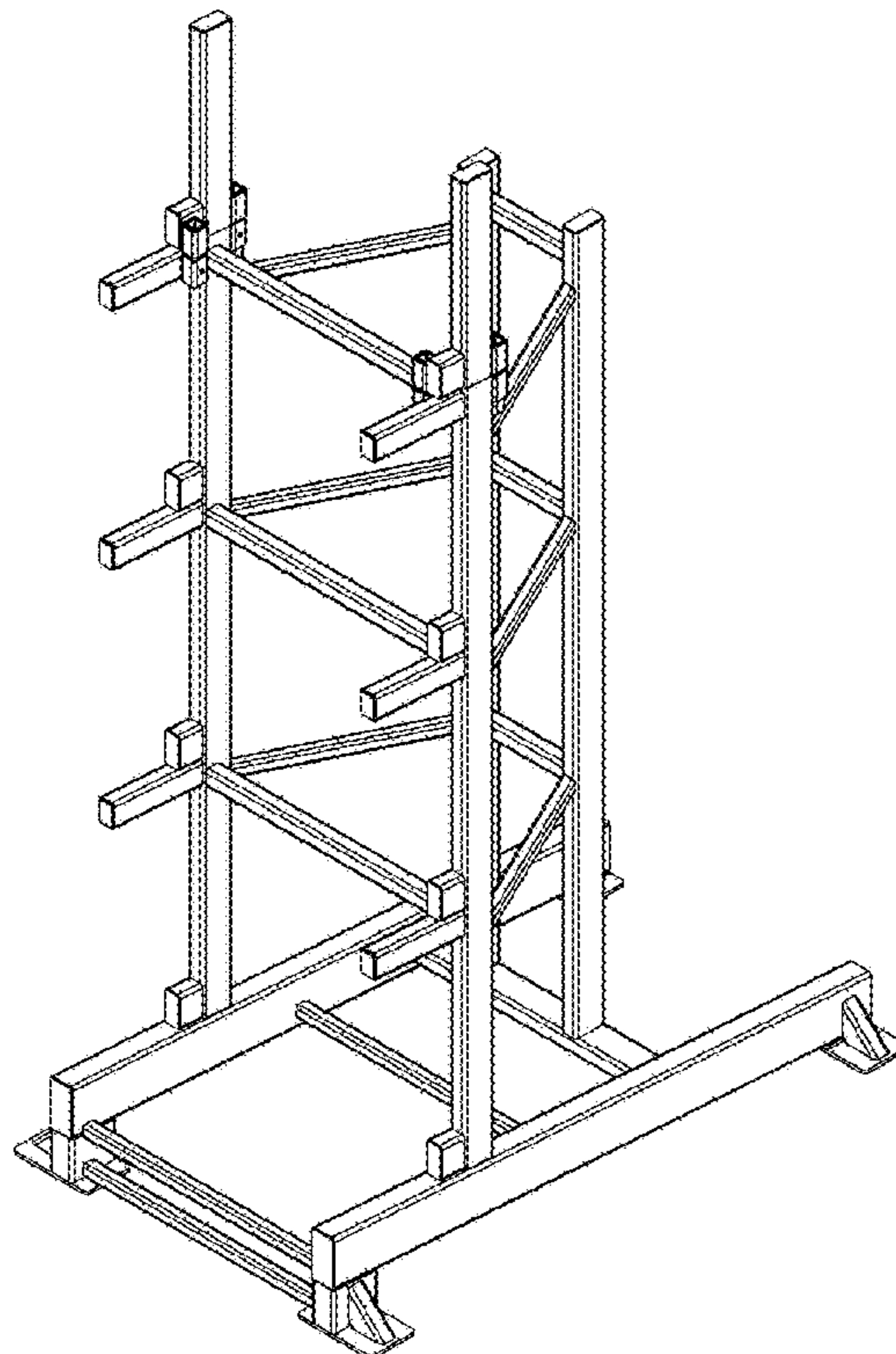

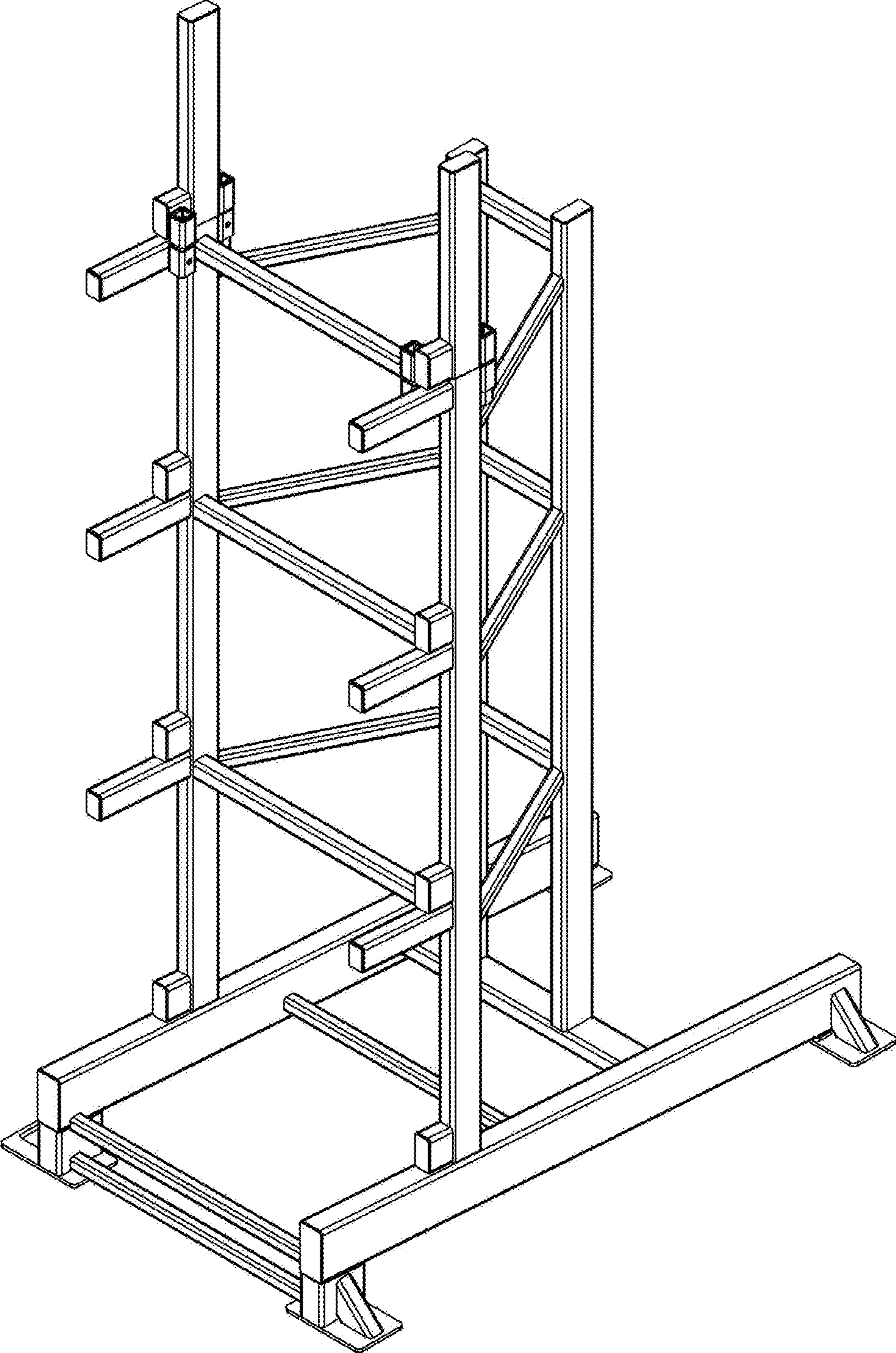

FIG. 1

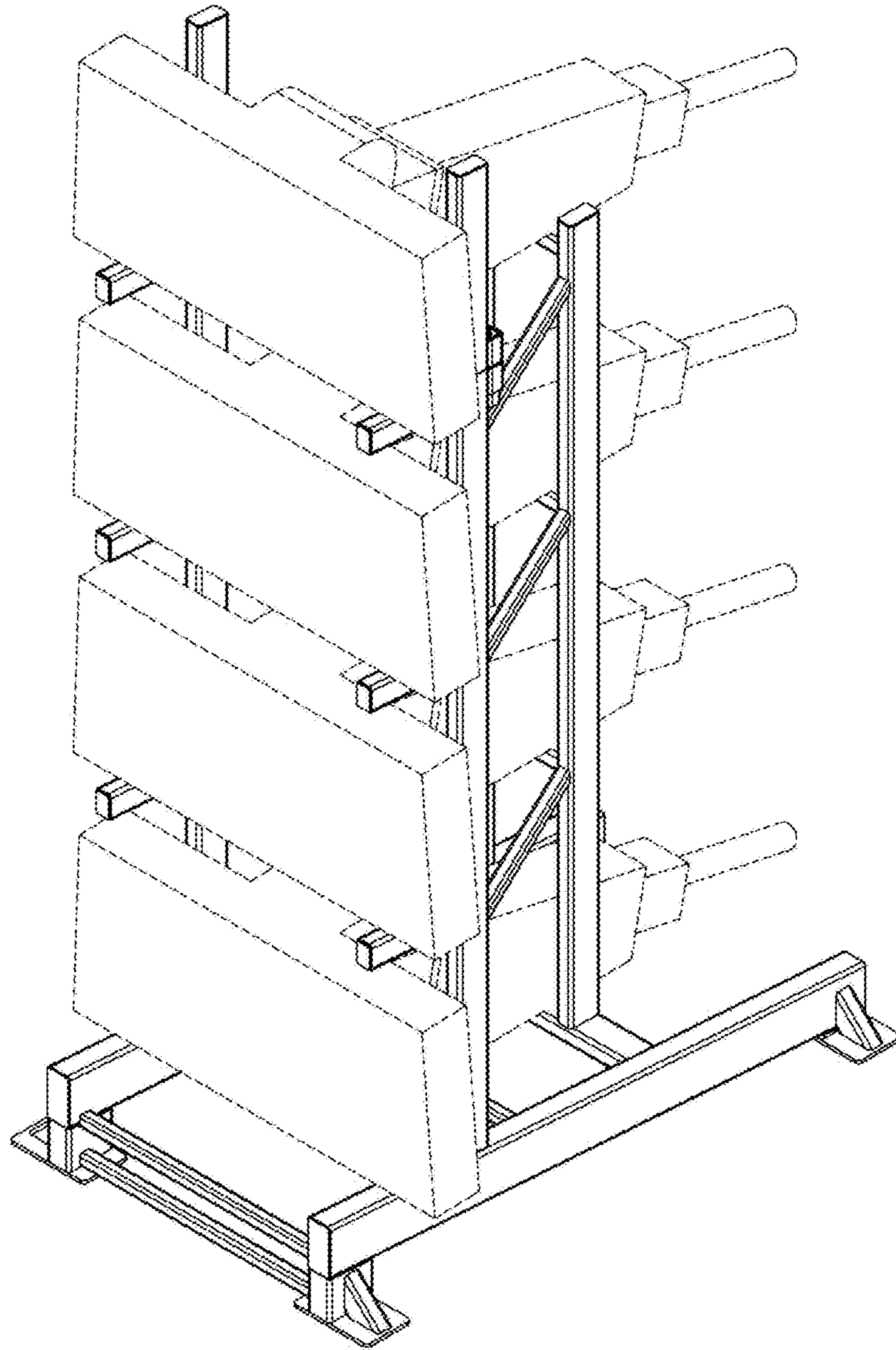

FIG. 2



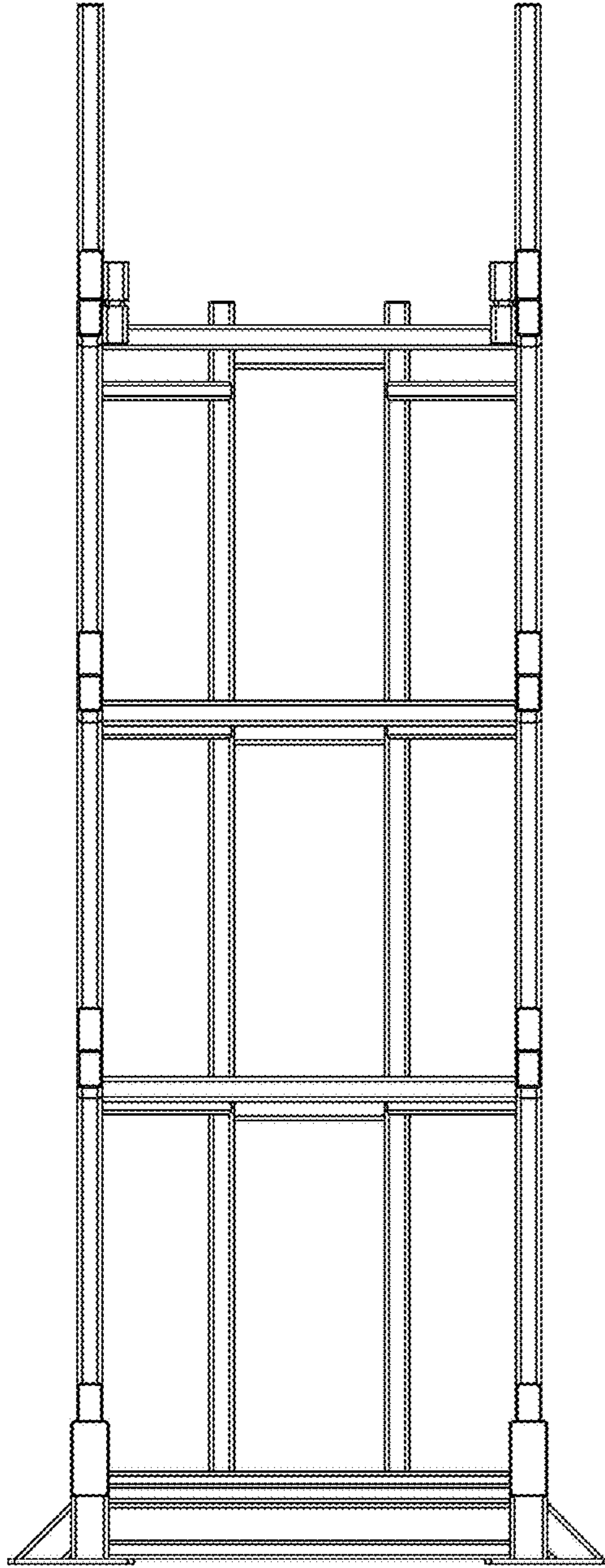

FIG. 3

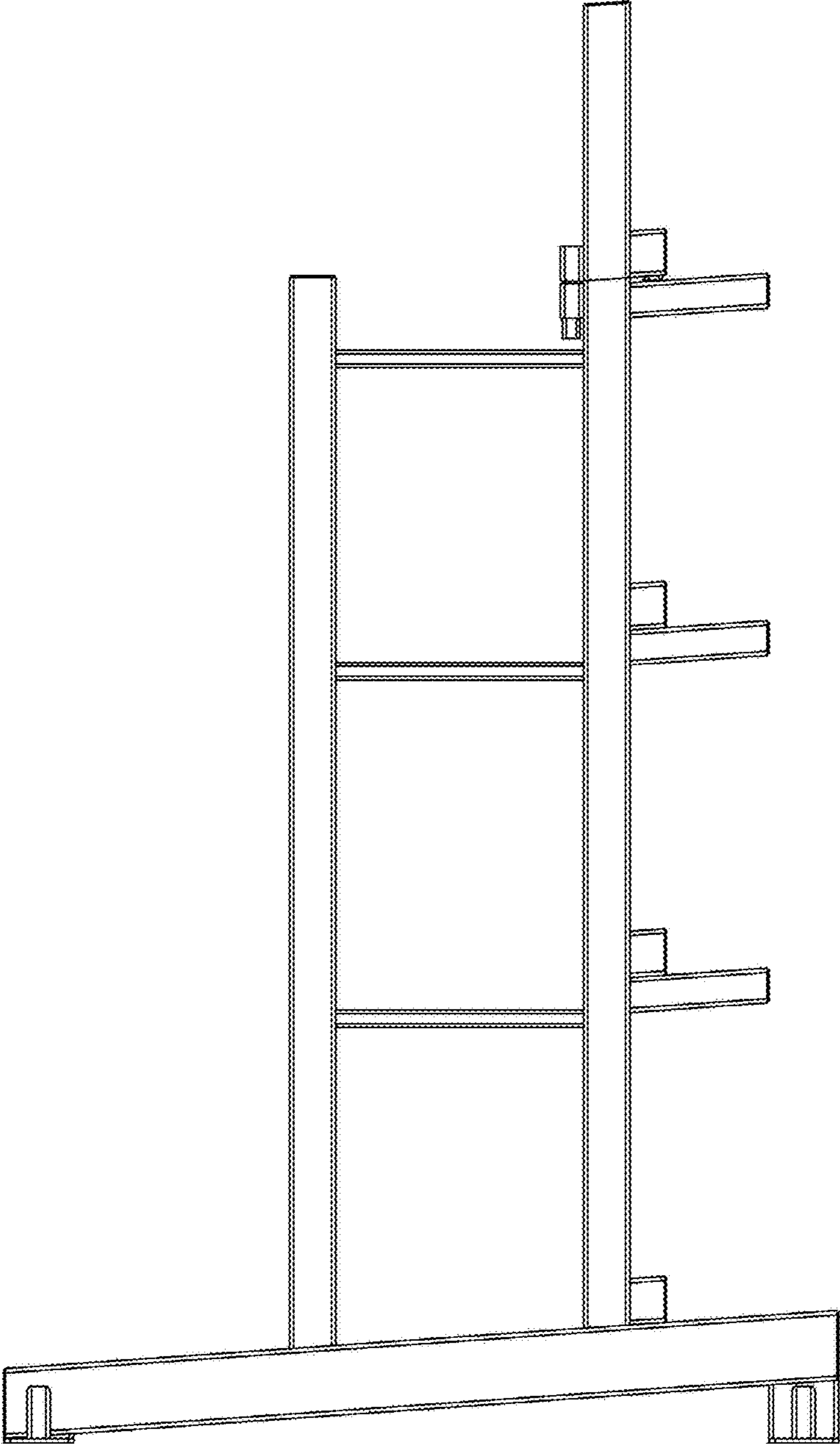

FIG. 4

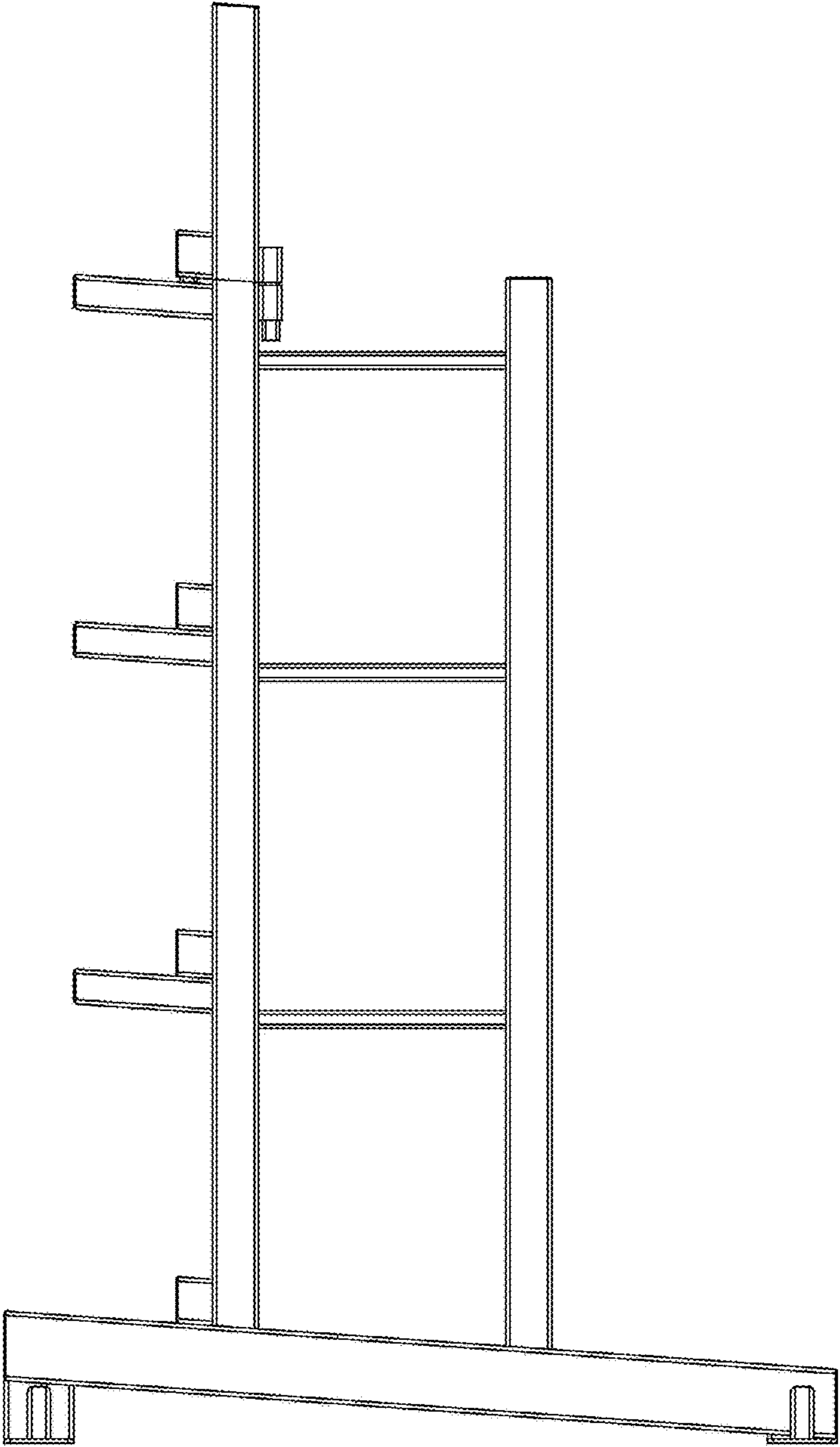

FIG. 5

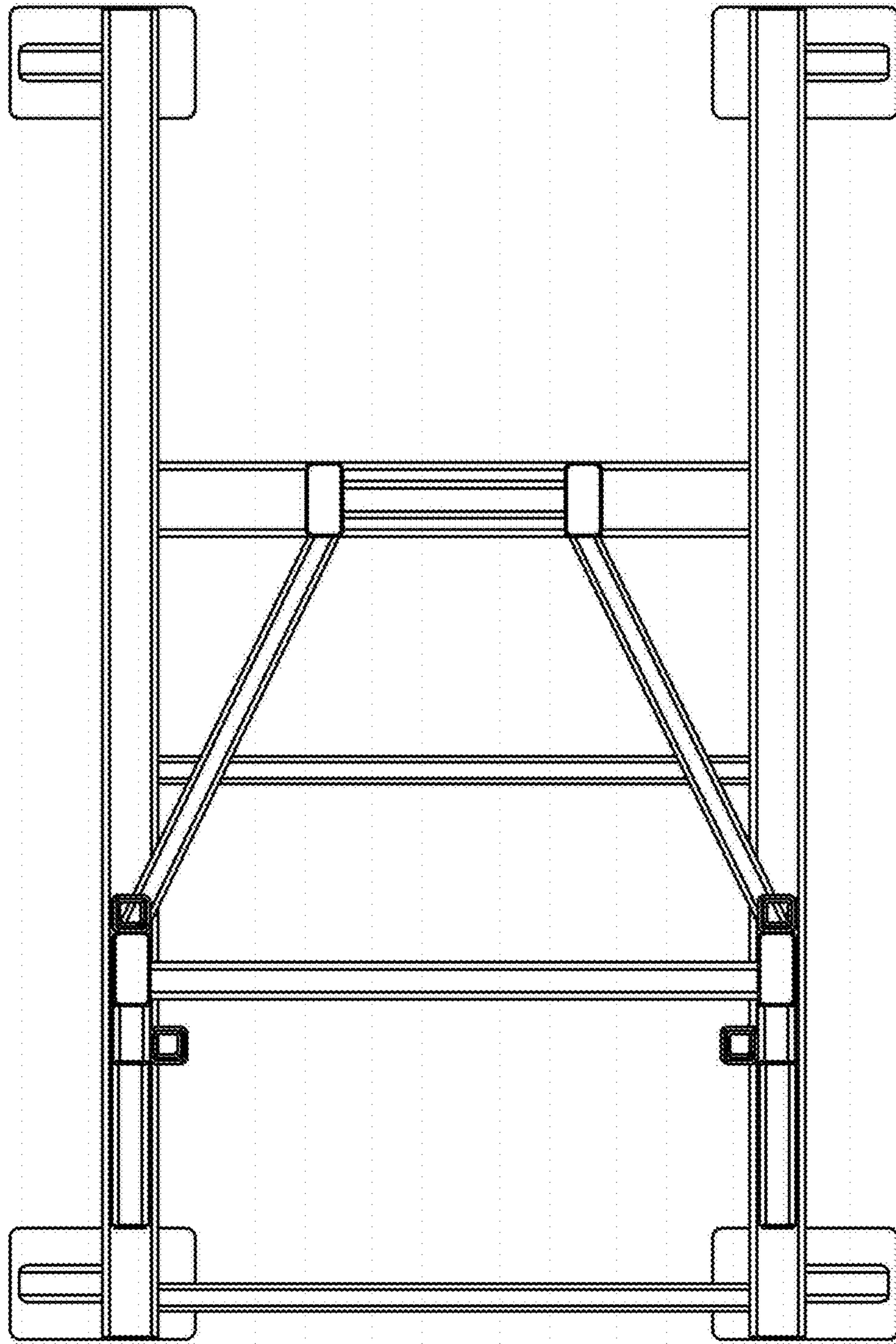

FIG. 6

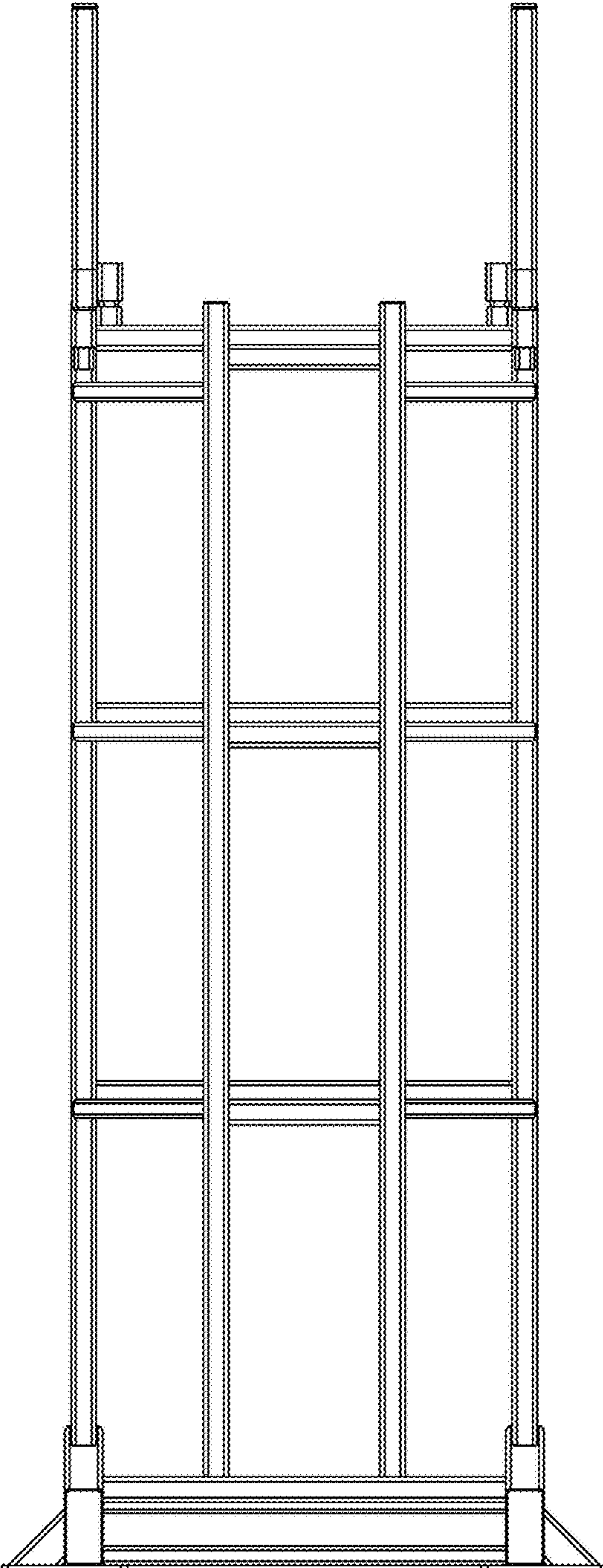

FIG. 7