



US00D910493S

(12) **United States Design Patent** (10) **Patent No.:** **US D910,493 S**  
**Langhals et al.** (45) **Date of Patent:** **\*\* Feb. 16, 2021**

(54) **AUTOMOBILE BODY**

(71) Applicants: **Taylor A. Langhals**, Waterford, MI (US); **Brian H. Nielander**, Royal Oak, MI (US); **Mark T. Allen**, Oxford, MI (US)

(72) Inventors: **Taylor A. Langhals**, Waterford, MI (US); **Brian H. Nielander**, Royal Oak, MI (US); **Mark T. Allen**, Oxford, MI (US)

(73) Assignee: **FCA US LLC**, Auburn Hills, MI (US)

(\*\*) Term: **15 Years**

(21) Appl. No.: **29/735,144**

(22) Filed: **May 19, 2020**

**Related U.S. Application Data**

(62) Division of application No. 29/670,328, filed on Nov. 15, 2018, now Pat. No. Des. 887,899.

(51) **LOC (13) Cl.** ..... **12-08**

(52) **U.S. Cl.**  
USPC ..... **D12/98**; D12/91

(58) **Field of Classification Search**  
USPC ..... D12/86, 90-92, 98; D21/424, 433, 434;  
296/181.1-181.5, 183.1  
CPC ..... B62D 25/00; B62D 25/06; B62D 33/00;  
B62D 35/00  
See application file for complete search history.

(56) **References Cited**

**U.S. PATENT DOCUMENTS**

D624,851 S \* 10/2010 Feng ..... D12/91  
D801,860 S \* 11/2017 Piscitelli ..... D12/91

D810,626 S \* 2/2018 Macey ..... D12/91  
D811,270 S \* 2/2018 Zhang ..... D12/91  
D825,385 S \* 8/2018 Ma ..... D12/91  
D827,495 S \* 9/2018 Piscitelli ..... D12/91  
D827,496 S \* 9/2018 Badstuebner ..... D12/91  
D828,223 S \* 9/2018 Piscitelli ..... D12/91  
D840,270 S \* 2/2019 Goodrich ..... D12/91  
D860,864 S \* 9/2019 Goodrich ..... D12/91  
D860,865 S \* 9/2019 Goodrich ..... D12/91  
D860,866 S \* 9/2019 Goodrich ..... D12/91  
D860,867 S \* 9/2019 Goodrich ..... D12/91  
D887,899 S \* 6/2020 Langhals ..... D12/91

\* cited by examiner

*Primary Examiner* — Melody N Brown

(74) *Attorney, Agent, or Firm* — Ralph E. Smith

(57) **CLAIM**

The ornamental design for an automobile body, as shown and described.

**DESCRIPTION**

FIG. 1 is a front perspective view of an automobile body showing our new design;  
FIG. 2 is a rear perspective view thereof;  
FIG. 3 is a top plan view thereof;  
FIG. 4 is a side view thereof;  
FIG. 5 is an opposite side view thereof;  
FIG. 6 is a front elevational view thereof; and,  
FIG. 7 is a rear elevational view thereof.  
It will be understood that the broken lines shown in the drawings illustrate portions of the automobile body that form no part of claimed design.

**1 Claim, 6 Drawing Sheets**

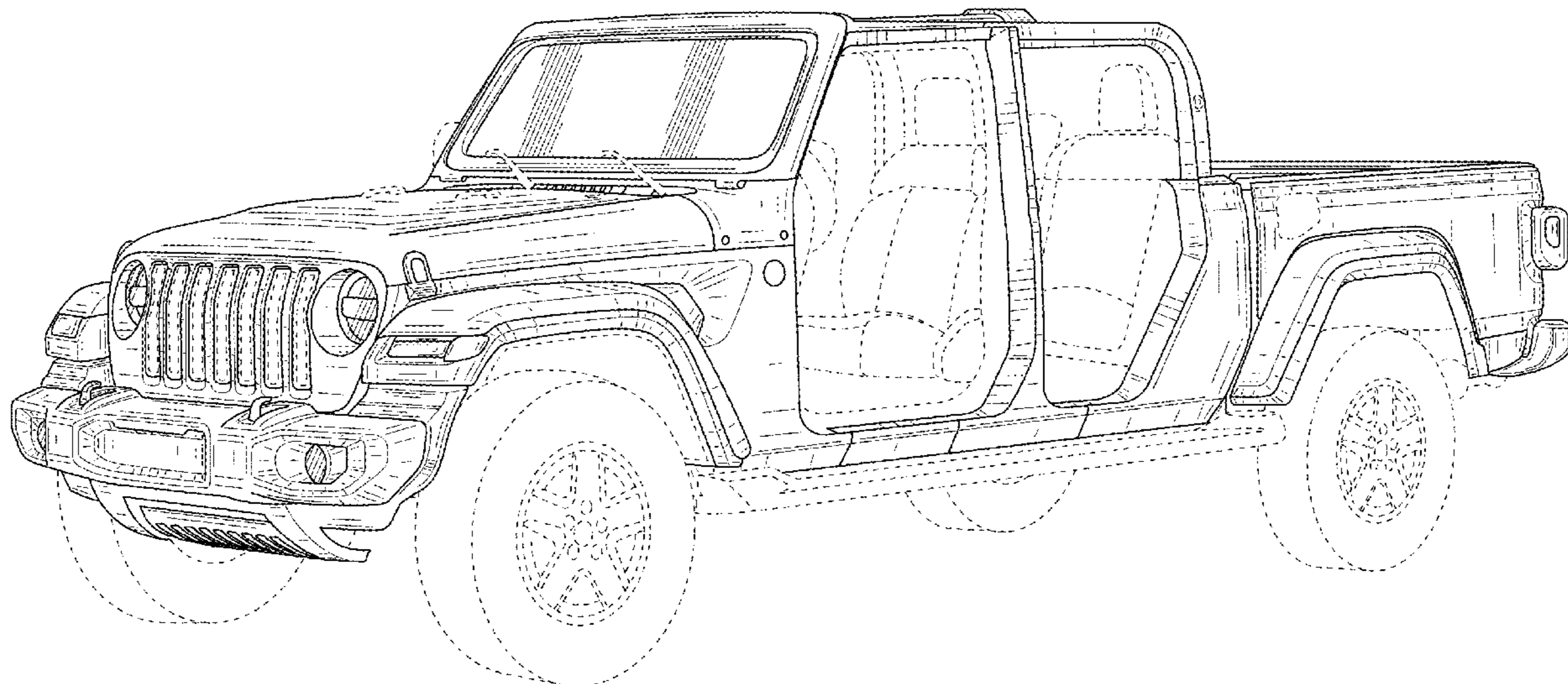

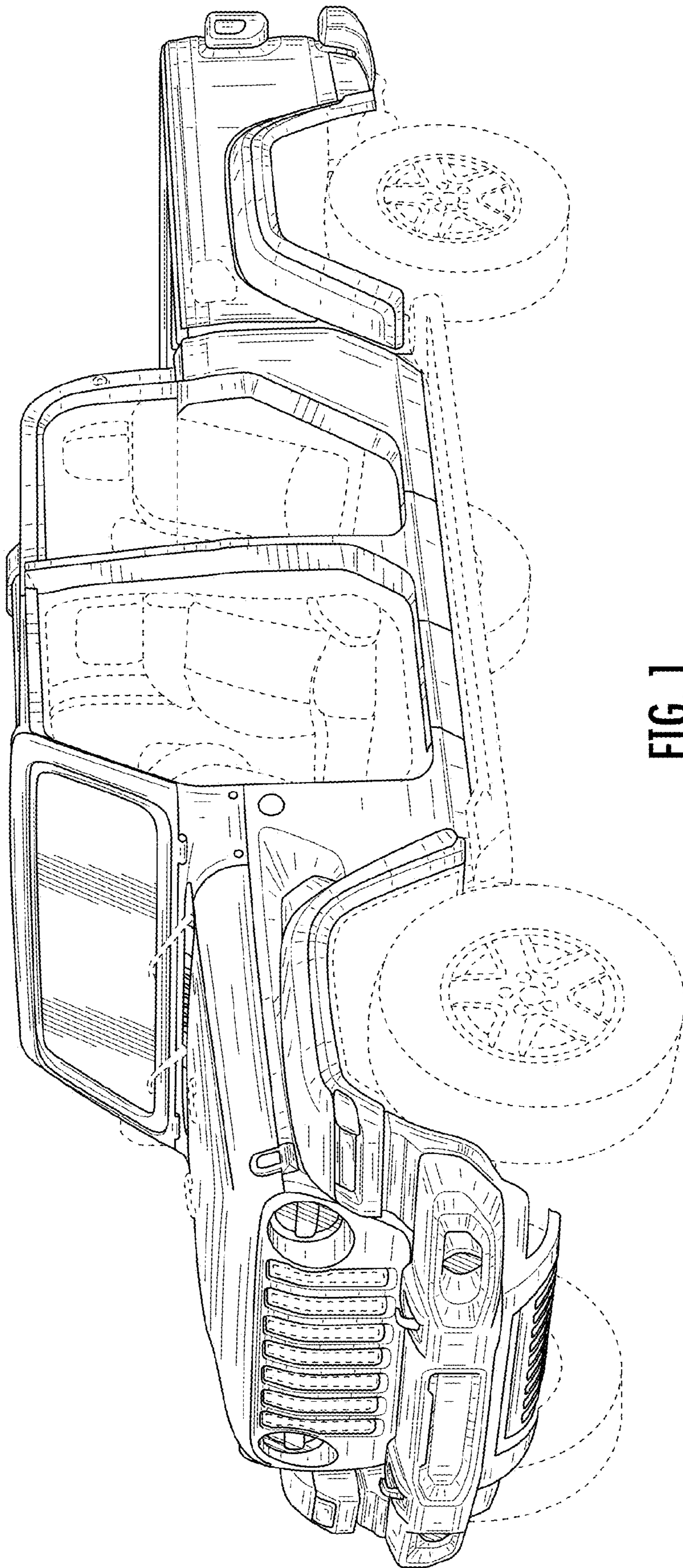

FIG. 1

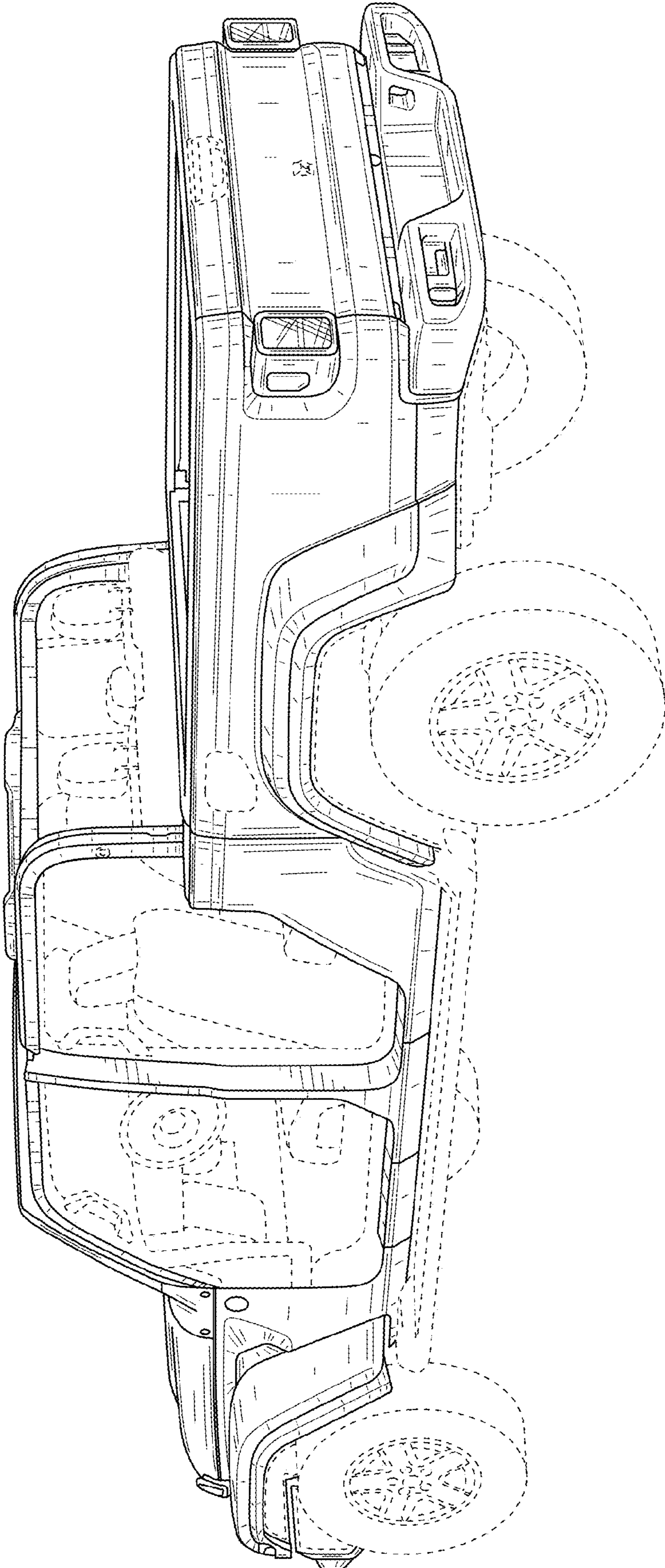

FIG. 2

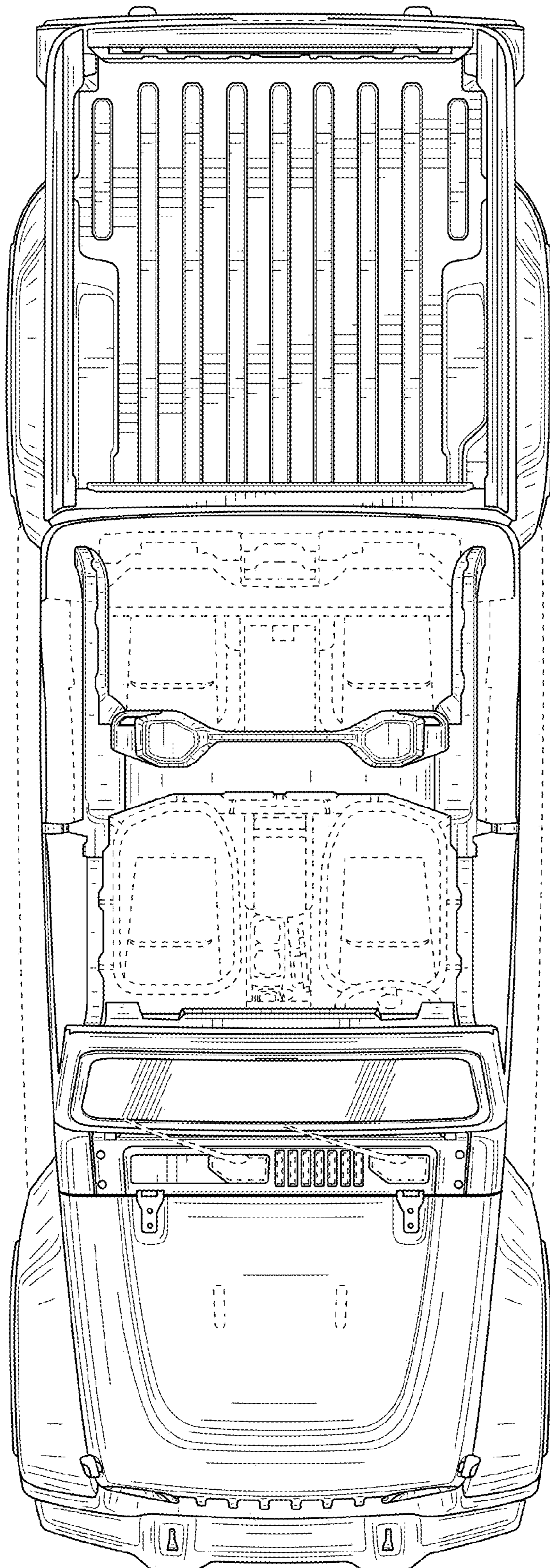

FIG. 3

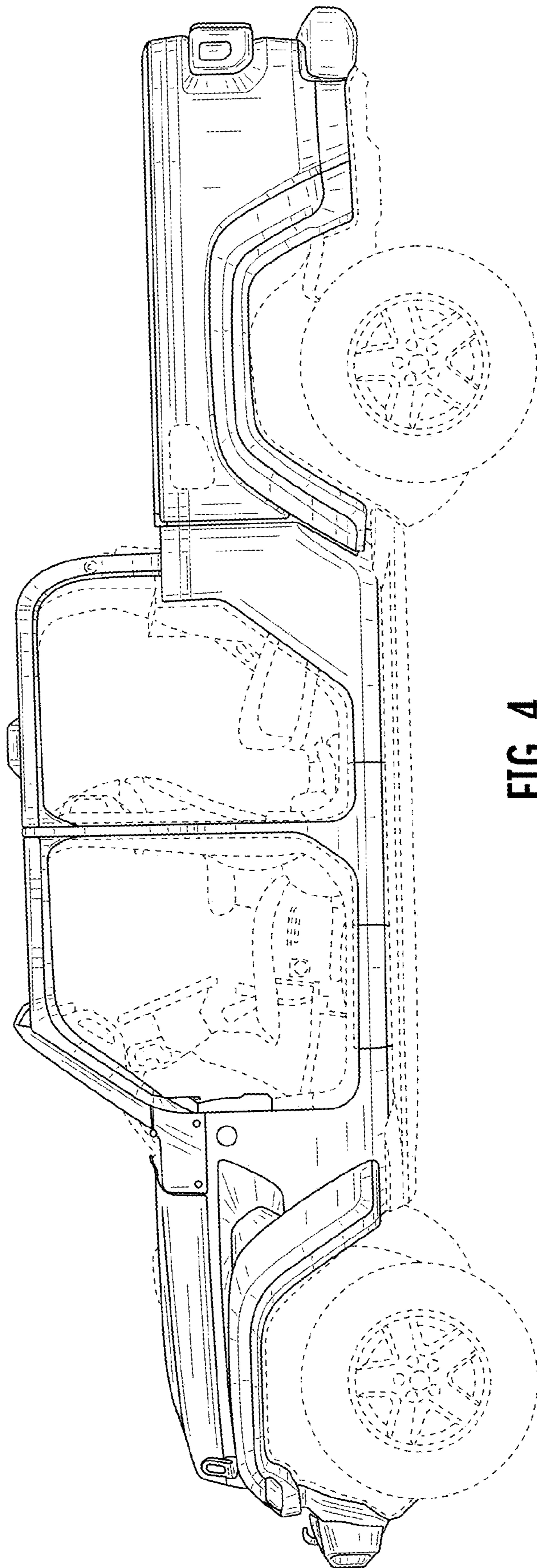

FIG. 4

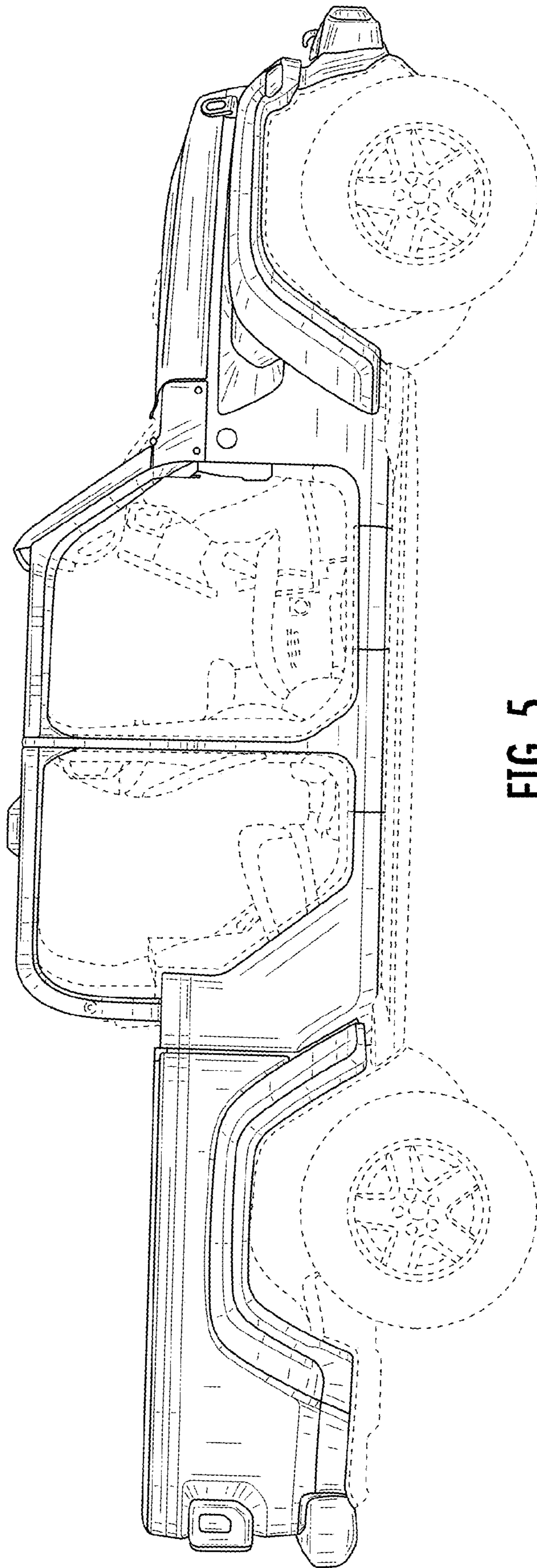

FIG. 5

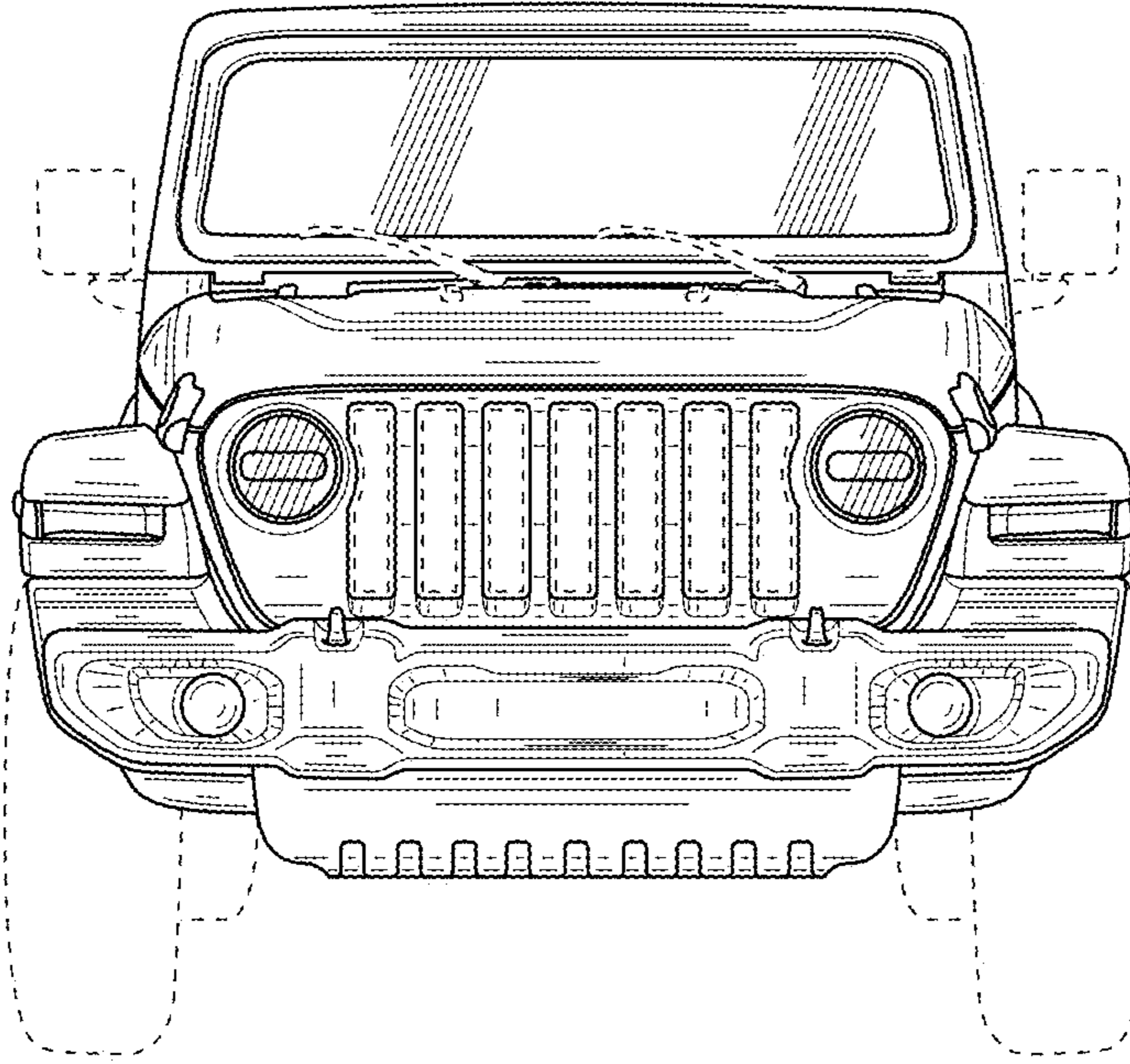

FIG. 6

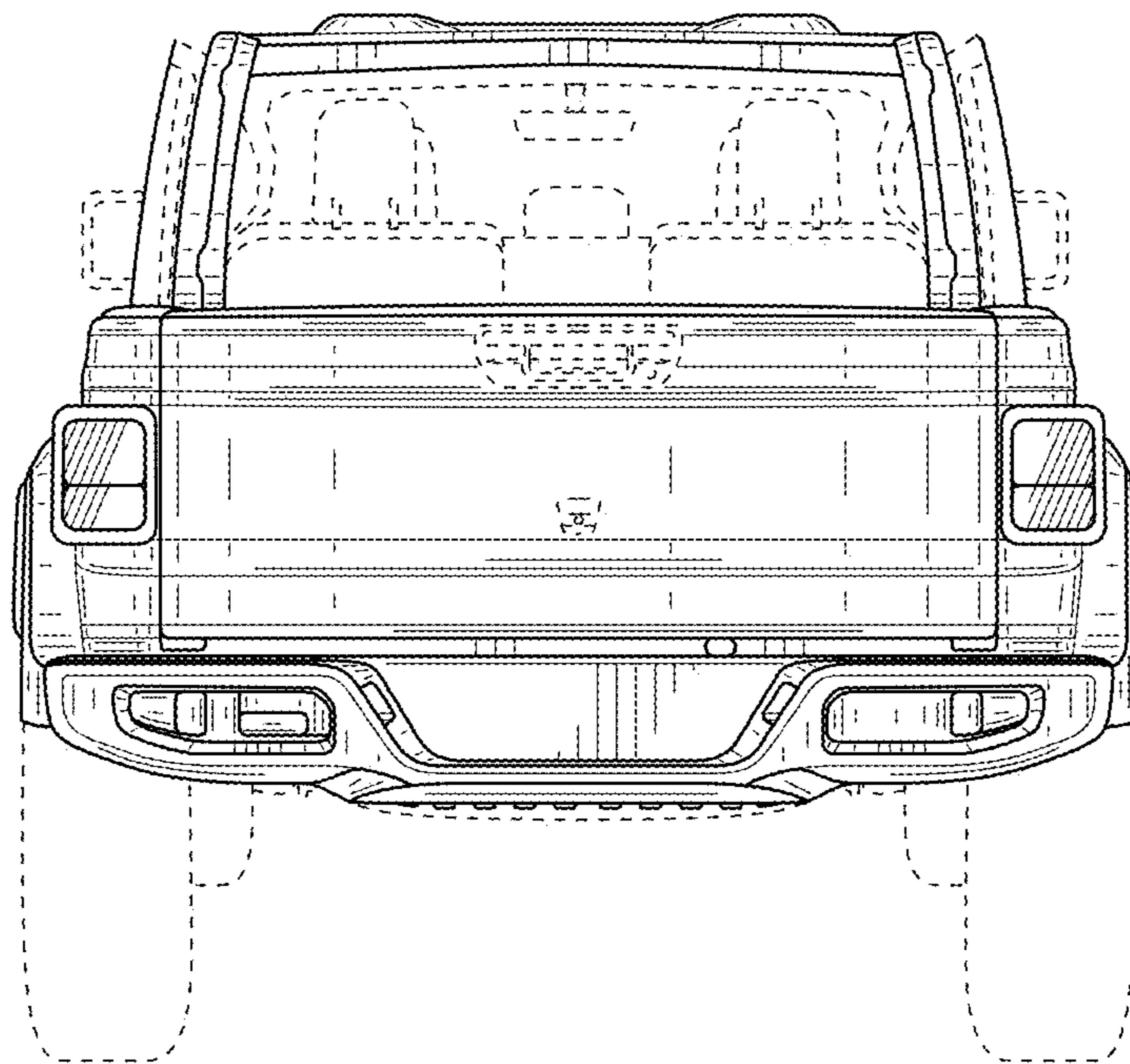

FIG. 7