



US00D910491S

(12) **United States Design Patent**  
**Manzoni**

(10) **Patent No.:** **US D910,491 S**  
(45) **Date of Patent:** **\*\* Feb. 16, 2021**

(54) **AUTOMOBILE**  
(71) Applicant: **FERRARI S.p.A.**, Modena (IT)  
(72) Inventor: **Flavio Manzoni**, Maranello (IT)  
(73) Assignee: **FERRARI S.p.A.**, Modena (IT)  
(\*\*) Term: **15 Years**  
(21) Appl. No.: **35/507,189**

D786,134 S \* 5/2017 Varga ..... D12/92  
D790,405 S \* 6/2017 Christensen ..... D12/92  
9,725,020 B2 \* 8/2017 Fainello ..... B60N 2/30  
D796,998 S \* 9/2017 Christensen ..... D12/92  
D797,606 S \* 9/2017 Oh ..... D12/92  
D808,302 S \* 1/2018 Oh ..... D12/92  
D809,971 S \* 2/2018 Lee ..... D12/92  
D809,972 S \* 2/2018 Fisker ..... D12/92  
D825,388 S \* 8/2018 Karras ..... D12/92  
D831,542 S \* 10/2018 Russo ..... D12/92  
D836,031 S \* 12/2018 Lim ..... D12/92  
D840,874 S \* 2/2019 Fisker ..... D12/92  
D845,174 S \* 4/2019 Iwao ..... D12/92

(Continued)

(22) Filed: **Jan. 24, 2019**

(80) **Hague Agreement Data**

Int. Filing Date: **Jan. 24, 2019**  
Int. Reg. No.: **DM/201297**  
Int. Reg. Date: **Jan. 24, 2019**  
Int. Reg. Pub. Date: **Aug. 2, 2019**

**OTHER PUBLICATIONS**

Nick D. "The Top-25 Greatest Convertible Ferrari's Ever Mad." Supercars.net., Aug. 9, 2018 [online], [retrieved on Oct. 23, 2020]. Retrieved from the Internet <URL: <https://www.supercars.net/blog/greatest-convertible-open-top-ferraris-ever-made/>>.\*

(Continued)

(30) **Foreign Application Priority Data**

Jul. 26, 2018 (EM) ..... 005515632

(51) **LOC (13) Cl.** ..... **12-08**

(52) **U.S. Cl.**  
USPC ..... **D12/92**

(58) **Field of Classification Search**  
USPC ..... D12/86, 90, 91, 92, 98; D21/424, 433, D21/434  
CPC ..... B62D 25/00; B62D 25/06; B62D 33/00; B62D 35/00; B62D 31/00  
See application file for complete search history.

*Primary Examiner* — Darlington Ly

(74) *Attorney, Agent, or Firm* — Cowan, Liebowitz & Latman, P.C.; Anastasia Zhadina

(57) **CLAIM**

The ornamental design for an automobile, as shown and described.

**DESCRIPTION**

**1.1** is a top, front and left side perspective view of an automobile showing my new design;  
**1.2** is a top, rear, and right side perspective view thereof;  
**1.3** is a front elevation view thereof;  
**1.4** is a rear elevation view thereof;  
**1.5** is a left side elevation view thereof;  
**1.6** is a top plan view thereof; and  
**1.7** is a bottom plan view thereof.  
Portions of the automobile shown in broken lines are not part of the claimed design.

**1 Claim, 7 Drawing Sheets**

(56) **References Cited**

**U.S. PATENT DOCUMENTS**

D680,030 S \* 4/2013 Rodriguez ..... D12/92  
D703,585 S \* 4/2014 Scheinhutte ..... D12/92  
D710,260 S \* 8/2014 Villarreal ..... D12/92  
9,073,410 B2 \* 7/2015 Bruant ..... B60J 7/028  
D738,259 S \* 9/2015 Ohnuma ..... D12/92  
D763,737 S \* 8/2016 Varga ..... D12/92

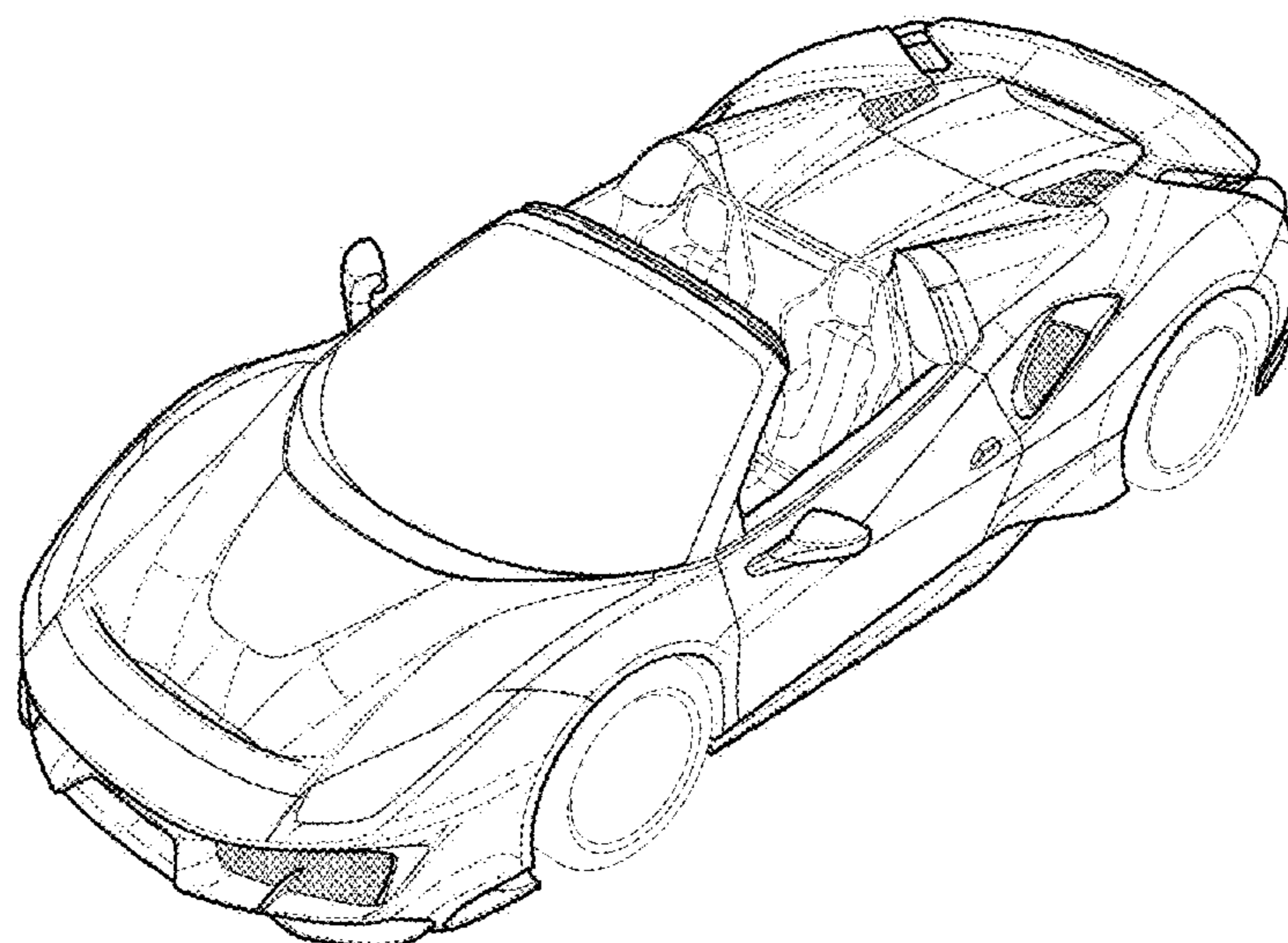

(56)

**References Cited**

U.S. PATENT DOCUMENTS

D847,028 S \* 4/2019 Loeb ..... D12/92

OTHER PUBLICATIONS

Clifford Atiyeh. "2019 Ferrari 488 Pista Spider Offers 710 HP without a Roof." Car and Driver., Sep. 4, 2018 [online], [retrieved on Oct. 23, 2020]. Retrieved from the Internet <URL: <https://www.caranddriver.com/news/a22865625/2019-ferrari-488-pista-spider-supercar-photos-info/>>.\*

Peter Jones. "Which Ferraris Are Convertible? 6 Models (With Pictures)." Motor and Wheels., Dec. 30, 2019 [online], [retrieved on Oct. 23, 2020]. Retrieved from the Internet <URL: <https://motorandwheels.com/which-ferraris-are-convertible/>>.\*

Peter Valdes-Dapena. "I hate to say it, but Ferrari's new convertible is worth every penny." CNN Business., Sep. 19, 2019 [online], [retrieved on Oct. 23, 2020]. Retrieved from the Internet <URL: <https://www.cnn.com/2020/09/19/success/ferrari-f8-spider-convertible-review/index.html>>.\*

\* cited by examiner

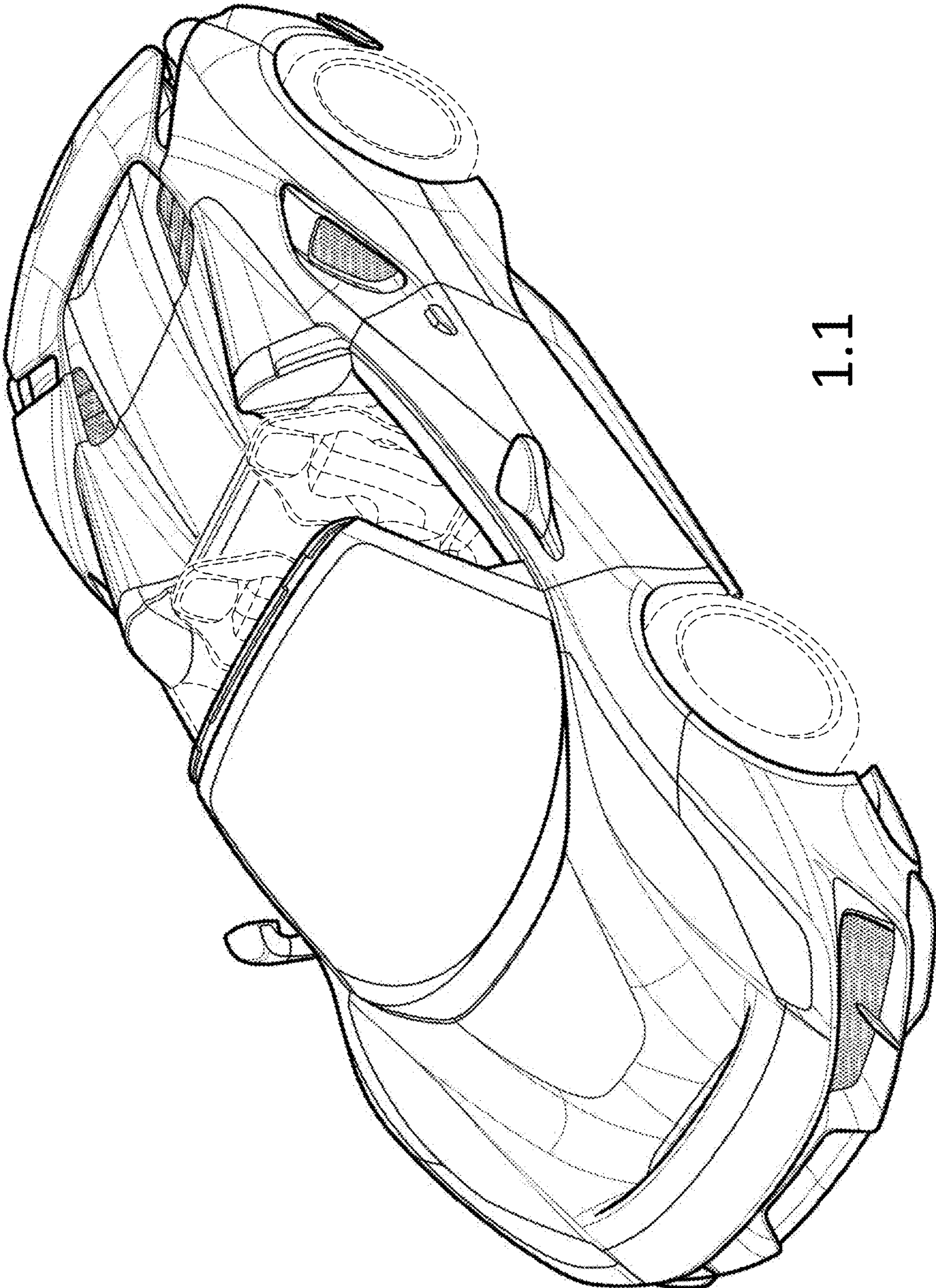

1.1

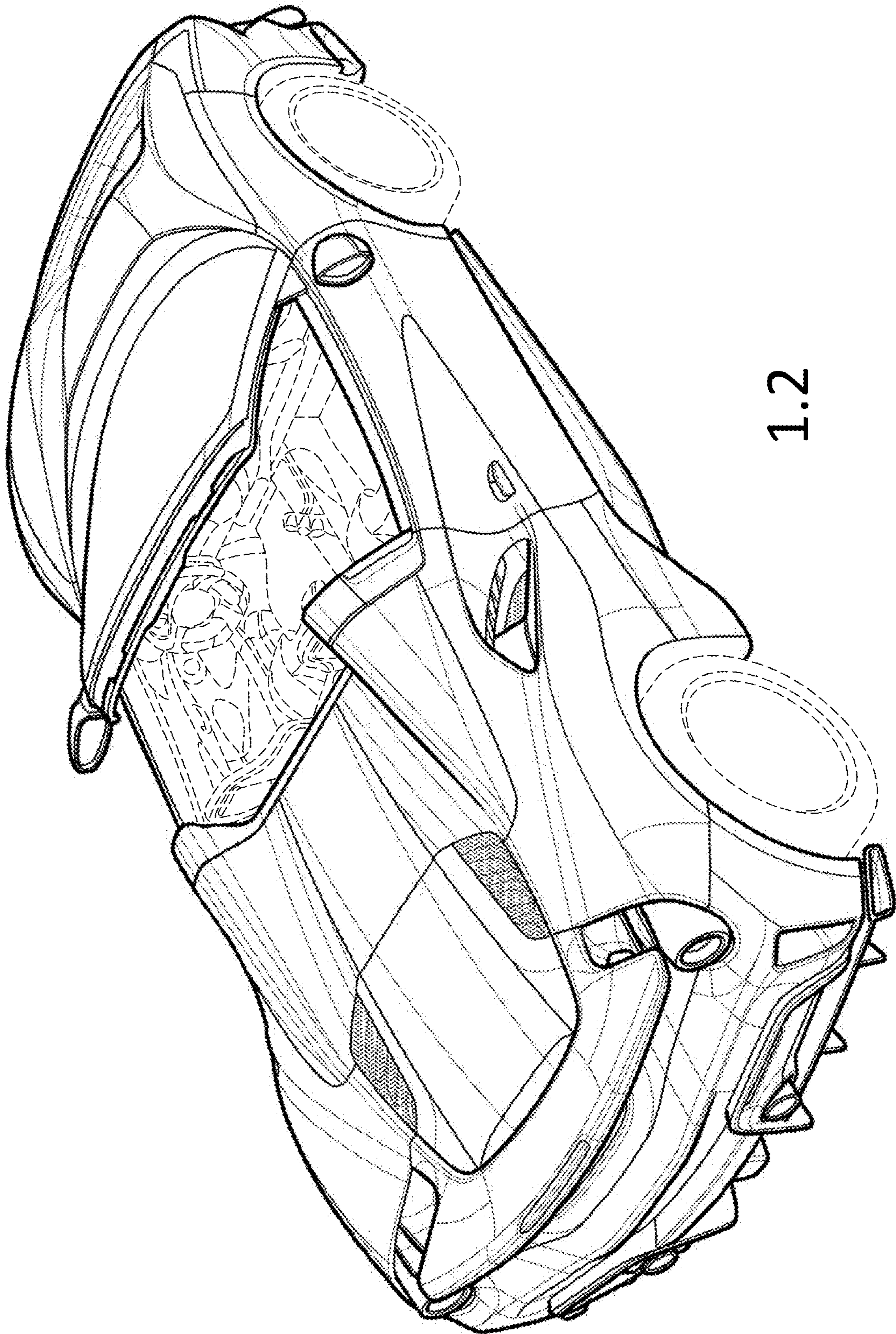

1.2

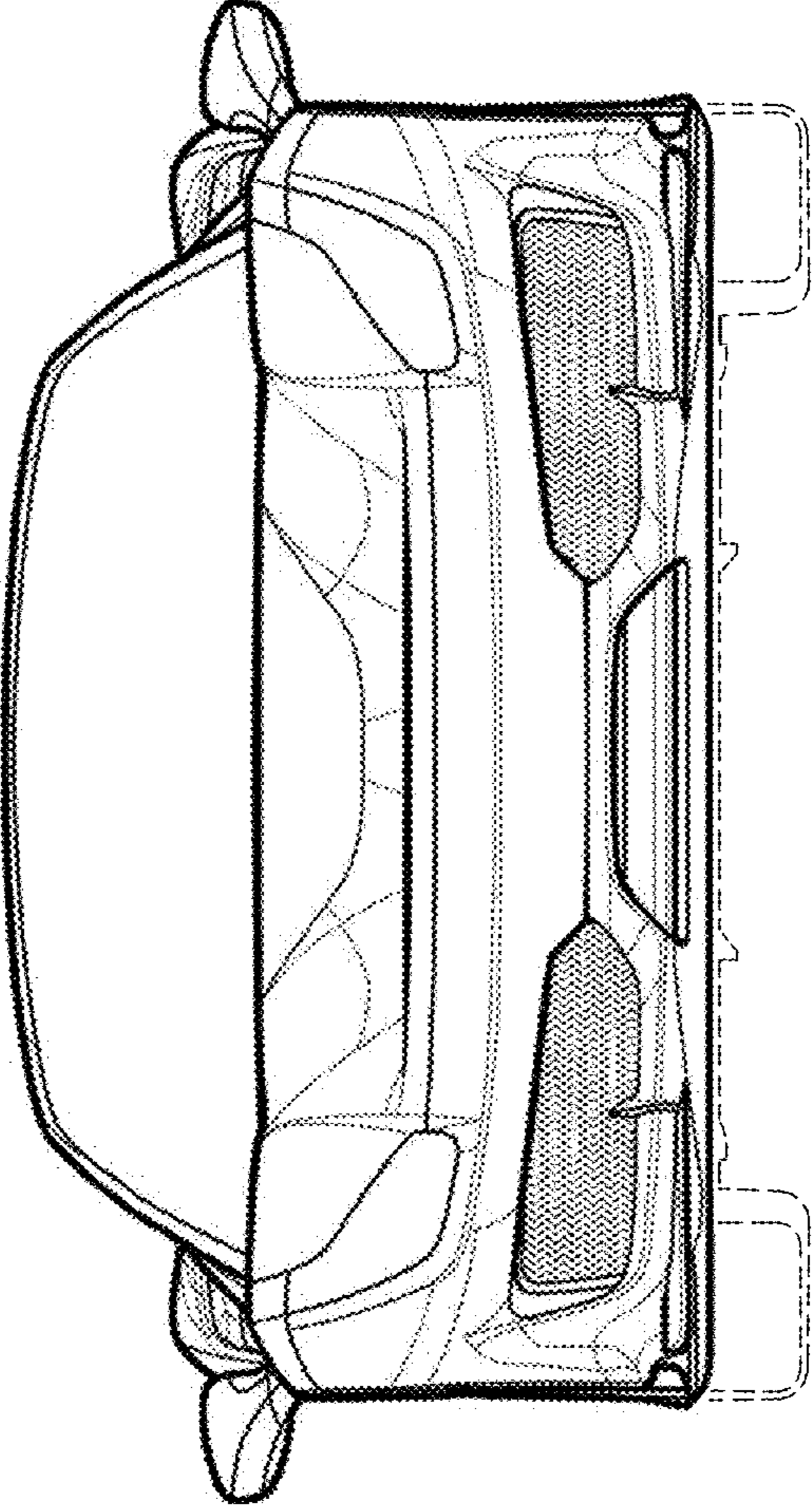

1.3

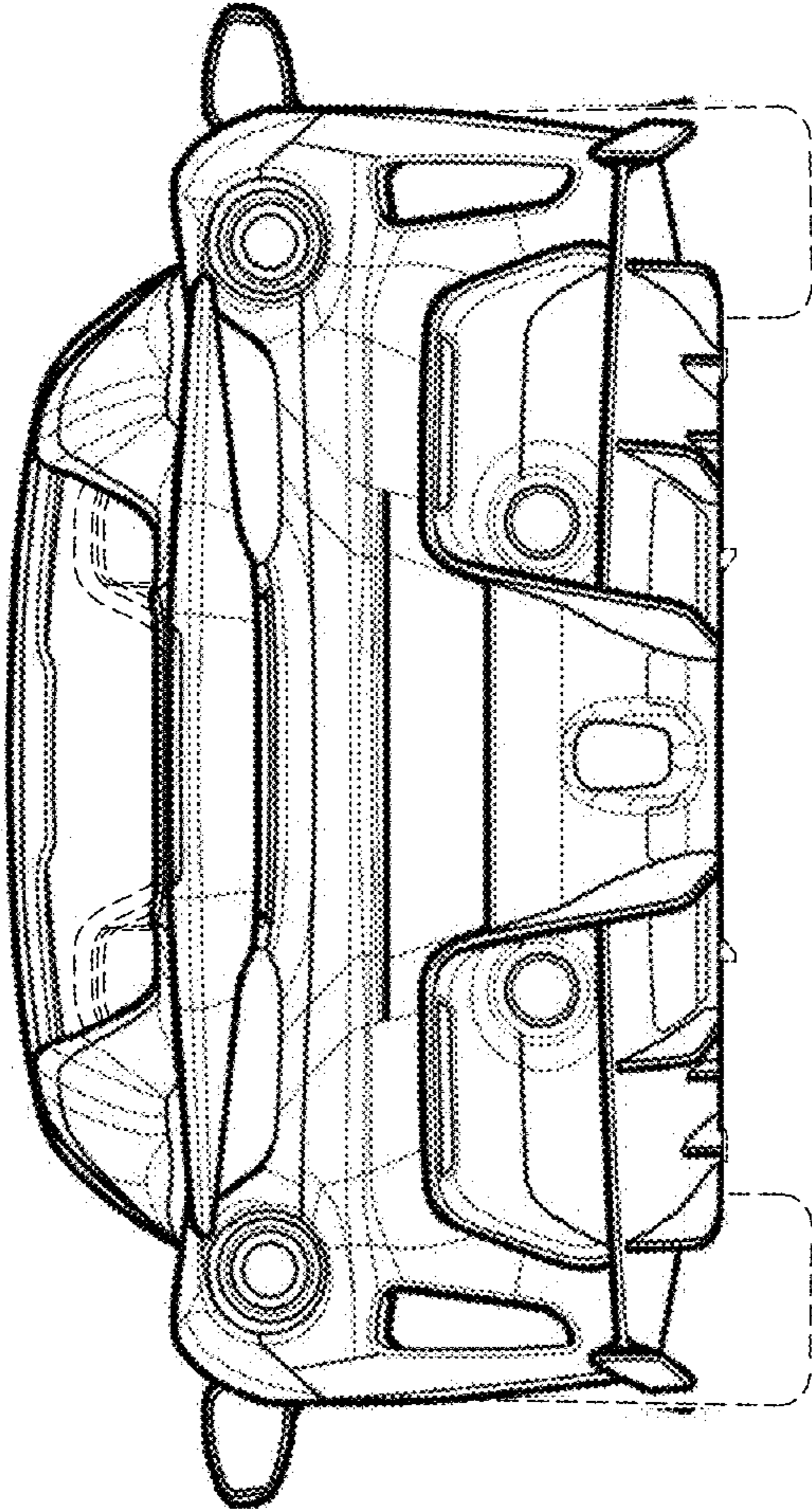

1.4

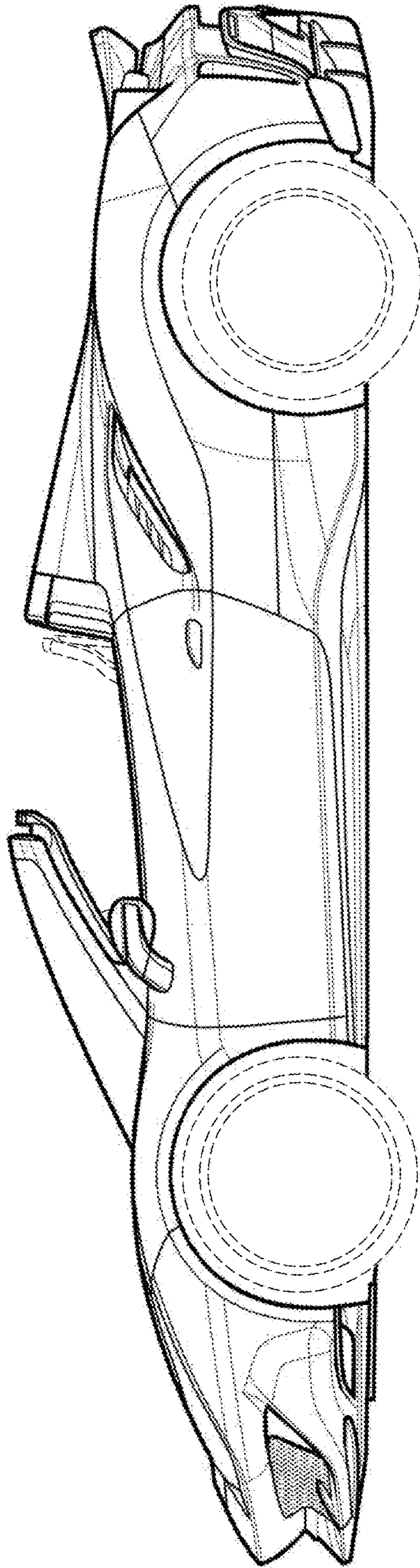

1.5

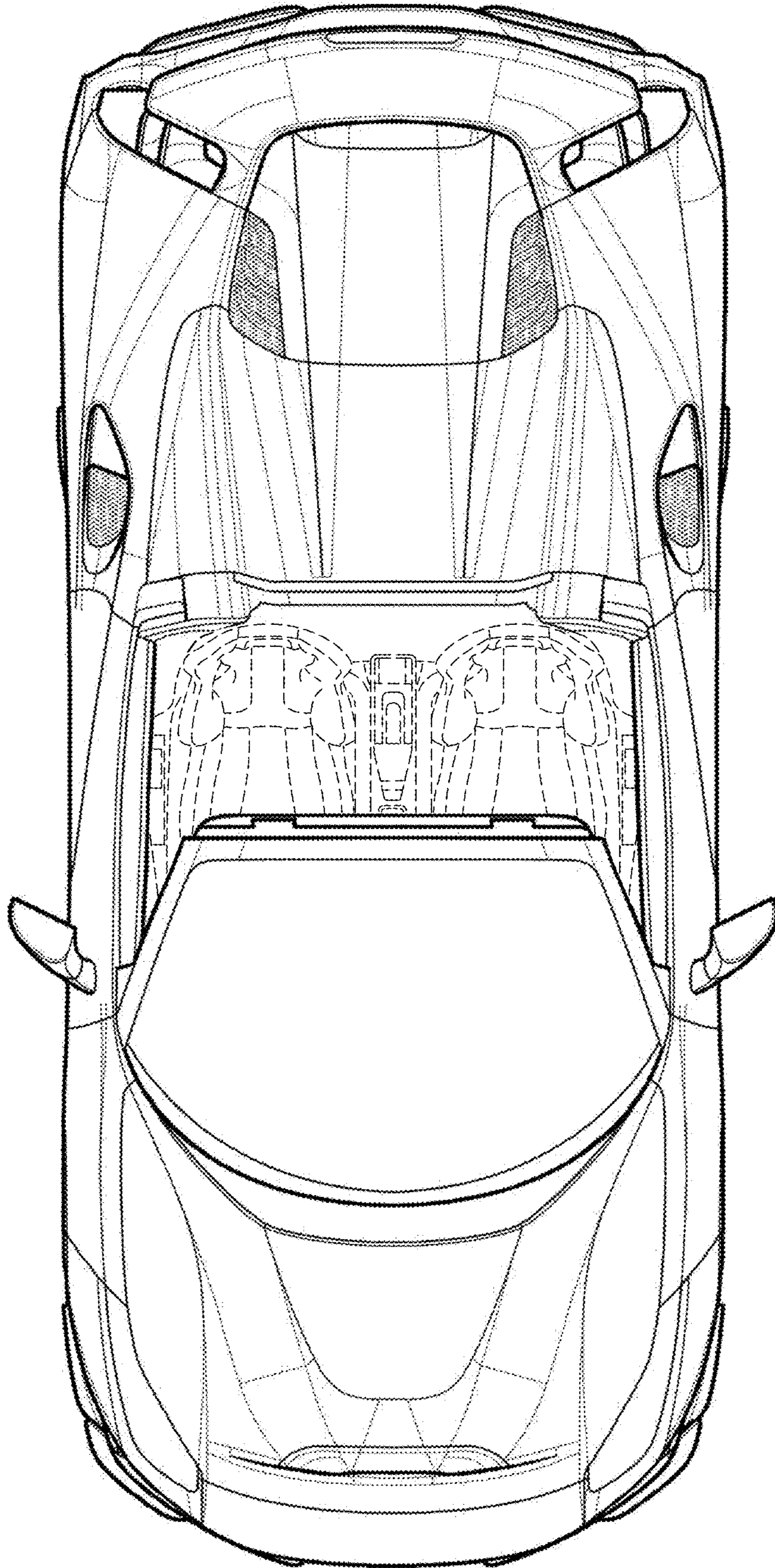

1.6



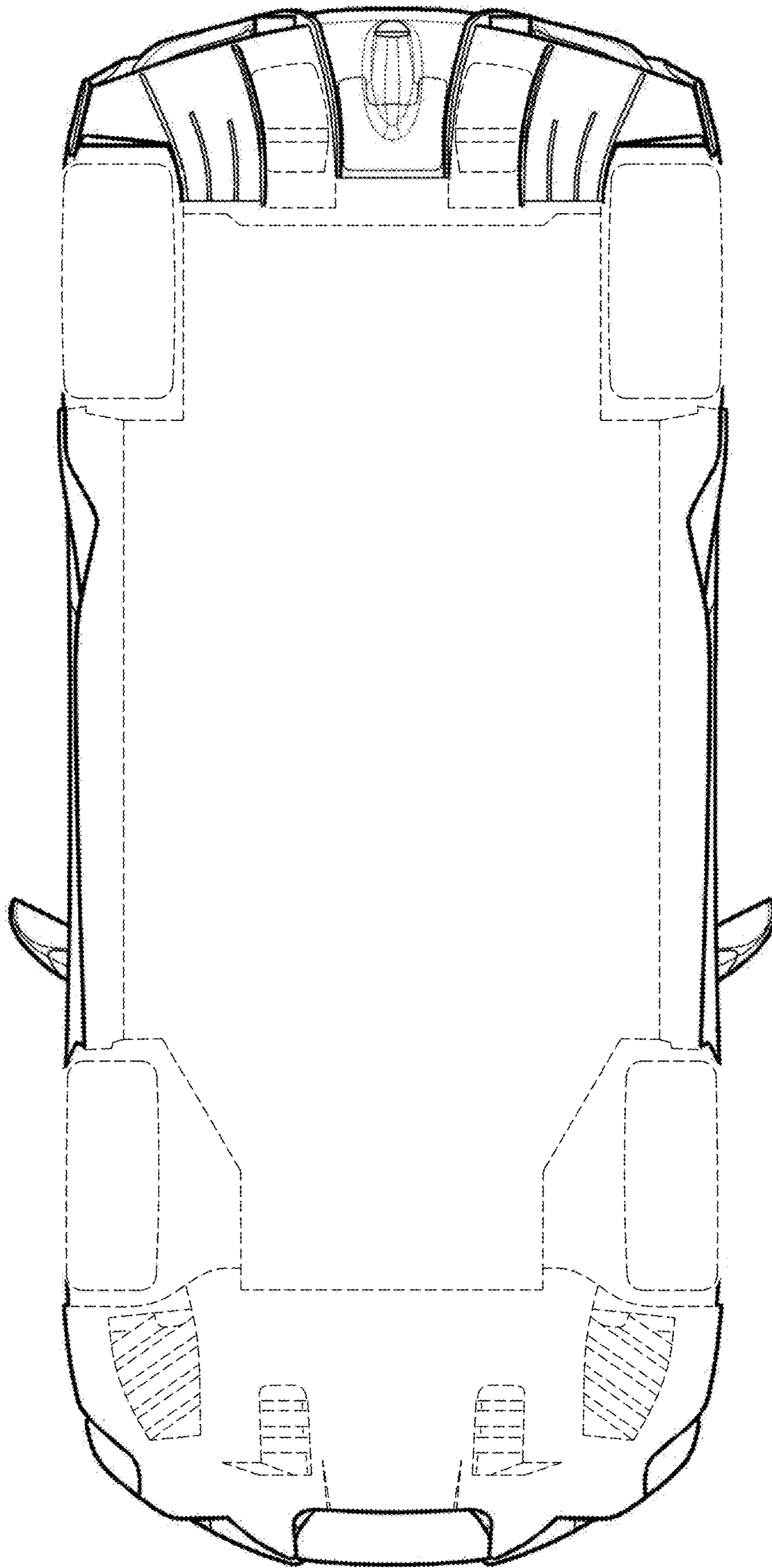

1.7