



US00D910086S

(12) **United States Design Patent** (10) **Patent No.:** **US D910,086 S**  
**Keen et al.** (45) **Date of Patent:** **\*\* Feb. 9, 2021**

(54) **WORK MACHINE**

(56)

**References Cited**

- (71) Applicant: **DEERE & COMPANY**, Moline, IL (US)
- (72) Inventors: **Eric Keen**, Manhattan, KS (US); **Brian Huenink**, Cedar Grove, WI (US); **Richard N. Knowles**, Waterloo, IA (US); **Thomas C Boe**, Cedar Falls, IA (US); **Felix Nagelin**, Malibu, CA (US); **Thorsten Hagner**, Ilvesheim (DE); **Michael D Kollath**, Concordia, IA (US); **Charles N Warren**, Waterloo, IA (US); **Daniel J DeBoer**, Waucoma, IA (US); **William Clayton Martin**, Stillwater, OK (US); **John W. Krieger**, Westlake Village, CA (US); **Volker Durre**, Rancho Palos Verdes, CA (US); **Sebastian Himpel**, Mannheim (DE)
- (73) Assignee: **DEERE & COMPANY**, Moline, IL (US)
- (\*\*) Term: **15 Years**
- (21) Appl. No.: **29/671,770**
- (22) Filed: **Nov. 29, 2018**
- (30) **Foreign Application Priority Data**
- May 30, 2018 (EP) ..... 005288503  
 May 30, 2018 (EP) ..... 005289014
- (51) **LOC (13) Cl.** ..... **12-09**
- (52) **U.S. Cl.**  
 USPC ..... **D15/23; D15/33**
- (58) **Field of Classification Search**  
 USPC ..... D15/10, 11, 13-17, 28, 22-26, 30, 31, D15/33; D12/173; 56/13.3, 13.4, 15.8, 56/15.9, 320.1; 180/89.1, 89.12, 900, 180/69.2, 68.1, 69.1  
 CPC ..... B62D 49/00-085; B62D 25/10; B62D 25/00; B60R 19/52; B60R 21/38  
 See application file for complete search history.

U.S. PATENT DOCUMENTS

2,216,366 A	10/1940	Greene	
D283,135 S	3/1986	Funabashi et al.	
D288,206 S	2/1987	Moscovitch	
D294,223 S	2/1988	Gollon et al.	
D297,142 S	8/1988	Funabashi et al.	
D304,589 S	11/1989	Lanphere et al.	
D311,543 S	10/1990	Hardzinski et al.	
D327,276 S	6/1992	Sorensen	
D348,678 S	7/1994	Budde	
D353,704 S	12/1994	Bhambra	
D398,616 S	9/1998	Kwak et al.	
D416,266 S	11/1999	Del Torchio	
D419,164 S	1/2000	Heiler et al.	
D424,580 S	5/2000	Moehle et al.	
6,058,637 A	5/2000	Duncan	
D430,579 S	9/2000	Westendorf et al.	
D443,852 S	6/2001	Huang	
D447,153 S	8/2001	Hornung	
D447,754 S	9/2001	Smith et al.	
D448,037 S	9/2001	Westimayer et al.	
D451,106 S	11/2001	Crookes et al.	
D451,870 S	12/2001	Hurayt	
D458,944 S	6/2002	Crookes et al.	
D470,811 S	2/2003	Carroll	
D471,142 S	3/2003	Carroll	
D471,143 S	3/2003	Carroll	
6,595,550 B1	7/2003	Meazzi	
D483,383 S	12/2003	Crookes et al.	
D484,080 S	12/2003	Yamamoto et al.	
D492,922 S	7/2004	Numata	
D495,344 S	8/2004	Farlow et al.	
D495,345 S	8/2004	Farlow et al.	
D496,314 S	9/2004	Perfetti et al.	
D499,680 S	12/2004	Lucas	
D512,079 S	11/2005	Farlow et al.	
D512,445 S	12/2005	Farlow et al.	
D517,121 S	3/2006	Li	
D520,527 S	5/2006	Crookes et al.	
D521,532 S *	5/2006	Higashikawa	D15/31
D522,425 S	6/2006	Beigel et al.	
D528,134 S	9/2006	Vandendriessche et al.	
D531,646 S	11/2006	McCarren, Jr. et al.	
D531,647 S	11/2006	Stender et al.	
D533,569 S	12/2006	Mursch	
D533,882 S *	12/2006	Higashikawa	D15/31
D541,825 S	5/2007	Pettersson	
D541,826 S	5/2007	Brush et al.	
D546,254 S	7/2007	Teng	
D546,255 S	7/2007	Teng	

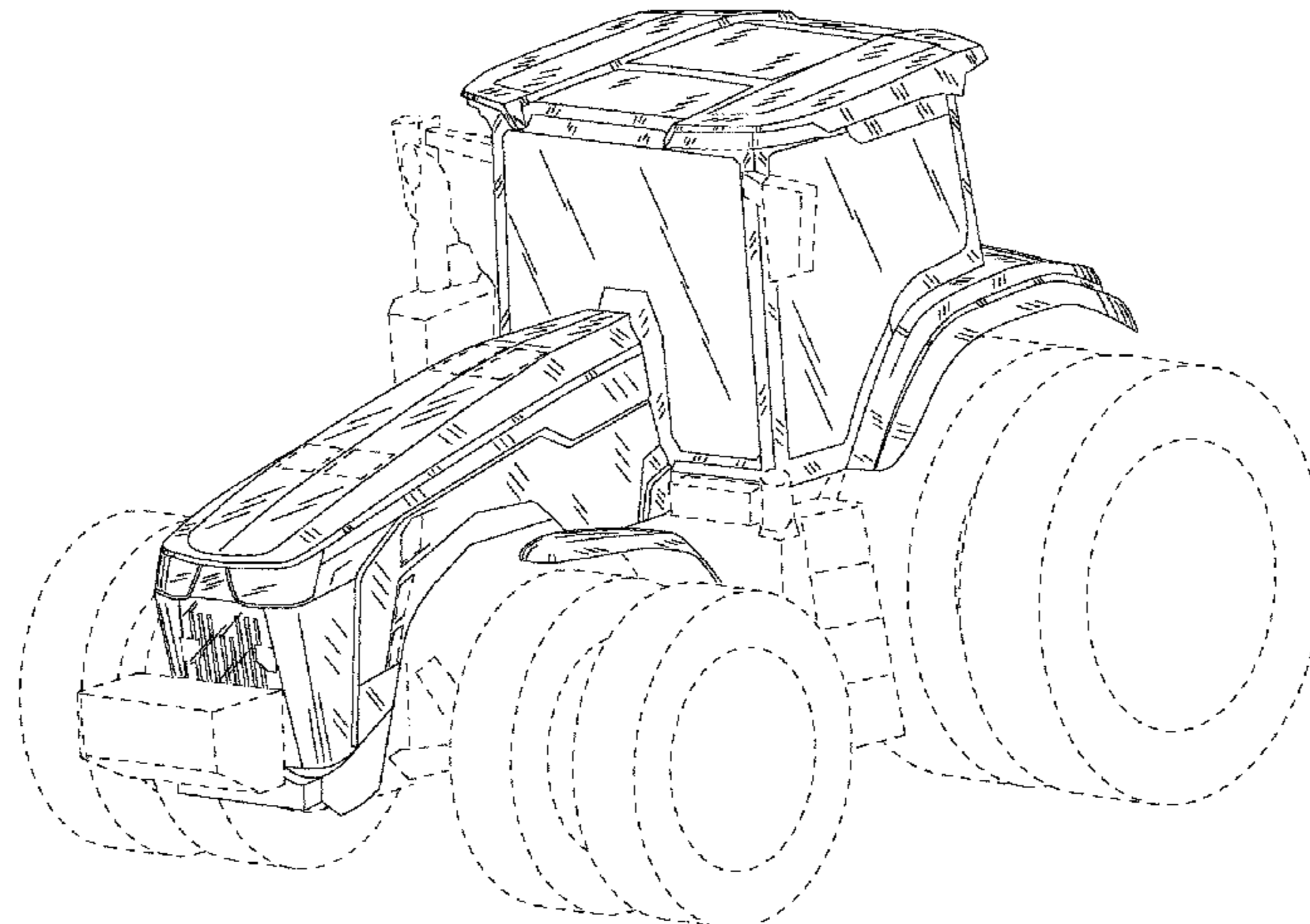

# US D910,086 S

D553,159 S	10/2007	Higashikawa et al.	D663,753 S	7/2012	Hickman et al.
D553,161 S	10/2007	Matsumoto	D665,428 S	8/2012	Hickman et al.
D553,268 S	10/2007	Pfeiffer	D665,429 S	8/2012	Hickman et al.
D554,669 S	11/2007	Crookes et al.	D667,851 S	9/2012	Warr
D556,789 S	12/2007	Kitayama et al.	D668,693 S	10/2012	Ringer
D557,714 S	12/2007	Higashikawa et al.	D668,695 S	* 10/2012	Ringer ..... D15/31
D558,797 S	1/2008	Yamamoto et al.	D670,744 S	11/2012	Ewringmann
D560,693 S	1/2008	Moen et al.	D670,745 S	11/2012	Warr
D561,205 S	2/2008	Pettersson	D671,566 S	11/2012	Fang et al.
D565,211 S	3/2008	Haller et al.	D673,489 S	1/2013	Hanson et al.
D567,257 S	4/2008	Wilkens	D674,410 S	1/2013	Blind et al.
D568,905 S	5/2008	Heusinger et al.	D674,820 S	1/2013	Budde
D570,015 S	5/2008	Hsu	D674,821 S	1/2013	Budde
D570,378 S	6/2008	Heusinger et al.	D674,938 S	1/2013	Lai
D571,378 S	6/2008	Bernard et al.	D675,233 S	* 1/2013	Kushita ..... D15/31
D579,028 S	10/2008	VanDeVeer et al.	D676,463 S	2/2013	Ewringmann et al.
D581,467 S	11/2008	Winningham et al.	D676,466 S	* 2/2013	Ewringmann ..... D15/20
D581,955 S	12/2008	Matsumoto et al.	D676,786 S	2/2013	Werner et al.
D591,437 S	4/2009	Saridakis et al.	D682,323 S	5/2013	Ryan et al.
D591,777 S	* 5/2009	Kokitkar ..... D15/31	D682,324 S	5/2013	Ryan et al.
D593,233 S	5/2009	Bai et al.	D688,176 S	8/2013	Campbell et al.
D594,797 S	6/2009	Lee	D690,635 S	10/2013	Hovind et al.
D594,908 S	6/2009	Sauter	D697,536 S	* 1/2014	Nuebel ..... D15/23
D595,778 S	7/2009	Sauter	D699,765 S	2/2014	Tentinger et al.
D595,779 S	7/2009	Sauter	D699,766 S	2/2014	Ryan et al.
D596,205 S	7/2009	Kawashiri et al.	D702,608 S	4/2014	Hall et al.
D596,671 S	7/2009	Sauter	D702,610 S	4/2014	Hall et al.
D597,007 S	7/2009	Ferman	D703,699 S	4/2014	Shimomura et al.
D598,831 S	8/2009	Honsel et al.	D704,749 S	5/2014	Shimomura et al.
D600,183 S	9/2009	Habib	D704,750 S	5/2014	Shimomura et al.
D600,185 S	9/2009	Habib	D706,841 S	* 6/2014	Shimomura ..... D15/31
D602,047 S	* 10/2009	Kushita ..... D15/23	D707,729 S	* 6/2014	Jackson ..... D15/31
D602,507 S	10/2009	Kushita	D707,730 S	* 6/2014	Jackson ..... D15/31
D602,616 S	10/2009	Okamura et al.	D709,419 S	7/2014	Watkins
D602,991 S	10/2009	Sauter	D710,264 S	8/2014	Watkins et al.
D603,881 S	11/2009	Tamplain, III et al.	D711,302 S	8/2014	van Braeckel
D605,207 S	12/2009	Menges et al.	D711,930 S	* 8/2014	Kuwae ..... D15/31
D605,668 S	12/2009	Matsumoto et al.	D714,838 S	* 10/2014	Shimomura ..... D15/31
D607,391 S	1/2010	Krauss	D715,332 S	10/2014	Kuwae
D609,750 S	2/2010	Sauter	D716,348 S	* 10/2014	Ryan ..... D15/31
D611,963 S	3/2010	Kuwae et al.	D716,846 S	* 11/2014	Carter ..... D15/31
D613,220 S	4/2010	Ikeda et al.	D717,838 S	11/2014	Kuwae et al.
D613,224 S	4/2010	Beigel et al.	D720,370 S	12/2014	Carter et al.
D613,313 S	4/2010	Bhanuprakash	D720,371 S	12/2014	Furukawa et al.
D614,105 S	4/2010	Elliott et al.	D720,871 S	1/2015	Lim et al.
D614,205 S	4/2010	Kuwae et al.	D721,105 S	1/2015	Okuyama et al.
D620,157 S	7/2010	Frenzel et al.	D721,742 S	1/2015	Lee et al.
D620,503 S	* 7/2010	Krogh ..... D15/31	D721,994 S	2/2015	Graber et al.
D620,955 S	* 8/2010	Krogh ..... D15/31	D727,371 S	4/2015	Rhayakar et al.
D621,757 S	8/2010	Denet	D728,631 S	5/2015	Richard et al.
D623,104 S	9/2010	Akasawa et al.	D728,640 S	5/2015	Turner et al.
D625,741 S	10/2010	Seidel et al.	D729,281 S	5/2015	Carter et al.
D628,599 S	12/2010	Major	D729,282 S	5/2015	Sasaki
D629,017 S	12/2010	Major	D733,767 S	* 7/2015	Kushita ..... D15/31
D629,818 S	12/2010	Rummer et al.	D734,781 S	7/2015	Schnering et al.
D631,489 S	* 1/2011	Booth ..... D15/31	D736,270 S	8/2015	Jackson et al.
D632,312 S	* 2/2011	Booth ..... D15/31	D740,976 S	10/2015	Ko et al.
D632,704 S	2/2011	Seidel et al.	D743,065 S	11/2015	Weil
D636,000 S	4/2011	Kim et al.	D748,677 S	* 2/2016	Kushita ..... D15/26
D637,127 S	5/2011	Faghihzadeh	D749,148 S	2/2016	Darekar et al.
D641,027 S	* 7/2011	Kawashiri ..... D15/23	D751,611 S	3/2016	Smith et al.
D642,597 S	8/2011	Krogh et al.	D753,194 S	* 4/2016	Jackson ..... D15/31
D643,444 S	8/2011	Colvin et al.	D754,210 S	* 4/2016	Margutti ..... D15/23
D646,305 S	* 10/2011	Krogh ..... D15/31	D755,256 S	* 5/2016	Okuyama ..... D15/31
D646,333 S	10/2011	Davis	D756,003 S	5/2016	Kong et al.
D649,584 S	11/2011	Kovaliv	D756,421 S	* 5/2016	Okuyama ..... D15/26
D650,816 S	12/2011	Koponen et al.	D760,410 S	6/2016	Arroba
D655,317 S	* 3/2012	Hagele ..... D15/31	D763,756 S	8/2016	Enz
D655,318 S	* 3/2012	Hagele ..... D15/31	D765,740 S	* 9/2016	Jackson ..... D15/31
D659,060 S	5/2012	Inoue et al.	D766,340 S	* 9/2016	Jackson ..... D15/31
D659,722 S	5/2012	Blind et al.	D766,341 S	* 9/2016	Jacobsthal ..... D15/31
D660,755 S	5/2012	Inoue et al.	D768,210 S	* 10/2016	Jacobsthal ..... D15/31
D660,874 S	5/2012	Werner et al.	D772,309 S	* 11/2016	Underhill ..... D15/31
D660,879 S	5/2012	Laugerette	D774,111 S	12/2016	Underhill et al.
D660,881 S	5/2012	Böhme et al.	D775,033 S	12/2016	Wang
D661,323 S	* 6/2012	Krogh ..... D15/31	D775,244 S	12/2016	Hart et al.
D662,524 S	6/2012	Crookes et al.	D777,215 S	* 1/2017	Moritaka ..... D15/23
D663,229 S	7/2012	Waltersdorf	D777,219 S	* 1/2017	Hanke ..... D15/31
D663,752 S	7/2012	Hickman et al.	D777,220 S	* 1/2017	Powell ..... D15/31

D777,805 S	1/2017	Steinhardt et al.	
D777,957 S	1/2017	Ha et al.	
D778,963 S *	2/2017	Yang .....	D15/31
D780,231 S	2/2017	Saari et al.	
D780,232 S	2/2017	Saari et al.	
D780,233 S	2/2017	Saari et al.	
D780,235 S	2/2017	Kim	
D783,059 S *	4/2017	Okuyama .....	D15/23
D783,476 S	4/2017	Huang	
D784,425 S	4/2017	Cooksey et al.	
D785,050 S *	4/2017	Okuyama .....	D15/23
D785,051 S *	4/2017	Okuyama .....	D15/23
D785,053 S *	4/2017	Okuyama .....	D15/31
D785,681 S *	5/2017	Okuyama .....	D15/31
D786,945 S	5/2017	Smith et al.	
D787,721 S	5/2017	Lai	
D789,427 S *	6/2017	Jackson .....	D15/28
D791,659 S	7/2017	Ito et al.	
D792,300 S	7/2017	Ferman	
D792,483 S *	7/2017	Jackson .....	D15/28
D794,521 S	8/2017	Tseng	
D797,332 S	9/2017	Lin	
D800,038 S	10/2017	Ferman	
D802,871 S *	11/2017	Knje .....	D34/35
D803,435 S	11/2017	Cotner et al.	
D804,539 S *	12/2017	Okuyama .....	D15/31
D808,315 S	1/2018	Danze	
D809,682 S	2/2018	Lin	
D815,001 S	4/2018	Banceu et al.	
D815,577 S	4/2018	Chiang	
D822,241 S	7/2018	Lee et al.	
D824,058 S	7/2018	Hong et al.	
D824,305 S	7/2018	Henry et al.	
D828,245 S	9/2018	Scott	
D863,160 S	10/2019	Gifford et al.	
D865,600 S	11/2019	Goodrich et al.	
D867,249 S	11/2019	Chen	
2004/0123504 A1	7/2004	Williams, Jr.	
2014/0217718 A1	8/2014	O'Donnell et al.	
2015/0307033 A1	10/2015	Preisler et al.	
2018/0117954 A1	5/2018	Brown	

FOREIGN PATENT DOCUMENTS

CN	304913471 S	11/2018
CN	305100471 S	5/2019
KR	300611812 S	9/2011
KR	300789169 S	3/2015

OTHER PUBLICATIONS

Agritechnica 2017—Gold and Silver, <https://www.agritechnica.com/en/innovation-award/gold-and-silver/>, accessed Dec. 5, 2017, 18 pages.

Deutz-Fahr 6 Series, available at least as early as May 2015, 32 pages.

Deere flared fenders, available at least as early as May 2015, 1 page.

Deere reverse decal, available at least as early as May 2015, 1 page.

Big 4, available at least as early as May 2015, 1 page.

Cub Cadet, available at least as early as May 2015, 1 page.

Massey Ferguson, available at least as early as May 2015, 1 page.

International Harvester, available at least as early as May 2015, 1 page.

Deutz-Fahr (7250 TTV Warrior), available at least as early as May 2015, 4 pages.

Deere & Co., Deere 8 Series, 2015, 6 pages.

AGCO, Fendt 900 Series, 2012, 28 pages.

CASE Magnum 180-380 Brochure, 2014, 28 pages.

AGCO, Fendt 300Vario, available at least as early as May 2015, 23 pages.

AGCO, Fendt 500Vario, available at least as early as May 2015, 25 pages.

AGCO, Fendt 700 series brochure, 2012, 32 pages.

AGCO, Fendt 800 Vario, 2014, 4 pages.

AGCO, Fendt X Concept Tractors, retrieved from <http://www.fendt.com/us/2466.asp> May 18, 2015, 3 pages.

CASE Puma Series Brochure, 2011, 28 pages.

50 HP Blue Sonalika DI 47 Rx Tractor, retrieved from Internet <https://www.indiamart.com/proddetail/sonalika-di-47-rx-tractor-19114279955.html> Jun. 26, 2019, 5 pages.

CASE Farmall A Series Tractors Brochure, 2011, 7 pages.

CASE Farmall C Tractors Brochure, 2013, 16 pages.

CASE Farmall U Tractors Brochure 11-13, 2013, 12 pages.

CASE Maxxum Series Tractors Brochure, 2012, 24 pages.

CASE Steiger Tractor Brochure, 2014, 32 pages.

Challenger MT 465 B Tractor Decals, retrieved from Internet <https://equipment-decals.myshopify.com/products/challenger-mt-465-b-tractor-decals> Jun. 26, 2019, 5 pages.

Deutz 5 series brochure, publicly available before May 2015, 24 pages.

Deutz 308 8514 3 4-1 Serie7 Agrottron, publicly available before May 2015, 28 pages.

Deutz-Fahr, Deutz Agroclimber F-V—Tractors Crawlers, retrieved from Internet <http://www.deutz-fahr.com/en-US/products/tractors/722-agroclimber-f-v> May 19, 2015, 5 pages.

Deutz agrofarm-g brochure, publicly available before May 2015, 11 pages.

Deutz-Fahr, Deutz Agrolux 65-75—Tractors Open field, retrieved from internet <http://www.deutz-fahr.com/en-US/products/tractors/835-agrolux-65-75> May 19, 2015, 4 pages.

Deutz-Fahr, Deutz Agrolux 310-320-410—Tractors Open field, retrieved from internet <http://www.deutz-fahr.com/en-US/products/tractors/864-agrolux-310-320-410> May 19, 2015, 4 pages.

AGCO, Fendt 200Vario, publicly available before May 2015, 17 pages.

John Deere Pedal Tractor Decals Tractors, retrieved from Internet <http://todayview.co/ideas/> Jun. 26, 2019, 3 pages.

Mahindra Jivo 245, retrieved from Internet <https://tractorsinfo.com/mahindra-jivo-245-di-4wd-mini-tractor-price-list/> Jun. 26, 2019, 9 pages.

Mahindra Tractor Jivo 245 DI, retrieved from internet <https://www.tractorjunction.com/product/370/mahindra-tractor-jivo-245-di> Jun. 26, 2019, 5 pages.

Solis 75N Traktor Schlepper Kein New Holland, retrieved from internet <https://www.mascus.com/agriculture/used-tractors/solis-75n-traktor-schlepper-kein-new-h> Jun. 26, 2019, 3 pages.

Tractor Decals, retrieved from Internet <https://www.indiamart.com/proddetail/tractor-decals-10179545988.html>, Jun. 29, 2019, 4 pages.

Mahindra targets 50% share in domestic tractor market with Trakstar brand, retrieved from internet <https://www.moneycontrol.com/news/technology/auto/mahindra-targets-50-share-in-domestic-tractor-market-with-trakstar-brand-2645381.html> Jun. 27, 2019, 6 pages.

Hagner et al., Operator Station for Work Vehicle, unpublished U.S. design Appl. No. 29/647,298 filed May 11, 2018, 101 pages.

\* cited by examiner

Primary Examiner — Mark A Goodwin

(57) CLAIM

The ornamental design for a work machine, as shown and described.

DESCRIPTION

FIG. 1 is a top, front, left perspective view of a work machine embodying our new design;

FIG. 2 is a left side elevational view thereof;

FIG. 3 is a right side elevational view thereof;

FIG. 4 is a front elevational view thereof;

FIG. 5 is a rear elevational view thereof;

FIG. 6 is a top plan view thereof; and,

FIG. 7 is a bottom plan view thereof.

The broken line representations in the figures show unclaimed environment or boundaries, and thus form no part of the claimed design.

**1 Claim, 7 Drawing Sheets**

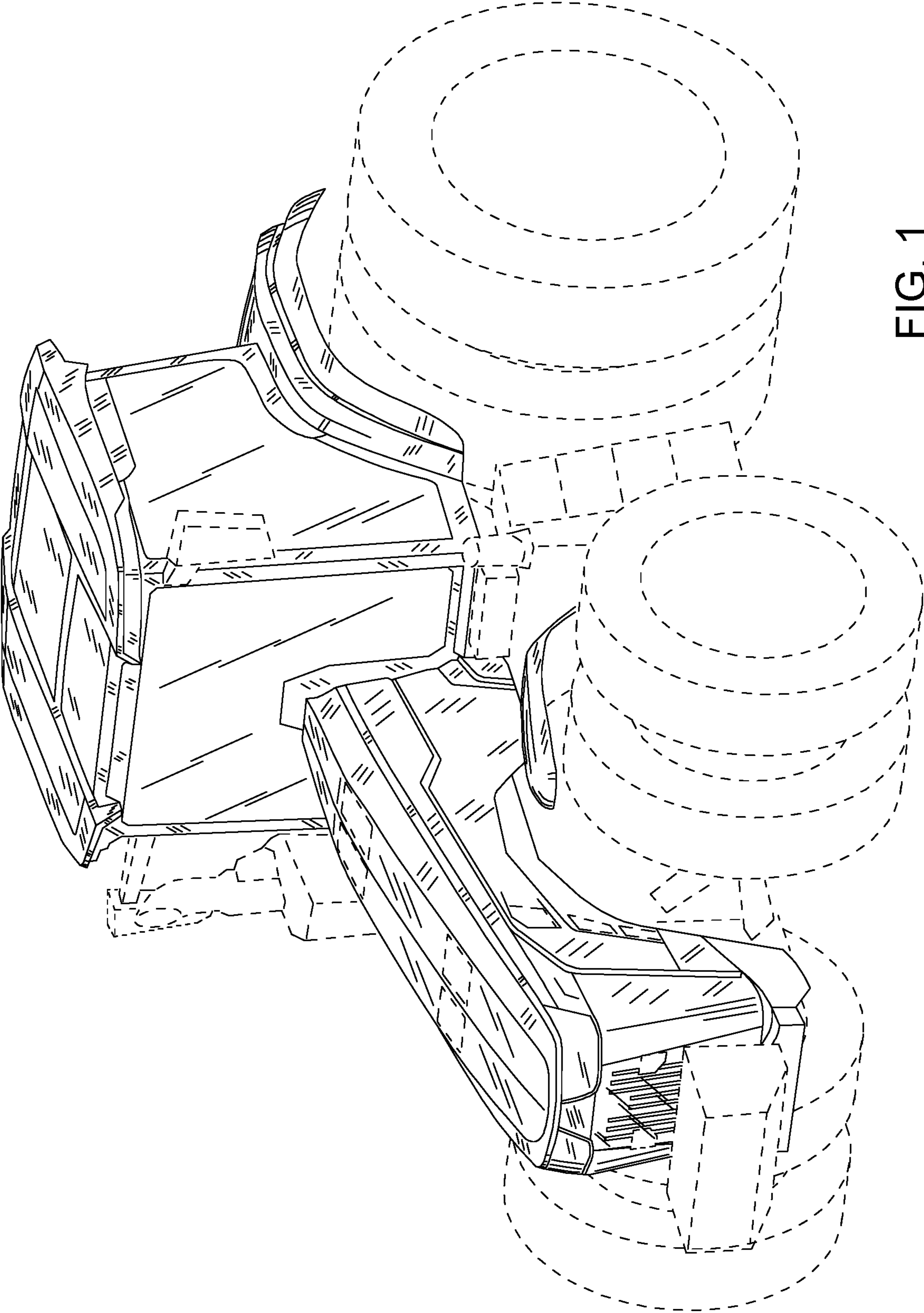

FIG. 1

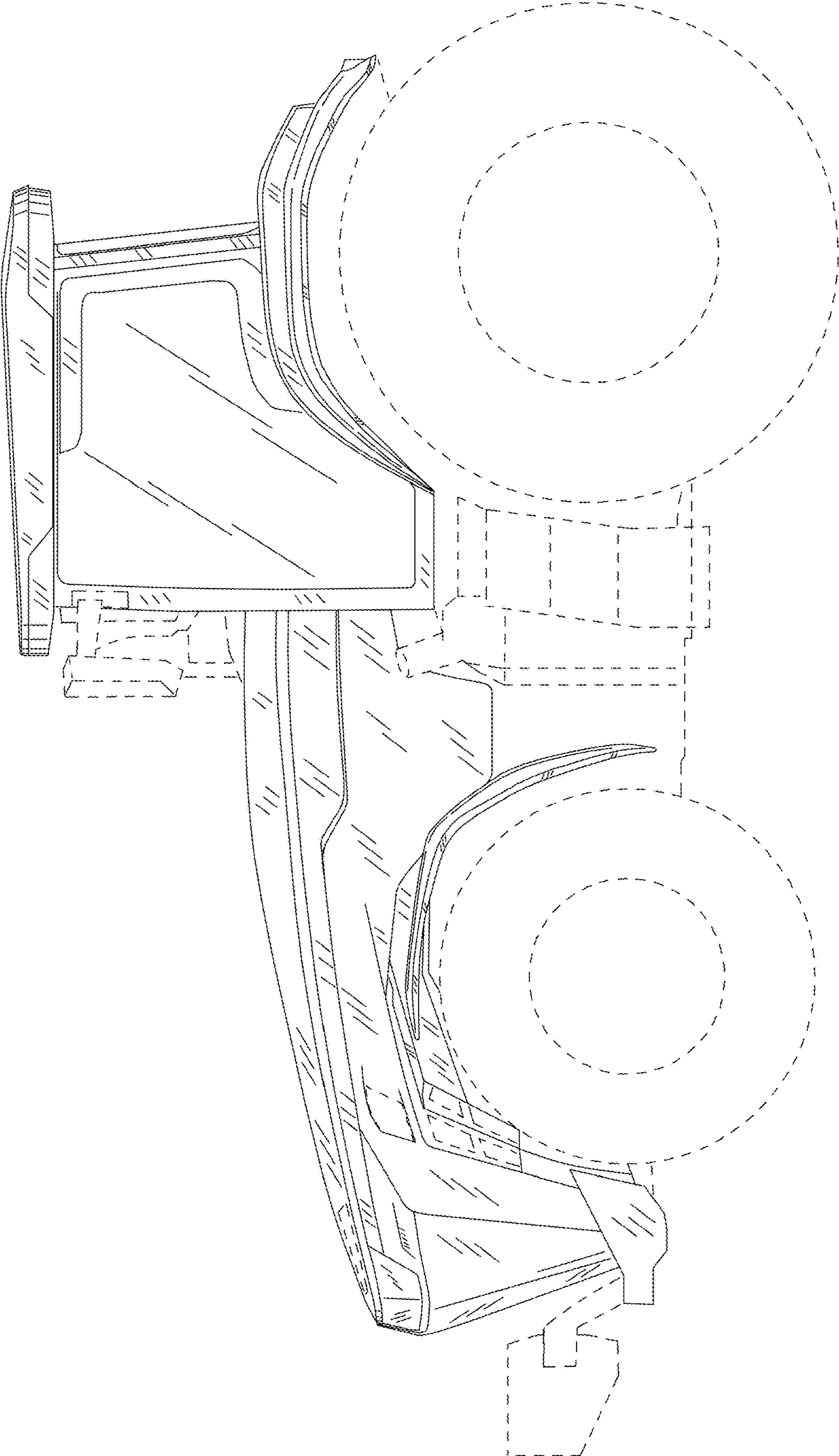

FIG. 2

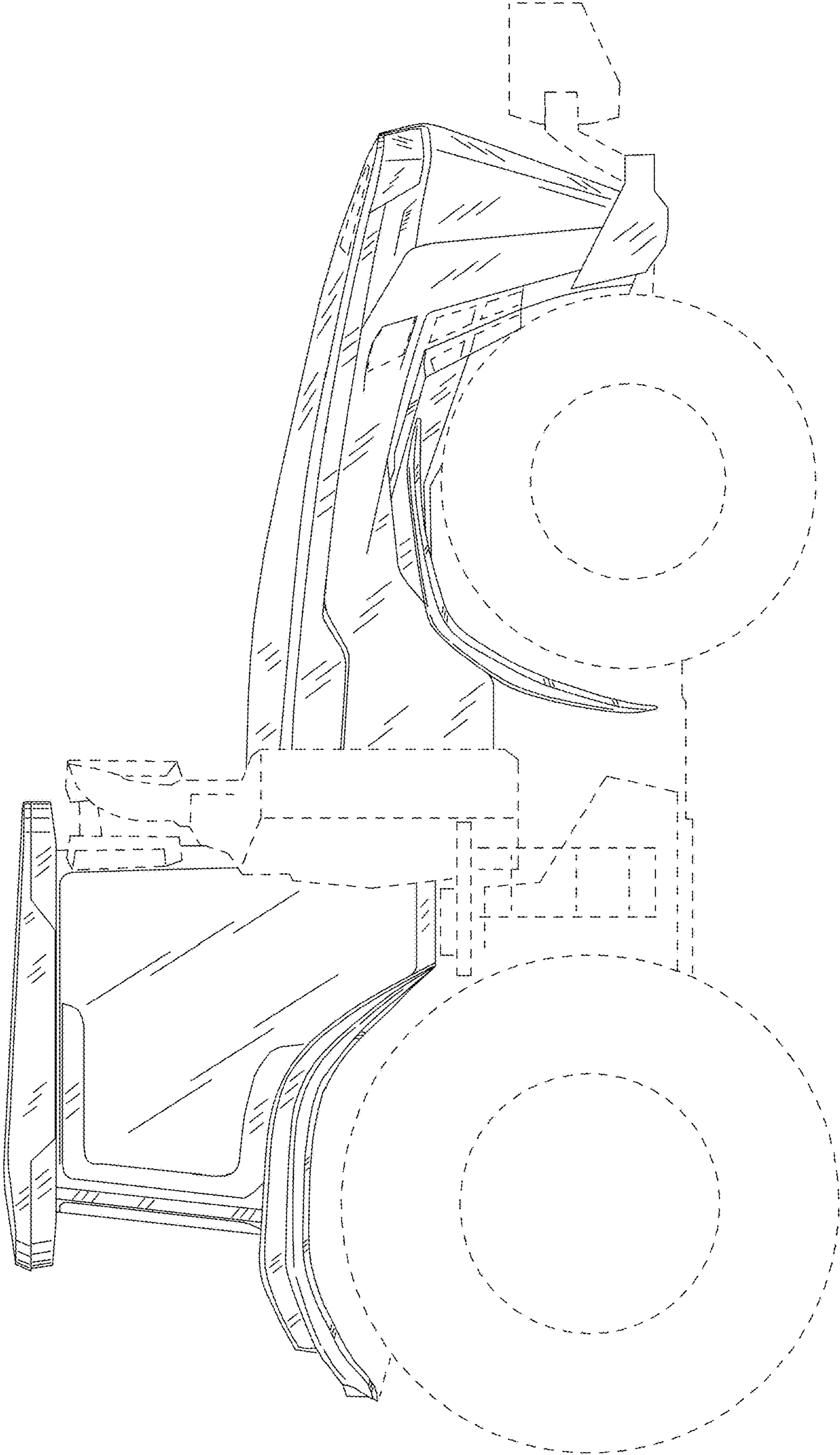

FIG. 3

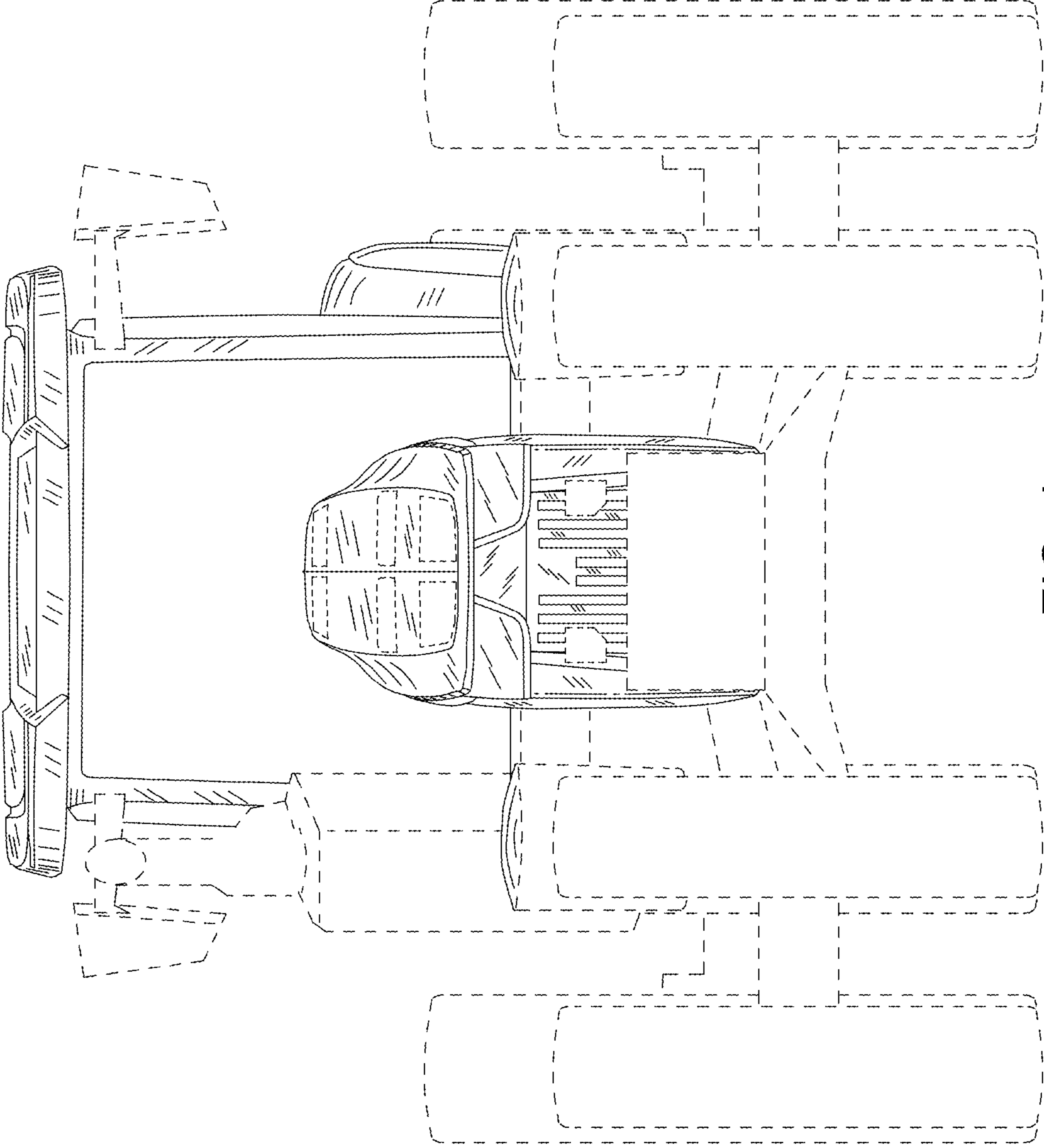

FIG. 4



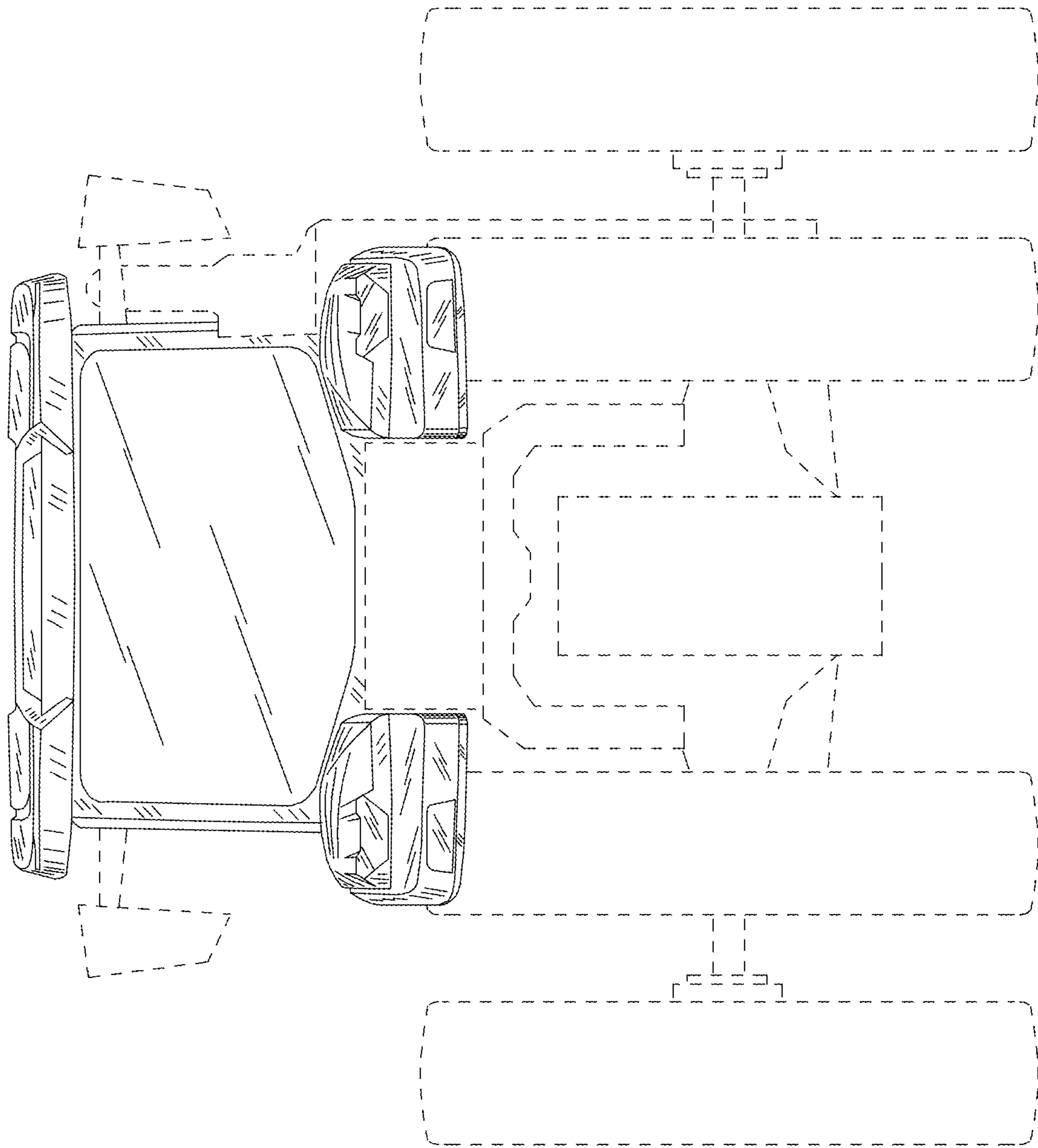

FIG. 5

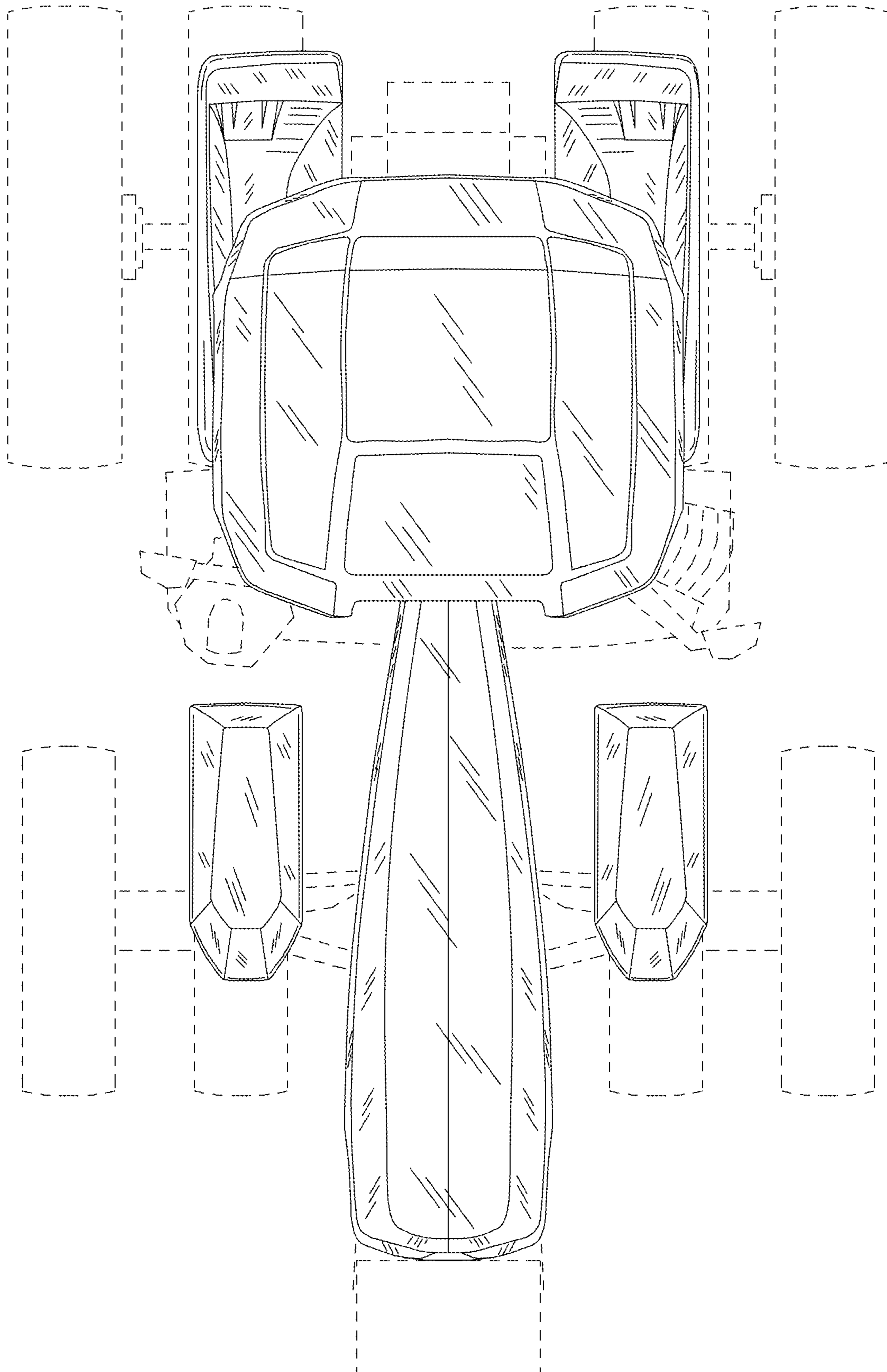

FIG. 6

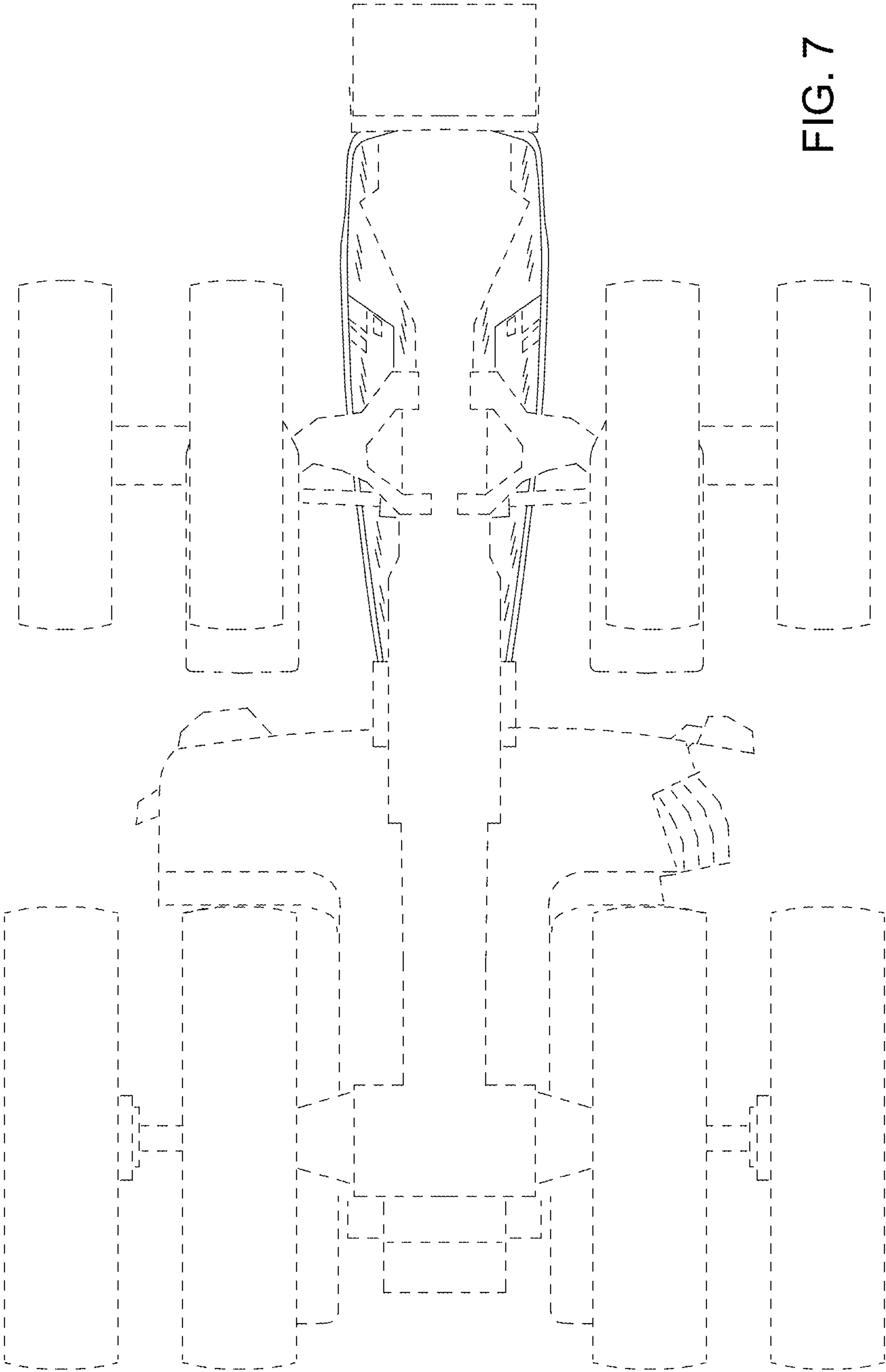

FIG. 7