



US00D909949S

(12) **United States Design Patent** (10) **Patent No.:** **US D909,949 S**
Williams et al. (45) **Date of Patent:** **** *Feb. 9, 2021**

(54) **TILTROTOR AIRCRAFT**

(71) Applicant: **Bell Helicopter Textron Inc.**, Fort Worth, TX (US)

(72) Inventors: **Jeffrey M. Williams**, Hudson Oaks, TX (US); **James E. Kooiman**, Fort Worth, TX (US); **Clegg Smith**, Keller, TX (US); **Lynn F. Eschete**, Arlington, TX (US); **Jason P. Winter**, Fort Worth, TX (US); **Michael E. Rinehart**, Euless, TX (US); **Troy T. Bushmire**, Fort Worth, TX (US)

(73) Assignee: **Bell Helicopter Textron Inc.**, Fort Worth, TX (US)

(*) Notice: This patent is subject to a terminal disclaimer.

(**) Term: **15 Years**

(21) Appl. No.: **29/670,350**

(22) Filed: **Nov. 15, 2018**

(51) **LOC (13) Cl.** **12-07**

(52) **U.S. Cl.**
USPC **D12/326**

(58) **Field of Classification Search**
USPC D12/1-4, 16.1, 319-345; D21/436-455; D25/13, 199

(Continued)

(56) **References Cited**

U.S. PATENT DOCUMENTS

D128,173 S 7/1941 Oliver
D140,130 S 1/1945 Watter
(Continued)

OTHER PUBLICATIONS

Bill Carey, "Bell Unveils 'Vigilant' Unmanned Tiltrotor for U.S. Marine Corps;" Sep. 22, 2016.

(Continued)

Primary Examiner — Marissa J Cash

(74) *Attorney, Agent, or Firm* — Timmer Law Group, PLLC

(57) **CLAIM**

The ornamental design for a tiltrotor aircraft, substantially as shown and described.

DESCRIPTION

FIG. 1 is a front perspective view of a tiltrotor aircraft with the rotor nacelles facing forward, doors on the bottom of the fuselage open, and landing gear down;
FIG. 2 is a front elevational view of the aircraft in FIG. 1;
FIG. 3 is a rear elevational view thereof;
FIG. 4 is a right side view thereof;
FIG. 5 is a left side view thereof;
FIG. 6 is a top view thereof;
FIG. 7 is a bottom view thereof;
FIG. 8 is a front perspective view of the aircraft in FIG. 1 with the rotor nacelles facing upward, doors on the bottom of the fuselage open, and landing gear down;
FIG. 9 is a front elevational view of the aircraft in FIG. 8;
FIG. 10 is a rear elevational view thereof;
FIG. 11 is a right side view thereof;
FIG. 12 is a left side view thereof;
FIG. 13 is a top view thereof;
FIG. 14 is a bottom view thereof;
FIG. 15 is a front perspective view of the aircraft of FIG. 1 with the rotor nacelles facing forward, doors on the bottom of the fuselage closed, and landing gear up;
FIG. 16 is a front elevational view of the aircraft in FIG. 15;
FIG. 17 is a rear elevational view thereof;
FIG. 18 is a right side view thereof;
FIG. 19 is a left side view thereof;
FIG. 20 is a top view thereof;
FIG. 21 is a bottom view thereof;
FIG. 22 is a front perspective view of the aircraft of FIG. 1 with the rotor nacelles facing upward, doors on the bottom of the fuselage closed, and landing gear up;
FIG. 23 is a front elevational view of the aircraft in FIG. 22;
FIG. 24 is a rear elevational view thereof;
FIG. 25 is a right side view thereof;
FIG. 26 is a left side view thereof;

(Continued)

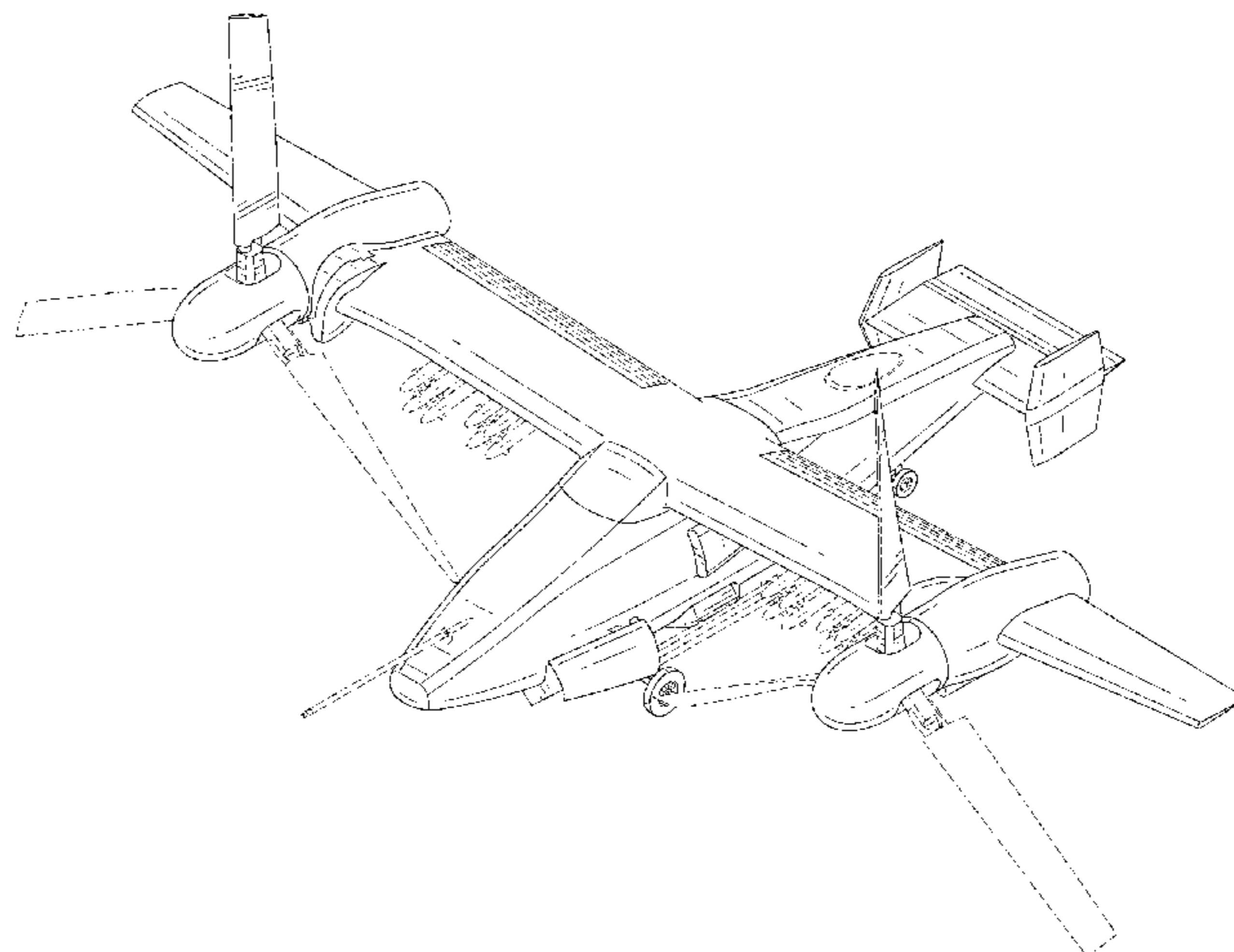

FIG. 27 is a top view thereof; and,
 FIG. 28 is a bottom view thereof.
 The broken lines in the drawings represent unclaimed environmental subject matter and form no part of the claim.

1 Claim, 28 Drawing Sheets

(58) **Field of Classification Search**

CPC B64C 29/0033; B64C 29/02; B64C 2201/021; B64C 2201/088; B64C 2201/104; B64C 2201/141; B64C 29/00; B64C 29/0025; B64G 2001/1064; B64G 2001/1071; B64G 5/00; B64G 1/46
 See application file for complete search history.

(56) **References Cited**

U.S. PATENT DOCUMENTS

D195,794	S	7/1963	Dancik	
D203,523	S	1/1966	Girard	
D311,719	S	10/1990	Haga	
D317,287	S	6/1991	Haga	
D317,897	S	7/1991	Antonov	
5,031,858	A	7/1991	Schellhase	
5,054,716	A	10/1991	Wilson	
D388,392	S	12/1997	McGinnis	
D394,422	S	5/1998	Magee	
D399,816	S	10/1998	Peacock	
D456,337	S	4/2002	Sankrithi	
D597,148	S	7/2009	Lin	
7,604,202	B2	10/2009	Froman	
D620,392	S *	7/2010	Rodriguez	D12/3
D624,001	S	9/2010	Saint-Jalmes	
D628,528	S	12/2010	Cabezas Carrasco	
D635,083	S	3/2011	DeLaurier	
D691,547	S	10/2013	Hall	
8,626,363	B2	1/2014	Kisor	
D706,678	S	6/2014	Earon	
D708,563	S	7/2014	Colten	
D713,774	S *	9/2014	Tritschler	D12/3
D725,548	S	3/2015	Herald	
D725,576	S	3/2015	Vickers	
D725,577	S	3/2015	Vickers	
9,051,046	B2	6/2015	Ivans	
D739,335	S *	9/2015	Robertson	D12/345
D739,807	S	9/2015	Strand	
D743,868	S	11/2015	Cummings	
D755,702	S	5/2016	Hall	
9,327,831	B2 *	5/2016	Schank	B64C 27/32
9,376,206	B2	6/2016	Ross	
D763,733	S	8/2016	Gattelli	
9,650,128	B2	5/2017	Fenny	
9,657,816	B2	5/2017	Burnett	
9,663,225	B1	5/2017	Kooiman	
D797,641	S	9/2017	Cummings	
D799,402	S	10/2017	Cummings	
D807,273	S	1/2018	Koppenwallner	
D808,328	S *	1/2018	Ivans	D12/328
D809,970	S	2/2018	Zhou	
D810,621	S	2/2018	Sadek	
D813,143	S	3/2018	Belik	

D814,970	S *	4/2018	Chen	D12/16.1
D824,320	S	7/2018	Ivans	
D824,321	S *	7/2018	Ivans	D12/327
D843,304	S *	3/2019	MacAndrew	D12/319
D843,305	S *	3/2019	MacAndrew	D12/319
D876,988	S *	3/2020	Stepura	D12/16.1
10,589,855	B2 *	3/2020	Groninga	B64D 27/02
10,640,205	B2 *	5/2020	Paulson	B64C 27/50
2010/0209242	A1	8/2010	Popelka	
2012/0043413	A1	2/2012	Smith	
2012/0199699	A1	8/2012	Isaac	
2012/0292456	A1	11/2012	Hollimon	
2013/0153708	A1	6/2013	Brunken	
2014/0084080	A1	3/2014	Robertson	
2014/0263855	A1	9/2014	Ross	
2014/0322010	A1	10/2014	Rauber	
2015/0048213	A1	2/2015	Ross	
2016/0023752	A1	1/2016	Foskey	
2016/0122039	A1	5/2016	Ehinger	
2016/0152329	A1	6/2016	Tzeng	
2016/0207611	A1	7/2016	Fenny	
2016/0229531	A1 *	8/2016	Robertson	B64C 39/04
2016/0333797	A1	11/2016	Laramee	
2016/0340038	A1	11/2016	Chavez	
2016/0347479	A1	12/2016	O'Neil	
2017/0036753	A1	2/2017	Shue	
2017/0121029	A1	5/2017	Blyth	
2017/0137122	A1	5/2017	Kooiman	
2017/0190443	A1	7/2017	Fisher	
2017/0291719	A1	10/2017	Lavine	
2017/0355460	A1	12/2017	Shannon	
2018/0079482	A1	3/2018	Ivans	
2018/0079484	A1 *	3/2018	Ross	B64C 7/02
2018/0079487	A1 *	3/2018	Ivans	B64C 3/56
2018/0079503	A1 *	3/2018	Ivans	B64D 33/04
2019/0233095	A1 *	8/2019	Baldwin	B64C 27/35
2019/0329863	A1 *	10/2019	King	B64C 29/0033
2019/0329867	A1 *	10/2019	Cravener	B64C 3/56
2019/0344877	A1 *	11/2019	Gilliland	B64C 29/0033
2020/0010183	A1 *	1/2020	Kizhakkepat	B64C 29/0033
2020/0056696	A1 *	2/2020	Fenny	B64D 35/00
2020/0070994	A1 *	3/2020	Rosado	F02K 1/825
2020/0086971	A1 *	3/2020	Heeringa	B64C 29/0033

OTHER PUBLICATIONS

Richard Whittle, "Month After Use, Bell Unveils V-247 Vigilant Tiltrotor Drone;" Sep. 22, 2016.
 Notice of Allowance, dated Jun. 21, 2017, by the USPTO, re Design U.S. Appl. No. 29/577,578.
 Notice of Allowance, dated Sep. 20, 2017, by the USPTO, re Design U.S. Appl. No. 29/577,578.
 Notice of Allowance, dated Jun. 8, 2018, by the USPTO, re Design U.S. Appl. No. 29/628,801.
 Notice of Allowance, dated Jun. 8, 2018, by the USPTO, re Design U.S. Appl. No. 29/628,827.
 Office Action, dated Sep. 7, 2018, by the USPTO, re Design U.S. Appl. No. 29/628,792.
 Final Rejection, dated Feb. 25, 2019, by the USPTO, re Design U.S. Appl. No. 29/628,792.
 DefenseNews; Video: Check out Bell's V-247 Vigilant at Modern Day Marine; Sep. 15, 2018; <https://www.defensenews.com/video/2018/09/25/check-out-bells-v-247-vigilant-at-modern-day-marine/>.

* cited by examiner

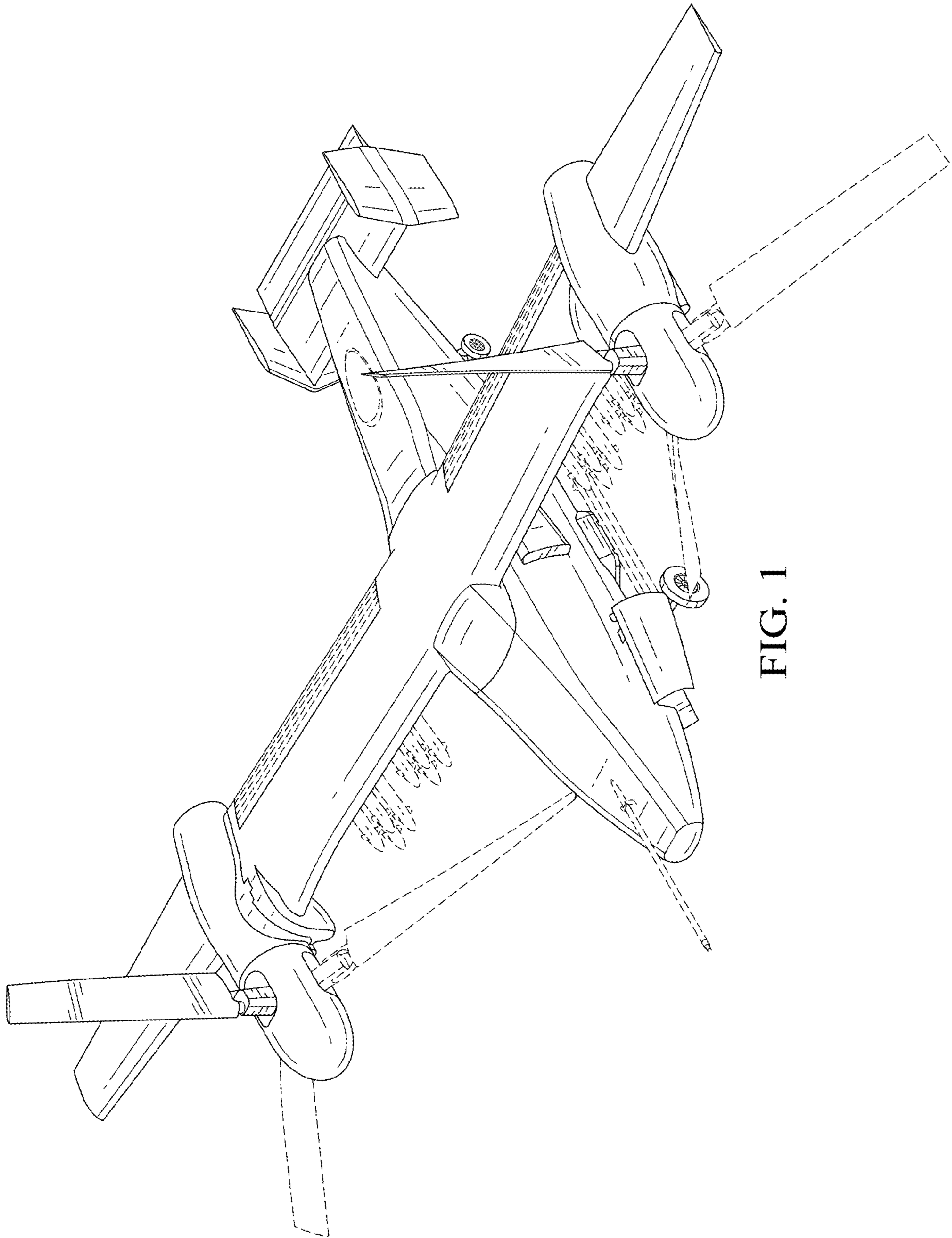

FIG. 1

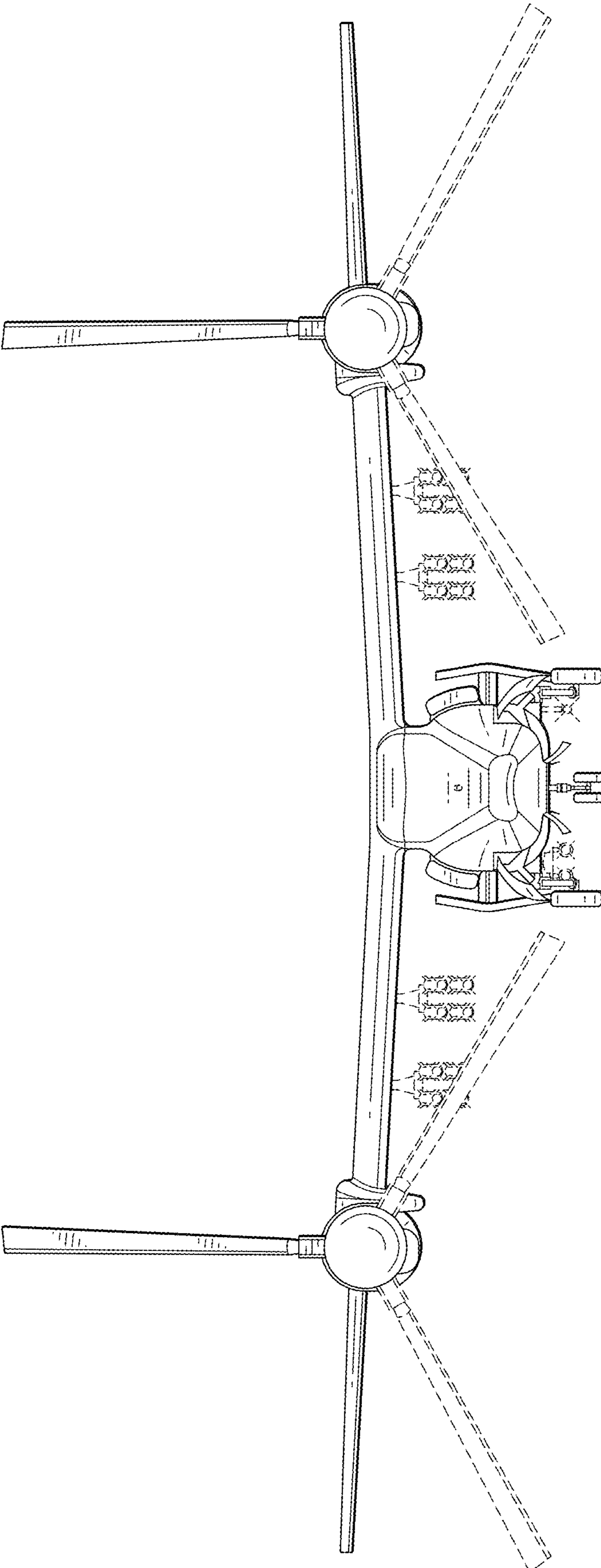

FIG. 2

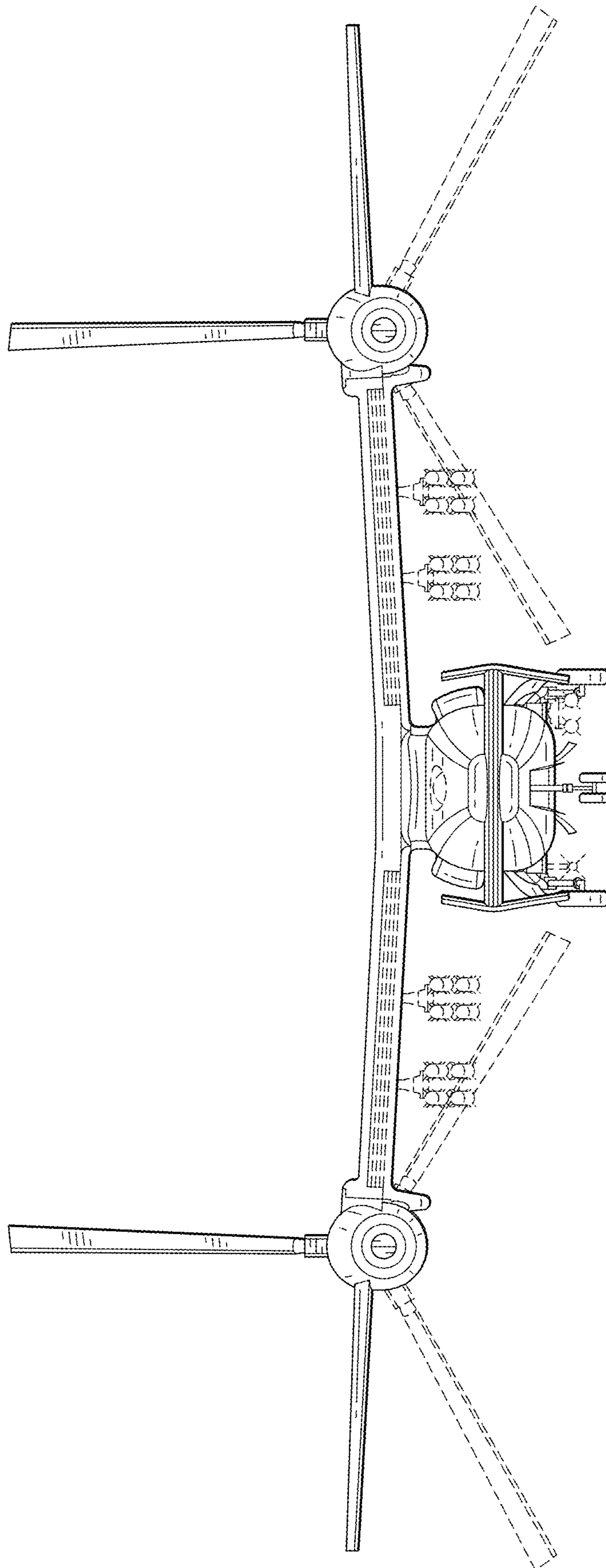

FIG. 3

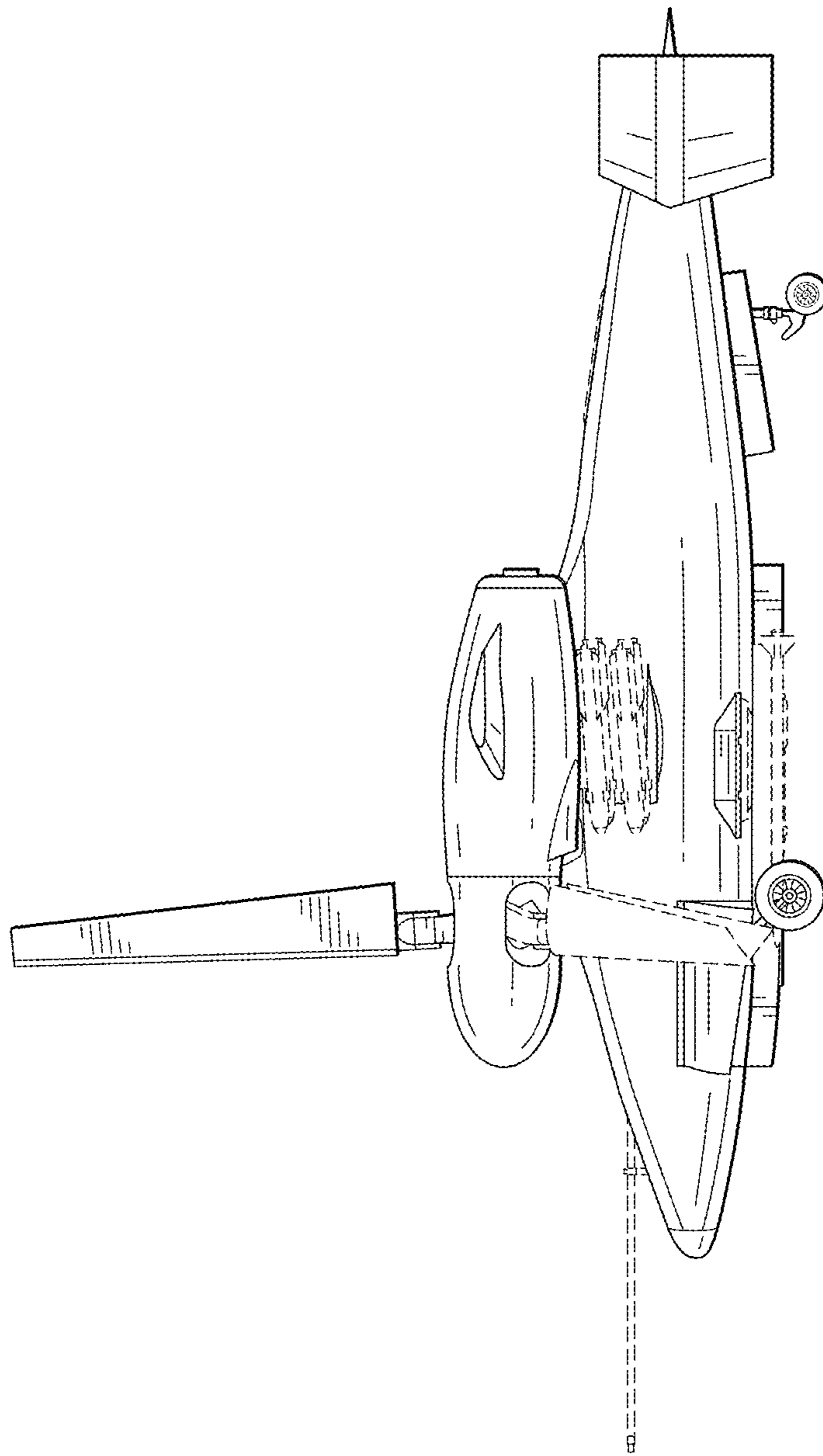

FIG. 4

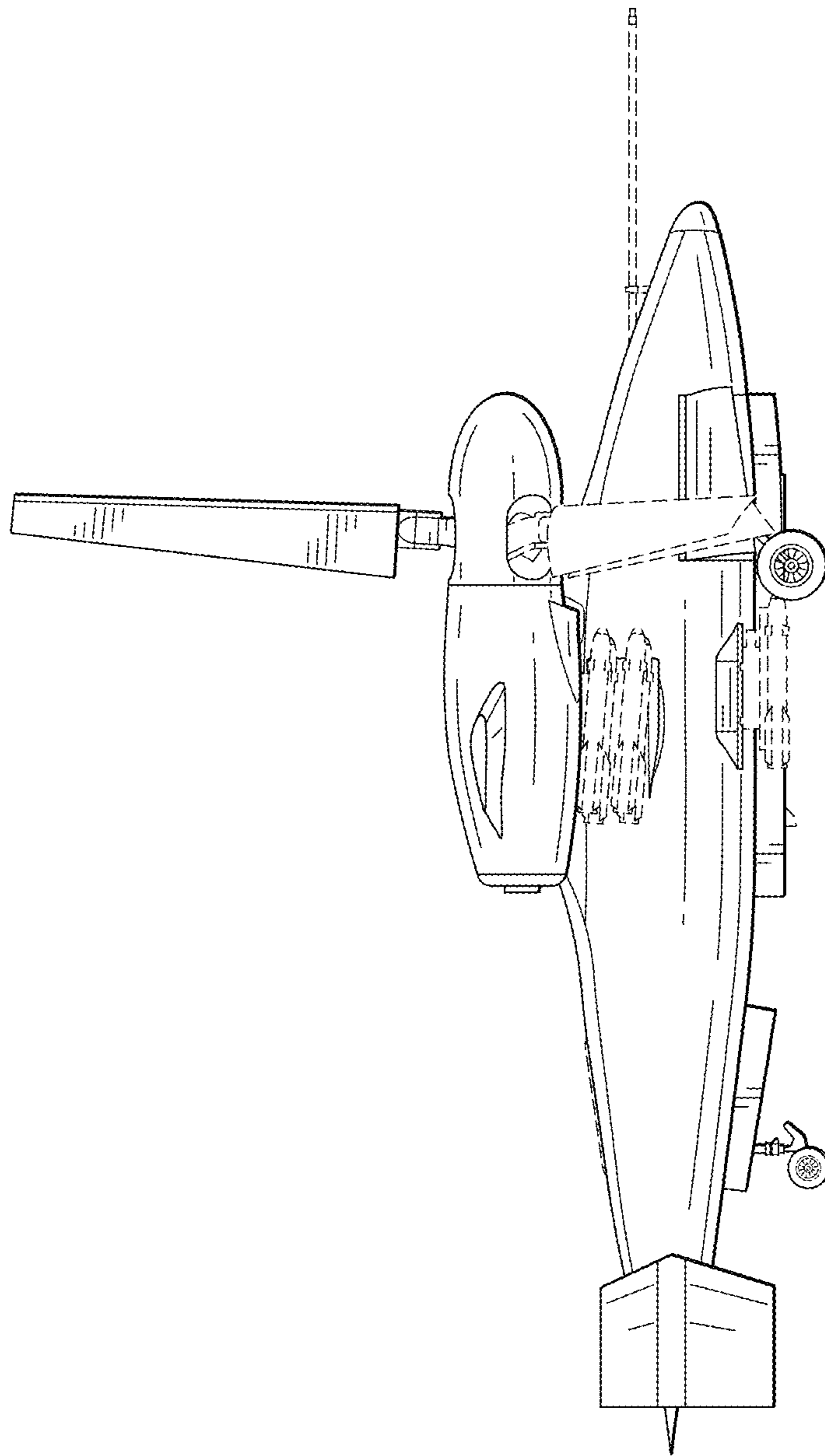

FIG. 5

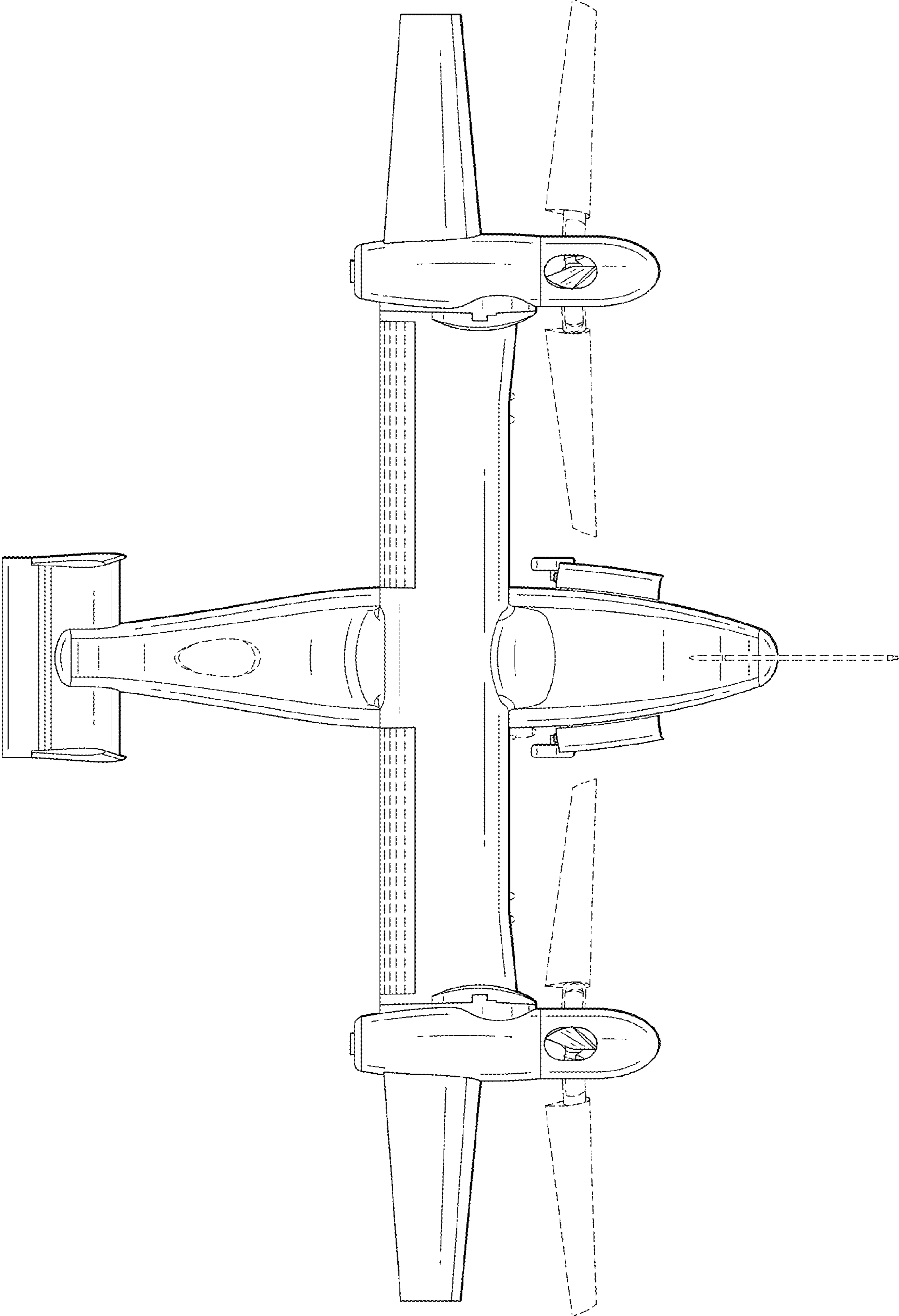

FIG. 6

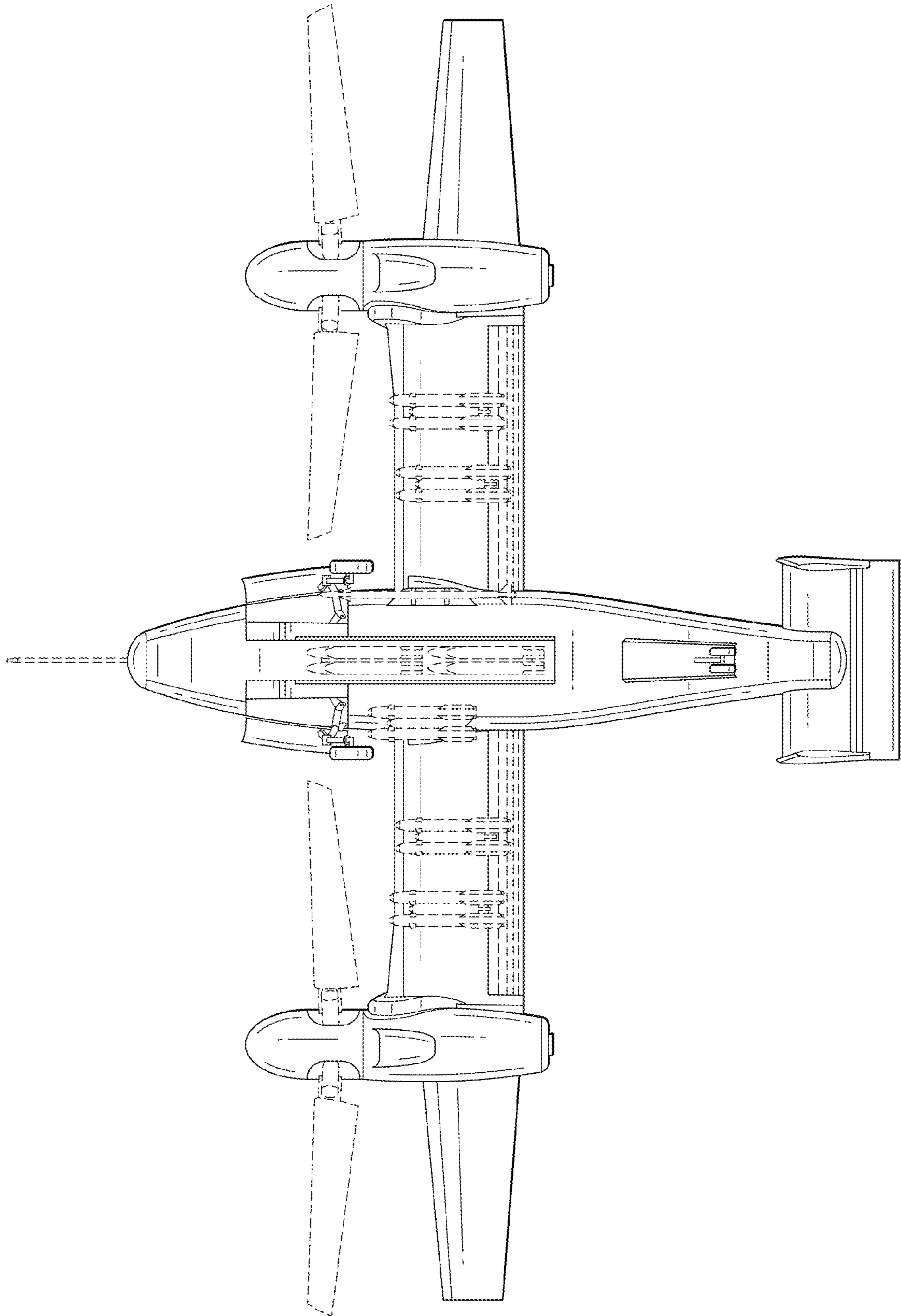

FIG. 7

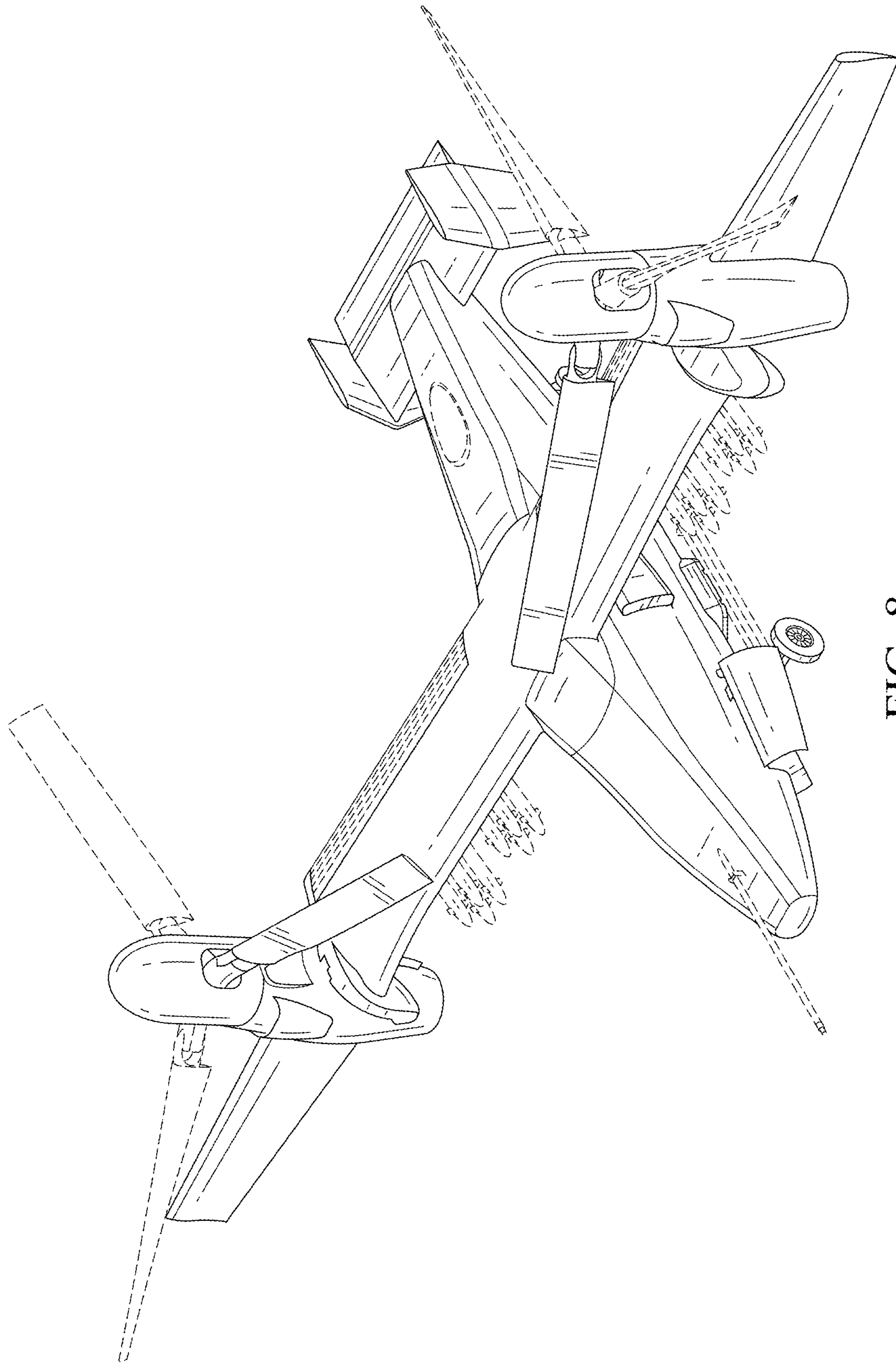

FIG. 8

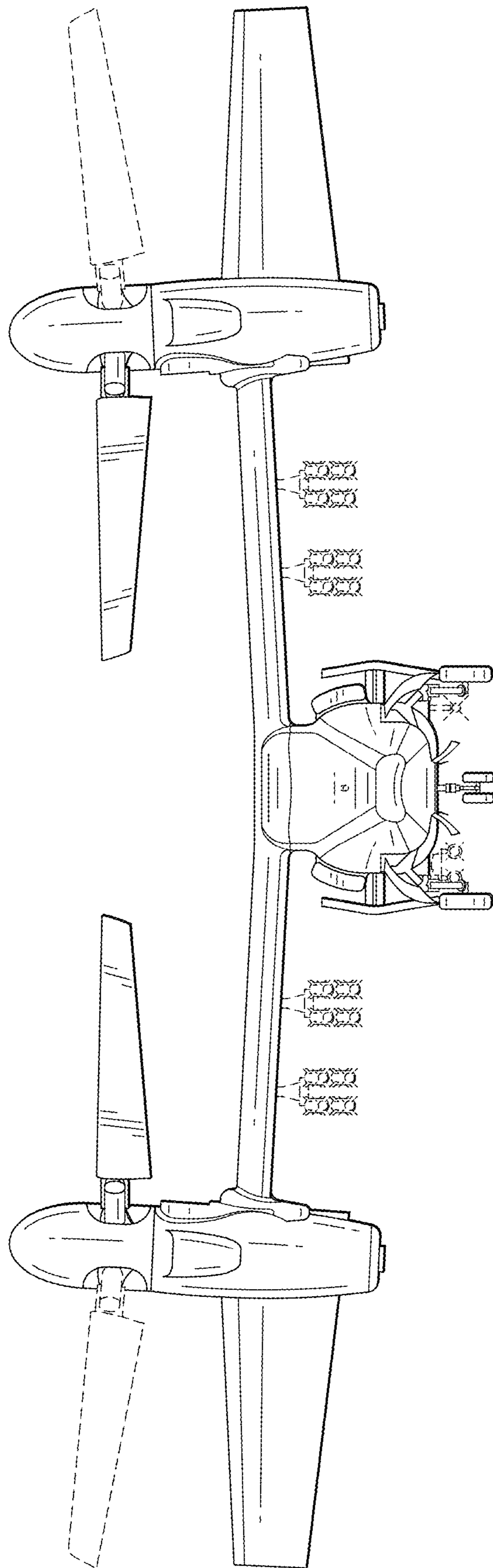

FIG. 9

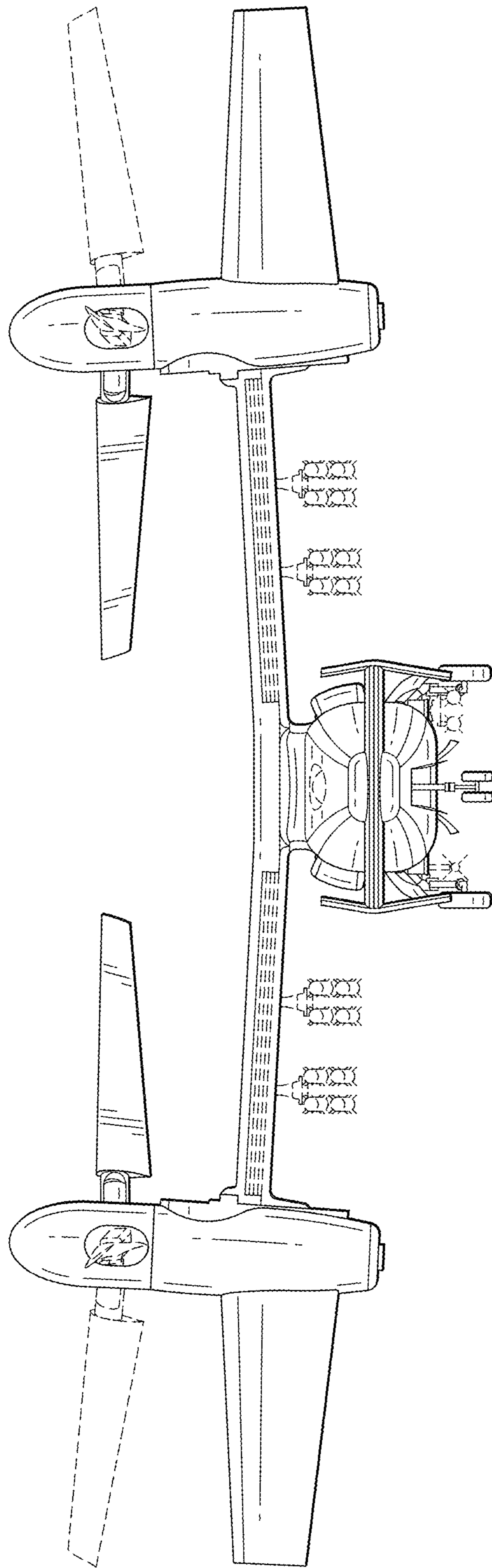

FIG. 10

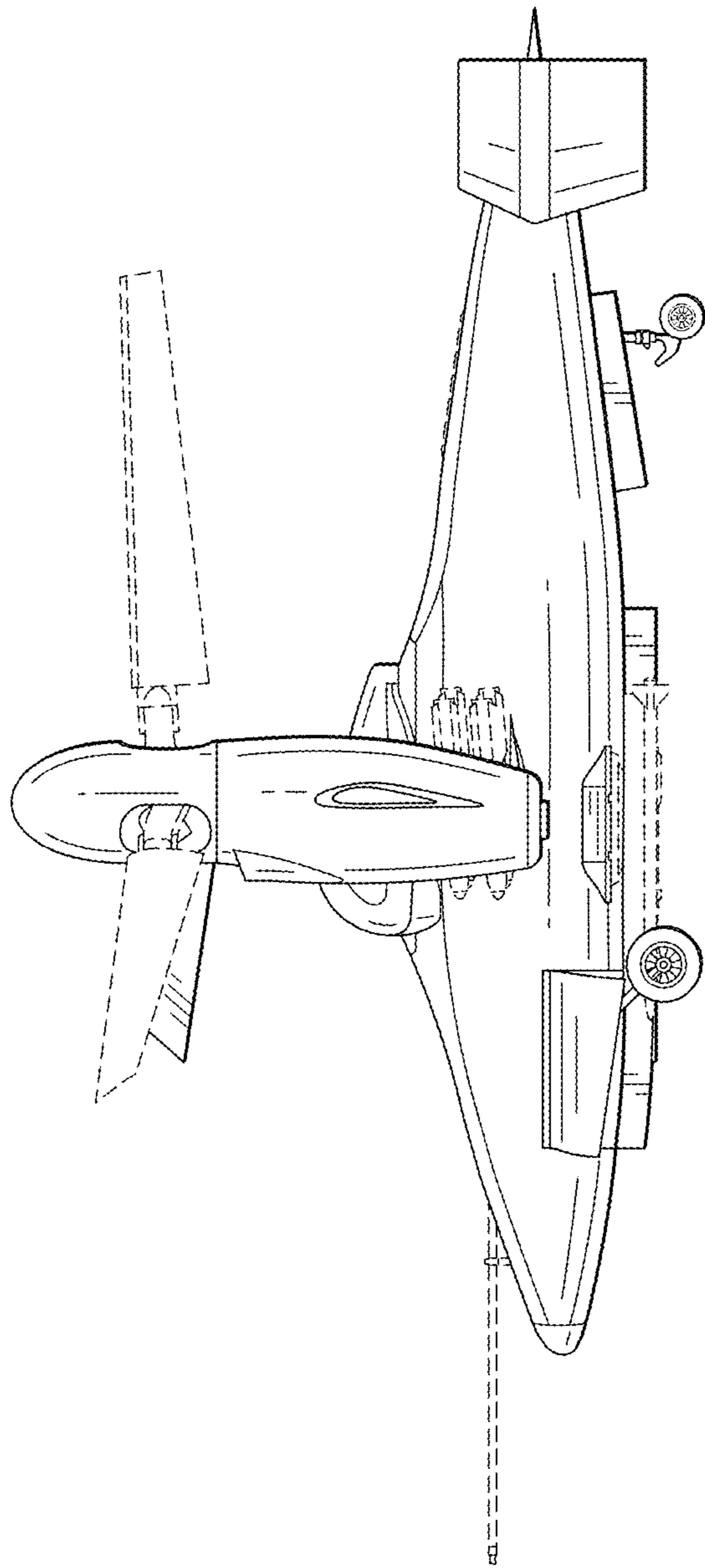

FIG. 11

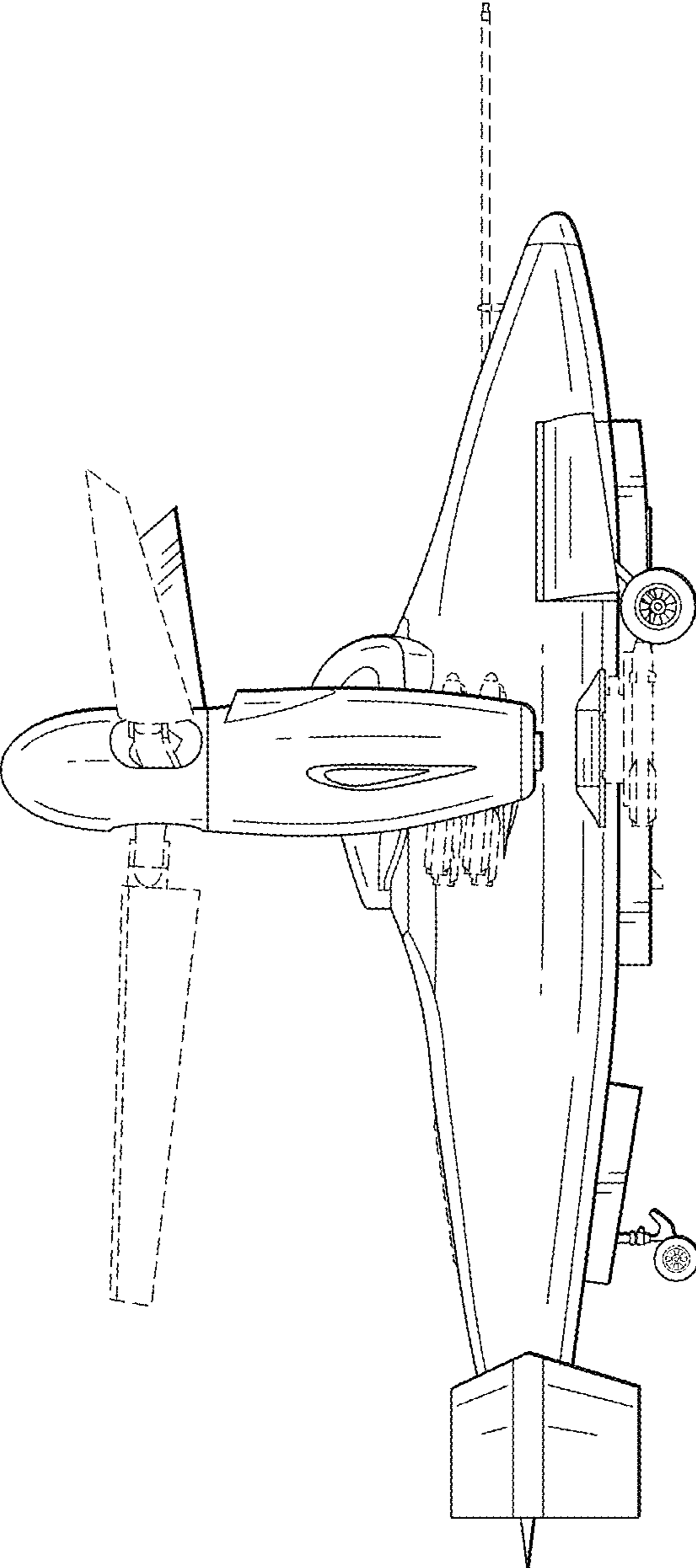

FIG. 12

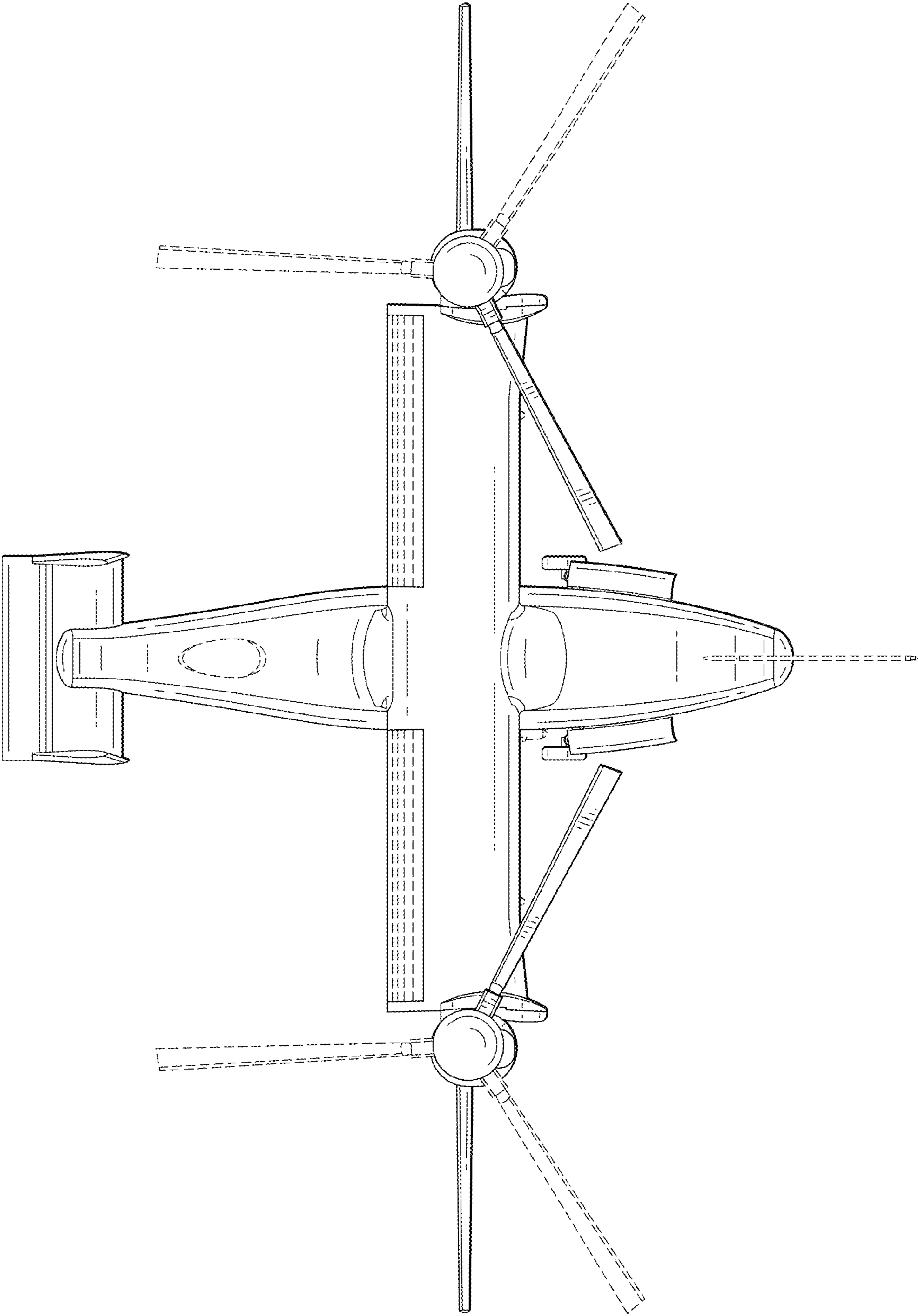

FIG. 13

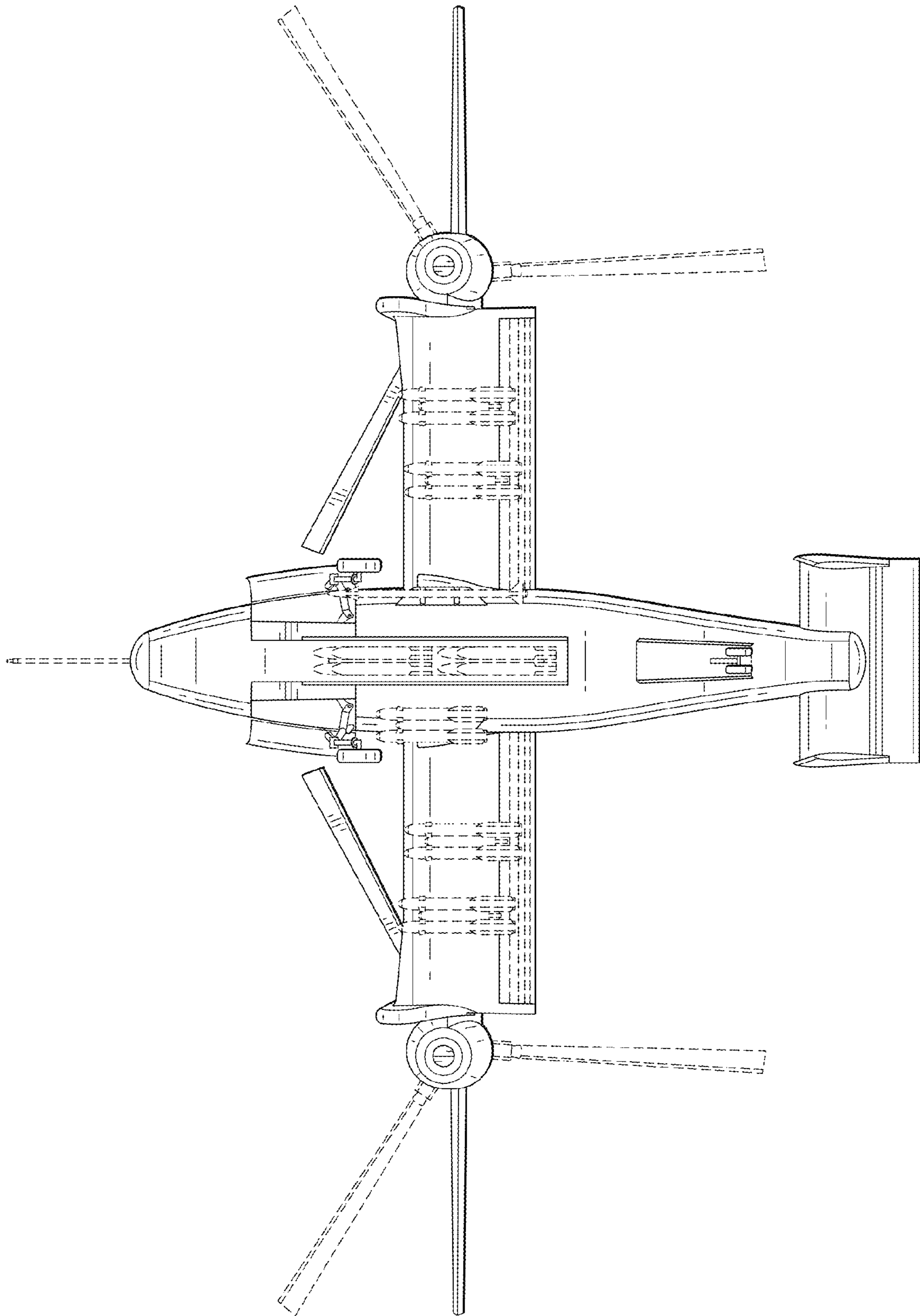

FIG. 14

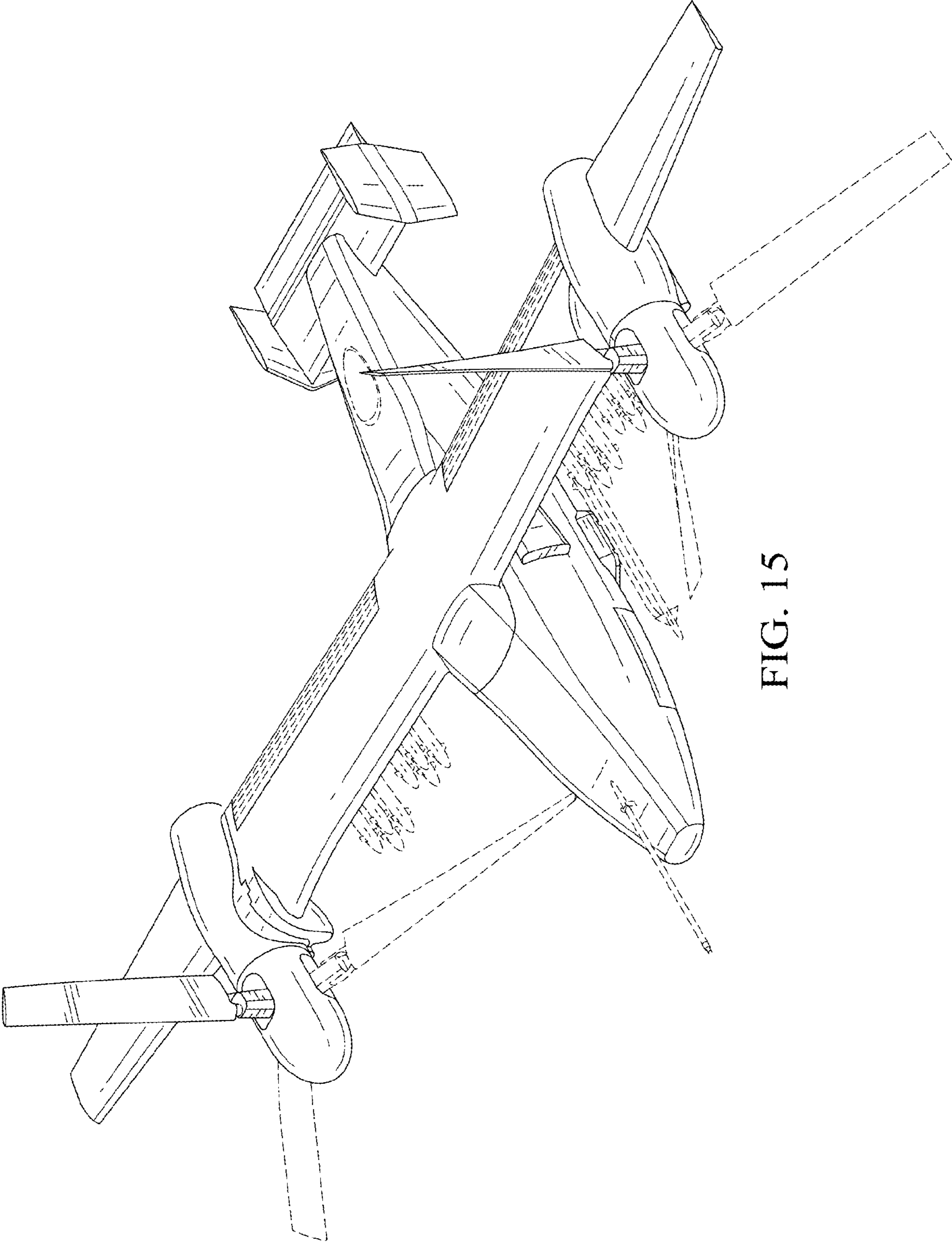

FIG. 15

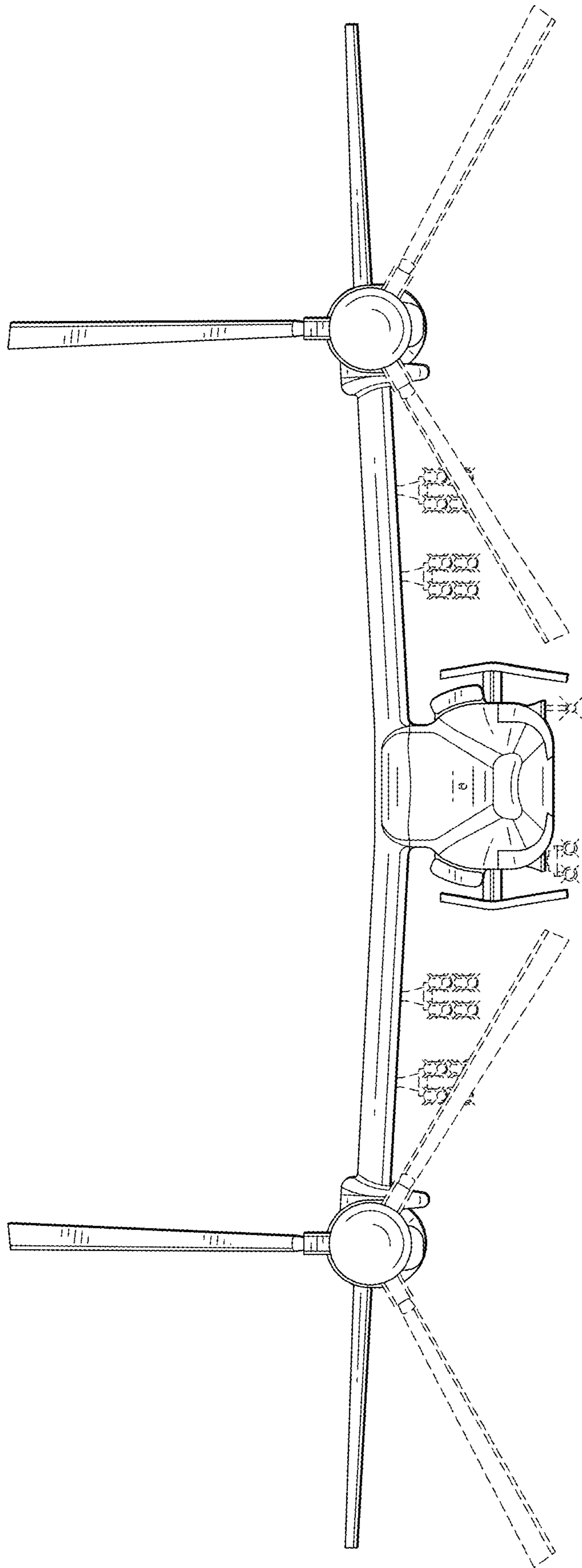

FIG. 16

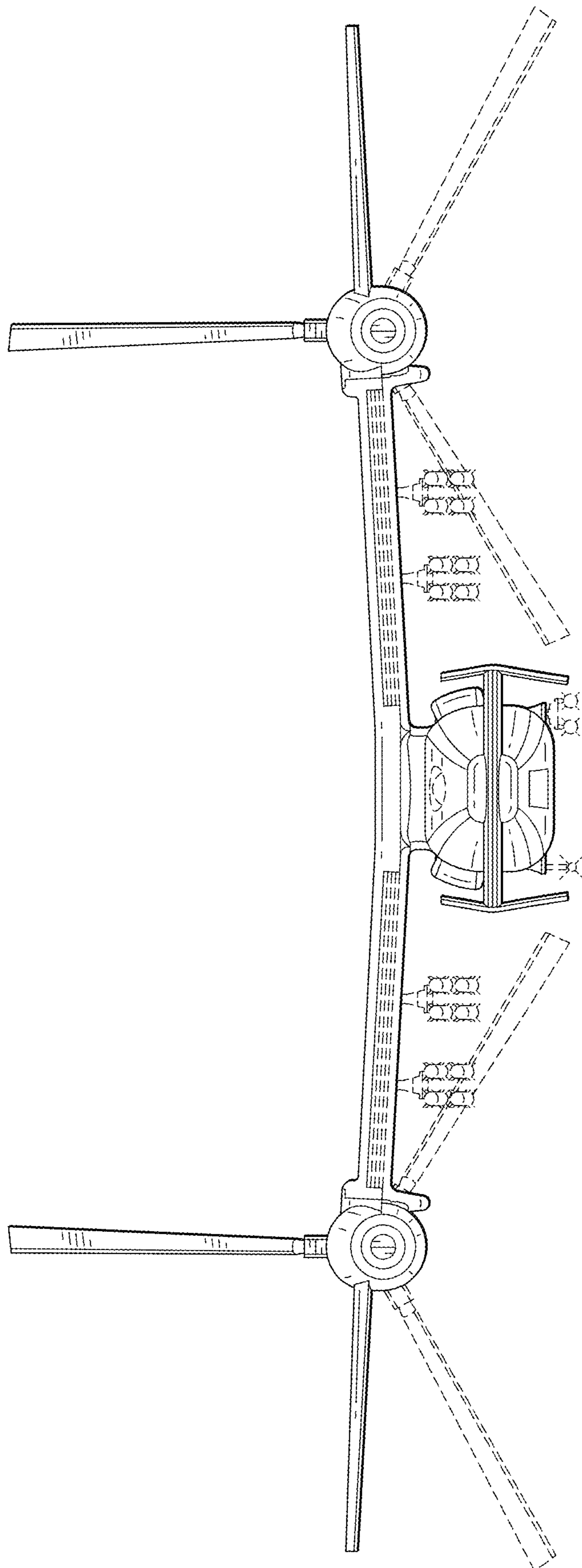

FIG. 17

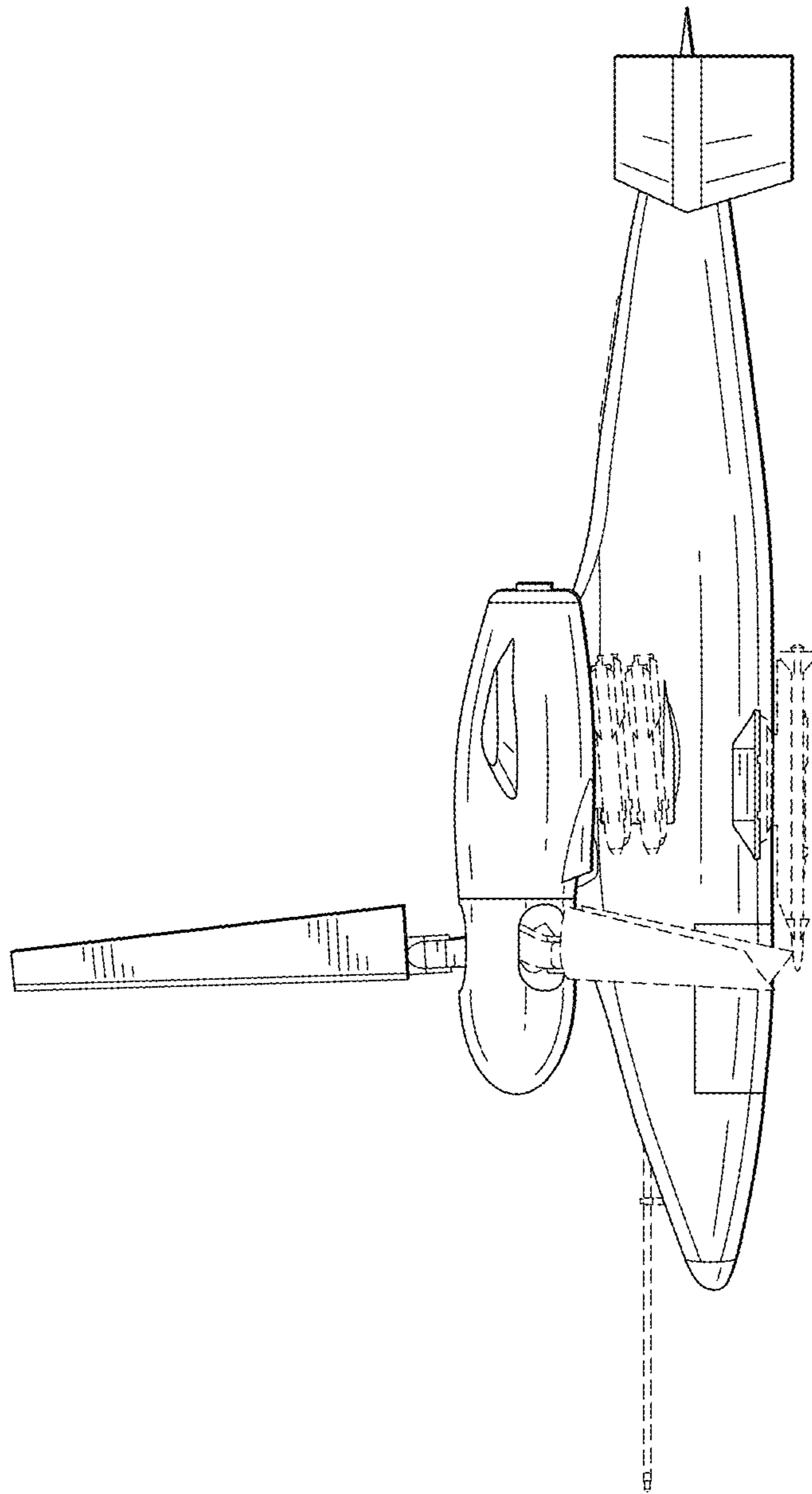

FIG. 18

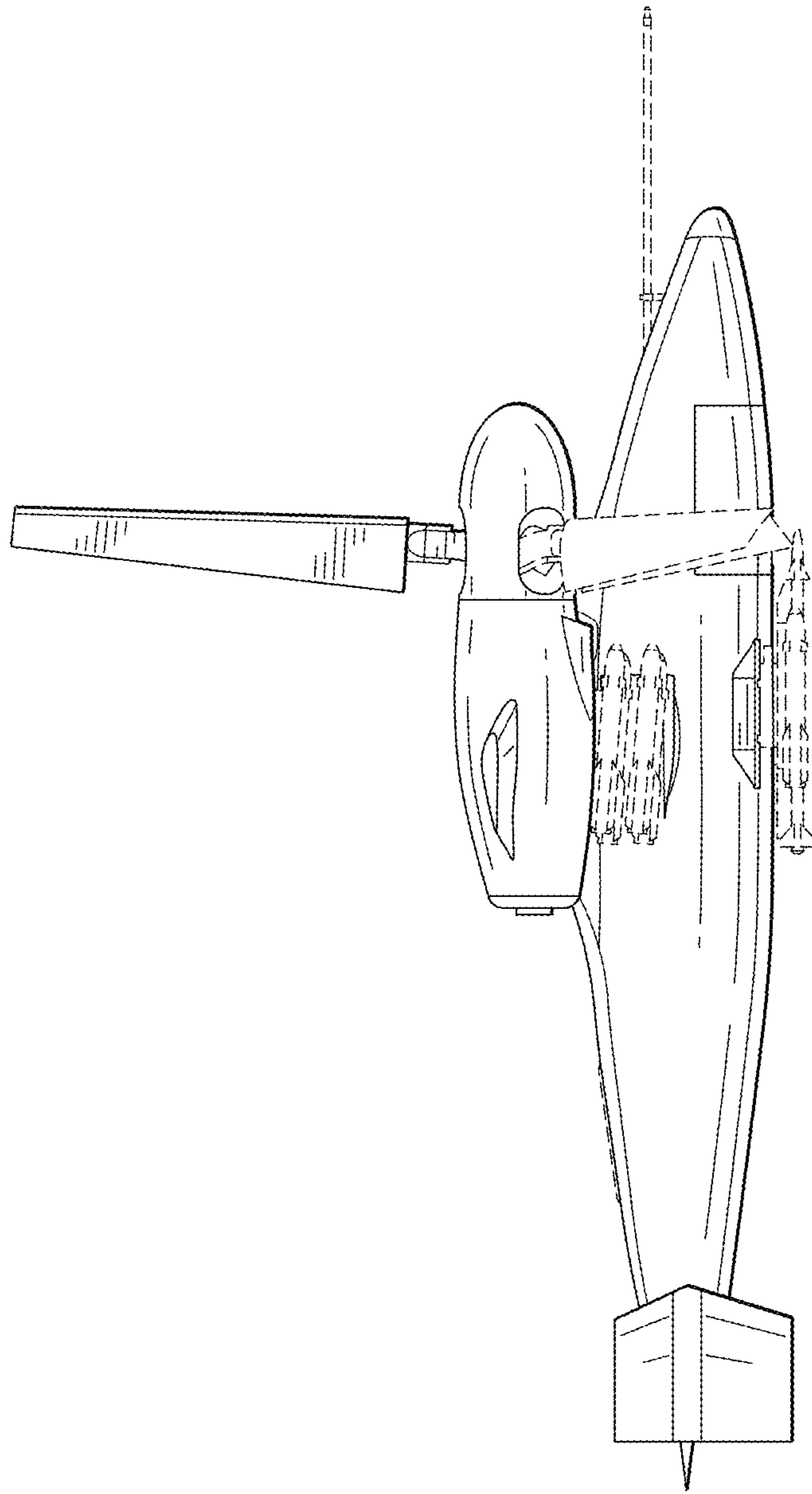

FIG. 19

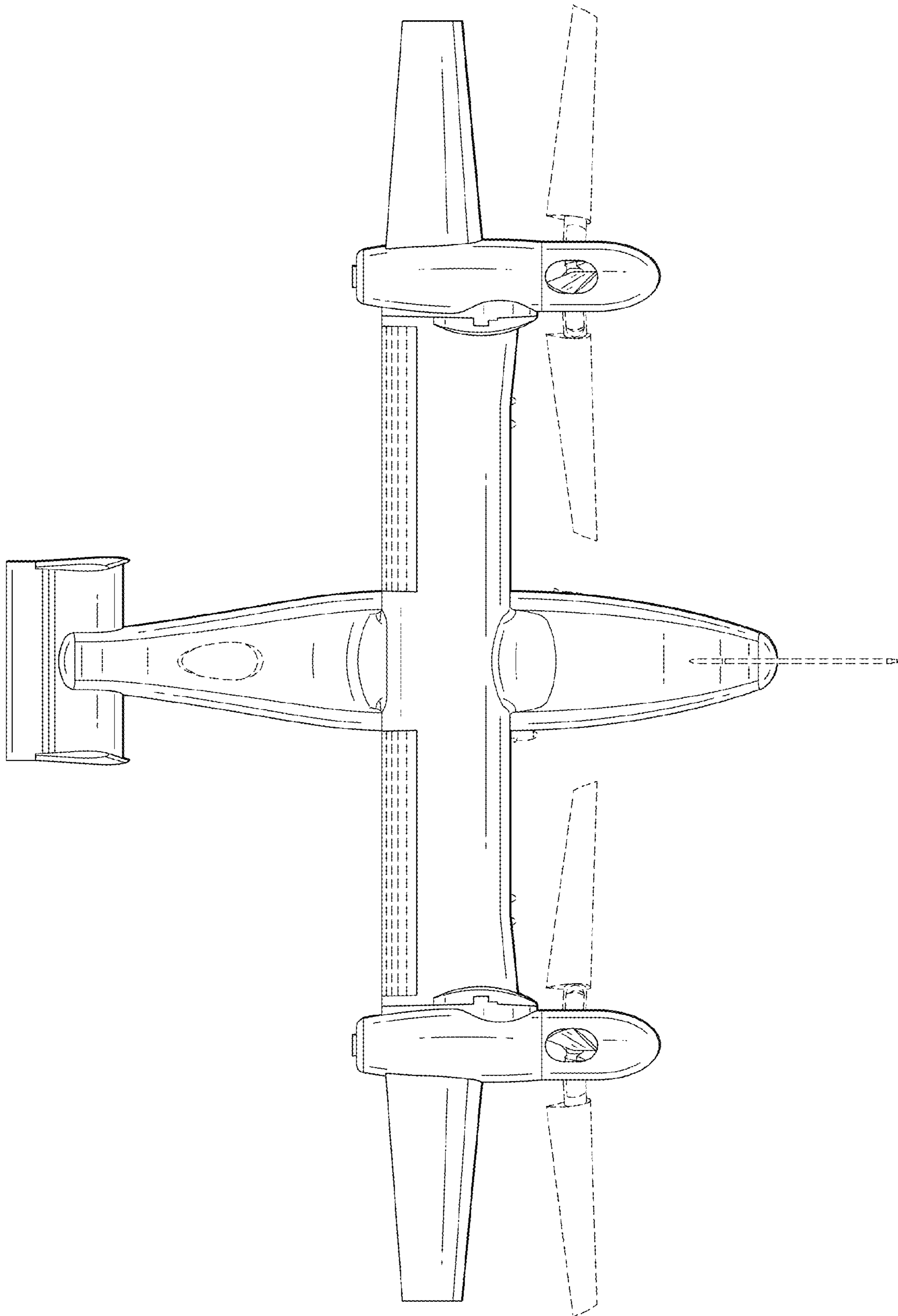

FIG. 20

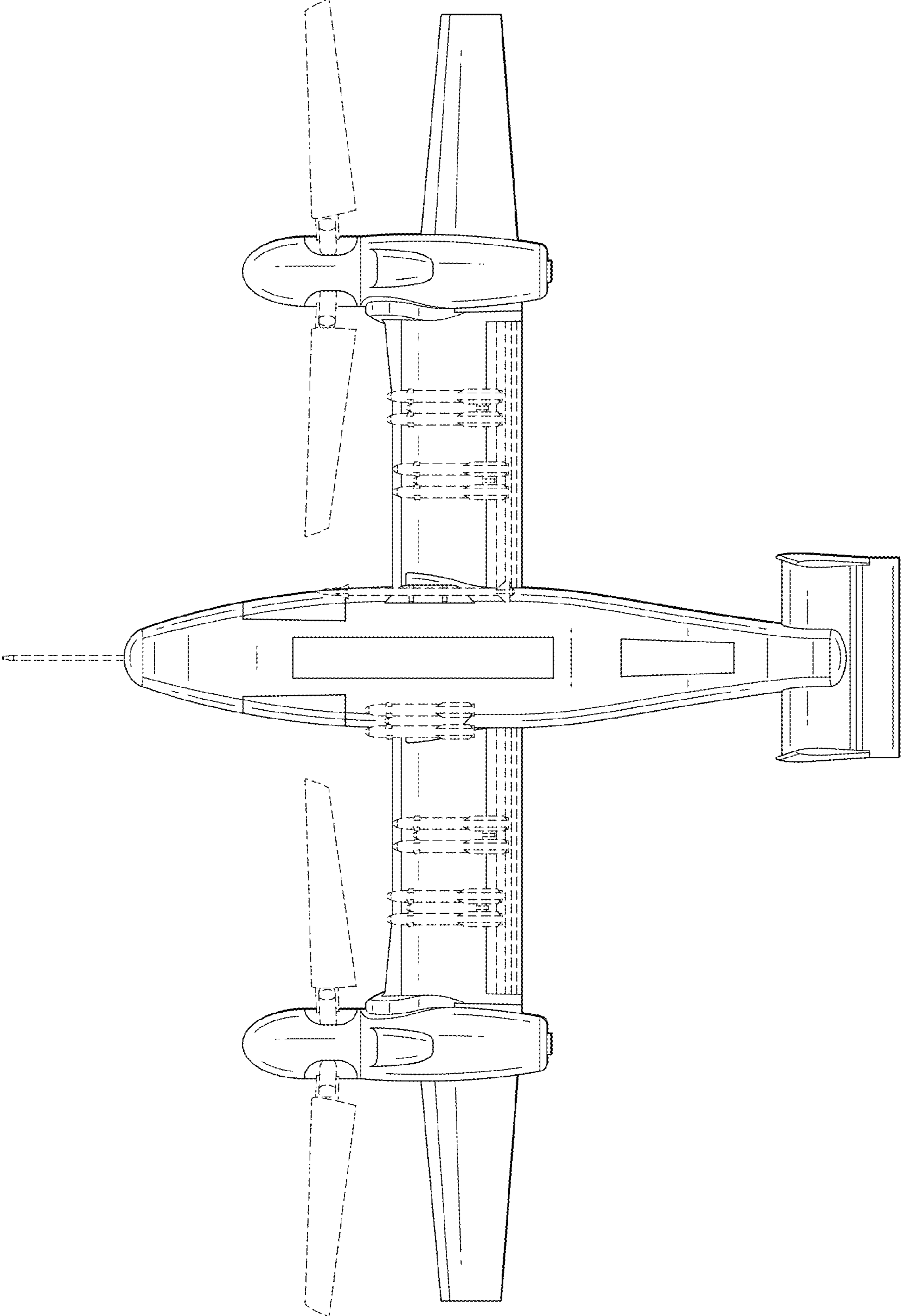

FIG. 21

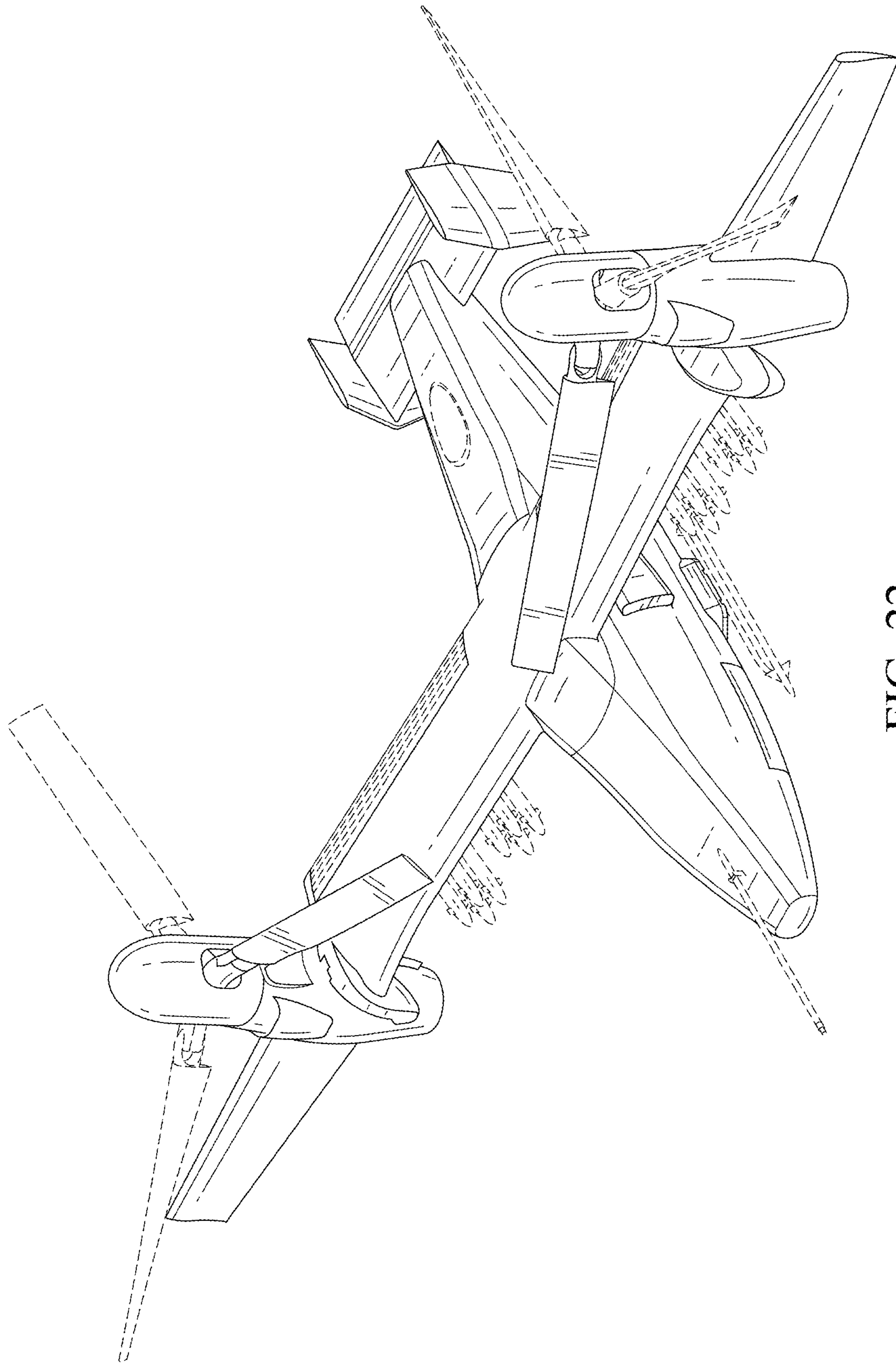

FIG. 22

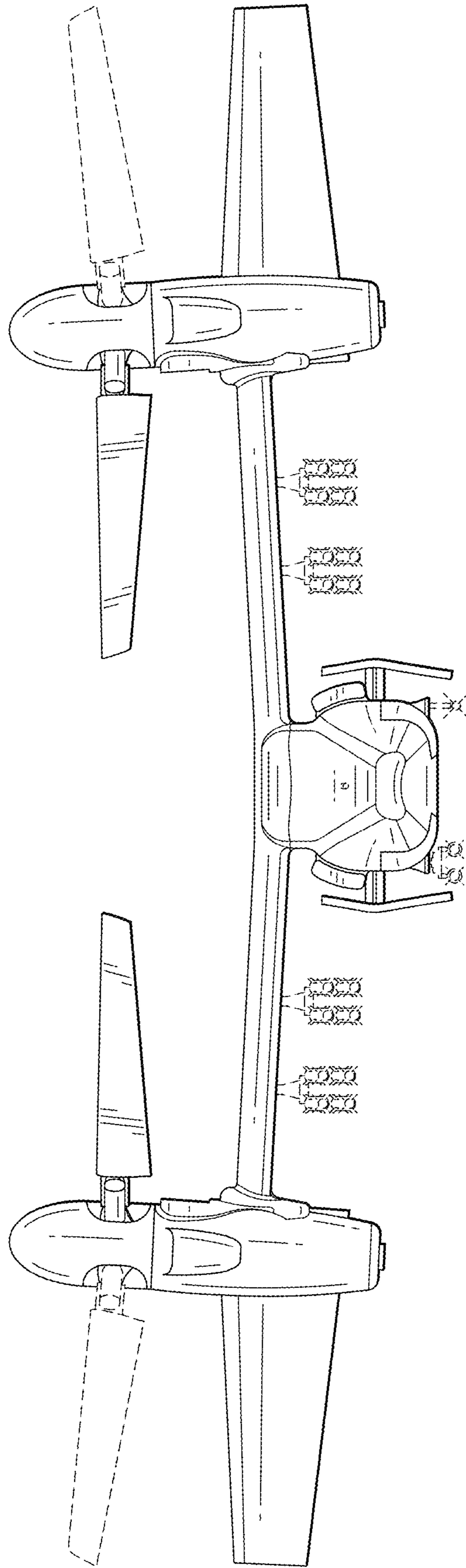

FIG. 23

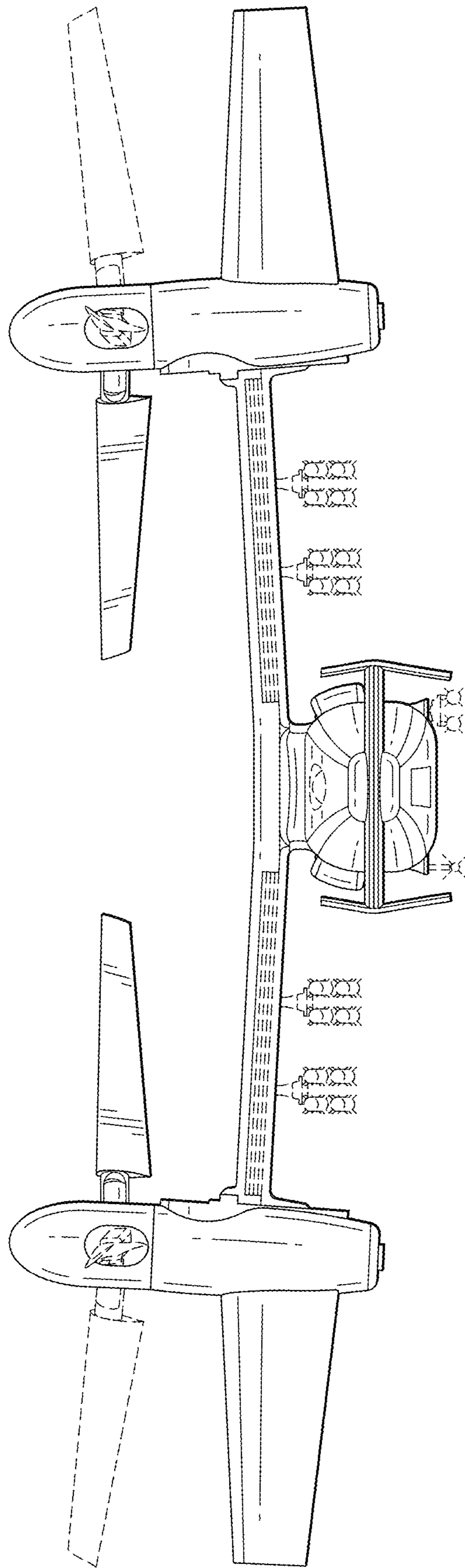

FIG. 24

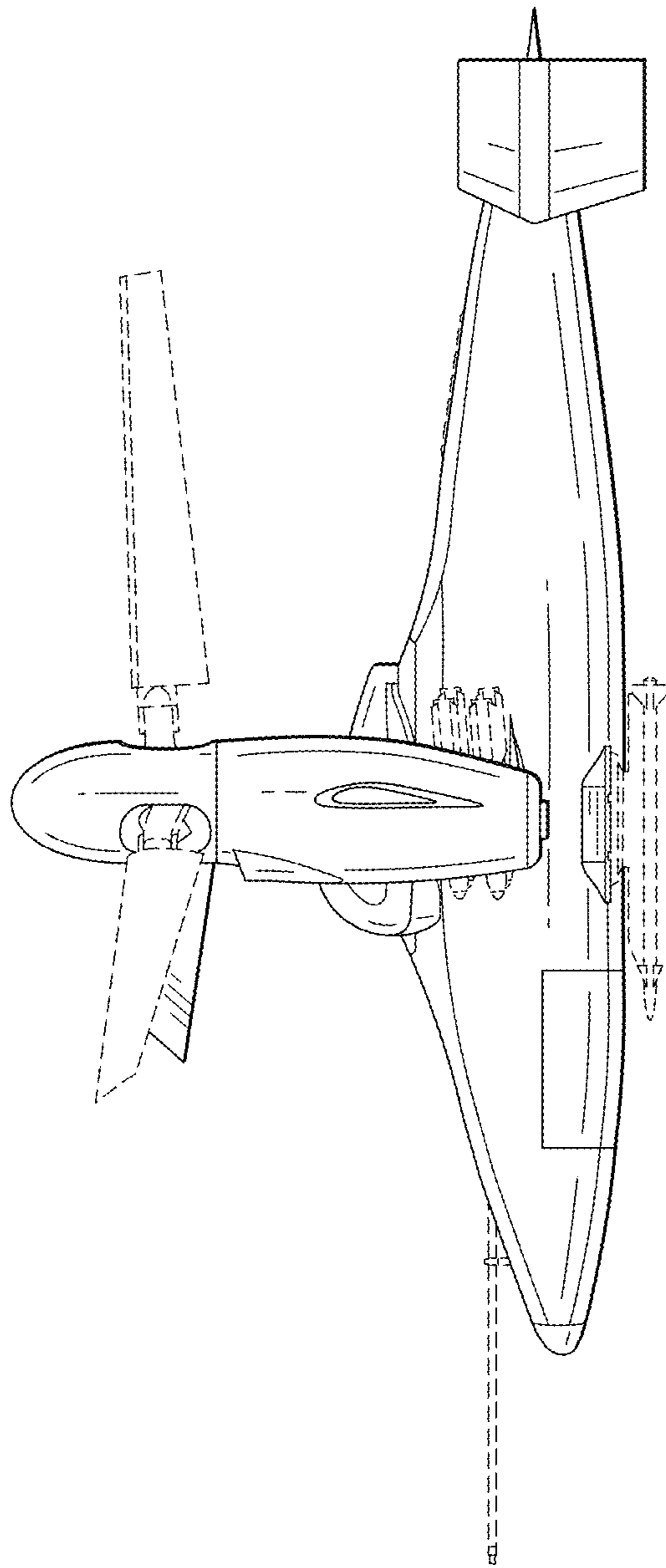

FIG. 25

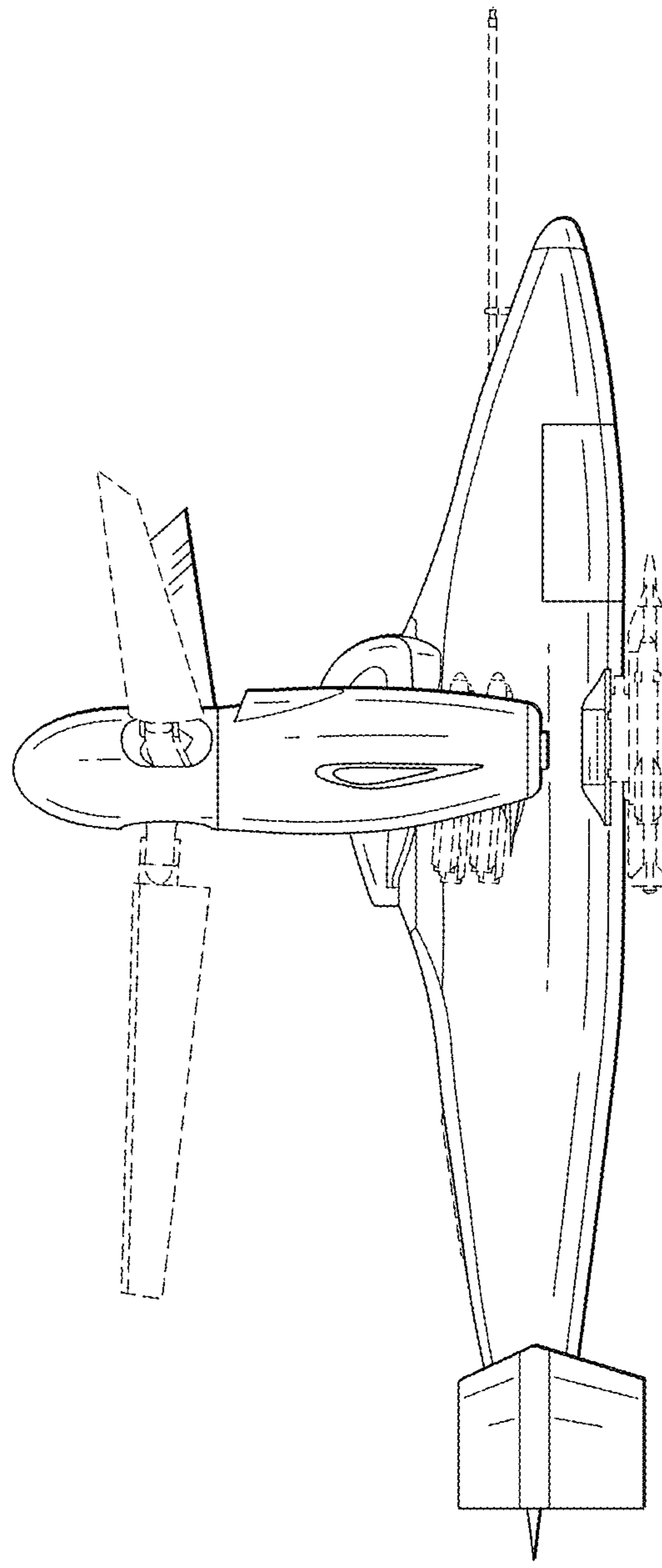

FIG. 26

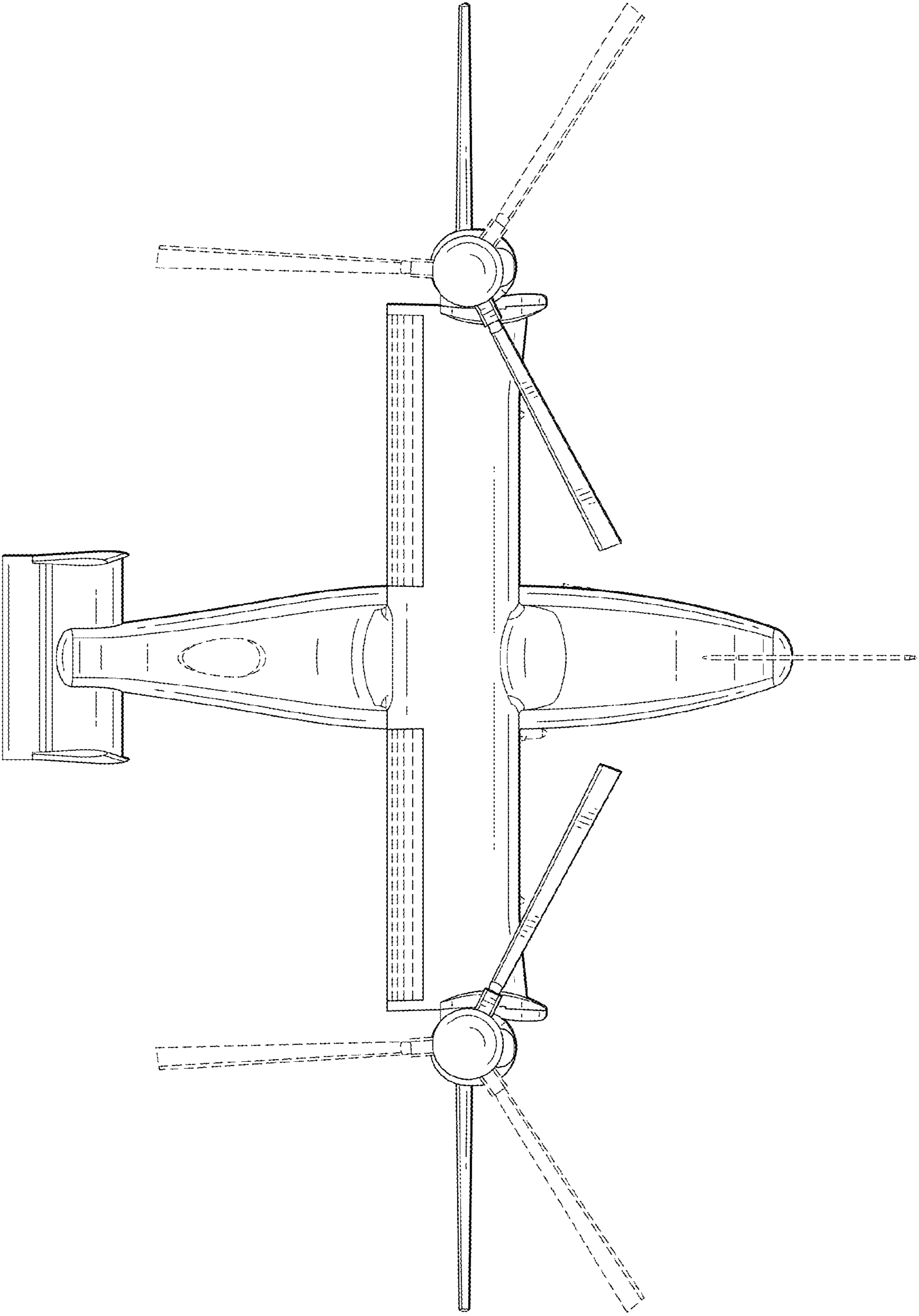

FIG. 27

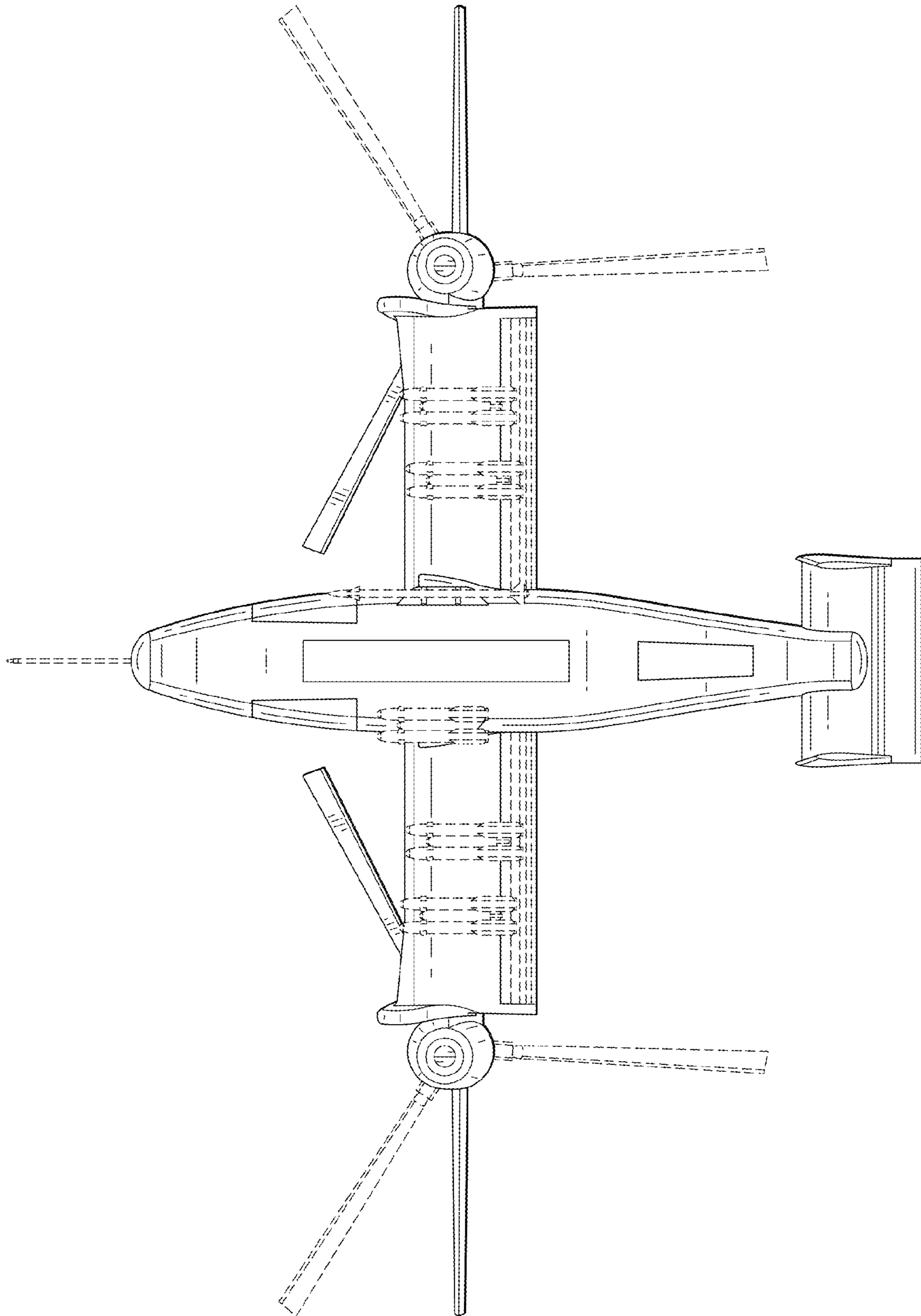

FIG. 28