



US00D909934S

(12) **United States Design Patent** (10) **Patent No.:** **US D909,934 S**
Gander et al. (45) **Date of Patent:** **** Feb. 9, 2021**

(54) **VEHICLE HOOD**

(56) **References Cited**

- (71) Applicant: **Oshkosh Corporation**, Oshkosh, WI (US)
- (72) Inventors: **Jesse Gander**, Larsen, WI (US);
Christopher Yakes, Oshkosh, WI (US)
- (73) Assignee: **Oshkosh Corporation**, Oshkosh, WI (US)
- (**) Term: **15 Years**
- (21) Appl. No.: **29/735,597**
- (22) Filed: **May 22, 2020**

U.S. PATENT DOCUMENTS

1,001,863 A 8/1911 Kirkwood
 1,278,460 A 9/1918 Hanger
 (Continued)

FOREIGN PATENT DOCUMENTS

CA 2478228 A1 2/2006
 DE 11 86 334 1/1965
 (Continued)

OTHER PUBLICATIONS

U.S. Appl. No. 10/171,075, filed Jun. 13, 2002, Archer et al.
 (Continued)

Related U.S. Application Data

- (63) Continuation of application No. 29/706,533, filed on Sep. 20, 2019, which is a continuation of application No. 29/680,745, filed on Feb. 19, 2019, now Pat. No. Des. 871,283, which is a continuation of application No. 29/621,958, filed on Oct. 12, 2017, now Pat. No. Des. 843,281, which is a continuation of application No. 14/612,100, filed on Feb. 2, 2015, now Pat. No. 9,829,282, which is a continuation of application No. 13/629,009, filed on Sep. 27, 2012, now Pat. No. 8,943,946, said application No. 29/621,958 is a continuation of application No. 15/599,174, filed on
 (Continued)

(51) **LOC (13) Cl.** **12-08**

(52) **U.S. Cl.**
USPC **D12/173**

(58) **Field of Classification Search**
 USPC D12/86, 91, 93, 163, 164, 165, 166, 167,
 D12/169, 171, 172, 173, 190, 216
 CPC B60R 9/06; B60R 19/02; B60R 19/04;
 B60R 19/18; B60R 19/44; B60R 19/48;
 B62D 35/02; B62D 39/00; B62D 65/16;
 B62D 21/12; B29C 45/16

See application file for complete search history.

Primary Examiner — Janice Hallmark
Assistant Examiner — Suzanne E Tisdell
 (74) *Attorney, Agent, or Firm* — Foley & Lardner LLP

(57) **CLAIM**

We claim the ornamental design for a vehicle hood, as shown and described.

DESCRIPTION

FIG. 1 is a front perspective view of a vehicle hood showing our new design;
 FIG. 2 is a front view thereof;
 FIG. 3 is a rear view thereof;
 FIG. 4 is a left side view thereof;
 FIG. 5 is a right side view thereof;
 FIG. 6 is a top view thereof;
 FIG. 7 is a bottom view thereof;
 FIG. 8 is a front perspective enlarged detail view thereof; and,
 FIG. 9 is a second front perspective thereof.
 Evenly-spaced broken lines depict unclaimed environmental subject matter. Dash-dot broken lines depict unclaimed boundaries of the claimed design.

1 Claim, 9 Drawing Sheets

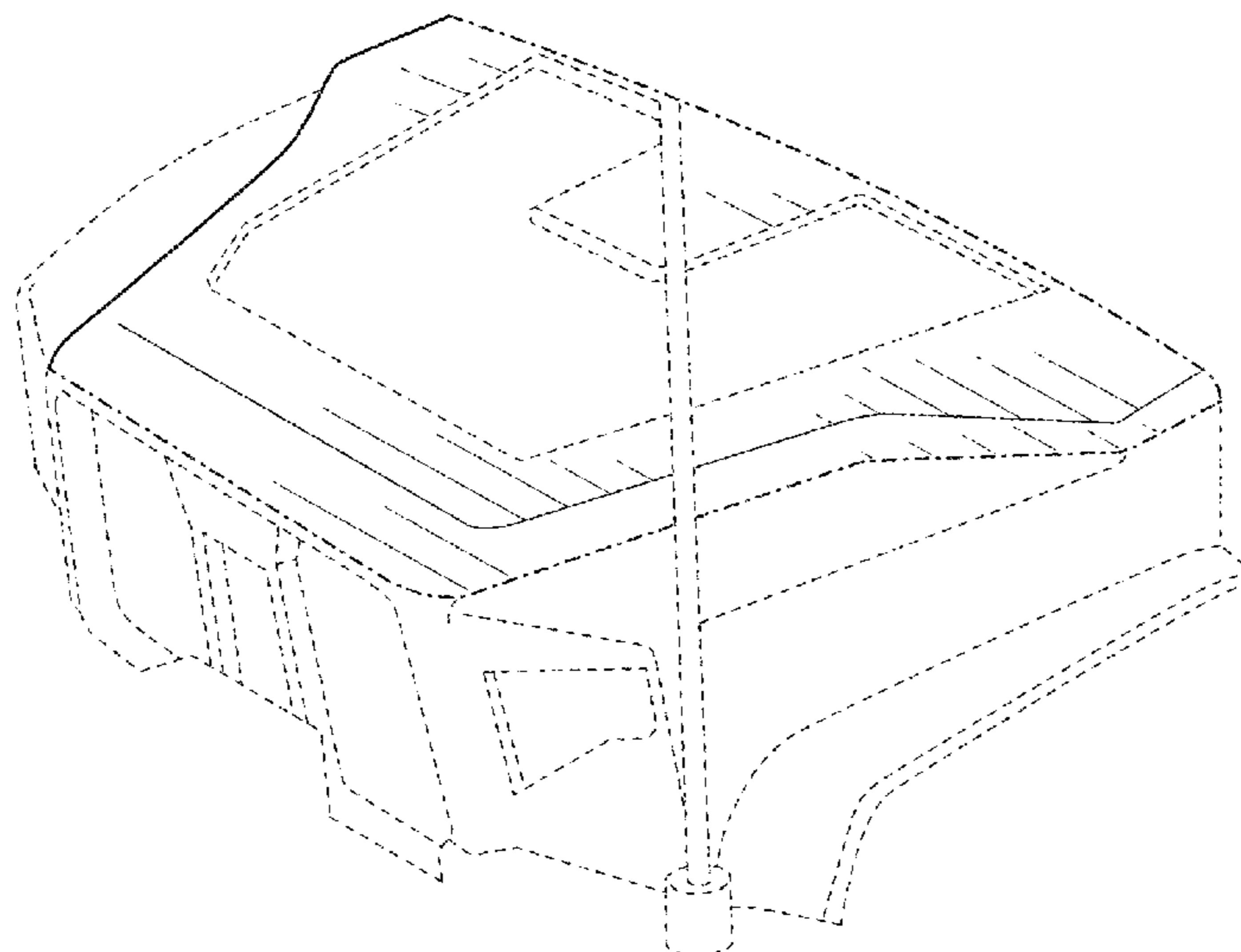

Related U.S. Application Data

May 18, 2017, now Pat. No. 10,434,995, which is a continuation of application No. 14/724,279, filed on May 28, 2015, now Pat. No. 9,656,640, which is a continuation of application No. 13/841,686, filed on Mar. 15, 2013, now Pat. No. 9,045,014.

(56)

References Cited

U.S. PATENT DOCUMENTS

1,376,467 A	5/1921	Simmon	5,113,946 A	5/1992	Cooper
1,463,569 A	7/1923	Bathrick	5,137,101 A	8/1992	Schaeff
1,835,132 A	12/1931	Anania	5,137,292 A	8/1992	Eisen
1,941,582 A	1/1934	Schroeder	5,139,104 A	8/1992	Moscicki
2,628,127 A	2/1953	Palsgrove	5,143,326 A	9/1992	Parks
2,632,577 A	3/1953	Sacco	5,158,614 A	10/1992	Takeuchi
2,907,575 A	10/1959	Locker	5,169,197 A	12/1992	Underbakke et al.
2,915,334 A	12/1959	Barenyi	5,209,003 A	5/1993	Maxfield et al.
2,916,997 A	12/1959	Terrie	5,211,245 A	5/1993	Relyea et al.
2,997,242 A	8/1961	Grosholz	5,217,083 A	6/1993	Bachhuber et al.
3,010,533 A	11/1961	Ross	5,301,756 A	4/1994	Relyea et al.
3,021,166 A	2/1962	Kempel et al.	5,319,436 A	6/1994	Manns et al.
3,039,788 A	6/1962	Farago	5,322,321 A	6/1994	Yopp
3,046,045 A	7/1962	Campbell	5,327,989 A	7/1994	Furuhashi et al.
3,083,790 A	4/1963	McAfee et al.	5,346,334 A	9/1994	Einaru et al.
3,131,963 A	5/1964	Schilberg	5,368,317 A	11/1994	McCombs et al.
3,146,839 A	9/1964	Carlson	5,390,945 A	2/1995	Orr
3,188,966 A	6/1965	Tetlow	5,438,908 A	8/1995	Madden, Jr.
3,306,390 A	2/1967	Jamme	5,467,827 A	11/1995	McLoughlin
3,395,672 A	8/1968	Ruf	5,487,323 A	1/1996	Madden, Jr.
3,500,961 A	3/1970	Eberhardt et al.	5,501,288 A	3/1996	Ducote
3,590,948 A	7/1971	Milner, Jr.	5,533,781 A	7/1996	Williams
3,726,308 A	4/1973	Eberhardt	5,538,185 A	7/1996	Rabitsch et al.
3,881,767 A	5/1975	Klees	5,538,274 A	7/1996	Schmitz et al.
4,037,664 A	7/1977	Gibson	5,553,673 A	9/1996	Hackman
4,059,170 A	11/1977	Young	5,617,696 A	4/1997	Young
4,084,522 A	4/1978	Younger	5,663,520 A	9/1997	Ladika et al.
4,103,757 A	8/1978	McVaugh	5,670,734 A	9/1997	Middione et al.
4,153,262 A	5/1979	Diamond et al.	5,679,918 A	10/1997	Korpi et al.
4,157,733 A	6/1979	Ewers et al.	5,687,669 A	11/1997	Engler
4,160,492 A	7/1979	Johnston	5,716,066 A	2/1998	Chou et al.
4,185,924 A	1/1980	Graham	5,746,396 A	5/1998	Thorton-Trump
4,241,803 A	12/1980	Lauber	5,752,862 A	5/1998	Mohler et al.
4,270,771 A	6/1981	Fujii	5,785,372 A	7/1998	Glatzmeier et al.
4,326,445 A	4/1982	Bemiss	5,788,158 A	8/1998	Relyea
4,329,109 A	5/1982	Den Bleyker	5,794,966 A	8/1998	MacLeod
4,337,830 A	7/1982	Eberhardt	5,807,056 A	9/1998	Osborn et al.
4,369,010 A	1/1983	Ichinose et al.	5,820,150 A	10/1998	Archer et al.
4,373,600 A	2/1983	Buschbom et al.	D400,835 S	11/1998	Le Quement et al.
4,395,191 A	7/1983	Kaiser	5,836,657 A	11/1998	Tilley et al.
4,456,093 A	6/1984	Finley et al.	5,839,664 A	11/1998	Relyea
4,492,282 A	1/1985	Appelblatt et al.	RE36,196 E	4/1999	Eberhardt
4,558,758 A	12/1985	Littman et al.	5,897,123 A	4/1999	Cherney et al.
4,563,124 A	1/1986	Eskew	5,899,276 A	5/1999	Relyea et al.
4,586,743 A	5/1986	Edwards et al.	5,900,199 A	5/1999	Dickson et al.
4,587,862 A	5/1986	Hoffman	5,905,225 A	5/1999	Joynt
4,655,307 A	4/1987	Lamoureux	5,909,780 A	6/1999	De Andrade
4,659,104 A	4/1987	Tanaka et al.	5,915,728 A	6/1999	Blackburn
4,669,744 A	6/1987	Sano et al.	5,915,775 A	6/1999	Martin et al.
4,696,489 A	9/1987	Fujishiro et al.	5,919,240 A	7/1999	Ney et al.
4,709,358 A	11/1987	Appling et al.	5,954,364 A	9/1999	Nechushtan
4,733,876 A	3/1988	Heider et al.	6,009,953 A	1/2000	Laskaris et al.
4,811,804 A	3/1989	Ewers et al.	6,015,155 A	1/2000	Brookes et al.
4,826,141 A	5/1989	Buma et al.	6,036,201 A	3/2000	Pond et al.
4,834,418 A	5/1989	Buma et al.	6,105,984 A	8/2000	Schmitz et al.
4,926,954 A	5/1990	Ataka et al.	6,109,684 A	8/2000	Reitnauer
4,945,780 A	8/1990	Bosma	6,131,685 A	10/2000	Sakamoto et al.
5,004,156 A	4/1991	Montanier	6,155,351 A	12/2000	Breedlove et al.
5,010,971 A	4/1991	Hamada et al.	6,178,746 B1	1/2001	Thoma et al.
5,021,917 A	6/1991	Pike et al.	6,220,532 B1	4/2001	Manon et al.
5,028,088 A	7/1991	Del Monico et al.	6,231,466 B1	5/2001	Thoma et al.
5,040,823 A	8/1991	Lund	6,270,098 B1	8/2001	Heyring et al.
5,054,806 A	10/1991	Chester	6,270,153 B1	8/2001	Toyao et al.
5,076,597 A	12/1991	Korekane et al.	6,289,995 B1	9/2001	Fuller
5,080,392 A	1/1992	Bazergui	6,311,795 B1	11/2001	Skotnikov et al.
5,111,901 A	5/1992	Bachhuber et al.	6,318,742 B2	11/2001	Franzini
			6,357,769 B1	3/2002	Omundson et al.
			6,394,007 B2	5/2002	Lewis et al.
			6,394,534 B1	5/2002	Dean
			6,398,236 B1	6/2002	Richardson
			6,398,478 B2	6/2002	Smith et al.
			6,421,593 B1	7/2002	Kempen et al.
			6,435,071 B1	8/2002	Campbell
			6,435,298 B1	8/2002	Mizuno et al.
			6,443,687 B1	9/2002	Kaiser
			6,460,907 B2	10/2002	Usui
			6,503,035 B1	1/2003	Perrott
			6,516,914 B1	2/2003	Andersen et al.
			6,520,494 B1	2/2003	Andersen et al.

(56)

References Cited

U.S. PATENT DOCUMENTS

6,527,494 B2	3/2003	Hurlburt	7,425,891 B2	9/2008	Colburn et al.	
D473,829 S	4/2003	Hoyle, Jr.	7,439,711 B2	10/2008	Bolton	
6,553,290 B1	4/2003	Pillar	7,441,615 B2	10/2008	Borroni-Bird et al.	
6,561,718 B1	5/2003	Archer et al.	7,441,809 B1	10/2008	Coombs et al.	
6,619,673 B2	9/2003	Eckelberry et al.	7,448,460 B2	11/2008	Morrow et al.	
6,623,020 B1	9/2003	Satou	7,451,028 B2	11/2008	Pillar et al.	
6,658,984 B2	12/2003	Zonak	7,472,914 B2	1/2009	Anderson et al.	
6,692,366 B1	2/2004	Savant	7,472,919 B2	1/2009	Pratt et al.	
6,695,328 B2	2/2004	Cope	7,510,235 B2	3/2009	Kobayashi et al.	
6,702,058 B2	3/2004	Ishii et al.	7,520,354 B2	4/2009	Morrow et al.	
6,736,232 B1	5/2004	Bergstrom et al.	7,522,979 B2	4/2009	Pillar	
6,757,597 B2	6/2004	Yakes et al.	7,555,369 B2	6/2009	Pillar et al.	
6,764,085 B1	7/2004	Anderson	D597,002 S	7/2009	Jamieson et al.	
6,769,733 B2	8/2004	Seksaria et al.	7,594,561 B2	9/2009	Hass et al.	
6,779,806 B1	8/2004	Breitbach et al.	7,611,153 B2	11/2009	Kim et al.	
6,820,908 B1	11/2004	Tousi et al.	7,611,154 B2	11/2009	Delaney	
6,848,693 B2	2/2005	Schneider	7,618,063 B2	11/2009	Takeshima et al.	
6,860,332 B1	3/2005	Archer et al.	7,624,835 B2	12/2009	Bowers	
6,882,917 B2	4/2005	Pillar et al.	7,624,995 B2	12/2009	Barbison	
6,883,815 B2	4/2005	Archer	7,681,892 B1	3/2010	Crews et al.	
6,885,920 B2	4/2005	Yakes et al.	7,689,332 B2	3/2010	Yakes et al.	
6,899,191 B1	5/2005	Lykken	7,695,053 B1	4/2010	Boczek et al.	
6,909,944 B2	6/2005	Pillar et al.	7,699,385 B2	4/2010	Kurata	
6,922,615 B2	7/2005	Pillar et al.	7,711,460 B2	5/2010	Yakes et al.	
6,923,453 B2	8/2005	Pivac	7,715,962 B2	5/2010	Rowe et al.	
6,925,735 B2	8/2005	Hamm et al.	7,725,225 B2	5/2010	Pillar et al.	
6,959,466 B2	11/2005	Alowonle et al.	D617,255 S	6/2010	Tezak et al.	
6,976,688 B2	12/2005	Archer et al.	7,726,429 B2	6/2010	Suzuki	
6,993,421 B2	1/2006	Pillar et al.	7,729,831 B2	6/2010	Pillar et al.	
7,006,902 B2	2/2006	Archer et al.	D619,062 S	7/2010	Improta	
7,024,296 B2	4/2006	Squires et al.	7,756,621 B2	7/2010	Pillar et al.	
7,072,745 B2	7/2006	Pillar et al.	7,757,805 B2	7/2010	Wakuta et al.	
7,073,620 B2	7/2006	Braun et al.	7,770,506 B2	8/2010	Johnson et al.	
D528,482 S	9/2006	Hamburger	D623,100 S	9/2010	Bimbi	
7,107,129 B2	9/2006	Rowe et al.	7,789,010 B2	9/2010	Allor et al.	
7,114,764 B1	10/2006	Barsoum et al.	7,792,618 B2	9/2010	Quigley et al.	
7,127,331 B2	10/2006	Pillar et al.	7,802,816 B2	9/2010	McGuire	
D533,485 S	12/2006	Schiavone et al.	D627,686 S *	11/2010	Thompson	D12/91
7,144,039 B2	12/2006	Kawasaki et al.	7,835,838 B2	11/2010	Pillar et al.	
D535,589 S	1/2007	Lau et al.	7,848,857 B2	12/2010	Nasr et al.	
7,162,332 B2	1/2007	Pillar et al.	7,905,534 B2	3/2011	Boczek et al.	
7,164,977 B2	1/2007	Yakes et al.	7,905,540 B2	3/2011	Kiley et al.	
7,184,662 B2	2/2007	Arbel et al.	7,908,959 B2	3/2011	Pavon	
7,184,862 B2	2/2007	Pillar et al.	D636,305 S	4/2011	Alvarez et al.	
7,184,866 B2	2/2007	Squires et al.	7,931,103 B2	4/2011	Morrow et al.	
7,188,893 B2	3/2007	Akasaka	7,934,766 B2	5/2011	Boczek et al.	
7,198,130 B2	4/2007	Schimke	7,938,478 B2	5/2011	Kamimae	
7,198,278 B2	4/2007	Donaldson	D642,099 S	7/2011	Nagao et al.	
7,207,582 B2	4/2007	Siebers et al.	7,997,182 B1	8/2011	Cox	
7,213,872 B2	5/2007	Ronacher et al.	8,000,850 B2	8/2011	Nasr et al.	
7,234,534 B2	6/2007	Froland et al.	D646,203 S *	10/2011	Thompson	D12/91
7,240,906 B2	7/2007	Klees	D646,607 S *	10/2011	Verhee	D12/169
7,246,835 B1	7/2007	Colburn et al.	8,029,021 B2	10/2011	Leonard et al.	
7,254,468 B2	8/2007	Pillar et al.	8,033,208 B2	10/2011	Joynt et al.	
7,258,194 B2	8/2007	Braun et al.	D649,908 S *	12/2011	Mullen	D12/86
7,267,394 B1	9/2007	Mouch et al.	D649,909 S *	12/2011	Mullen	D12/86
7,270,346 B2	9/2007	Rowe et al.	8,095,247 B2	1/2012	Pillar et al.	
7,274,976 B2	9/2007	Rowe et al.	8,096,225 B1	1/2012	Johnson et al.	
7,277,782 B2	10/2007	Yakes et al.	D655,226 S	3/2012	Hanson et al.	
7,281,600 B2	10/2007	Chernoff et al.	8,139,109 B2	3/2012	Schmiedel et al.	
7,302,320 B2	11/2007	Nasr et al.	8,146,477 B2	4/2012	Joynt	
7,306,069 B2	12/2007	Takeshima et al.	8,146,478 B2	4/2012	Joynt et al.	
D561,665 S	2/2008	Thomas et al.	D661,231 S *	6/2012	Galante	D12/163
7,329,161 B2	2/2008	Roering	8,205,703 B2	6/2012	Halliday	
D563,289 S	3/2008	Pfeiffer	D662,865 S	7/2012	Van Braeckel	
7,357,203 B2	4/2008	Morrow et al.	8,333,390 B2	12/2012	Linsmeier et al.	
D568,217 S	5/2008	Tomatsu et al.	8,347,775 B2	1/2013	Altenhof et al.	
7,377,549 B2	5/2008	Hasegawa et al.	8,376,077 B2	2/2013	Venton-Walters	
7,379,797 B2	5/2008	Nasr et al.	8,402,878 B2	3/2013	Schreiner et al.	
7,380,800 B2	6/2008	Klees	8,413,567 B2	4/2013	Luther et al.	
7,392,122 B2	6/2008	Pillar et al.	8,413,568 B2	4/2013	Kosheleff	
7,393,016 B2	7/2008	Mitsui et al.	8,424,443 B2	4/2013	Gonzalez	
7,406,909 B2	8/2008	Shah et al.	8,430,196 B2	4/2013	Halliday	
7,412,307 B2	8/2008	Pillar et al.	D683,675 S *	6/2013	Munson	D12/173
7,419,021 B2	9/2008	Morrow et al.	8,459,619 B2	6/2013	Trinh et al.	
			8,465,025 B2	6/2013	Venton-Walters et al.	
			D686,121 S *	7/2013	McCabe	D12/173
			8,561,735 B2	10/2013	Morrow et al.	
			8,578,834 B2	11/2013	Tunis et al.	

(56)

References Cited

U.S. PATENT DOCUMENTS

8,596,183 B2	12/2013	Coltrane		D860,887 S	9/2019	Gander et al.
8,596,648 B2	12/2013	Venton-Walters et al.		D863,144 S	10/2019	Gander
8,601,931 B2	12/2013	Naroditsky et al.		D864,031 S	10/2019	Gander et al.
8,616,617 B2	12/2013	Sherbeck et al.		D869,332 S	12/2019	Gander et al.
D698,281 S	1/2014	Badstuebner et al.		2001/0015559 A1	8/2001	Storer
D702,615 S	4/2014	Conway et al.		2002/0129696 A1	9/2002	Pek et al.
D703,119 S	4/2014	Platto et al.		2002/0130771 A1	9/2002	Osborne et al.
8,746,741 B2	6/2014	Gonzalez		2002/0153183 A1	10/2002	Puterbaugh et al.
8,764,029 B2	7/2014	Venton-Walters et al.		2002/0190516 A1	12/2002	Henksmeier et al.
8,801,017 B2	8/2014	Ellifson et al.		2003/0001346 A1	1/2003	Hamilton et al.
8,863,884 B2	10/2014	Jacob-Lloyd		2003/0155164 A1	8/2003	Mantini et al.
D718,683 S *	12/2014	Thole	D12/173	2004/0113377 A1	6/2004	Klees
8,905,164 B1	12/2014	Capouellez et al.		2004/0130168 A1	7/2004	O'Connell
8,921,130 B2	12/2014	Kundaliya et al.		2004/0149500 A1	8/2004	Chernoff et al.
8,943,946 B1	2/2015	Richmond et al.		2004/0256024 A1	12/2004	Schlachter
8,944,497 B2	2/2015	Dryselius et al.		2005/0034911 A1	2/2005	Darby
8,947,531 B2	2/2015	Fischer et al.		2005/0062239 A1	3/2005	Shore
8,955,859 B1	2/2015	Richmond et al.		2005/0093265 A1	5/2005	Niaura et al.
8,967,699 B1	3/2015	Richmond et al.		2005/0099885 A1	5/2005	Tamminga
8,991,834 B2	3/2015	Venton-Walters et al.		2005/0110229 A1	5/2005	Kimura et al.
8,991,840 B2	3/2015	Zuleger et al.		2005/0132873 A1	6/2005	Diaz Supisiche et al.
9,016,703 B2	4/2015	Rowe et al.		2005/0161891 A1	7/2005	Trudeau et al.
9,045,014 B1	6/2015	Verhoff et al.		2005/0196269 A1	9/2005	Racer et al.
D735,625 S	8/2015	Mays et al.		2005/0284682 A1	12/2005	Hass et al.
D739,317 S	9/2015	McMahan et al.		2006/0021764 A1	2/2006	Archer et al.
D740,187 S	10/2015	Jamieson		2006/0048986 A1	3/2006	Bracciano
9,156,507 B1	10/2015	Reed		2006/0082079 A1	4/2006	Eichhorn et al.
D743,308 S	11/2015	Hanson et al.		2006/0192354 A1	8/2006	Van Cayzeele
D743,856 S	11/2015	Ma		2006/0201727 A1	9/2006	Chan
9,174,686 B1	11/2015	Messina et al.		2006/0244225 A1	11/2006	Power et al.
9,221,496 B2	12/2015	Barr et al.		2006/0273566 A1	12/2006	Hepner et al.
D749,464 S	2/2016	Giolito		2007/0088469 A1	4/2007	Schmiedel et al.
D754,039 S	4/2016	Behmer et al.		2007/0102963 A1	5/2007	Frederick et al.
9,328,986 B1	5/2016	Pennau et al.		2007/0120334 A1	5/2007	Holbrook
D762,148 S	7/2016	Platto et al.		2007/0145816 A1	6/2007	Gile
9,409,471 B2	8/2016	Hoppe et al.		2007/0158920 A1	7/2007	Delaney
D765,566 S	9/2016	Vena et al.		2007/0186762 A1	8/2007	Dehart et al.
D769,160 S	10/2016	Platto et al.		2007/0234896 A1	10/2007	Joynt
D772,768 S	11/2016	Chiang		2007/0246902 A1	10/2007	Trudeau et al.
D774,994 S	12/2016	Aleman et al.		2008/0017426 A1	1/2008	Walters et al.
D775,021 S *	12/2016	Harriton	D12/173	2008/0017434 A1	1/2008	Harper et al.
D777,220 S	1/2017	Powell		2008/0034953 A1	2/2008	Barbe et al.
D777,615 S	1/2017	Hanson et al.		2008/0053739 A1	3/2008	Chernoff et al.
D778,217 S *	2/2017	Ito	D12/173	2008/0066613 A1	3/2008	Mills et al.
D784,219 S *	4/2017	Jung	D12/173	2008/0099213 A1	5/2008	Morrow et al.
D787,993 S *	5/2017	McCabe	D12/173	2008/0252025 A1	10/2008	Plath
9,650,005 B2	5/2017	Patelczyk et al.		2008/0284118 A1	11/2008	Venton-Walters et al.
9,656,640 B1	5/2017	Verhoff et al.		2009/0001761 A1	1/2009	Yasuhara et al.
D789,840 S	6/2017	Curic et al.		2009/0061702 A1	3/2009	March
D790,409 S	6/2017	Baste		2009/0174158 A1	7/2009	Anderson et al.
D797,603 S *	9/2017	Noone	D12/91	2010/0019538 A1	1/2010	Kiley et al.
D802,491 S	11/2017	Mainville		2010/0026046 A1	2/2010	Mendoza et al.
D804,372 S *	12/2017	Kozub	D12/173	2010/0032932 A1	2/2010	Hastings
D805,965 S	12/2017	Davis		2010/0123324 A1	5/2010	Shoup et al.
D805,968 S	12/2017	Piscitelli et al.		2010/0163330 A1	7/2010	Halliday
D813,757 S *	3/2018	Kozub	D12/173	2010/0187864 A1	7/2010	Tsuchida
D813,758 S *	3/2018	Gonzales	D12/173	2010/0218667 A1	9/2010	Naroditsky et al.
D815,574 S *	4/2018	Mainville	D12/173	2010/0264636 A1	10/2010	Fausch et al.
D818,885 S	5/2018	Seo		2010/0307328 A1	12/2010	Hoadley et al.
D820,179 S	6/2018	Kladde		2010/0307329 A1	12/2010	Kaswen et al.
D823,182 S	7/2018	Yates		2010/0319525 A1	12/2010	Pavon
D823,183 S	7/2018	Yates		2011/0068606 A1	3/2011	Klimek et al.
D824,294 S	7/2018	Ge et al.		2011/0079134 A1	4/2011	Jacquemont et al.
10,023,243 B2	7/2018	Hines et al.		2011/0079978 A1	4/2011	Schreiner et al.
D824,811 S	8/2018	Mainville		2011/0114409 A1	5/2011	Venton-Walters
D824,814 S	8/2018	Heyde		2011/0120791 A1 *	5/2011	Greenwood
D827,410 S	9/2018	Earley				B60K 11/04 180/68.1
D828,258 S	9/2018	Zipfel		2011/0266838 A1	11/2011	Leopold
D830,242 S	10/2018	Zipfel		2011/0291444 A1	12/2011	Ische
D837,106 S	1/2019	Yang		2011/0314999 A1	12/2011	Luther et al.
D837,702 S	1/2019	Gander et al.		2012/0049570 A1	3/2012	Aizik
D843,281 S	3/2019	Gander et al.		2012/0097019 A1	4/2012	Sherbeck et al.
D853,285 S	7/2019	Yang		2012/0111180 A1	5/2012	Johnson et al.
D856,860 S	8/2019	Gander		2012/0174767 A1	7/2012	Naroditsky et al.
D859,226 S	9/2019	Grooms		2012/0181100 A1	7/2012	Halliday
				2012/0193940 A1	8/2012	Tunis et al.
				2013/0009423 A1	1/2013	Yamamoto et al.
				2013/0093154 A1	4/2013	Cordier et al.
				2013/0153314 A1	6/2013	Niedzwiecki

(56)

References Cited

U.S. PATENT DOCUMENTS

2013/0205984 A1 8/2013 Henker et al.
 2013/0241237 A1 9/2013 Dziuba et al.
 2013/0263729 A1 10/2013 Johnson et al.
 2013/0312595 A1 11/2013 Lee
 2014/0035325 A1 2/2014 Naito et al.
 2014/0060304 A1 3/2014 Harmon et al.
 2014/0151142 A1 6/2014 Hoppe et al.
 2014/0262591 A1 9/2014 Turner et al.
 2015/0224847 A1 8/2015 Rowe et al.
 2015/0283889 A1 10/2015 Agnew
 2016/0047631 A1 2/2016 Berman
 2016/0257360 A1 9/2016 MacKenzie et al.
 2017/0328054 A1 11/2017 Bakken
 2017/0355400 A1 12/2017 Weston
 2018/0326843 A1 11/2018 Danielson et al.
 2019/0185077 A1 6/2019 Smith et al.
 2019/0351883 A1 11/2019 Verhoff et al.

FOREIGN PATENT DOCUMENTS

DE 36 20 603 A1 1/1987
 EP 0 685 382 A1 12/1995
 EP 1 633 619 B1 6/2004
 EP 1 371 391 B1 12/2009
 FR 1471914 A 3/1967
 FR 2380176 A1 9/1978
 GB 2 168 015 6/1986
 GB 2 400 588 A 1/2005
 GB 2 400 589 A 2/2005
 GB 2 400 590 A 3/2005
 HK 1088583 10/2007
 JP 4230421 B2 8/1992

JP 06-037090 5/1994
 JP 2005-007995 A 1/2005
 JP 2005-212698 A 8/2005
 JP 2006-056463 A 3/2006
 WO WO-01/76912 A1 10/2001
 WO WO-03/049987 A2 6/2003
 WO WO-2007/140179 A2 12/2007

OTHER PUBLICATIONS

U.S. Appl. No. 14/532,679, filed Nov. 4, 2014, Oshkosh Corporation.
 U.S. Appl. No. 29/680,745, filed Feb. 19, 2019, Oshkosh Corporation.
 U.S. Appl. No. 29/683,330, filed Mar. 12, 2019, Oshkosh Corporation.
 U.S. Appl. No. 29/683,333, filed Mar. 12, 2019, Oshkosh Corporation.
 U.S. Appl. No. 29/700,665, filed Aug. 5, 2019, Oshkosh Corporation.
 U.S. Appl. No. 29/706,533, filed Sep. 20, 2019, Oshkosh Corporation.
 U.S. Appl. No. 29/706,547, filed Sep. 20, 2019, Oshkosh Corporation.
 U.S. Appl. No. 13/629,009, filed Sep. 27, 2012.
 U.S. Appl. No. 13/841,686, filed Mar. 15, 2013.
 U.S. Appl. No. 14/612,100, filed Feb. 2, 2015.
 U.S. Appl. No. 14/724,279, filed May 28, 2015.
 U.S. Appl. No. 15/599,174, filed May 18, 2017.
 U.S. Appl. No. 29/621,958, filed Oct. 12, 2017.
 U.S. Appl. No. 29/680,745, filed Feb. 19, 2019.
 U.S. Appl. No. 29/706,533, filed Sep. 20, 2019.

* cited by examiner

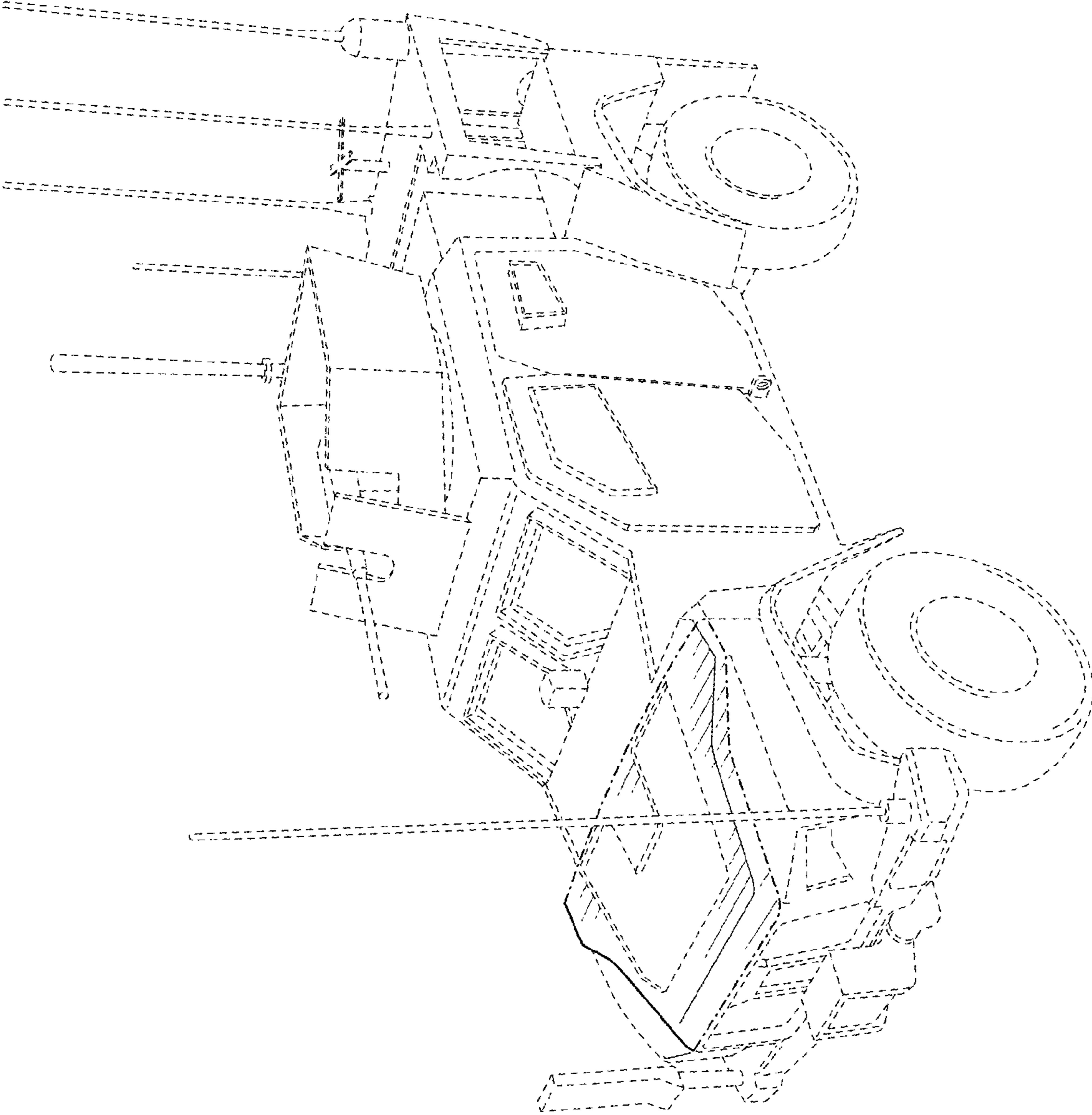

FIG. 1

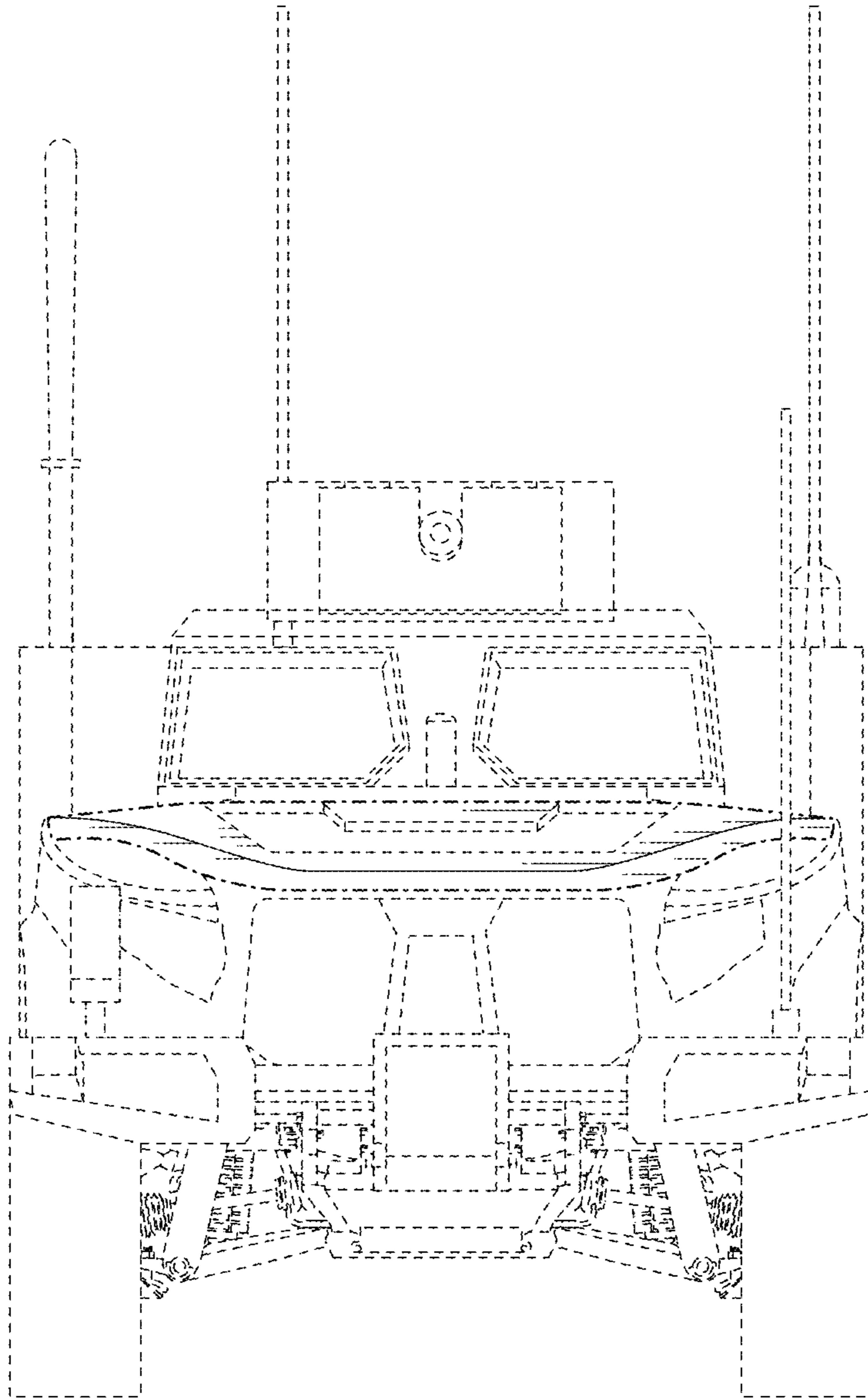

FIG. 2

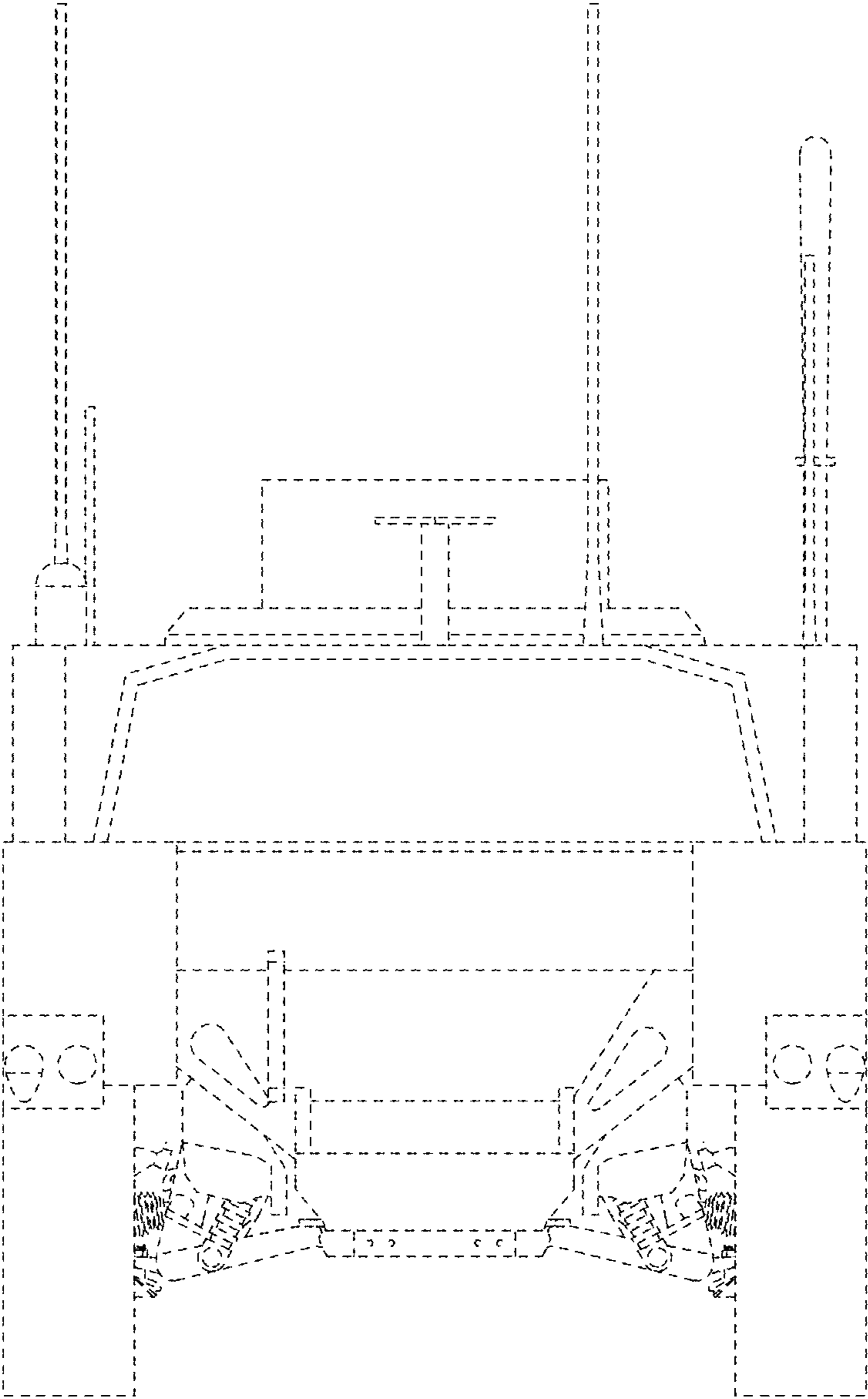

FIG. 3

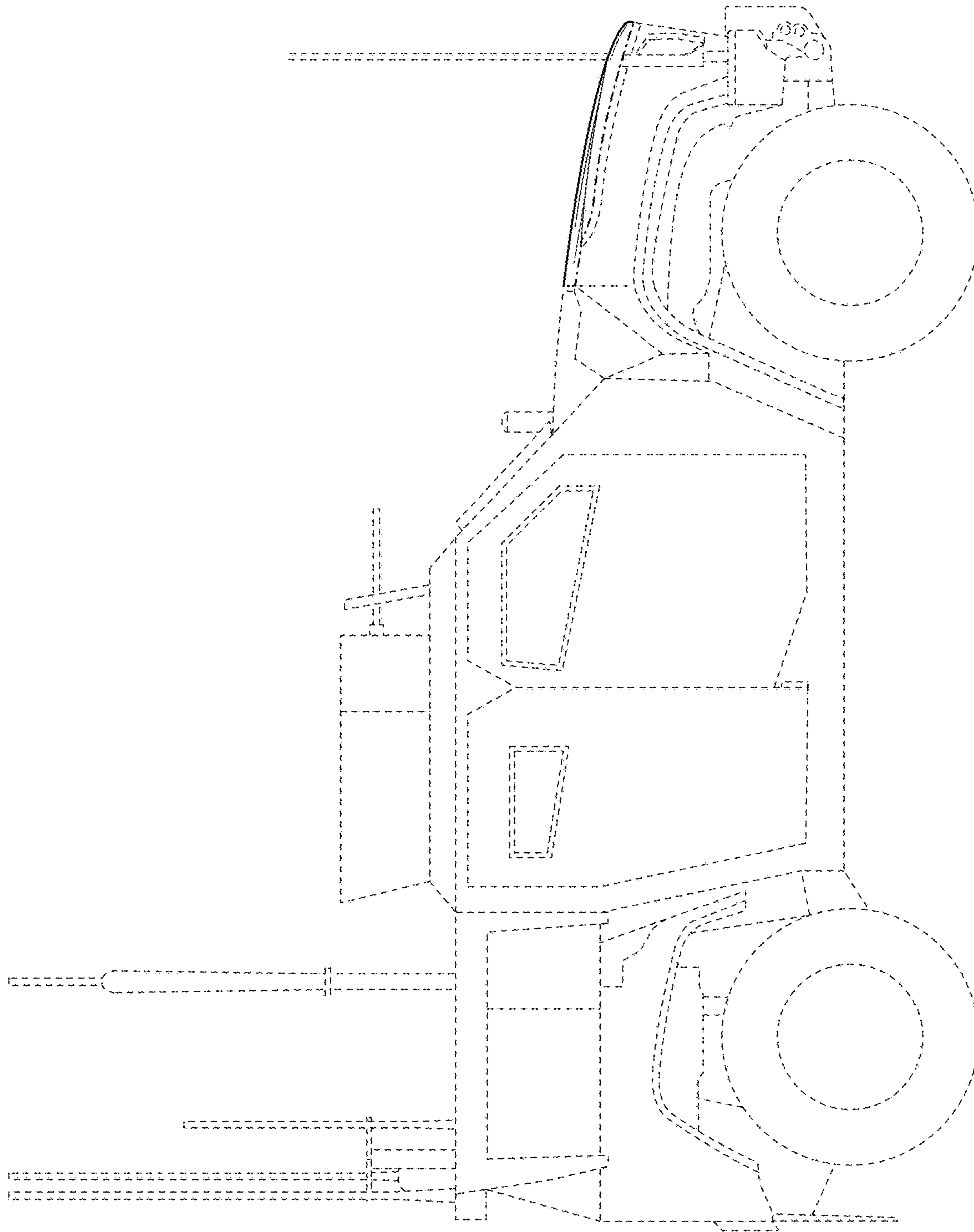

FIG. 4

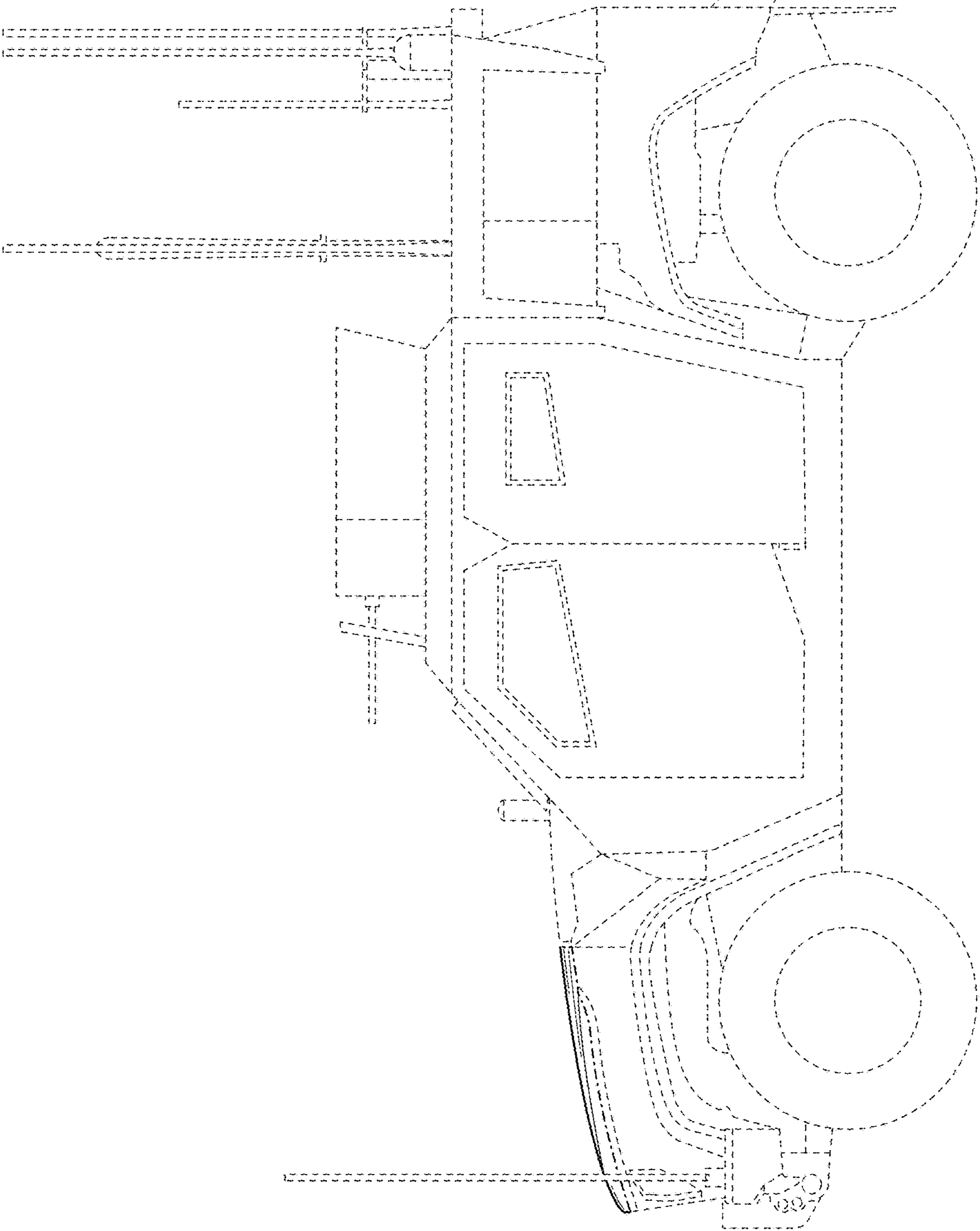

FIG. 5

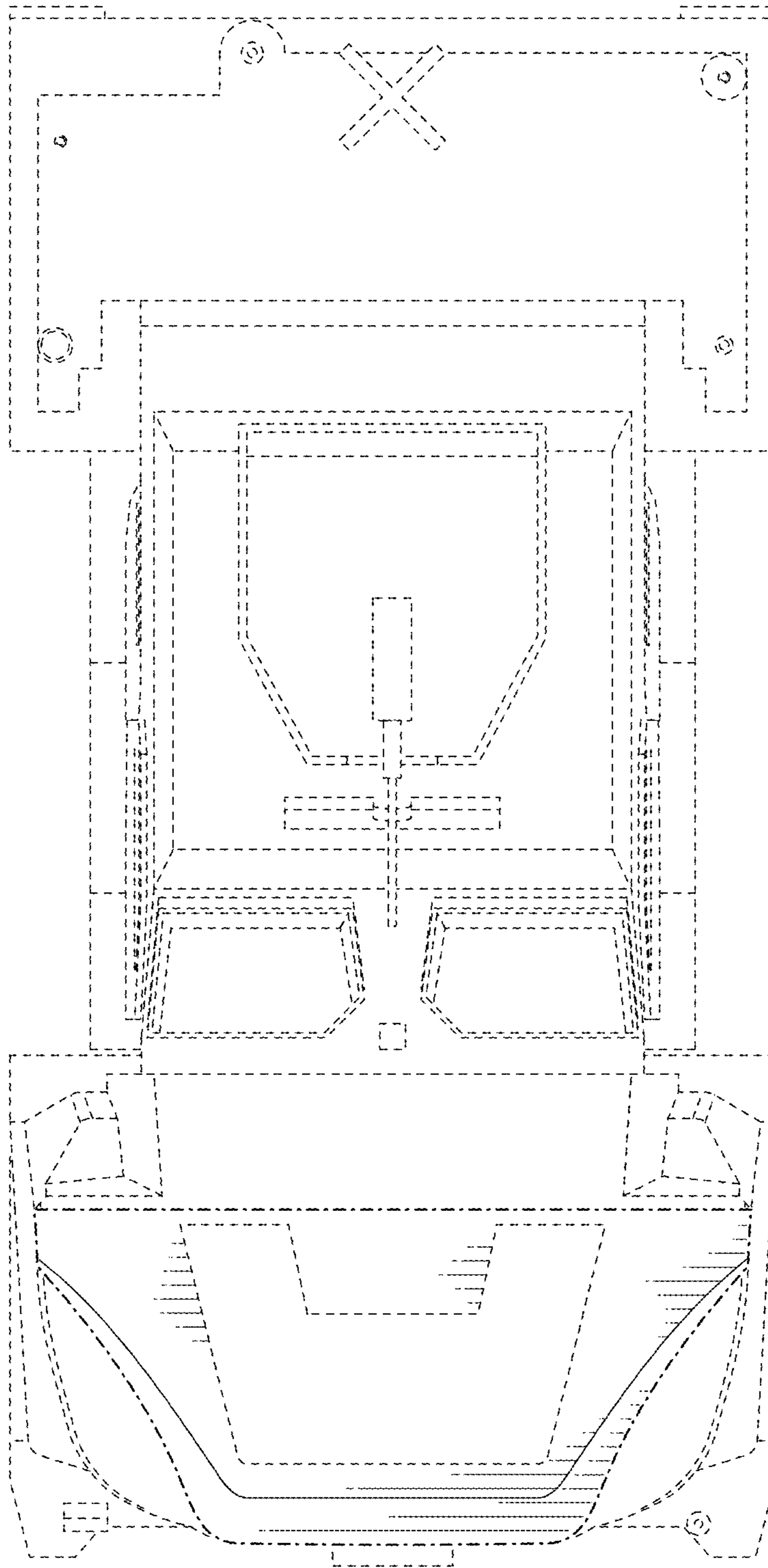

FIG. 6

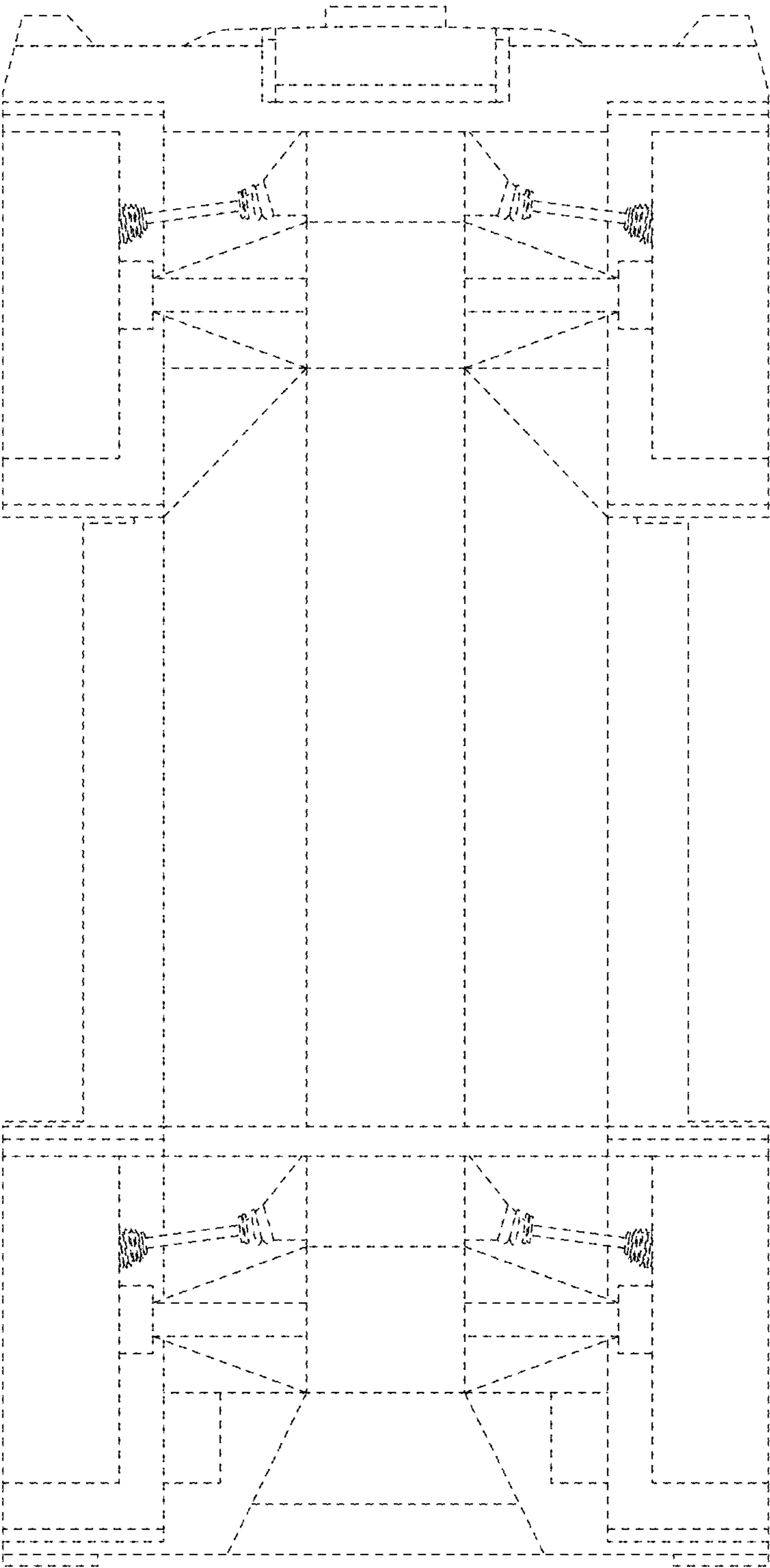

FIG. 7

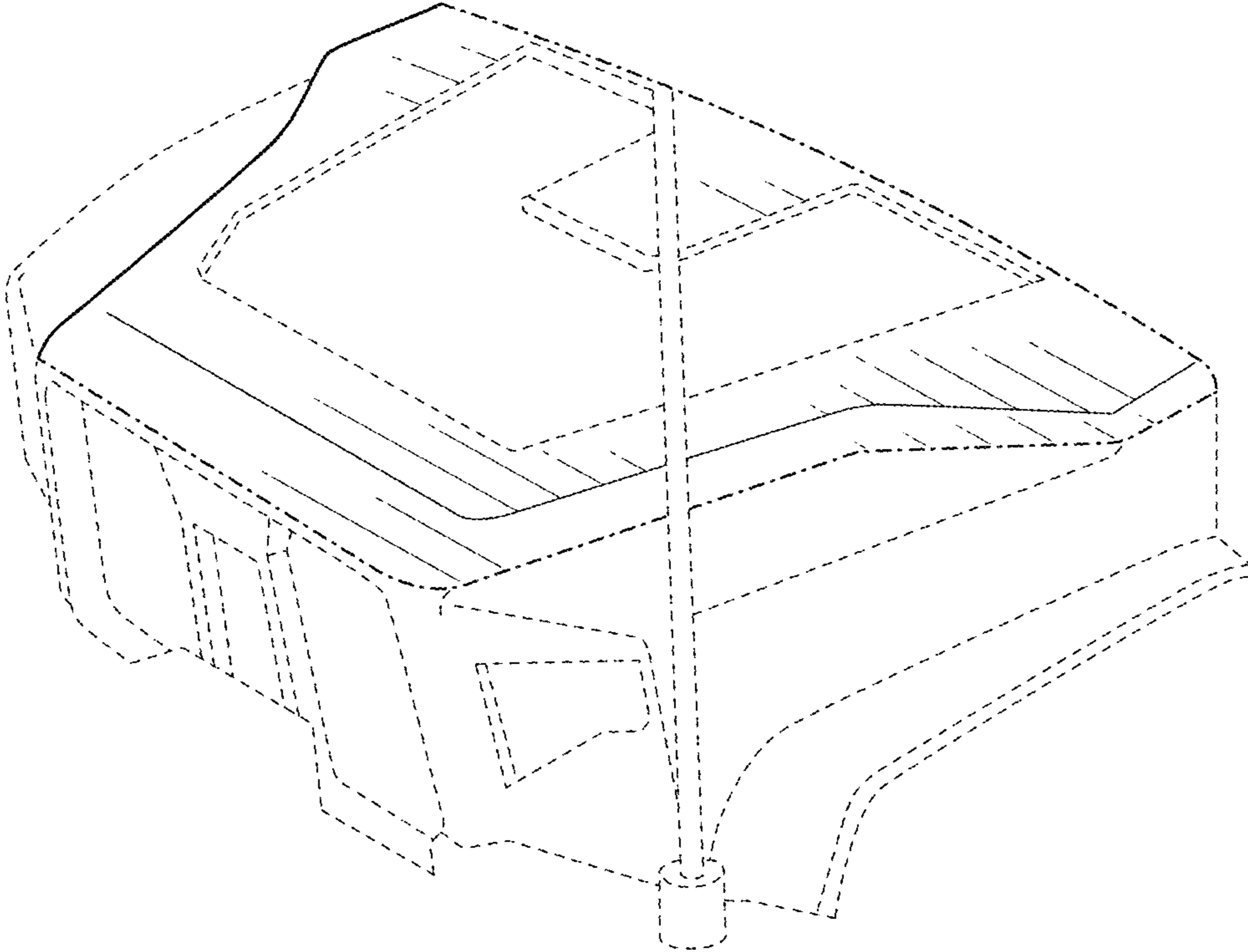

FIG. 8

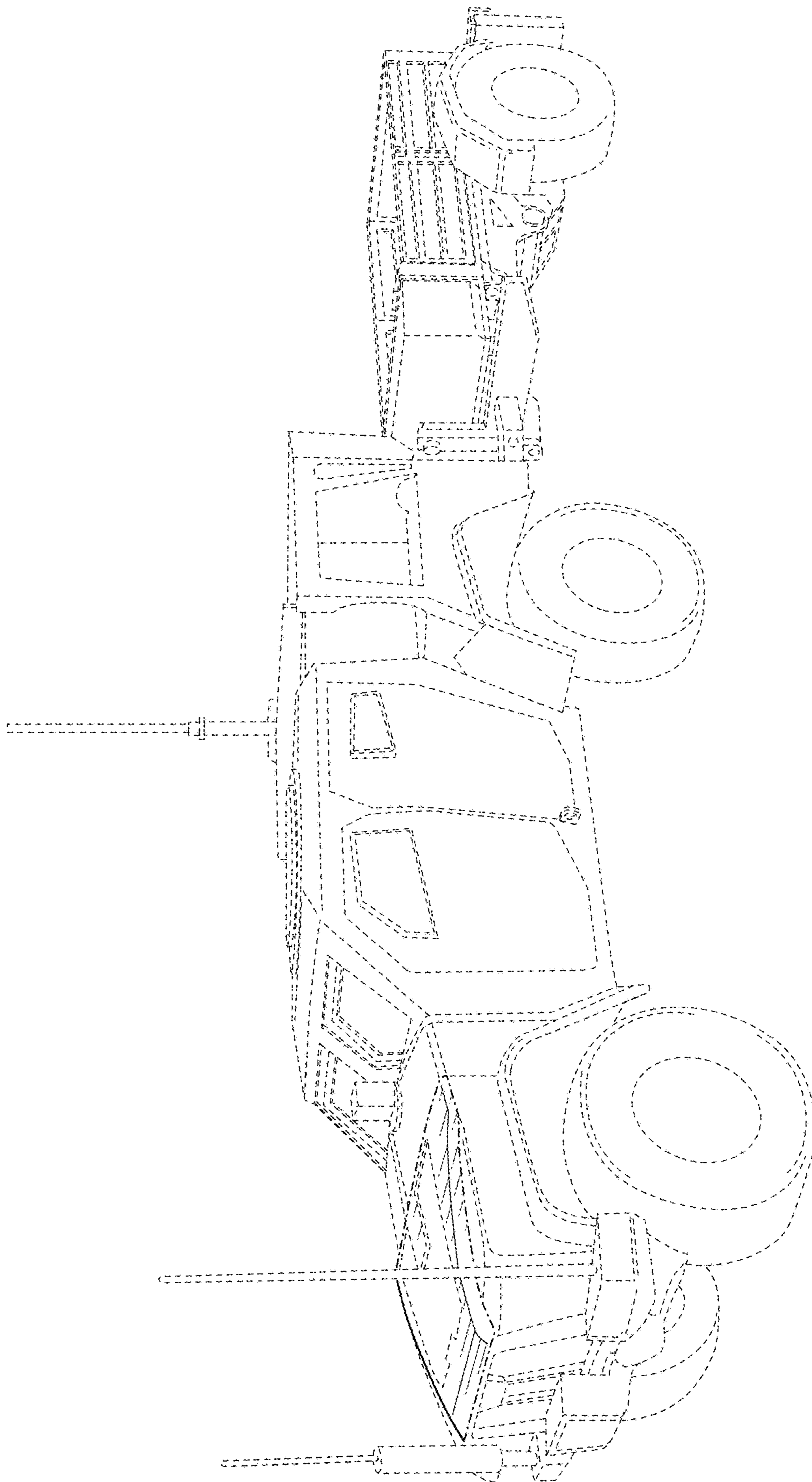

FIG. 9