



US00D909918S

(12) **United States Design Patent**
Langhals et al.

(10) **Patent No.:** **US D909,918 S**

(45) **Date of Patent:** **** Feb. 9, 2021**

(54) **AUTOMOBILE BODY**

(71) Applicants: **Taylor A. Langhals**, Waterford, MI (US); **Brian H. Nielander**, Royal Oak, MI (US); **Mark T. Allen**, Oxford, MI (US)

(72) Inventors: **Taylor A. Langhals**, Waterford, MI (US); **Brian H. Nielander**, Royal Oak, MI (US); **Mark T. Allen**, Oxford, MI (US)

(73) Assignee: **FCA US LLC**, Auburn Hills, MI (US)

(**) Term: **15 Years**

(21) Appl. No.: **29/735,142**

(22) Filed: **May 19, 2020**

Related U.S. Application Data

(62) Division of application No. 29/670,328, filed on Nov. 15, 2018, now Pat. No. Des. 887,899.

(51) **LOC (13) Cl.** **12-08**

(52) **U.S. Cl.**
USPC **D12/98**; D12/91

(58) **Field of Classification Search**
USPC D12/86, 90-92, 98; D21/424, 433, 434;
296/181.1-181.5, 183.1
CPC B62D 25/00; B62D 25/06; B62D 33/00;
B62D 35/00
See application file for complete search history.

(56) **References Cited**

U.S. PATENT DOCUMENTS

D624,851 S * 10/2010 Feng D12/91
D801,860 S * 11/2017 Piscitelli D12/91

D810,626 S * 2/2018 Macey D12/91
D811,270 S * 2/2018 Zhang D12/91
D825,385 S * 8/2018 Ma D12/91
D827,495 S * 9/2018 Piscitelli D12/91
D827,496 S * 9/2018 Badstuebner D12/91
D828,223 S * 9/2018 Piscitelli D12/91
D840,270 S * 2/2019 Goodrich D12/91
D860,864 S * 9/2019 Goodrich D12/91
D860,865 S * 9/2019 Goodrich D12/91
D860,866 S * 9/2019 Goodrich D12/91
D860,867 S * 9/2019 Goodrich D12/91
D887,899 S * 6/2020 Langhals D12/91

* cited by examiner

Primary Examiner — Melody N Brown

(74) *Attorney, Agent, or Firm* — Ralph E. Smith

(57) **CLAIM**

The ornamental design for an automobile body, as shown and described.

DESCRIPTION

FIG. 1 is a front perspective view of an automobile body showing our new design;
FIG. 2 is a rear perspective view thereof;
FIG. 3 is a top plan view thereof;
FIG. 4 is a side view thereof;
FIG. 5 is an opposite side view thereof;
FIG. 6 is a front elevational view thereof; and,
FIG. 7 is a rear elevational view thereof.
It will be understood that the broken lines shown in the drawings illustrate portions of the automobile body that form no part of claimed design.

1 Claim, 6 Drawing Sheets

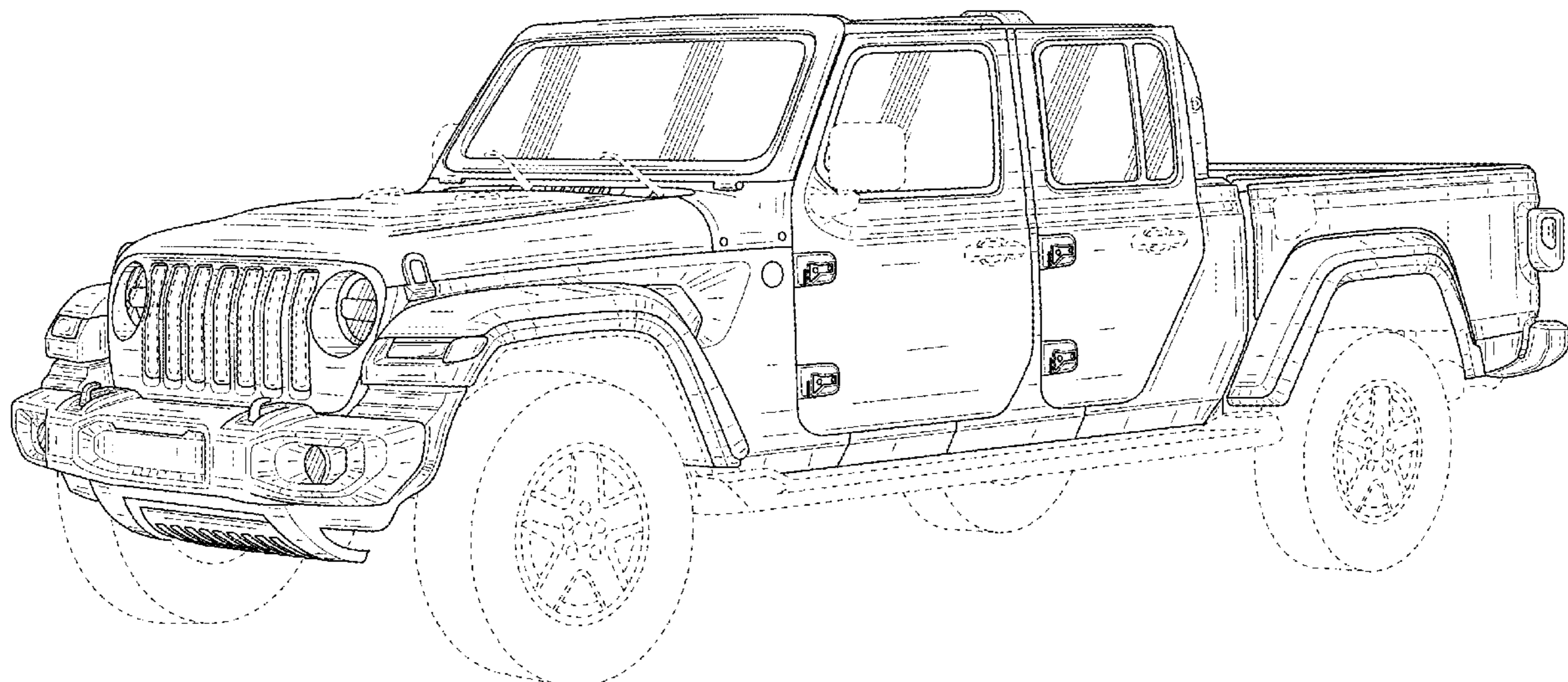

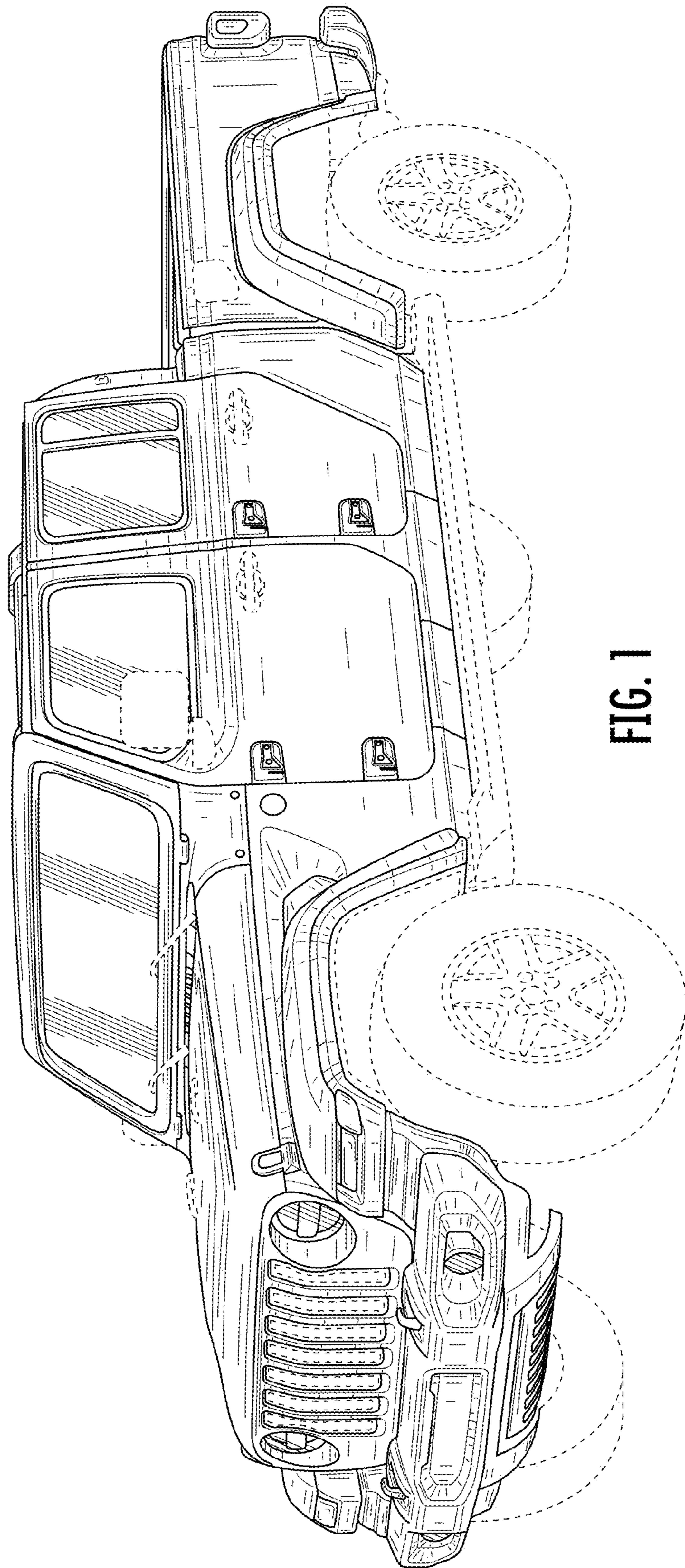

FIG. 1

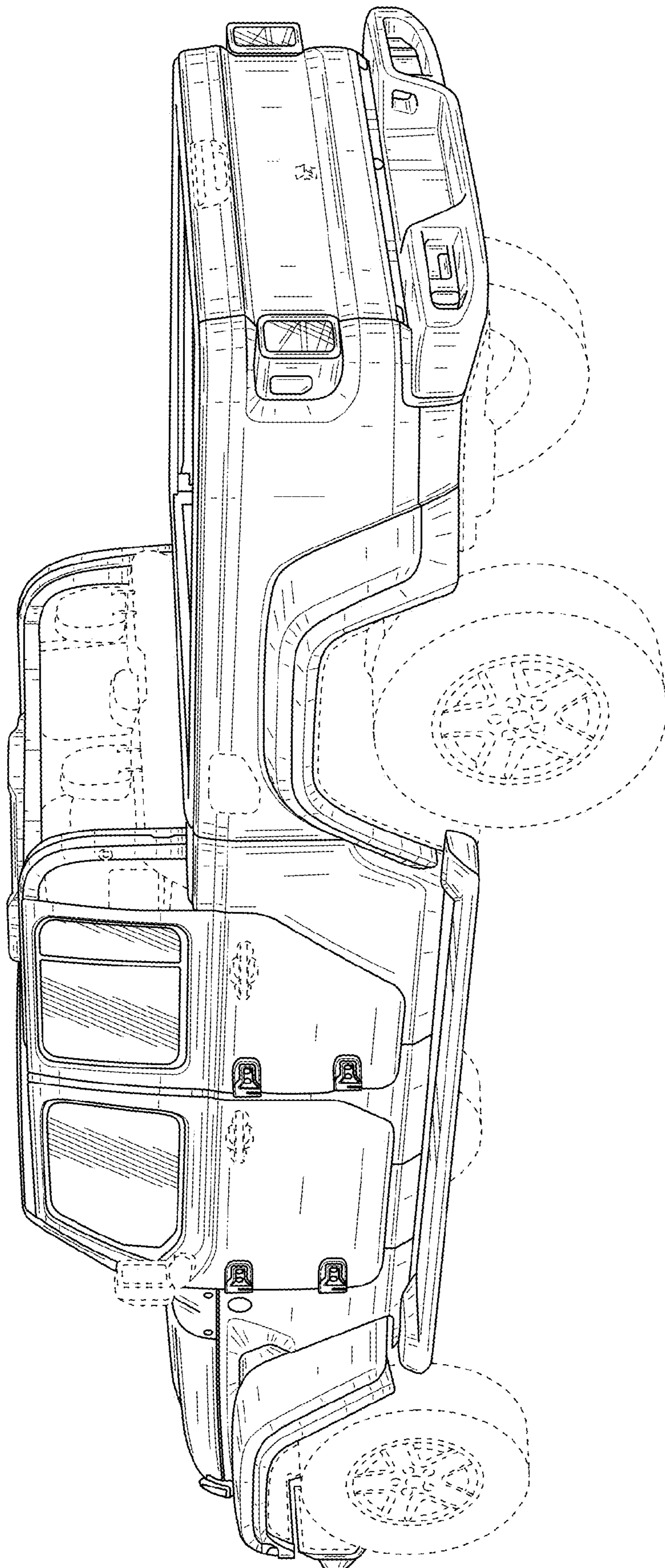

FIG. 2

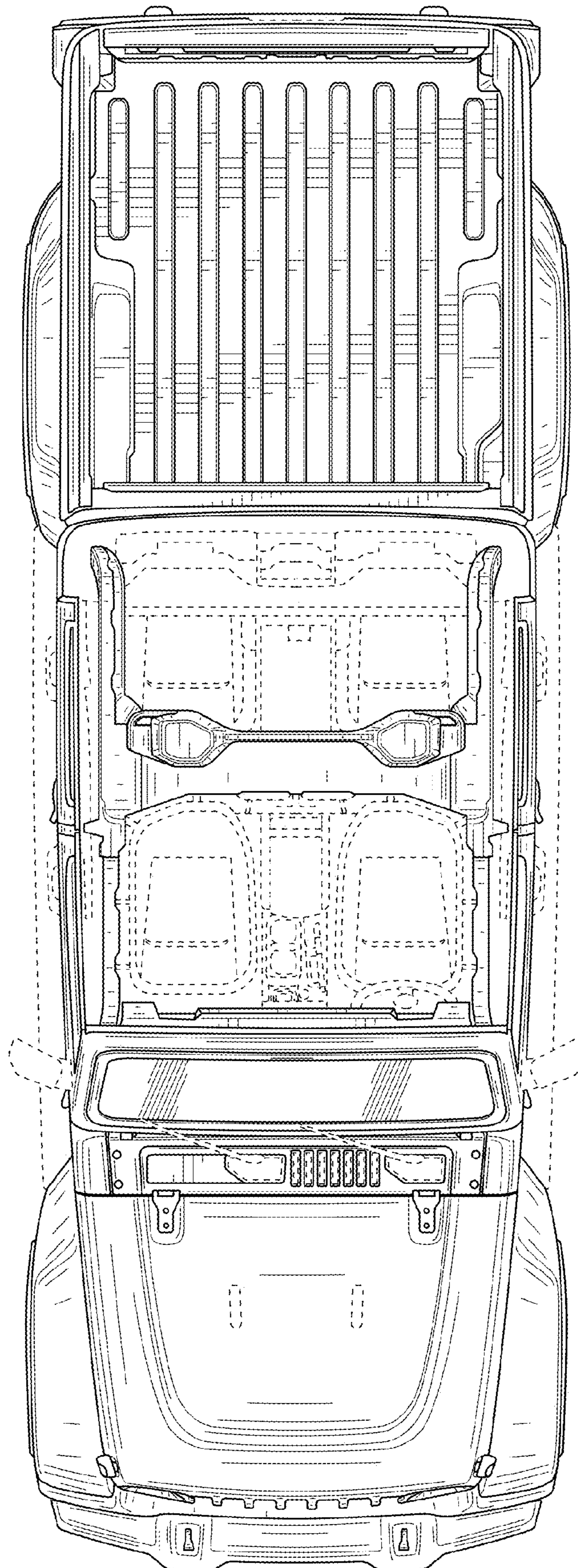

FIG. 3

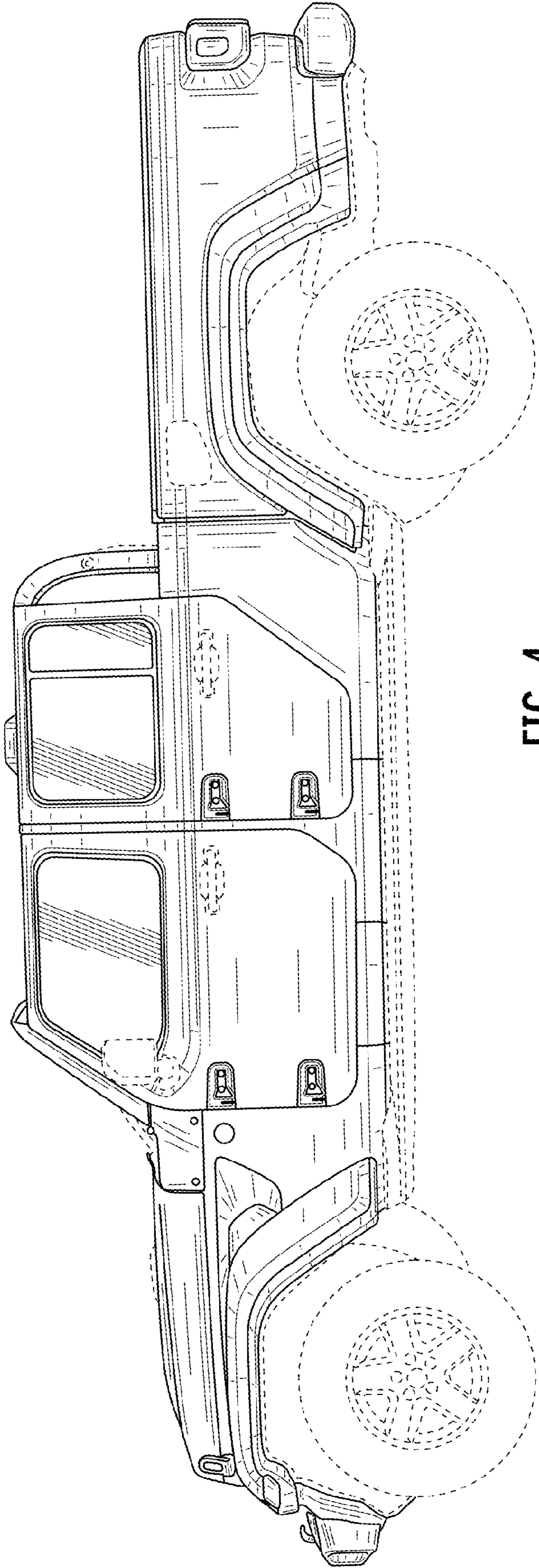

FIG. 4

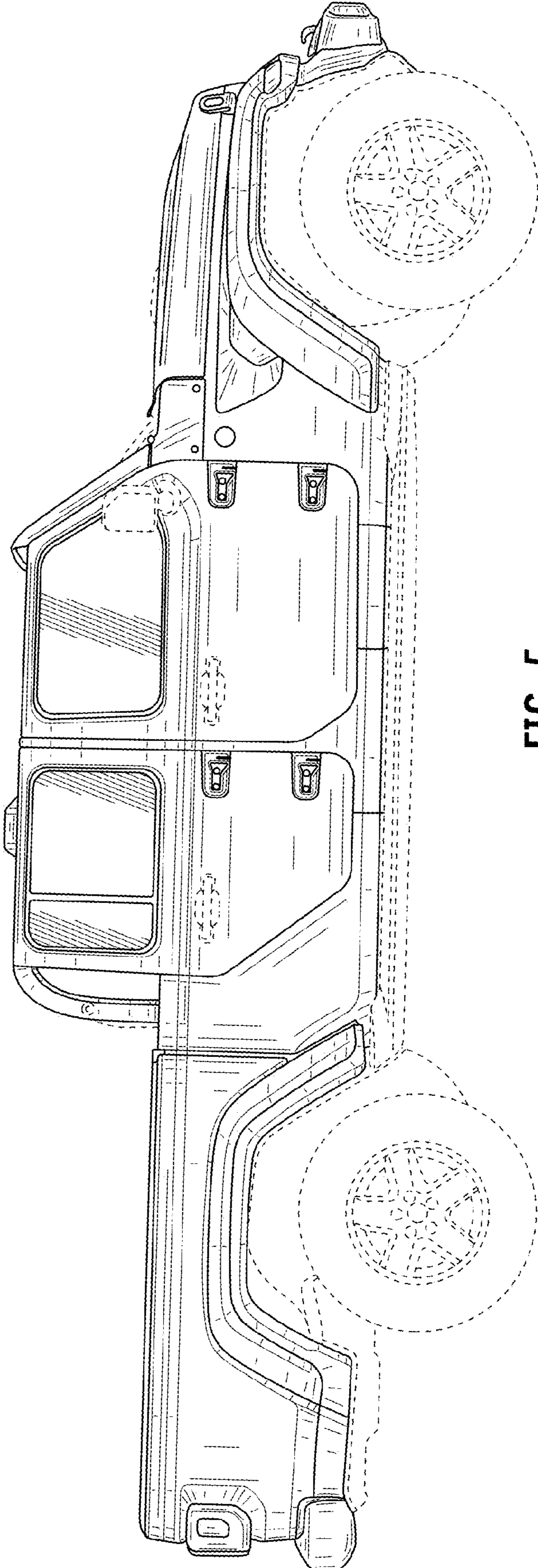

FIG. 5

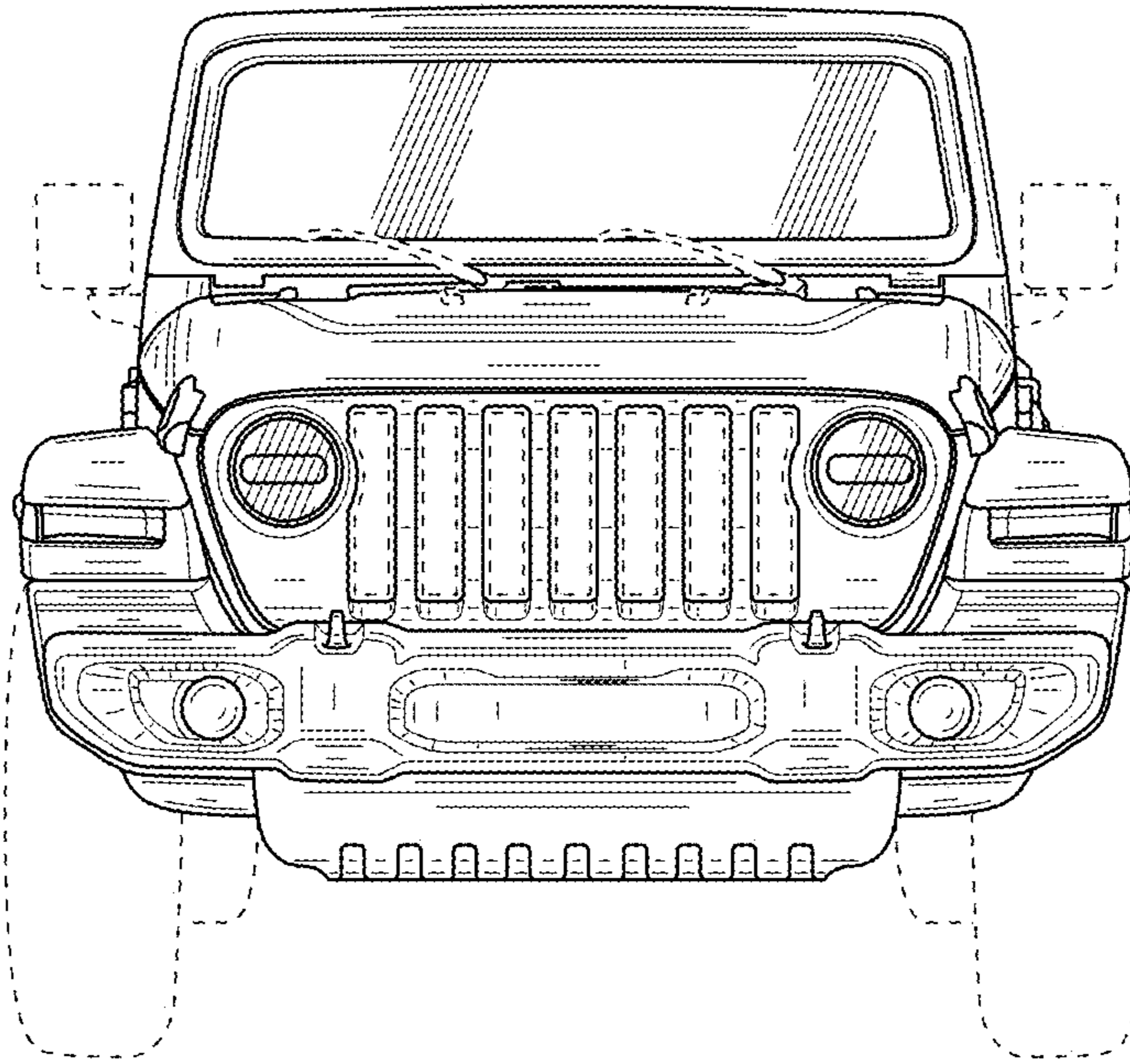

FIG. 6

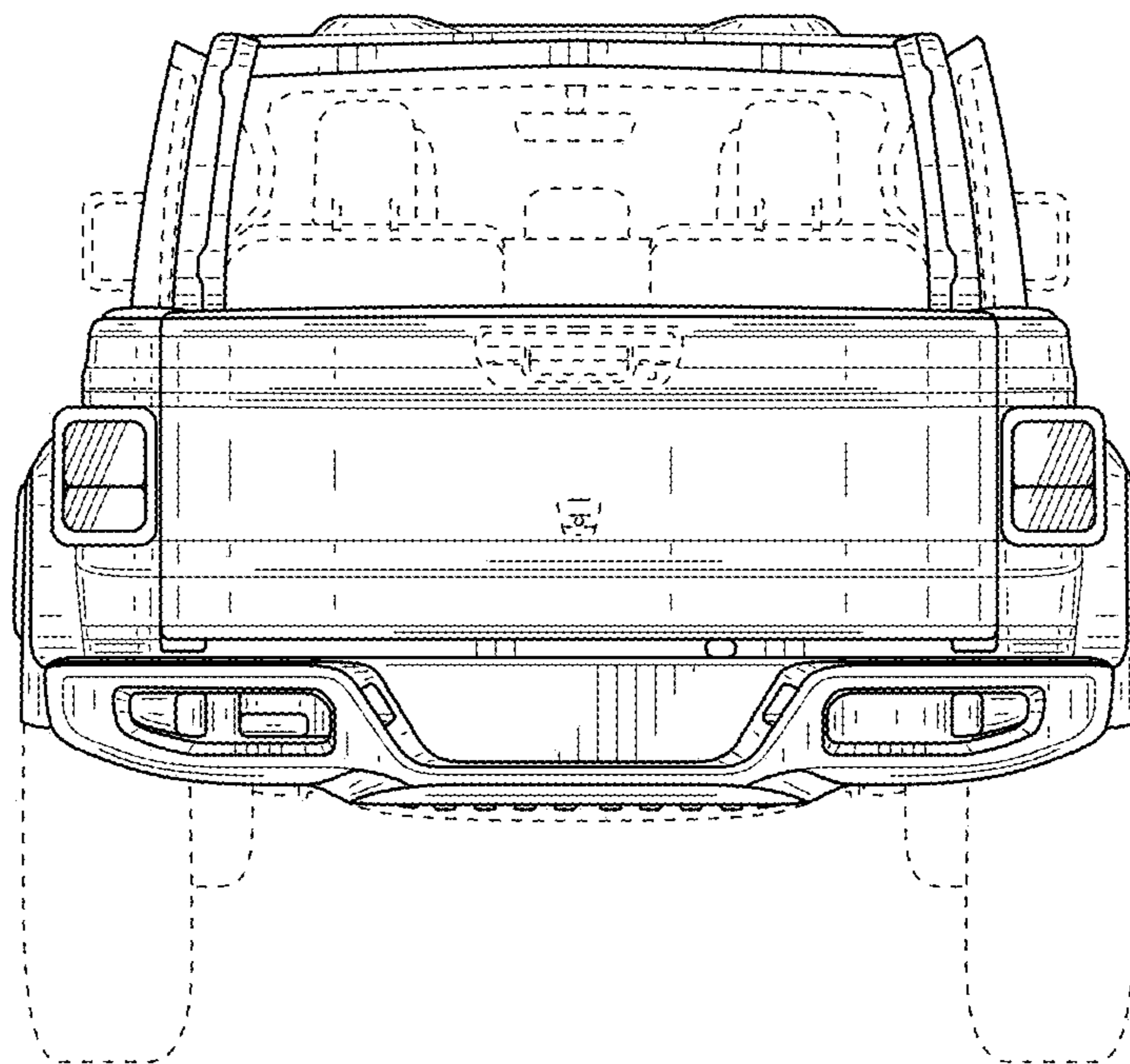

FIG. 7