



US00D909639S

(12) **United States Design Patent**
Chen

(10) **Patent No.:** **US D909,639 S**

(45) **Date of Patent:** **** Feb. 2, 2021**

(54) **CAR HEADLIGHT**

(71) Applicant: **ZHEJIANG YUANZHENG AUTO & MOTORCYCLE ACCESSORIES CO., LTD.**, Ruian (CN)

(72) Inventor: **Yu Chen**, Ruian (CN)

(**) Term: **15 Years**

(21) Appl. No.: **29/726,349**

(22) Filed: **Mar. 3, 2020**

(51) **LOC (13) Cl.** **26-06**

(52) **U.S. Cl.**
USPC **D26/28**

(58) **Field of Classification Search**
USPC D26/28-36, 139
CPC F21S 48/00; F21S 48/10; F21S 48/115;
F21S 48/225; F21S 48/1233; F21S
48/1266; F21S 48/1388; F21S 48/2268;
F21V 21/04; F21V 29/004; F21W
2103/35; F21W 3/40; F21W 2102/17;
F21W 2102/30; F21W 2103/00; F21W
2103/55; F21W 2104/00; F21W 2107/13;
F21W 2107/17; B60Q 9/13; B60Q 9/135;
B60Q 9/1375

See application file for complete search history.

(56) **References Cited**

U.S. PATENT DOCUMENTS

D593,233 S *	5/2009	Bai	D26/28
D597,689 S	8/2009	Sun		
D674,938 S *	1/2013	Lai	D26/28
D743,065 S *	11/2015	Weil	D26/28
D787,721 S *	5/2017	Lai	D26/28
D797,332 S *	9/2017	Lin	D26/28
D809,682 S *	2/2018	Lin	D26/28

D822,241 S * 7/2018 Lee D26/28
D824,058 S * 7/2018 Hong D26/28

* cited by examiner

Primary Examiner — Marcus A Jackson

(74) *Attorney, Agent, or Firm* — ZANIP

(57) **CLAIM**

The ornamental design for a car headlight, as shown and described.

DESCRIPTION

FIG. 1 is a front and top perspective view of a first embodiment of a car headlight, showing my new design; FIG. 2 is a front and bottom perspective view thereof; FIG. 3 is a front elevational view thereof; FIG. 4 is a back elevational view thereof; FIG. 5 is a left side elevational view thereof; FIG. 6 is a right side elevational view thereof; FIG. 7 is a top plan view thereof; FIG. 8 is a bottom plan view thereof; FIG. 9 is an enlarged view of a portion indicated in FIG. 1; FIG. 10 is a front and top perspective view of a second embodiment of the car headlight; FIG. 11 is a front and bottom perspective view thereof; FIG. 12 is a front elevational view thereof; FIG. 13 is a back elevational view thereof; FIG. 14 is a left side elevational view thereof; FIG. 15 is a right side elevational view thereof; FIG. 16 is a top plan view thereof; FIG. 17 is a bottom plan view thereof; and, FIG. 18 is an enlarged view of a portion indicated in FIG. 10. The broken lines in the figures illustrate portions of the car headlight that form no part of the claimed design. The dash dot dash lines in FIGS. 1, 9, 10 and 18 are for the purpose of depicting the cut line of the enlarged view and form no part of the claim.

1 Claim, 18 Drawing Sheets

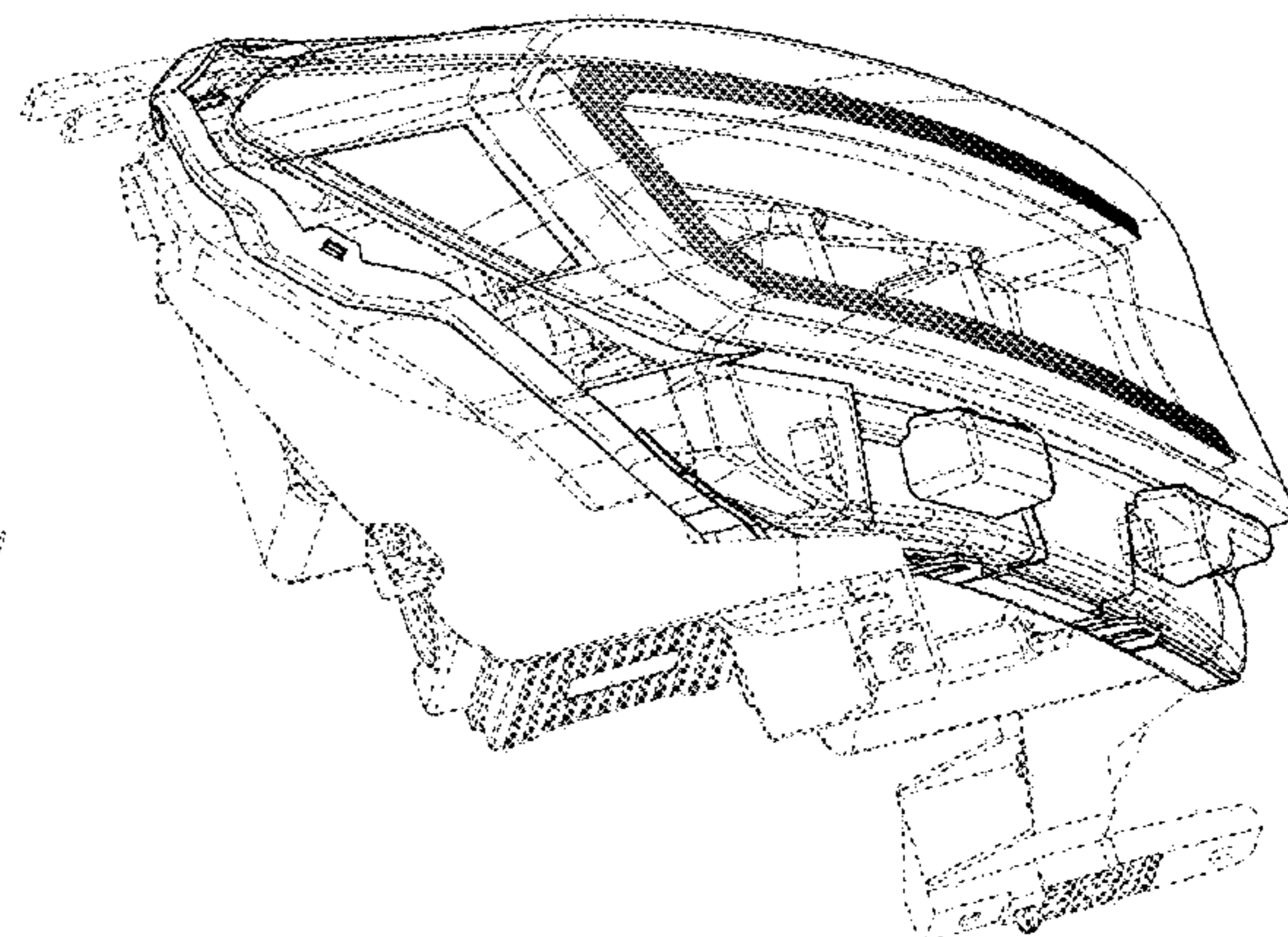
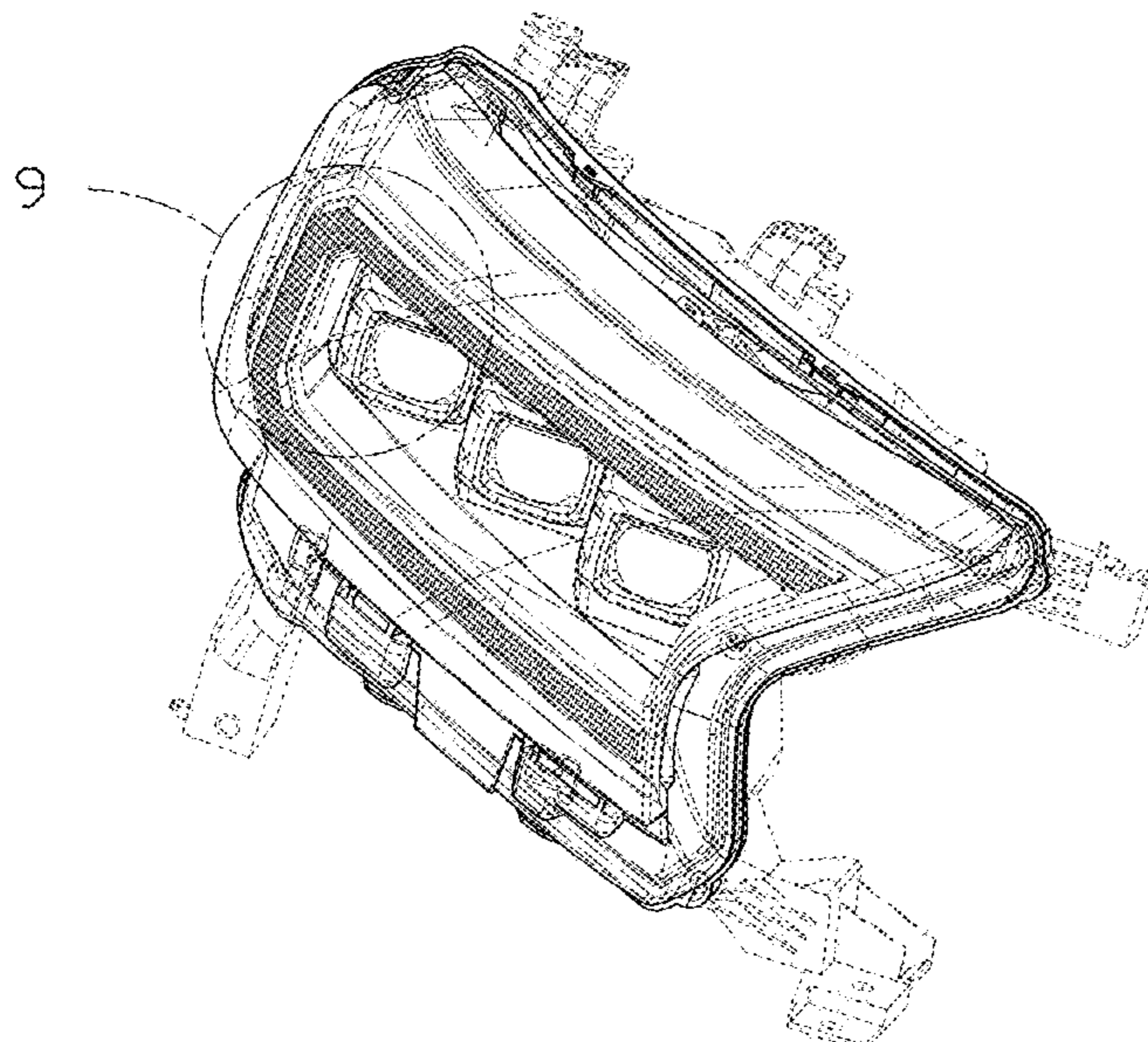

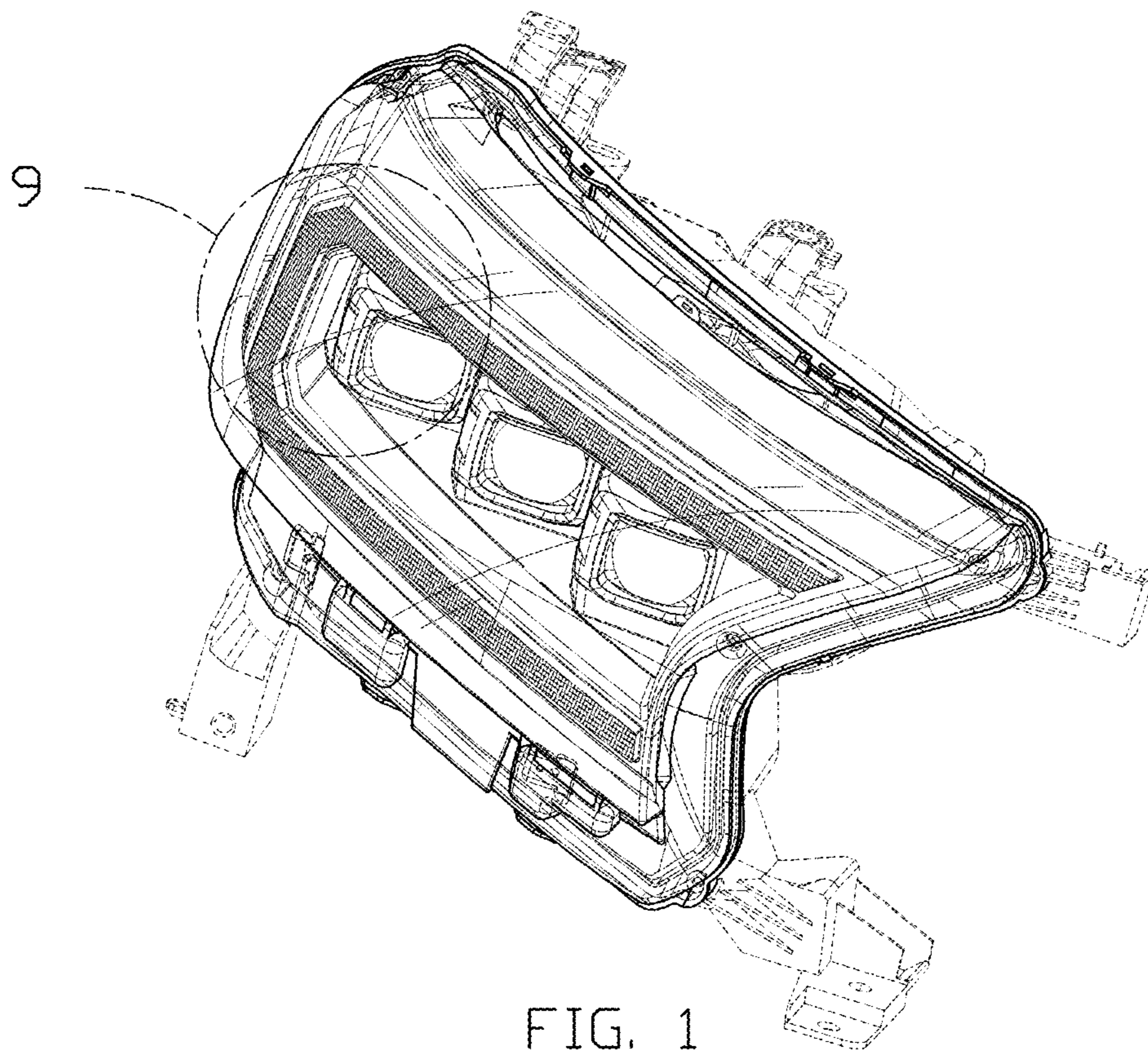

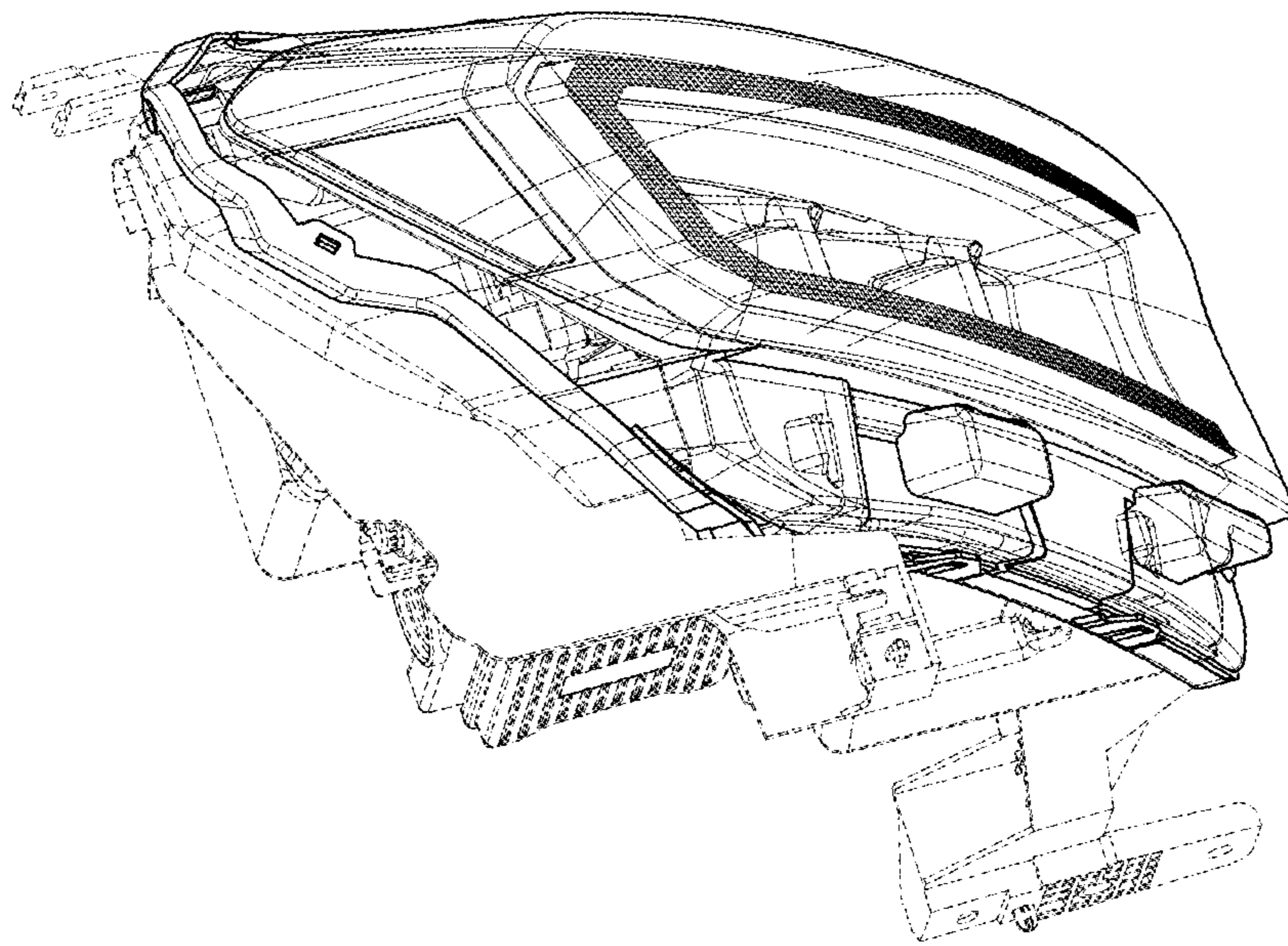

FIG. 2

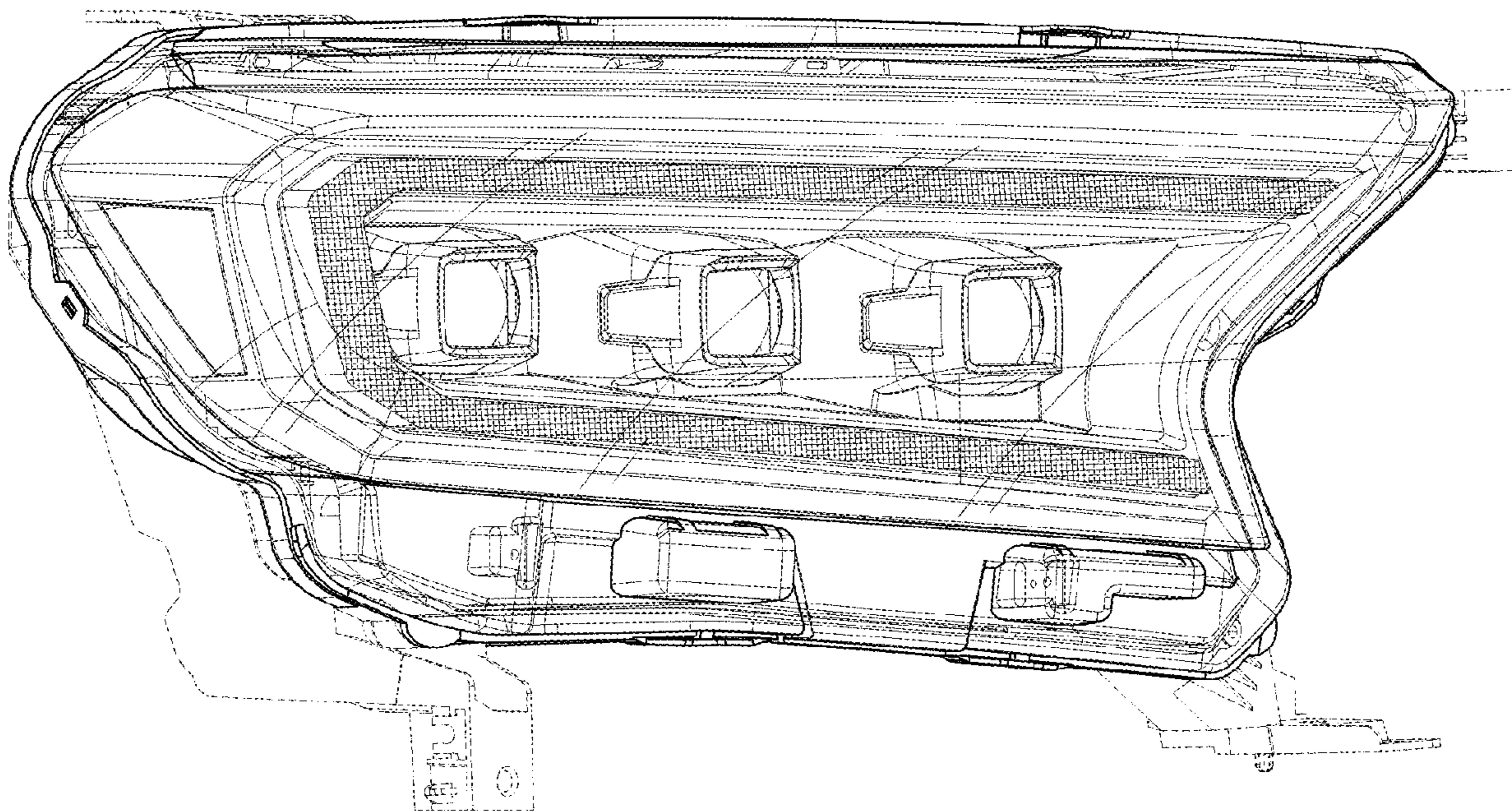

FIG. 3

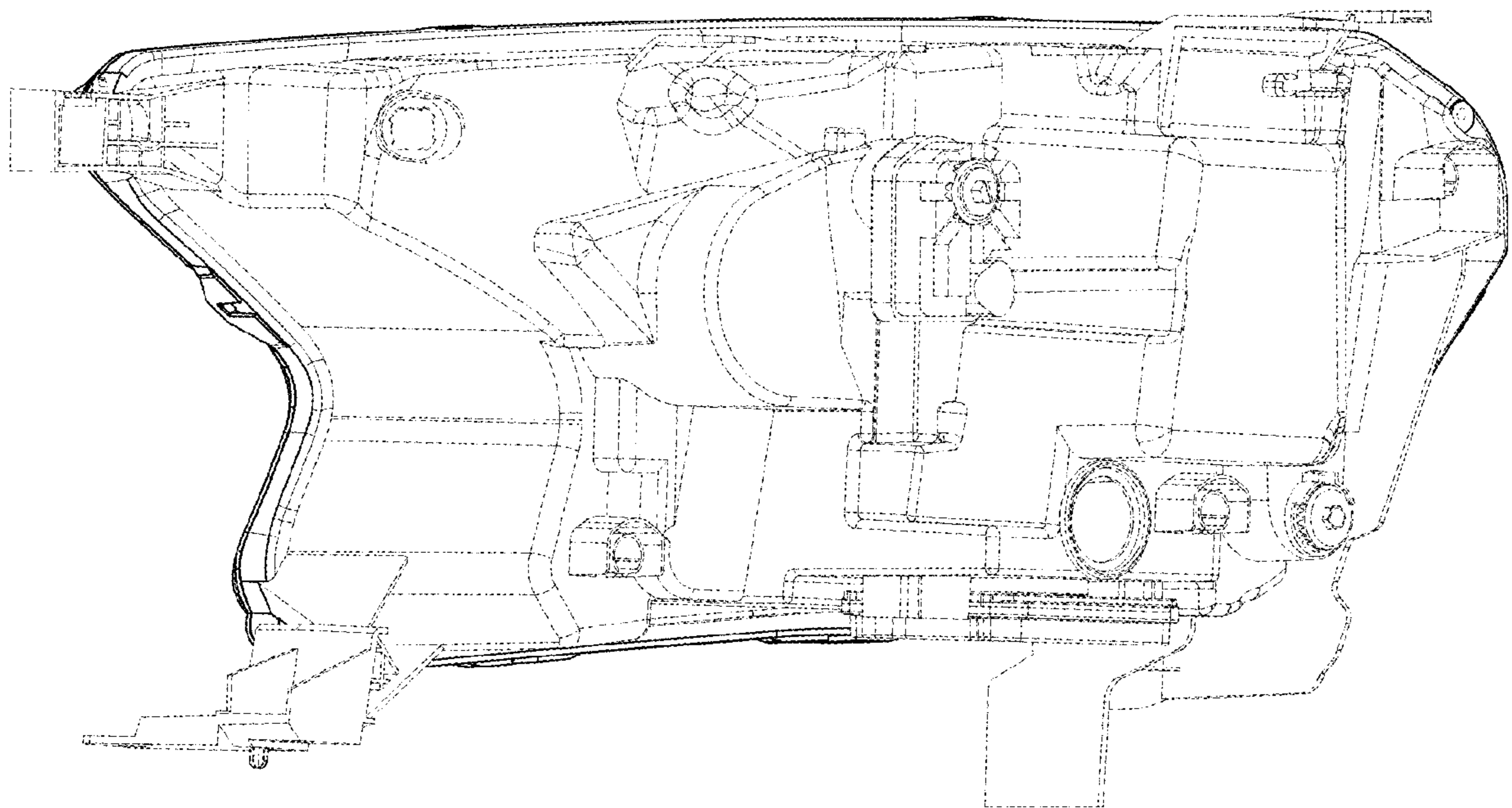

FIG. 4

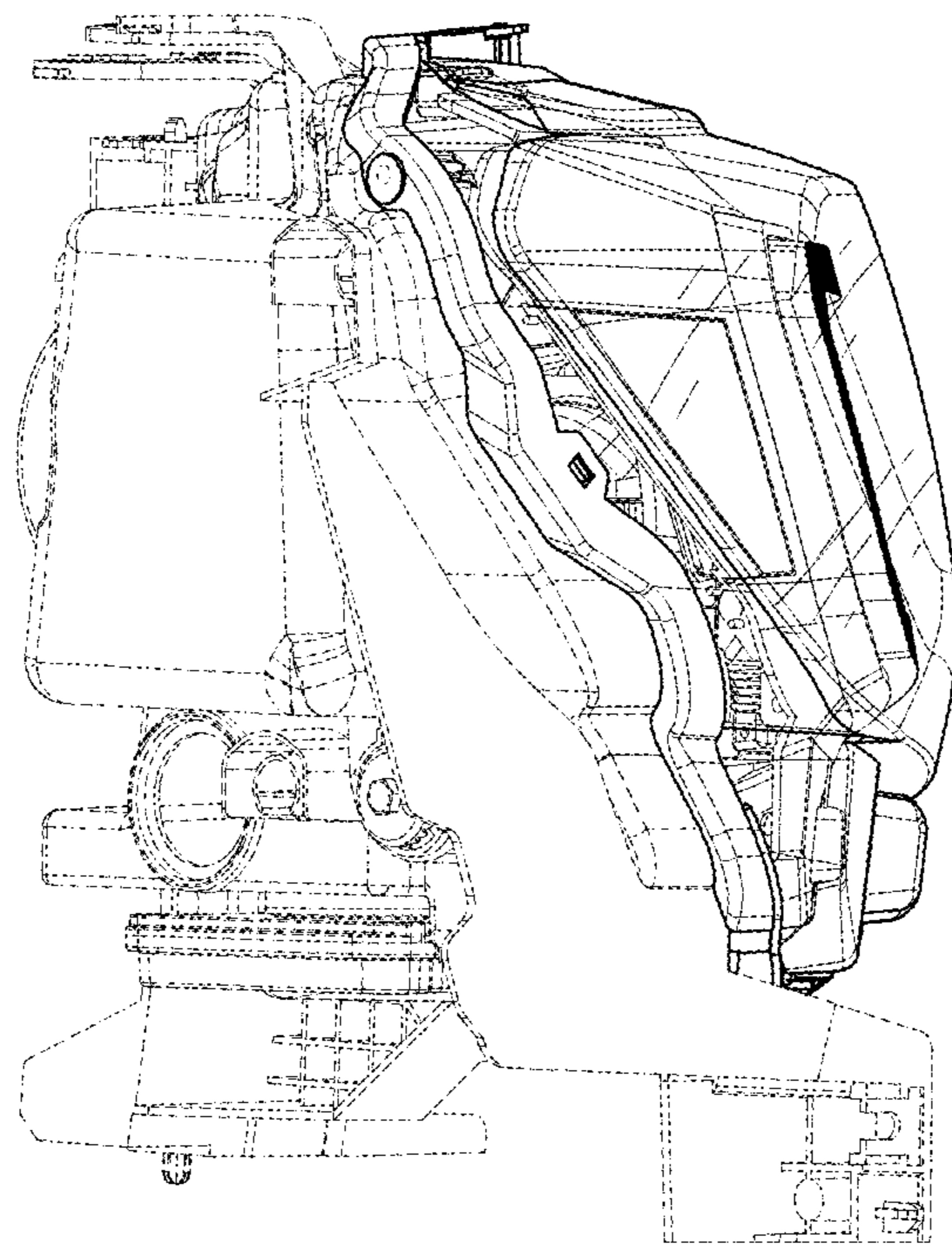

FIG. 5

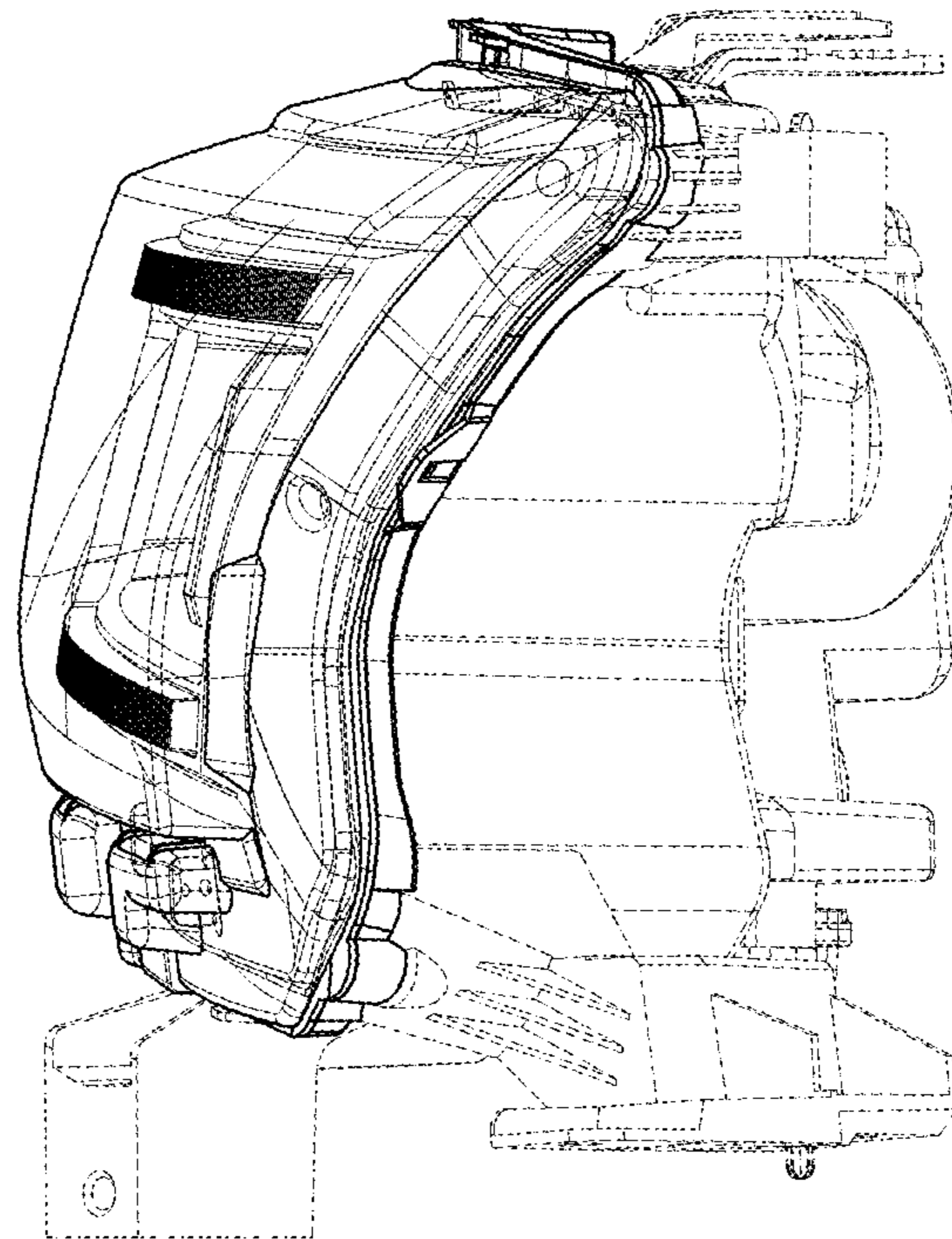

FIG. 6

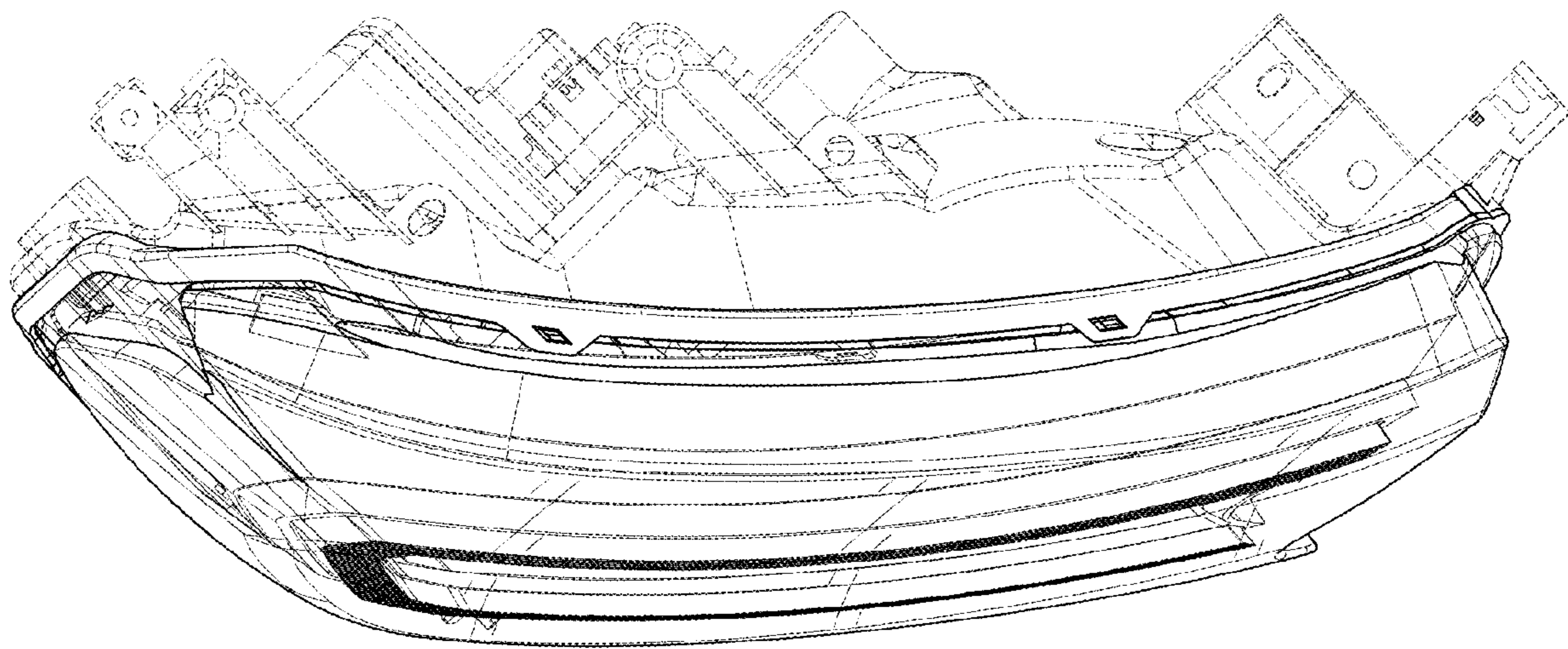

FIG. 7

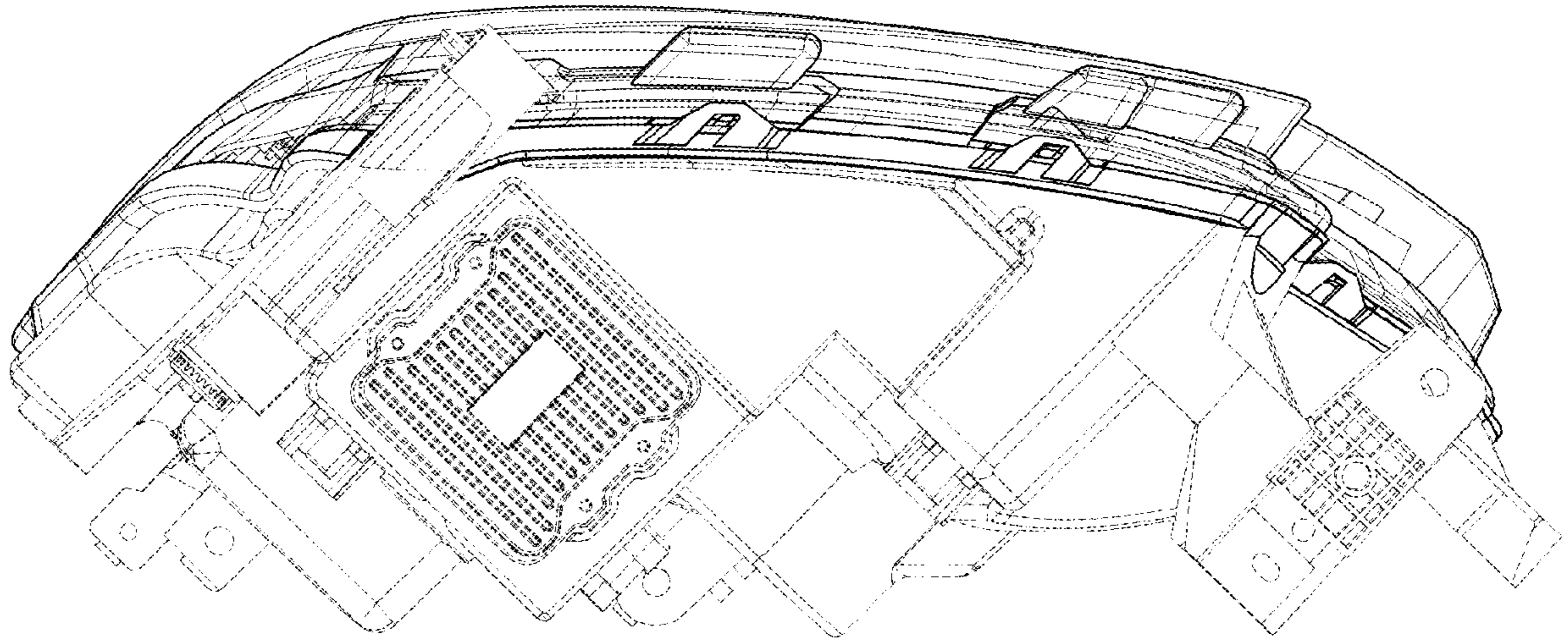

FIG. 8

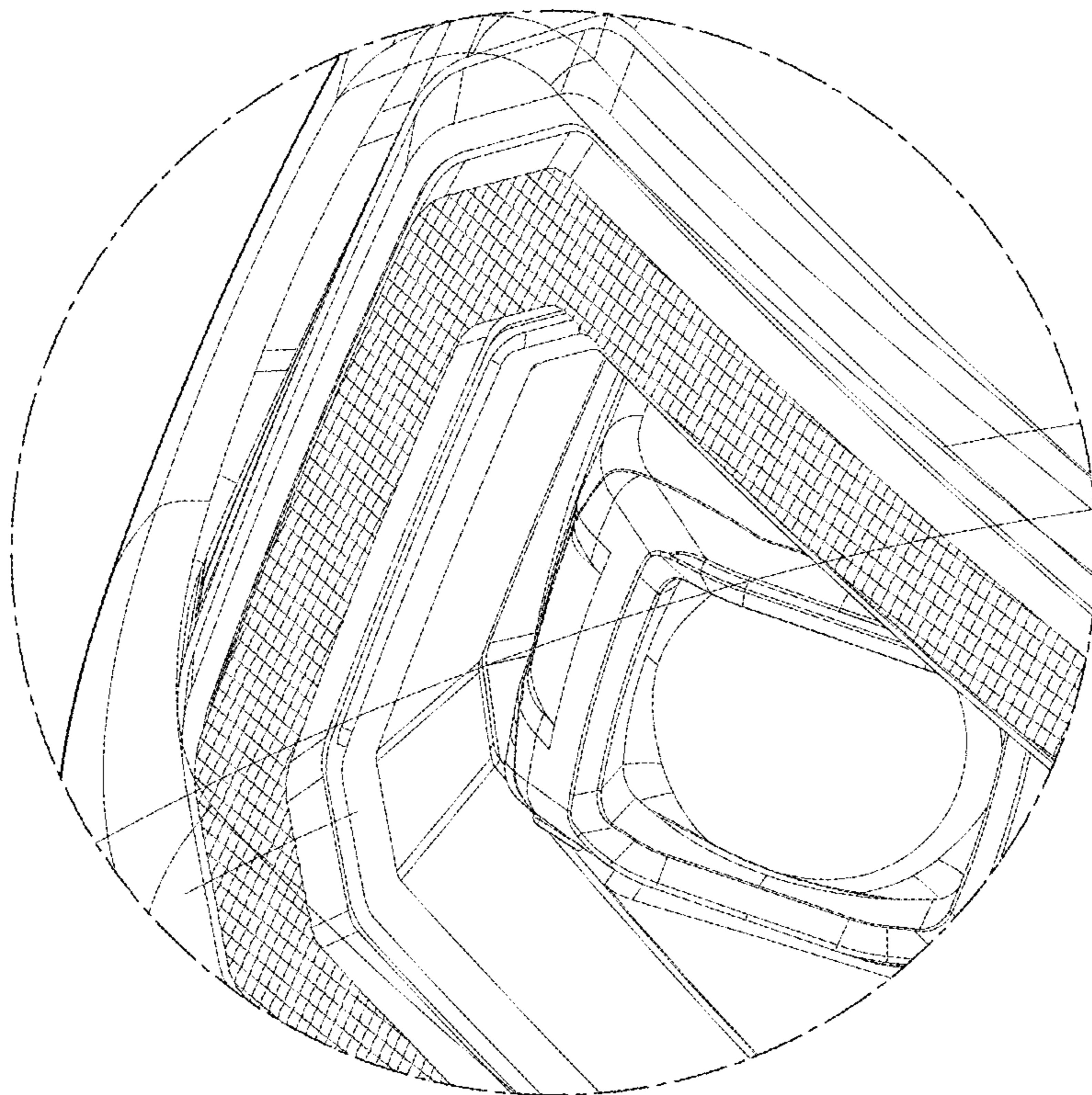
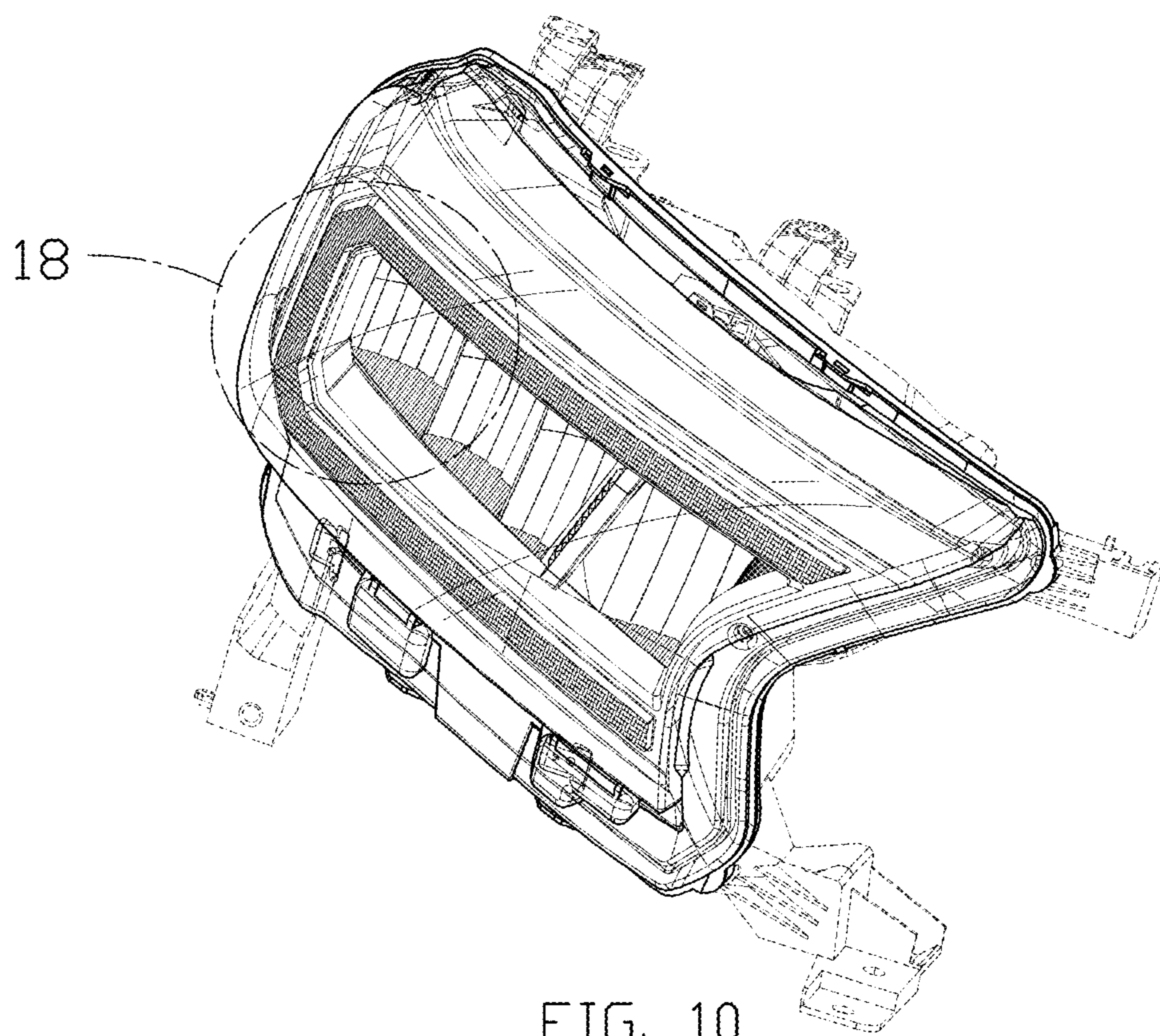

FIG. 9



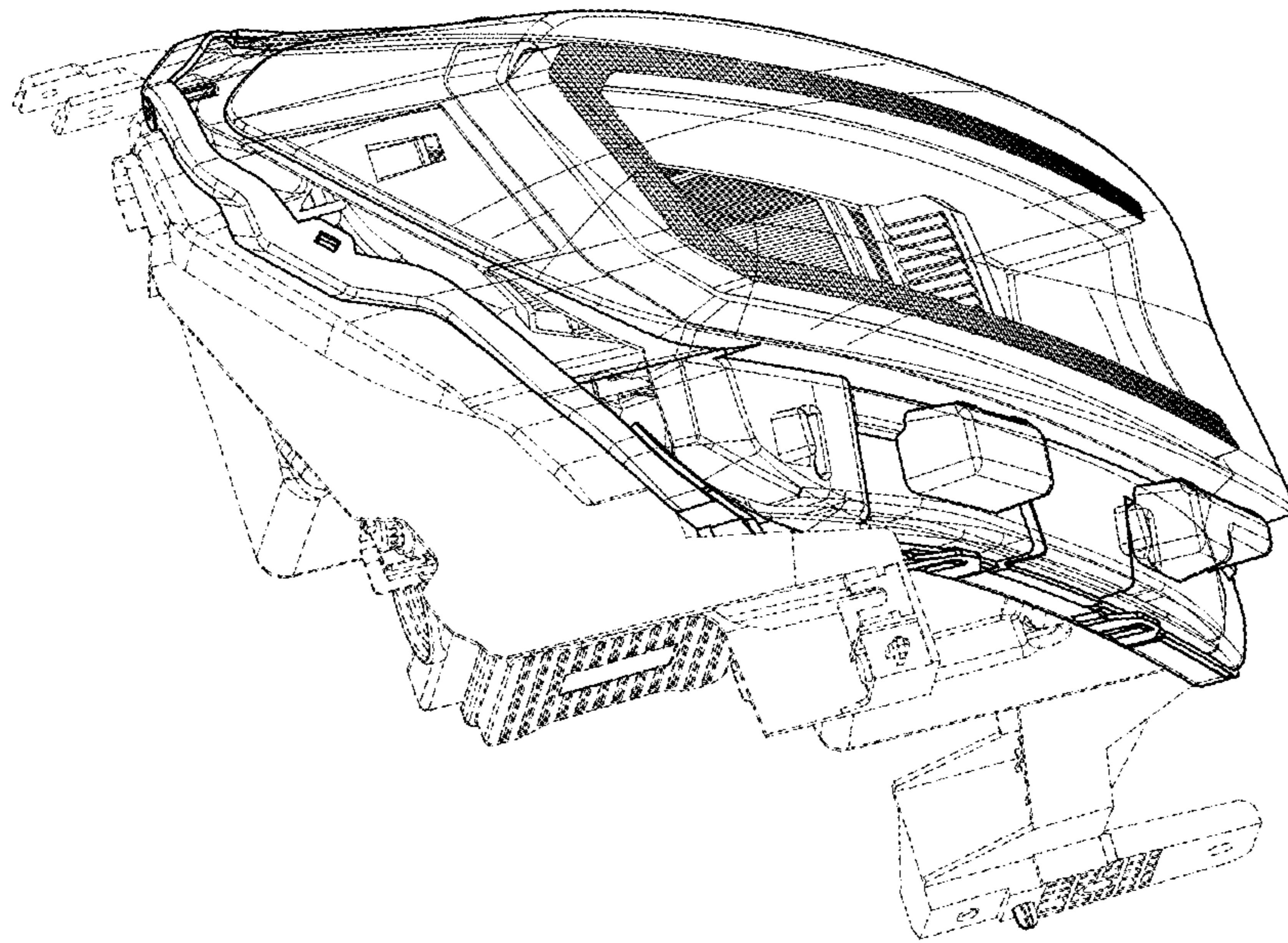

FIG. 11

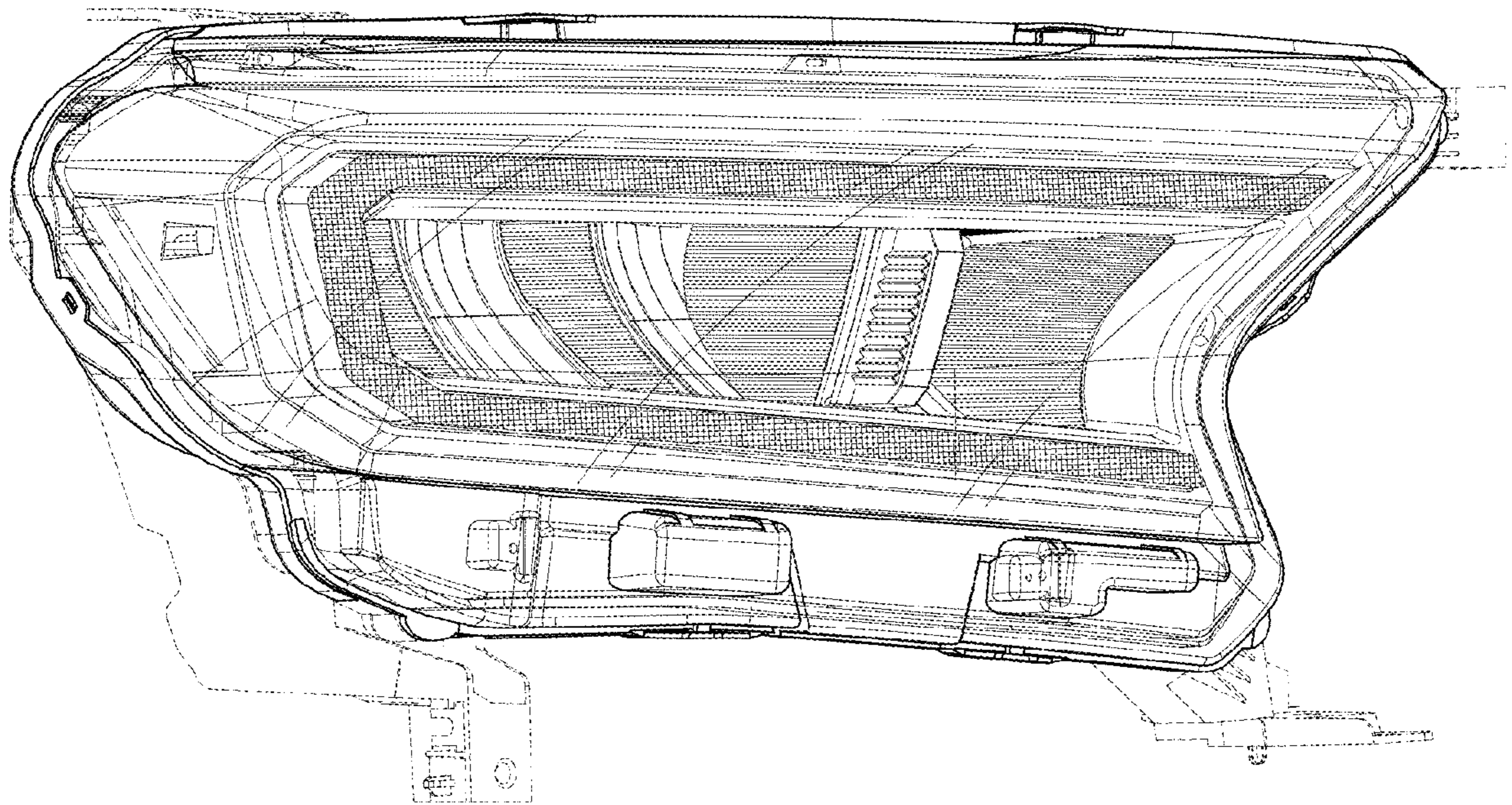

FIG. 12

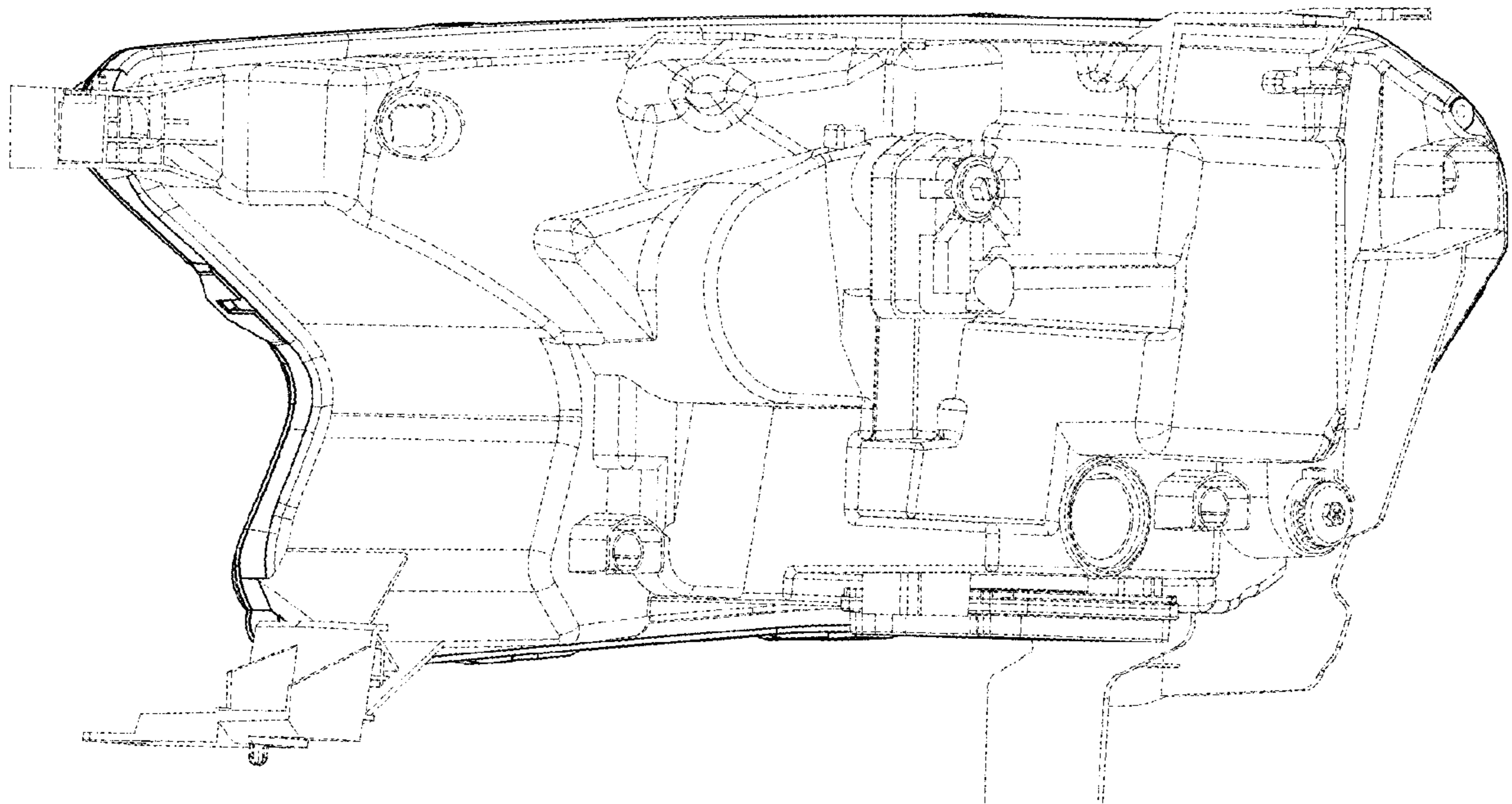

FIG. 13

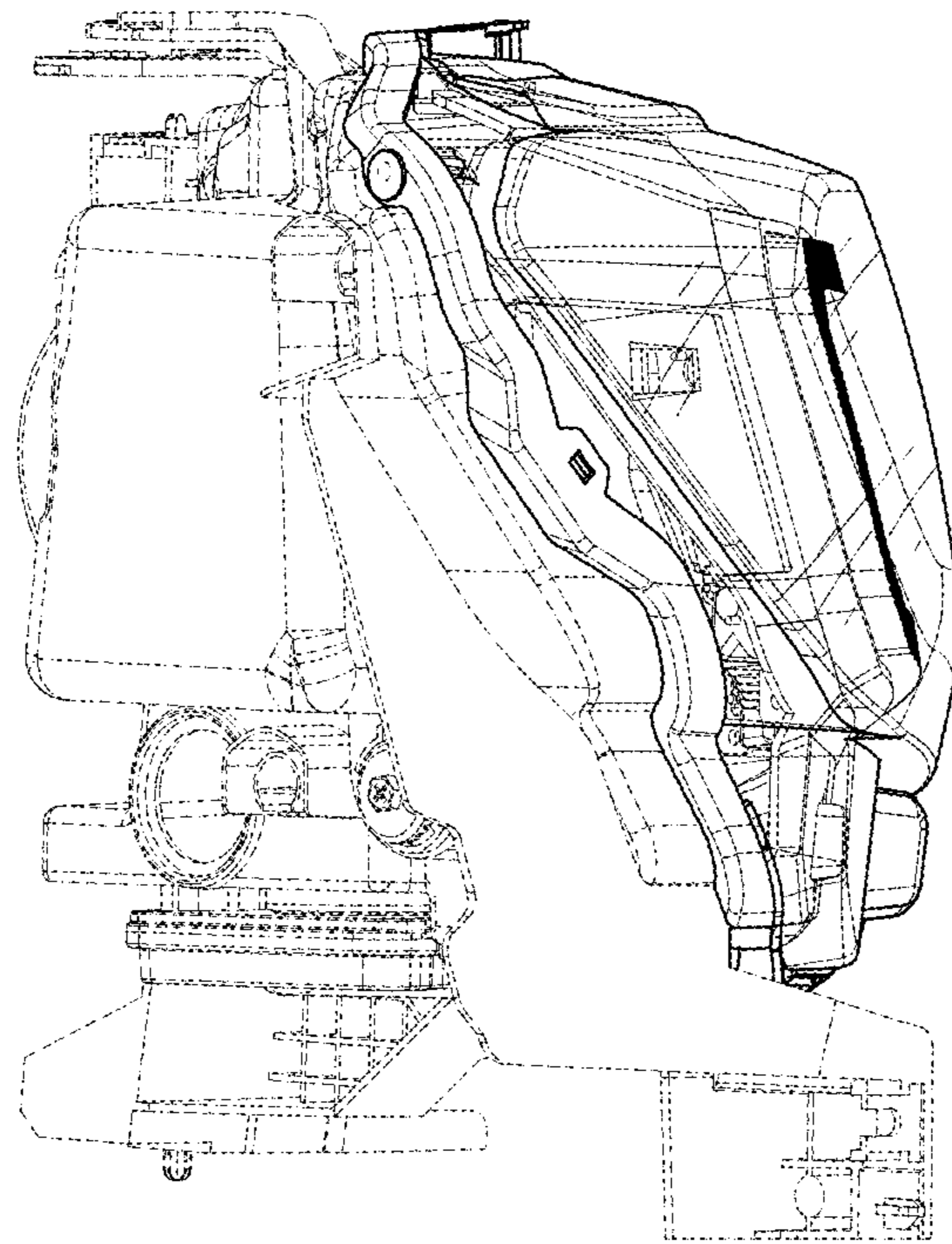

FIG. 14

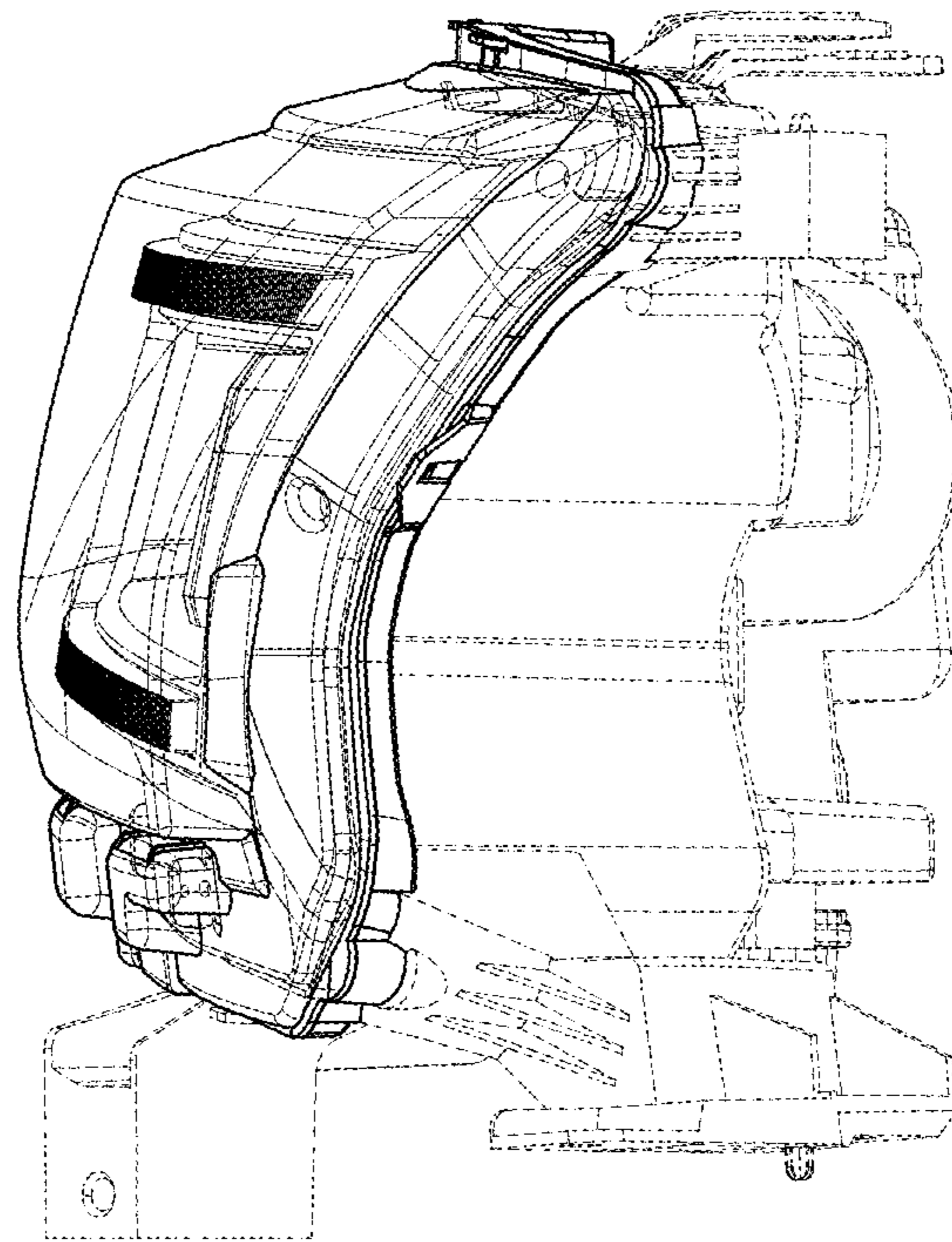

FIG. 15

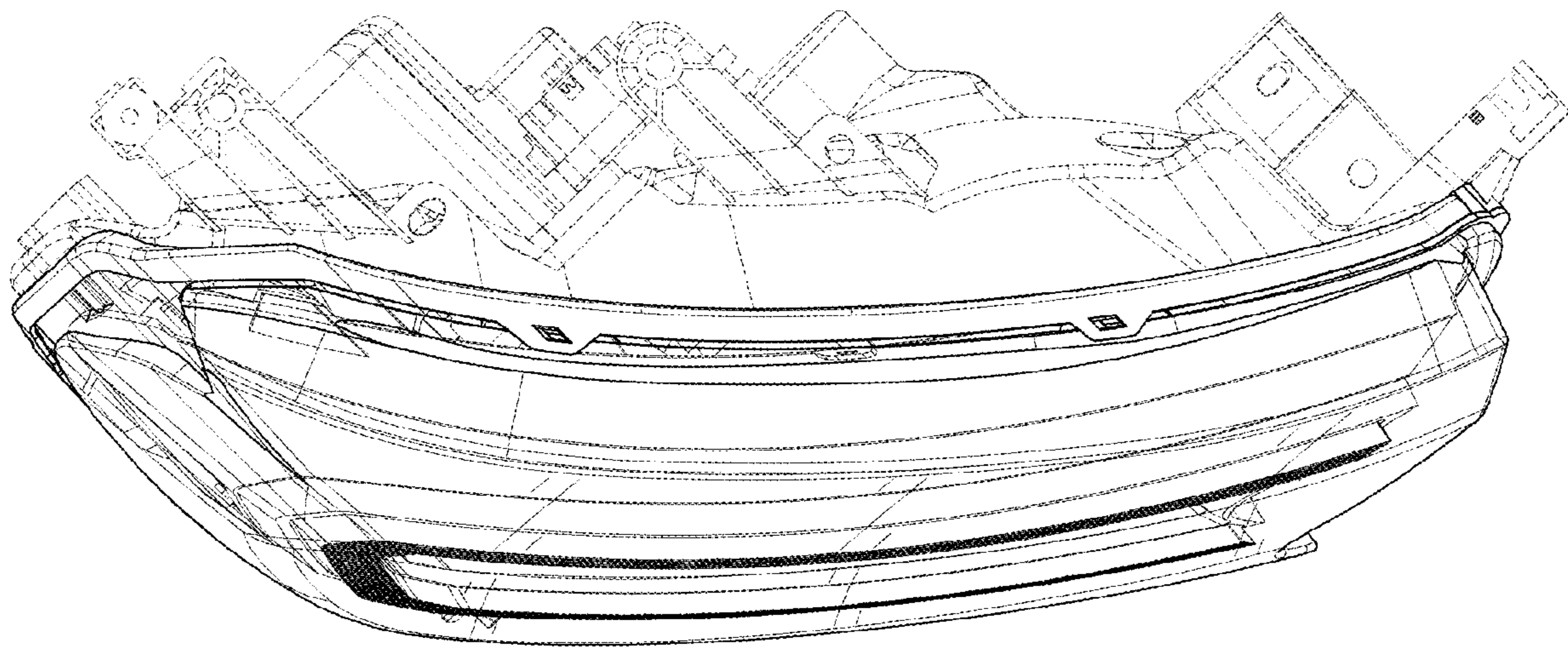

FIG. 16

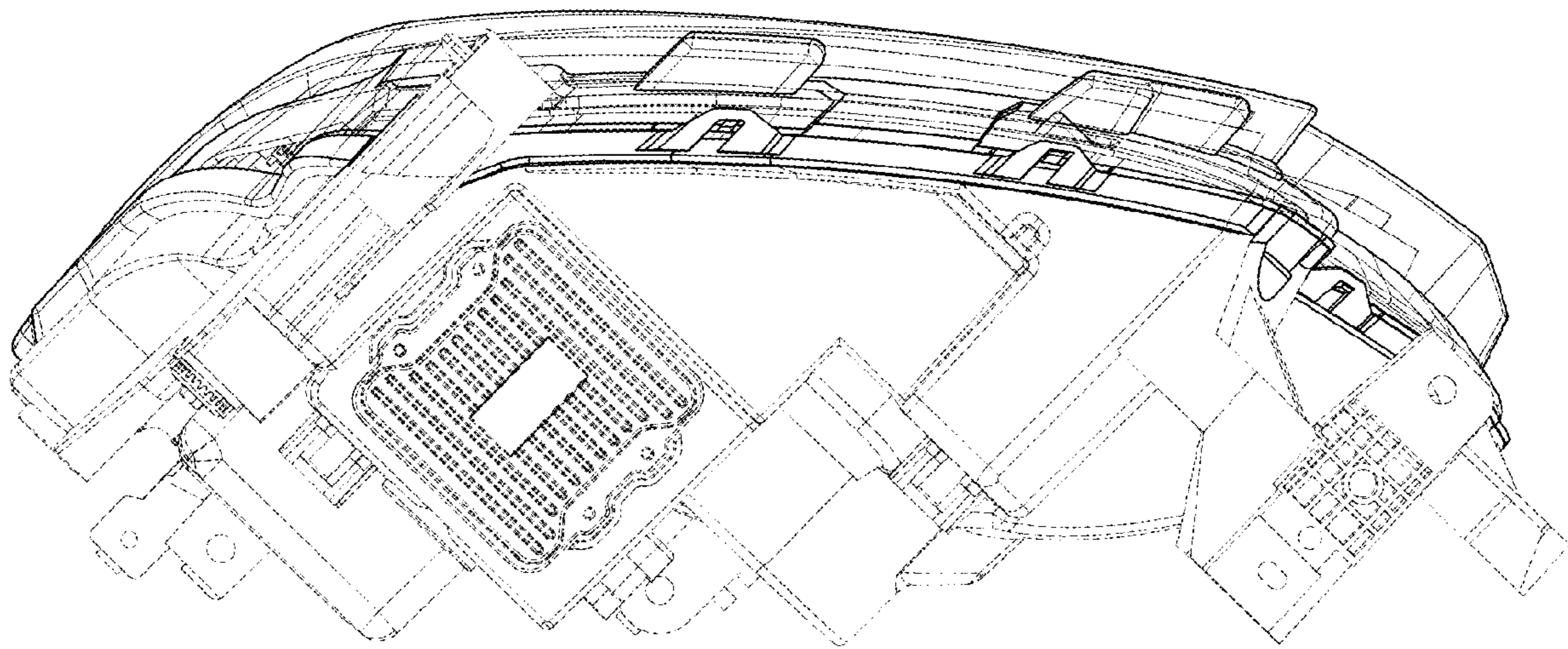

FIG. 17

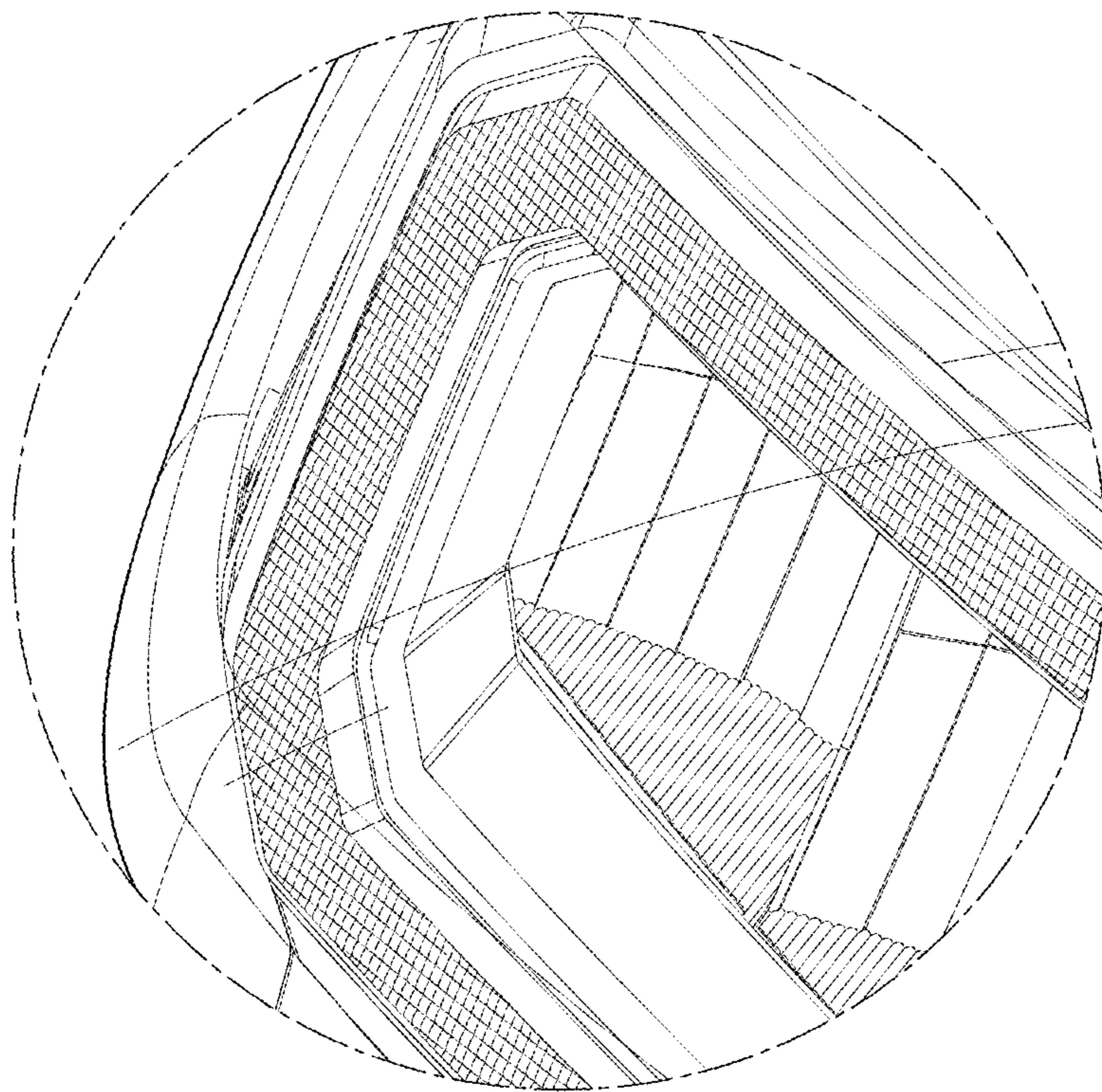

FIG. 18