



US00D909419S

(12) **United States Design Patent**  
**Nemoto et al.**

(10) **Patent No.:** **US D909,419 S**  
(45) **Date of Patent:** **\*\* Feb. 2, 2021**

(54) **FLUID PRESSURE CYLINDER**

(71) Applicant: **SMC CORPORATION**, Tokyo (JP)  
(72) Inventors: **Shinichiro Nemoto**, Tsukubamirai (JP);  
**Yuu Mizutani**, Tsukubamirai (JP);  
**Masahiko Kawakami**, Tsukubamirai (JP);  
**Sho Aso**, Tsukubamirai (JP);  
**Shuichi Shibuya**, Tsukubamirai (JP)  
(73) Assignee: **SMC CORPORATION**, Tokyo (JP)

(\*\*) Term: **15 Years**

(21) Appl. No.: **29/706,492**

(22) Filed: **Sep. 20, 2019**

(30) **Foreign Application Priority Data**

Mar. 29, 2019 (CN) ..... 2019 3 0137122

(51) **LOC (13) Cl.** ..... **15-02**

(52) **U.S. Cl.**  
USPC ..... **D15/7**

(58) **Field of Classification Search**  
USPC ..... D15/7, 9, 143, 148, 149, 199; D10/85;  
D23/225, 233, 235

(Continued)

(56) **References Cited**

**U.S. PATENT DOCUMENTS**

D295,753 S \* 5/1988 LaBair ..... D15/7  
4,825,746 A \* 5/1989 Herner ..... F15B 15/082  
188/271

(Continued)

**FOREIGN PATENT DOCUMENTS**

CN 304695093 S 6/2018  
JP 846878-1 S 9/1992

(Continued)

**OTHER PUBLICATIONS**

SMC, Compact Air Cylinder—Standard Type, 2 in Bore, (first available Jul. 19, 2019), Amazon.com, URL:<<https://www.amazon.com/Compact-Air-Cylinder-Standard-Type/dp/B07VJX3FJS>> (Year: 2019).\*

com/Compact-Air-Cylinder-Standard-Type/dp/B07VJX3FJS> (Year: 2019).\*

(Continued)

*Primary Examiner* — Sheryl Lane  
*Assistant Examiner* — Mark T Philipps  
(74) *Attorney, Agent, or Firm* — Birch, Stewart, Kolasch & Birch, LLP

(57) **CLAIM**

The ornamental design for a fluid pressure cylinder, as shown and described.

**DESCRIPTION**

FIG. 1 is a front, top and left side perspective view of a fluid pressure cylinder showing a first embodiment of our new design;

FIG. 2 is a rear, bottom and right side perspective view thereof;

FIG. 3 is a front view thereof;

FIG. 4 is a rear view thereof;

FIG. 5 is a top plan view thereof;

FIG. 6 is a bottom plan view thereof;

FIG. 7 is a left side view thereof;

FIG. 8 is a right side view thereof;

FIG. 9 is a front, top and left side perspective view of a fluid pressure cylinder showing a second embodiment of our new design;

FIG. 10 is a rear, top and left side perspective view of FIG. 9;

FIG. 11 is a rear, bottom and right side perspective view of FIG. 9;

FIG. 12 is a front view of FIG. 9;

FIG. 13 is a rear view of FIG. 9;

FIG. 14 is a top plan view of FIG. 9;

FIG. 15 is a bottom plan view of FIG. 9;

FIG. 16 is a left side view of FIG. 9;

FIG. 17 is a right side view of FIG. 9;

(Continued)

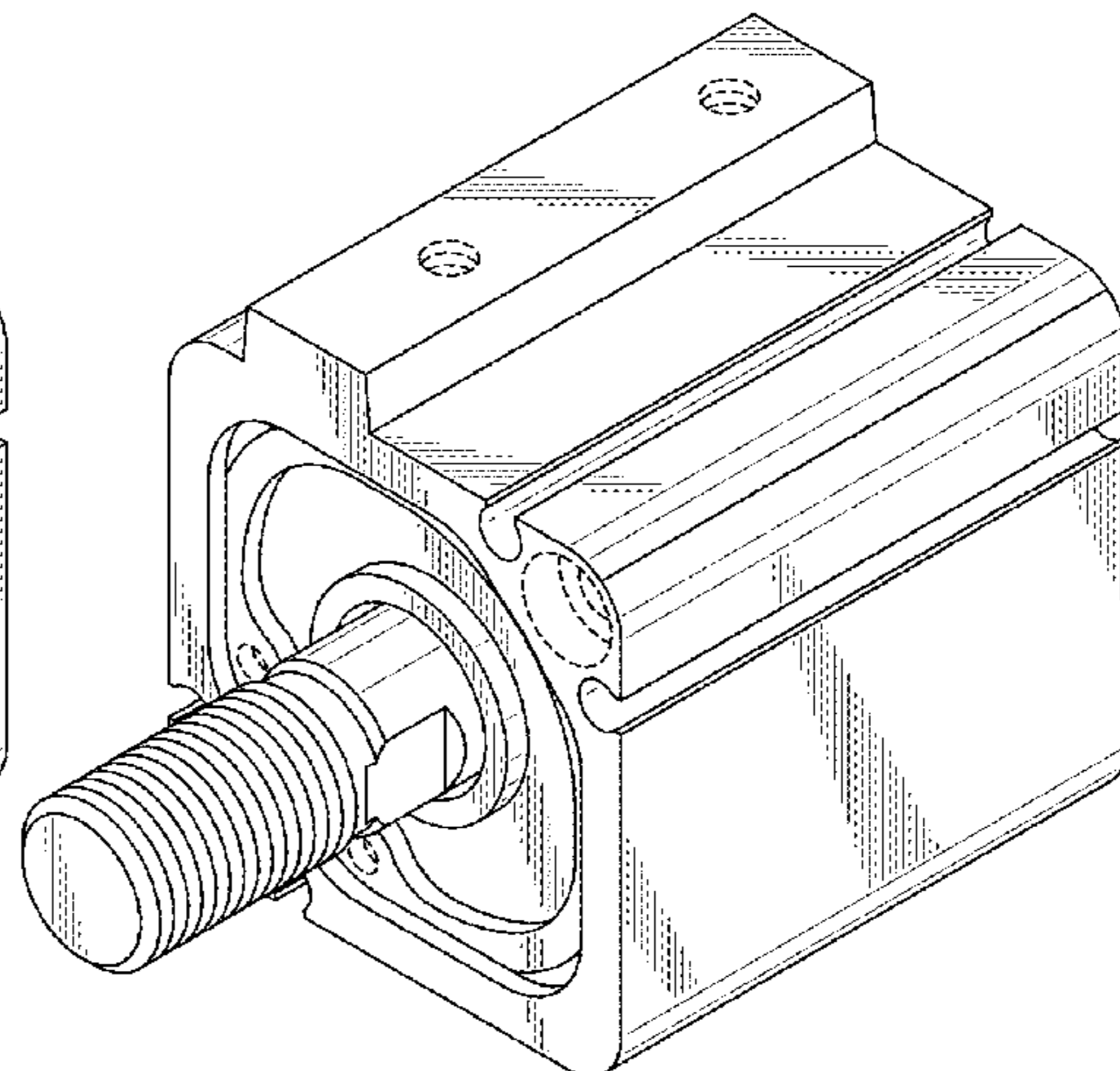
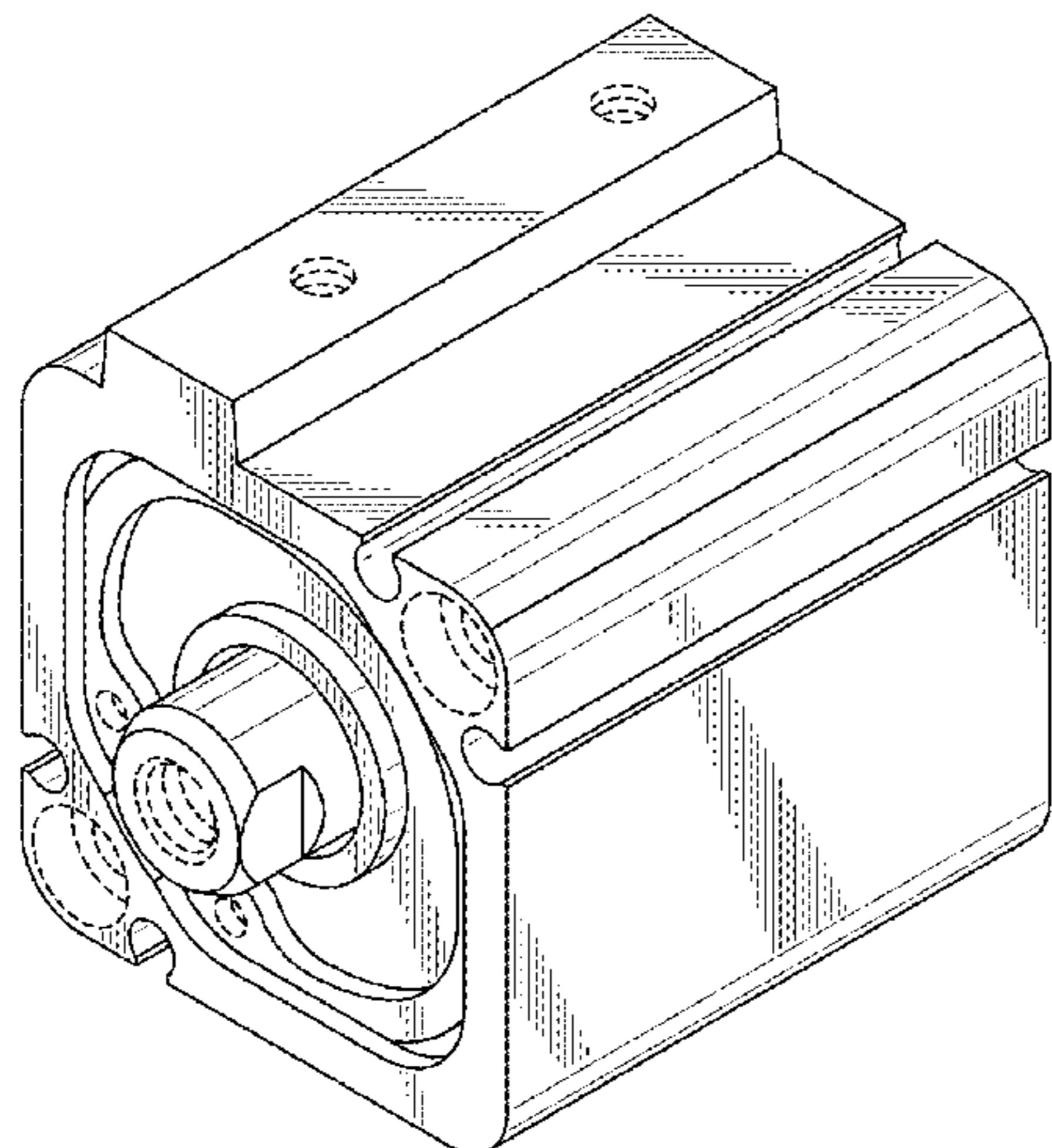

FIG. 18 is a front, top and left side perspective view of a fluid pressure cylinder showing a third embodiment of our new design;  
 FIG. 19 is a rear, bottom and right side perspective view of FIG. 18;  
 FIG. 20 is a front view of FIG. 18;  
 FIG. 21 is a rear view of FIG. 18;  
 FIG. 22 is a top plan view of FIG. 18;  
 FIG. 23 is a bottom plan view of FIG. 18;  
 FIG. 24 is a left side view of FIG. 18;  
 FIG. 25 is a right side view of FIG. 18;  
 FIG. 26 is a front, top and left side perspective view of a fluid pressure cylinder showing a fourth embodiment of our new design;  
 FIG. 27 is a rear, top and left side perspective view of FIG. 26;  
 FIG. 28 is a rear, bottom and right side perspective view of FIG. 26;  
 FIG. 29 is a front view of FIG. 26;  
 FIG. 30 is a rear view of FIG. 26;  
 FIG. 31 is a top plan view of FIG. 26;  
 FIG. 32 is a bottom plan view of FIG. 26;  
 FIG. 33 is a left side view of FIG. 26; and,  
 FIG. 34 is a right side view of FIG. 26.  
 The broken lines depict portions of the fluid pressure cylinder that form no part of the claimed design.

**1 Claim, 34 Drawing Sheets**

(58) **Field of Classification Search**

CPC .... F02M 37/04; F02M 31/14; F04D 29/4286;  
 F15B 15/14; F15B 15/16; F15B 15/26;  
 F15B 15/1919; F15B 15/1414; F15B  
 15/00; F15B 15/08

See application file for complete search history.

(56) **References Cited**

U.S. PATENT DOCUMENTS

D303,393 S \* 9/1989 Stoll ..... D15/7  
 5,163,351 A \* 11/1992 Dominka ..... F15B 15/26  
 251/31  
 D333,474 S \* 2/1993 Aizawa ..... D15/5  
 D370,683 S \* 6/1996 Stahlman ..... D15/7  
 5,555,789 A \* 9/1996 Rosengren ..... F15B 15/082  
 384/57  
 D417,457 S \* 12/1999 Asahara ..... D15/7  
 D420,683 S \* 2/2000 Suzuki ..... D15/7  
 D428,617 S \* 7/2000 Hariwara ..... D15/7  
 6,089,111 A \* 7/2000 Machijima ..... G01D 11/30  
 73/866.5  
 6,152,015 A \* 11/2000 Migliori ..... F15B 15/1419  
 92/177  
 D445,704 S \* 7/2001 Suzuki ..... D10/85  
 D480,405 S \* 10/2003 Kleffmann ..... D15/143  
 D499,348 S \* 12/2004 Matsumoto ..... D10/85

D500,258 S \* 12/2004 Kita ..... D10/85  
 D500,259 S \* 12/2004 Kita ..... D10/85  
 D572,282 S \* 7/2008 Yaegashi ..... D15/143  
 D575,175 S \* 8/2008 Suzuki ..... D10/85  
 D584,324 S \* 1/2009 Yaegashi ..... D15/143  
 D600,534 S \* 9/2009 Tokumoto ..... D8/354  
 D669,097 S \* 10/2012 Hariwara ..... D15/7  
 D669,098 S \* 10/2012 Hariwara ..... D15/7  
 D682,901 S \* 5/2013 Peschel ..... D15/143  
 D685,014 S \* 6/2013 Mangold ..... D15/143  
 D685,403 S \* 7/2013 Mangold ..... D15/143  
 D687,516 S \* 8/2013 Asaba ..... D23/233  
 D689,524 S \* 9/2013 Peschel ..... D15/7  
 D689,525 S \* 9/2013 Peschel ..... D15/7  
 D699,759 S \* 2/2014 Peschel ..... D15/7  
 D699,760 S \* 2/2014 Peschel ..... D15/7  
 D699,761 S \* 2/2014 Peschel ..... D15/7  
 D757,120 S \* 5/2016 Kudo ..... D15/7  
 D760,805 S \* 7/2016 Monden ..... D15/7  
 D770,595 S \* 11/2016 Suzuki ..... D23/233  
 D772,302 S \* 11/2016 Kudo ..... D15/7  
 D780,228 S \* 2/2017 Kudo ..... D15/7  
 D780,229 S \* 2/2017 Kudo ..... D15/7  
 D794,164 S \* 8/2017 Suzuki ..... D23/233  
 D805,559 S \* 12/2017 Kudo ..... D15/7  
 D805,560 S \* 12/2017 Kudo ..... D15/7  
 D819,700 S \* 6/2018 Kudo ..... D15/7  
 D820,321 S \* 6/2018 Kudo ..... D15/7  
 D825,616 S \* 8/2018 Monden ..... D15/9  
 D826,285 S \* 8/2018 Yaegashi ..... D15/9  
 D871,457 S \* 12/2019 Ikari ..... D15/7  
 D888,769 S \* 6/2020 Mizutani ..... D15/7  
 D888,770 S \* 6/2020 Mizutani ..... D15/7  
 D888,771 S \* 6/2020 Mizutani ..... D15/7  
 D888,772 S \* 6/2020 Sato ..... D15/7  
 D888,773 S \* 6/2020 Sato ..... D15/7  
 D888,774 S \* 6/2020 Asahara ..... D15/7  
 D888,775 S \* 6/2020 Sato ..... D15/7  
 D890,213 S \* 7/2020 Sato ..... D15/7  
 D890,214 S \* 7/2020 Sato ..... D15/7  
 D890,215 S \* 7/2020 Sato ..... D15/7  
 D892,980 S \* 8/2020 Sato ..... D23/233  
 D894,965 S \* 9/2020 Nagai ..... D15/7  
 D899,466 S \* 10/2020 Nemoto ..... D15/7  
 2011/0126703 A1 \* 6/2011 Terasaki ..... F15B 15/2892  
 92/5 R  
 2017/0298931 A1 \* 10/2017 Kudo ..... F15B 15/2861  
 2020/0109782 A1 \* 4/2020 Odaka ..... F15B 15/14  
 2020/0300276 A1 \* 9/2020 Tamura ..... F15B 15/14

FOREIGN PATENT DOCUMENTS

JP 846878 S 9/1992  
 JP 110350 S 6/2001  
 JP 1615185 S 10/2018

OTHER PUBLICATIONS

SMC, C(D)QX, Compact Cylinder, Double Acting, Single Rod, Low Speed, (site visited Nov. 14, 2020), SCM USA website, URL:<[https://www.smcusa.com/products/C\(D\)QX-Compact-Cylinder-Double-Acting-Single-Rod-Low-Speed-53749](https://www.smcusa.com/products/C(D)QX-Compact-Cylinder-Double-Acting-Single-Rod-Low-Speed-53749)> (Year: 2020).\*

\* cited by examiner

FIG. 1

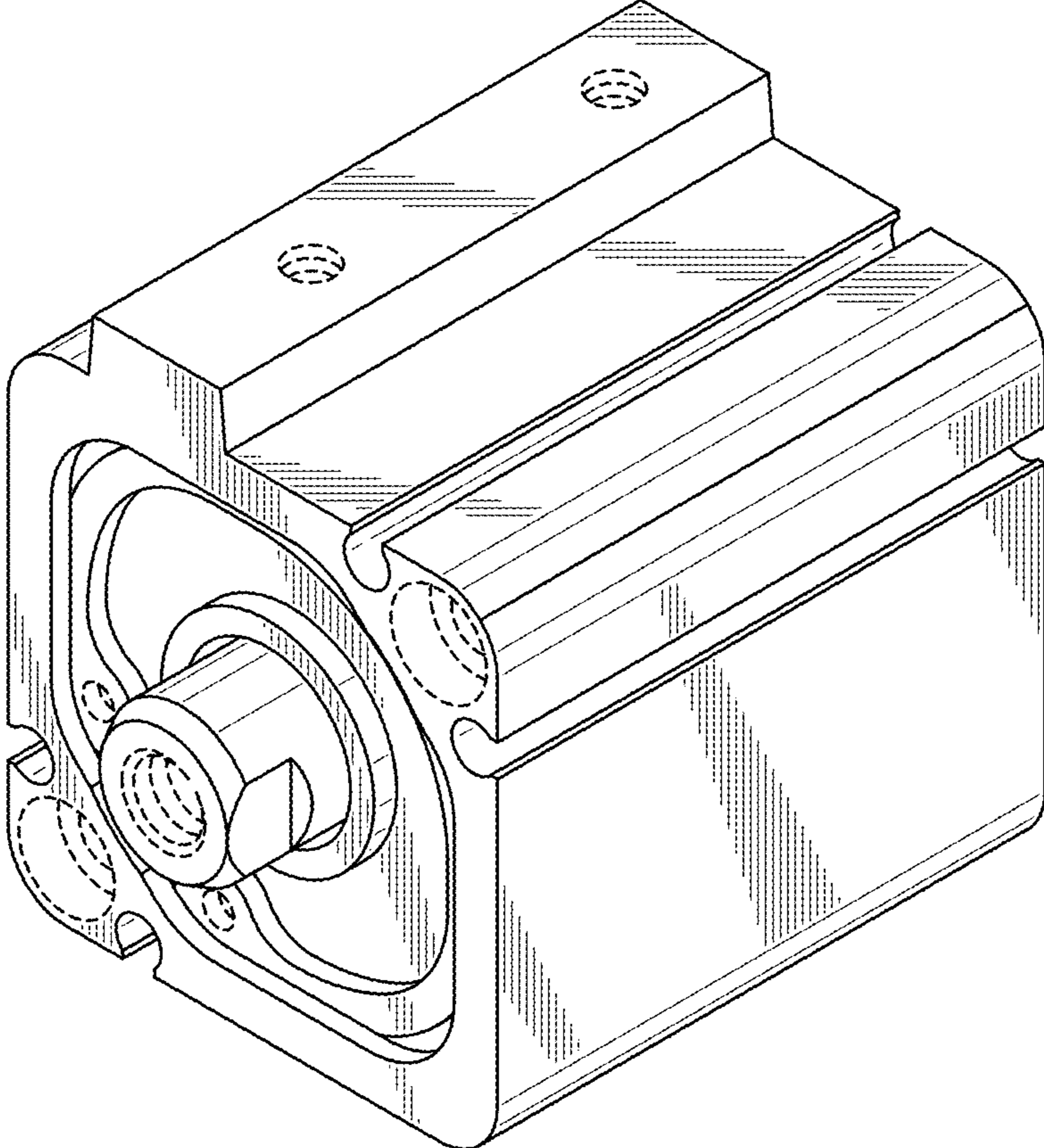

FIG. 2

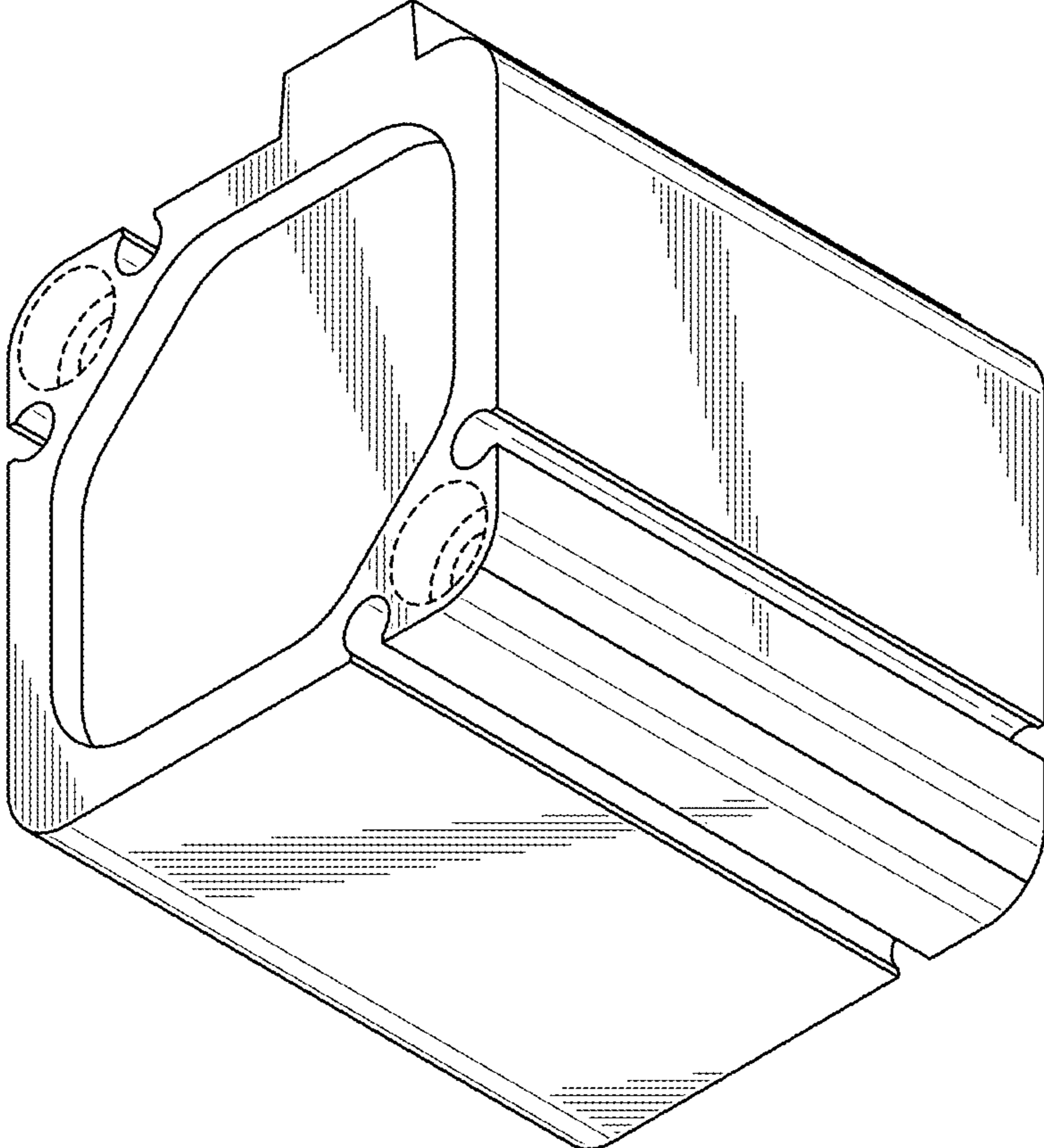

FIG. 3

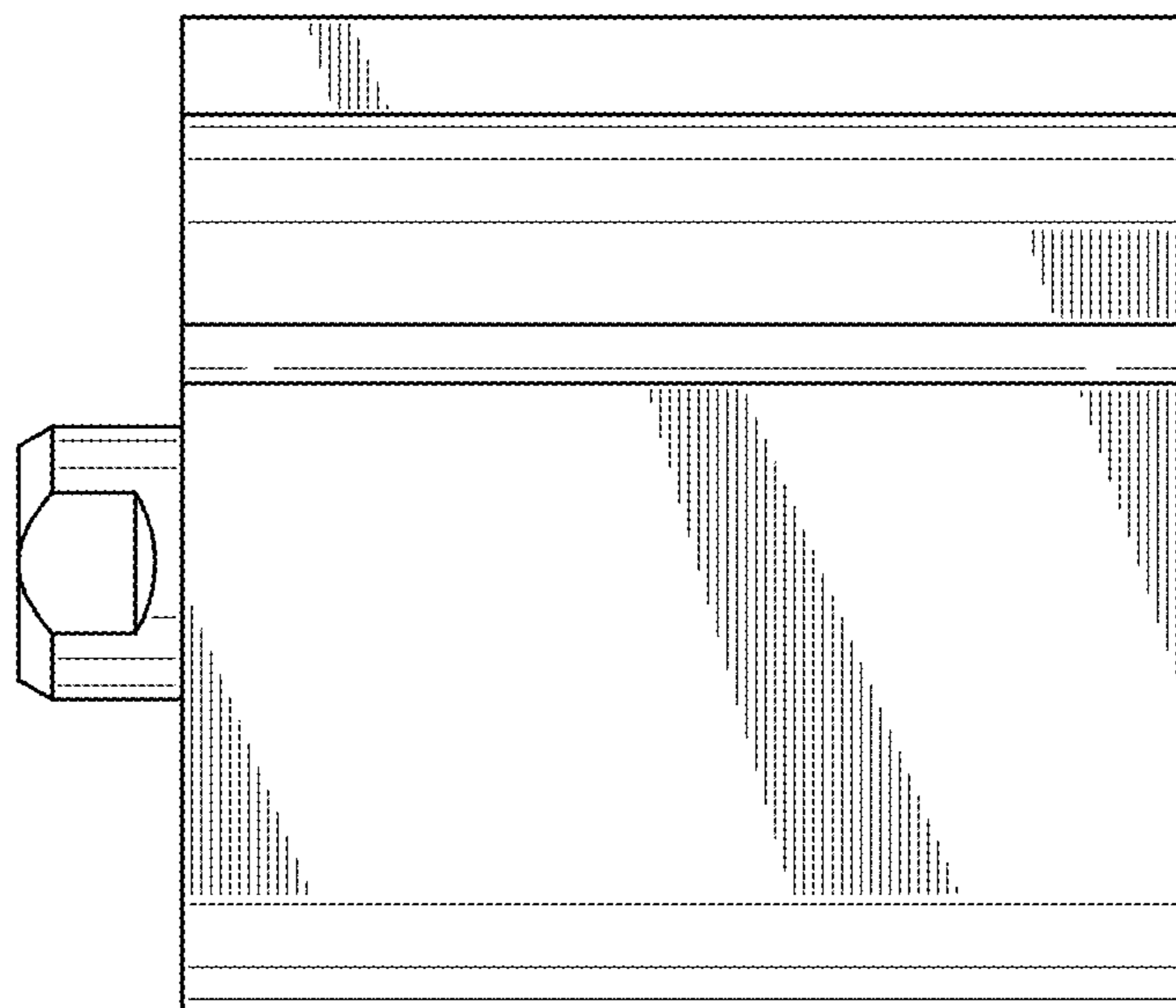

FIG. 4

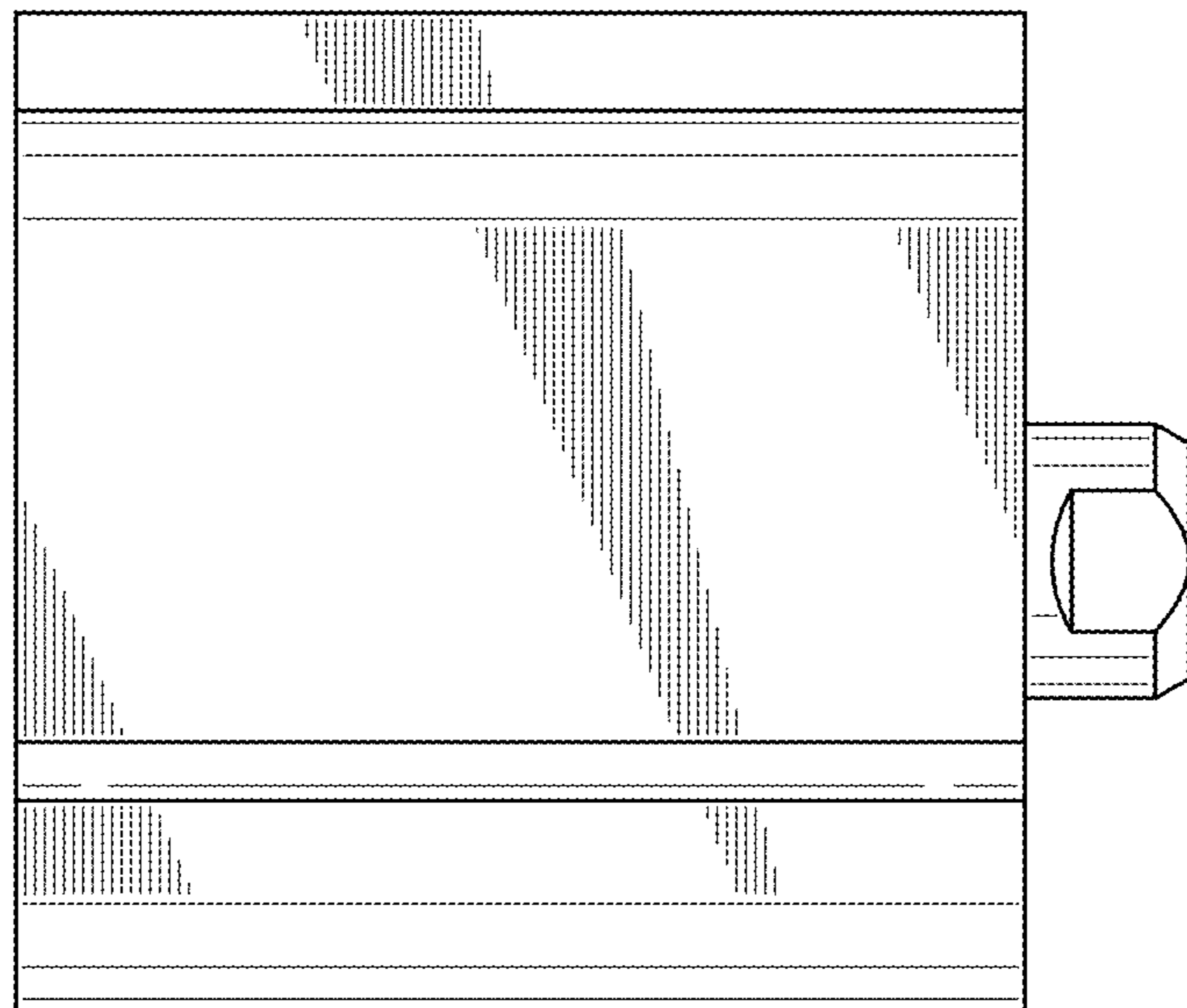

FIG. 5

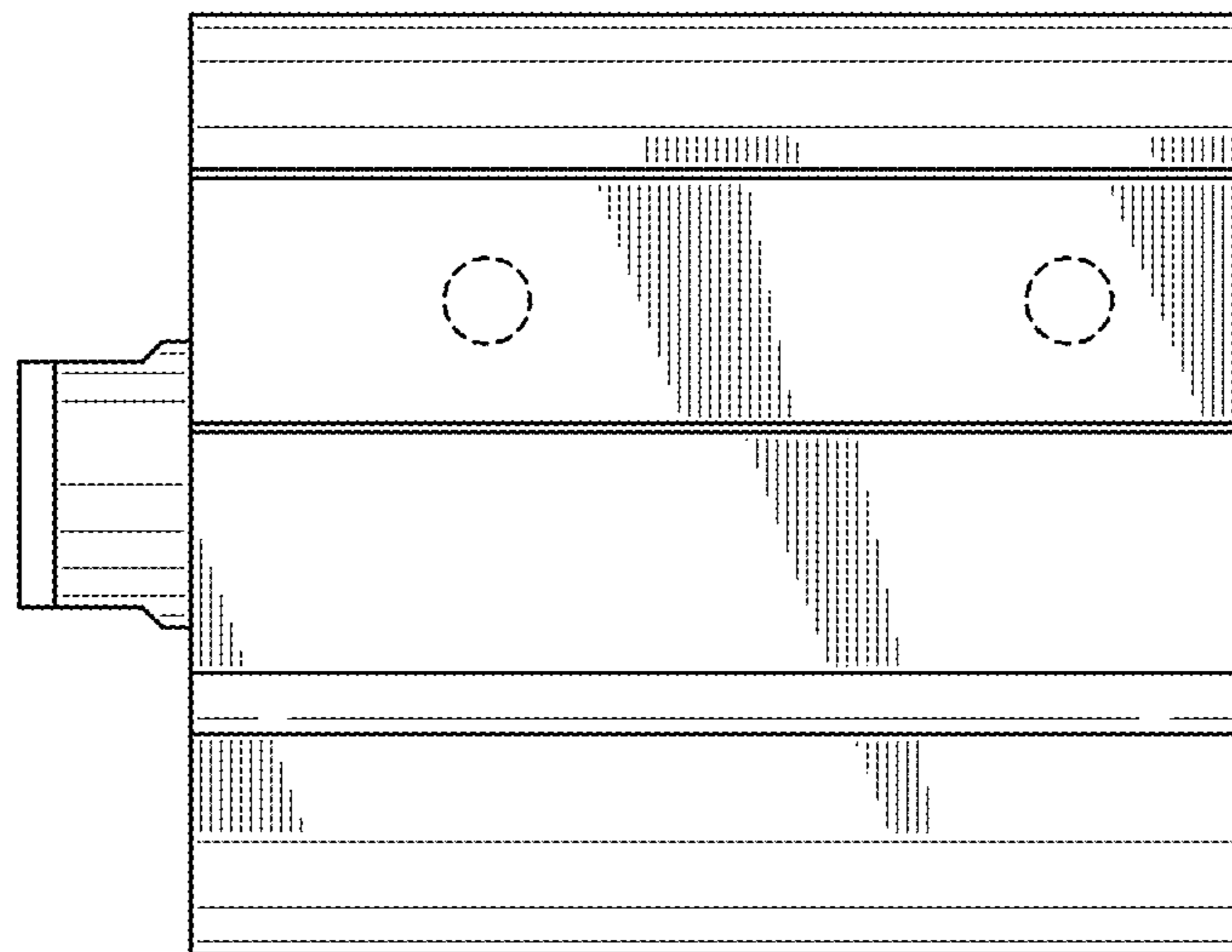

FIG. 6

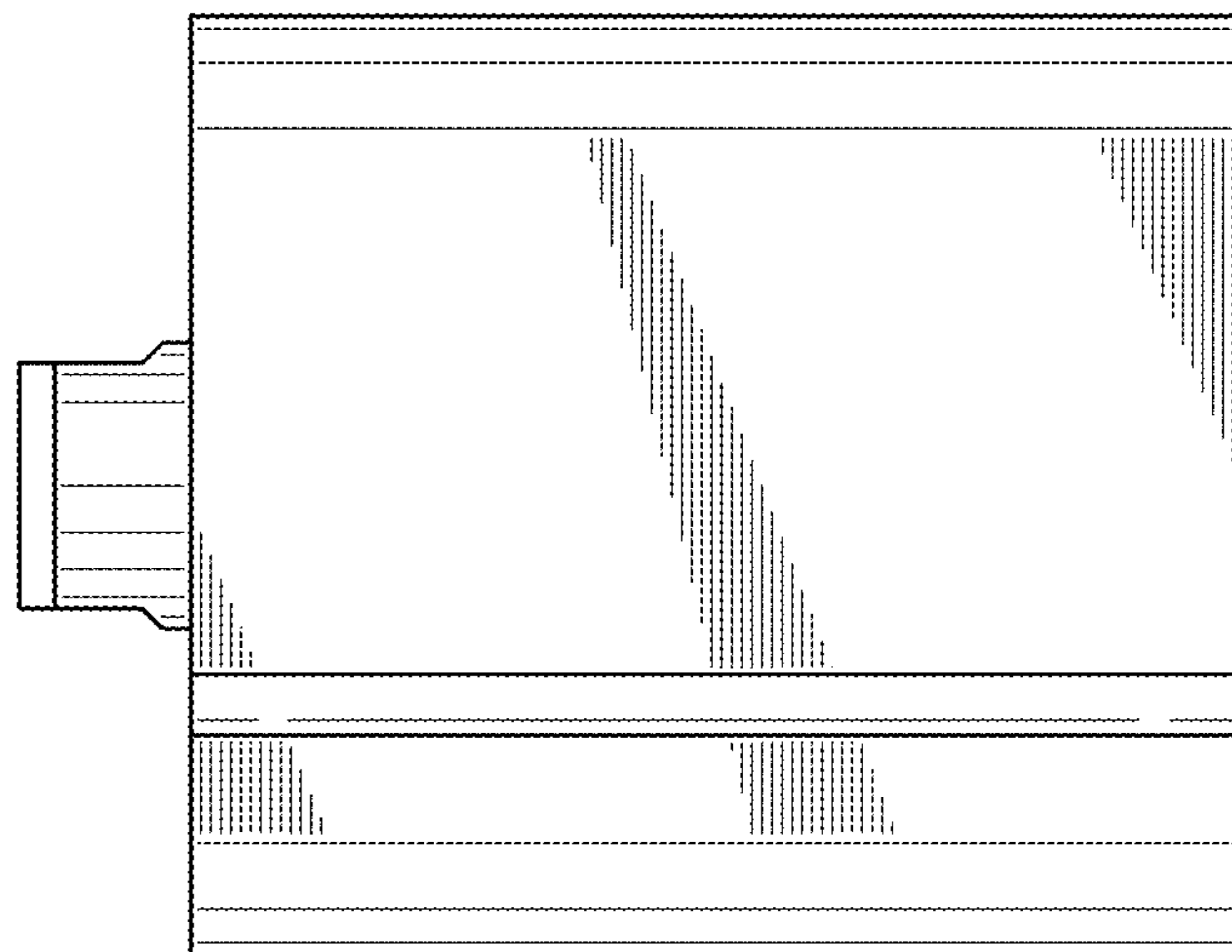



FIG. 7

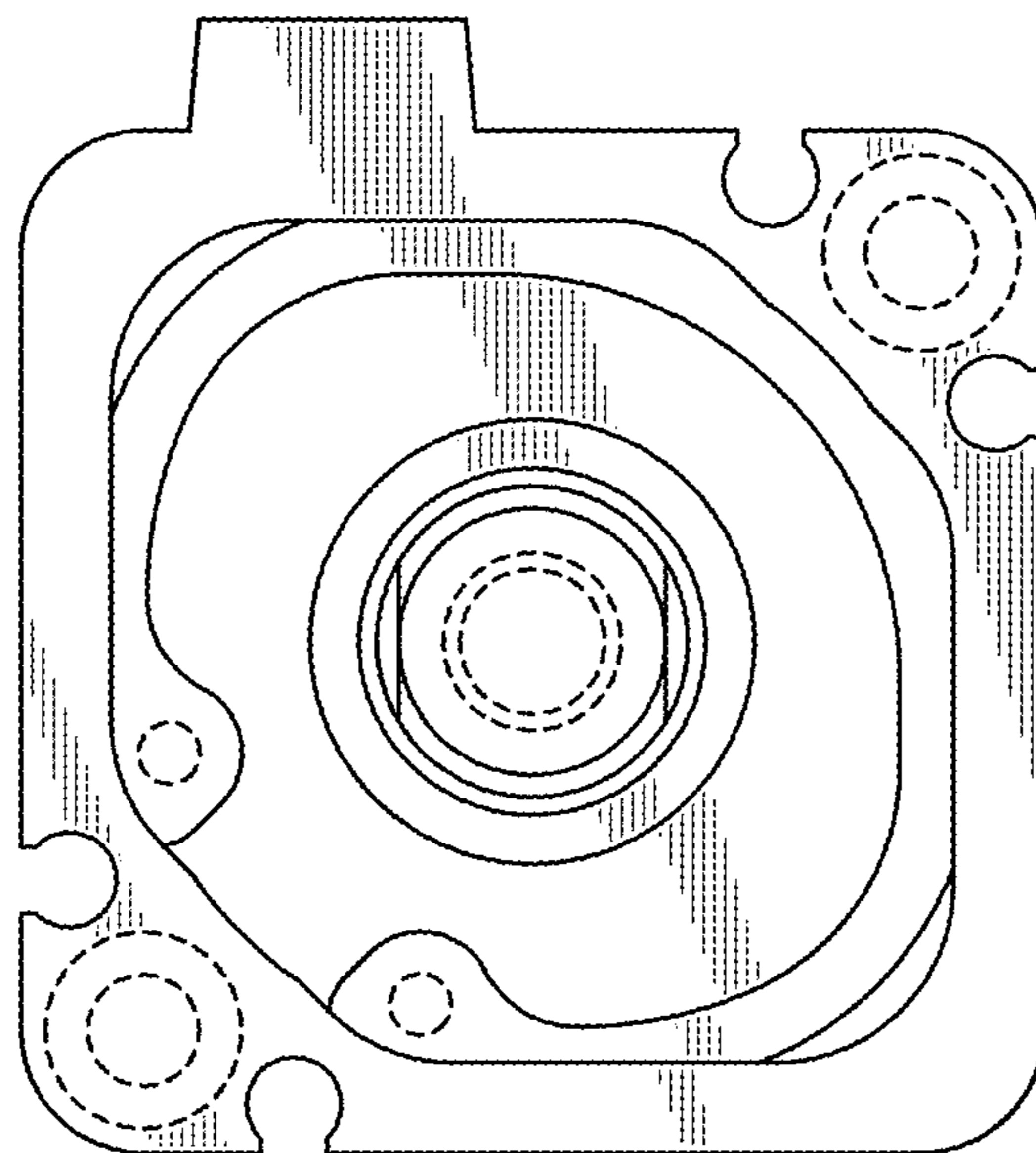

FIG. 8

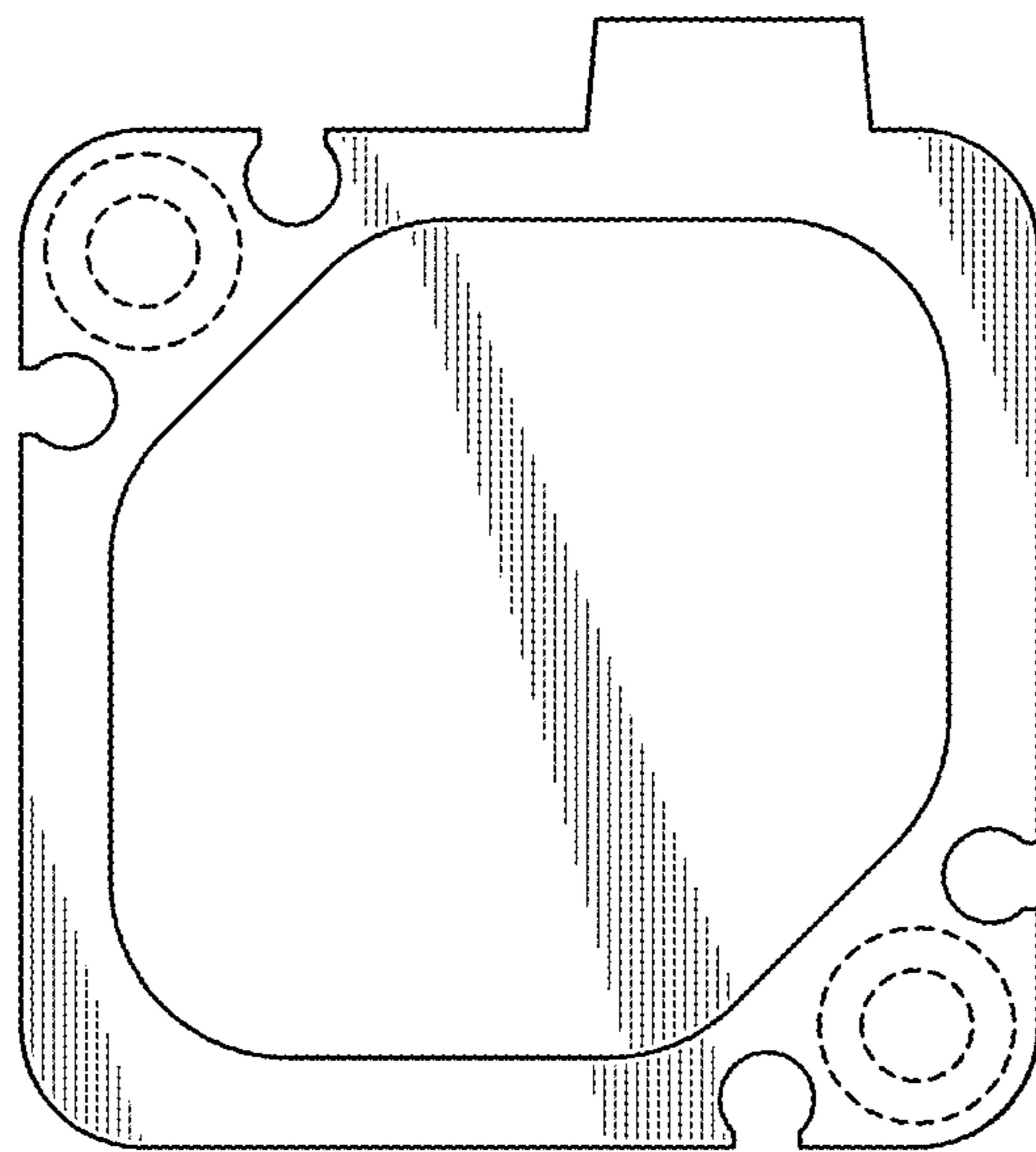

FIG. 9

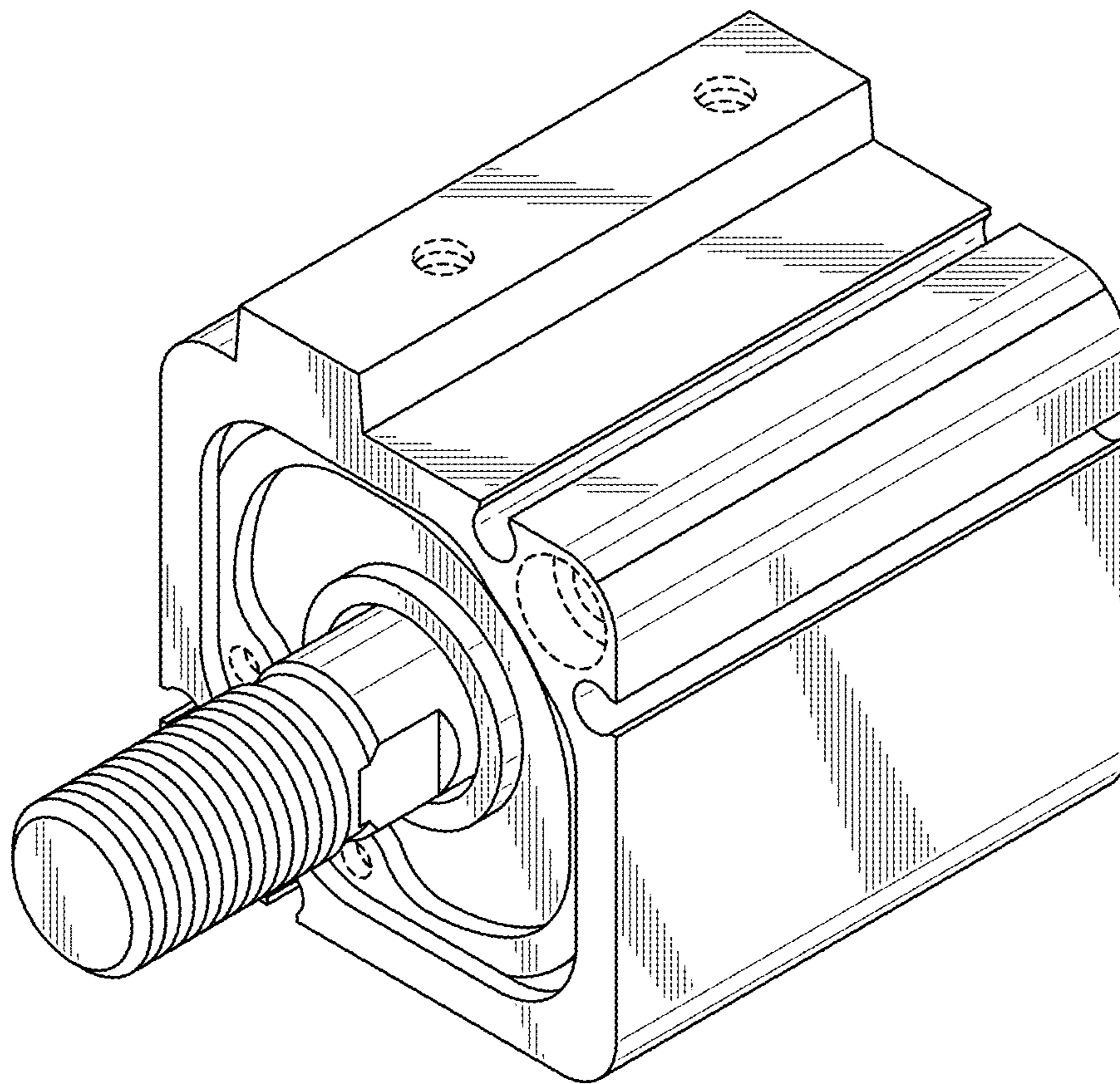

FIG. 10

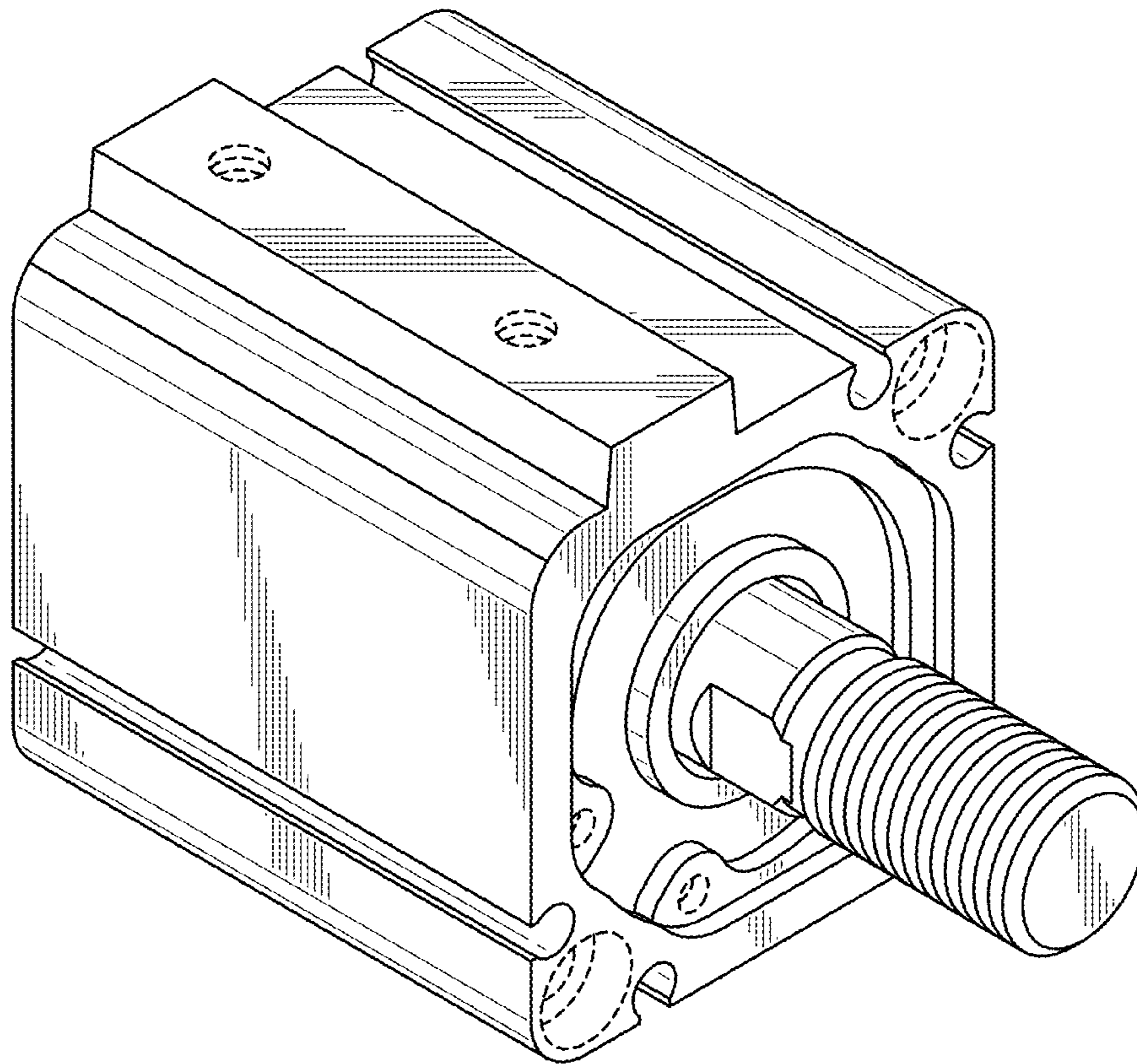

FIG. 11

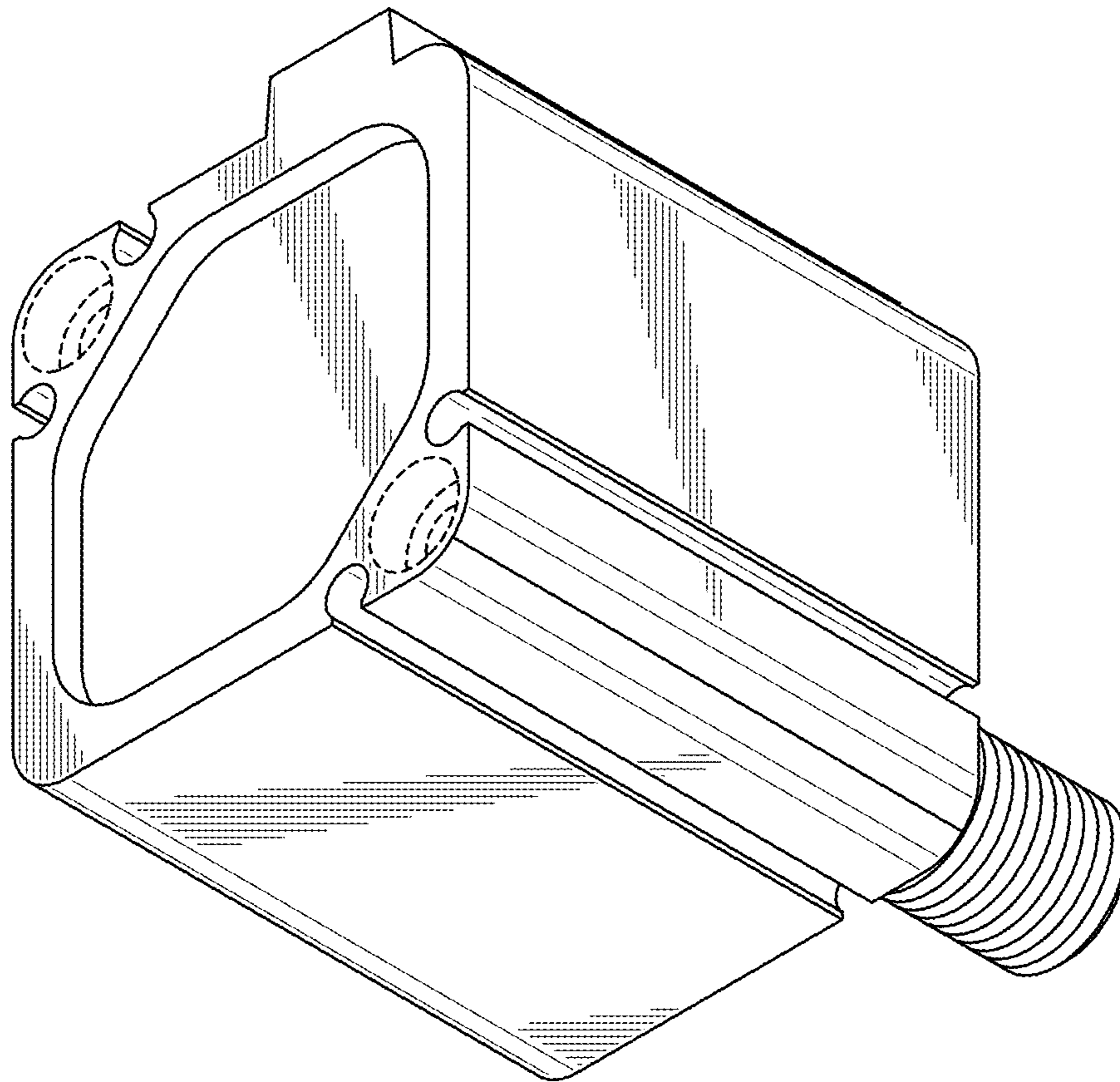

FIG. 12

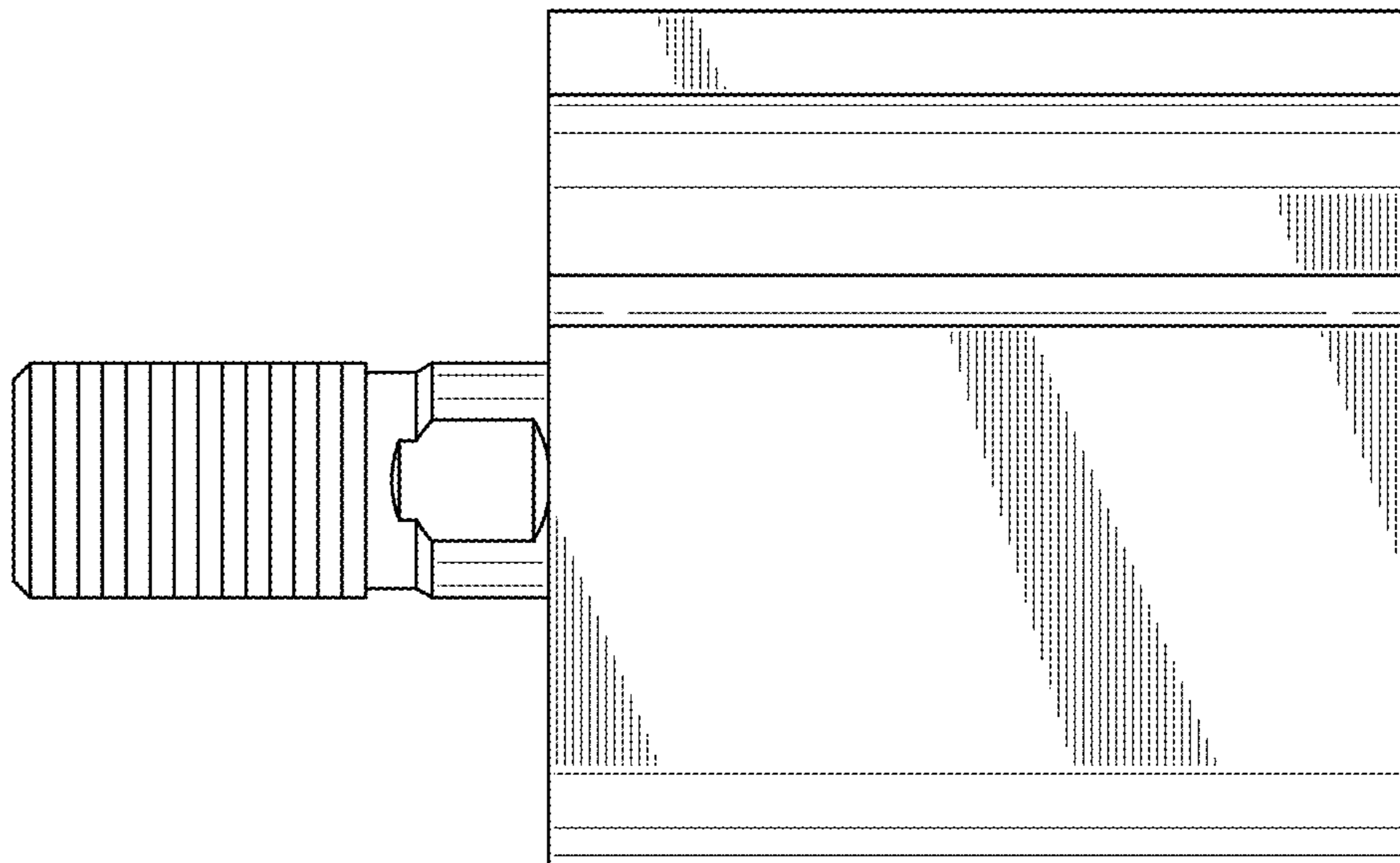

FIG. 13

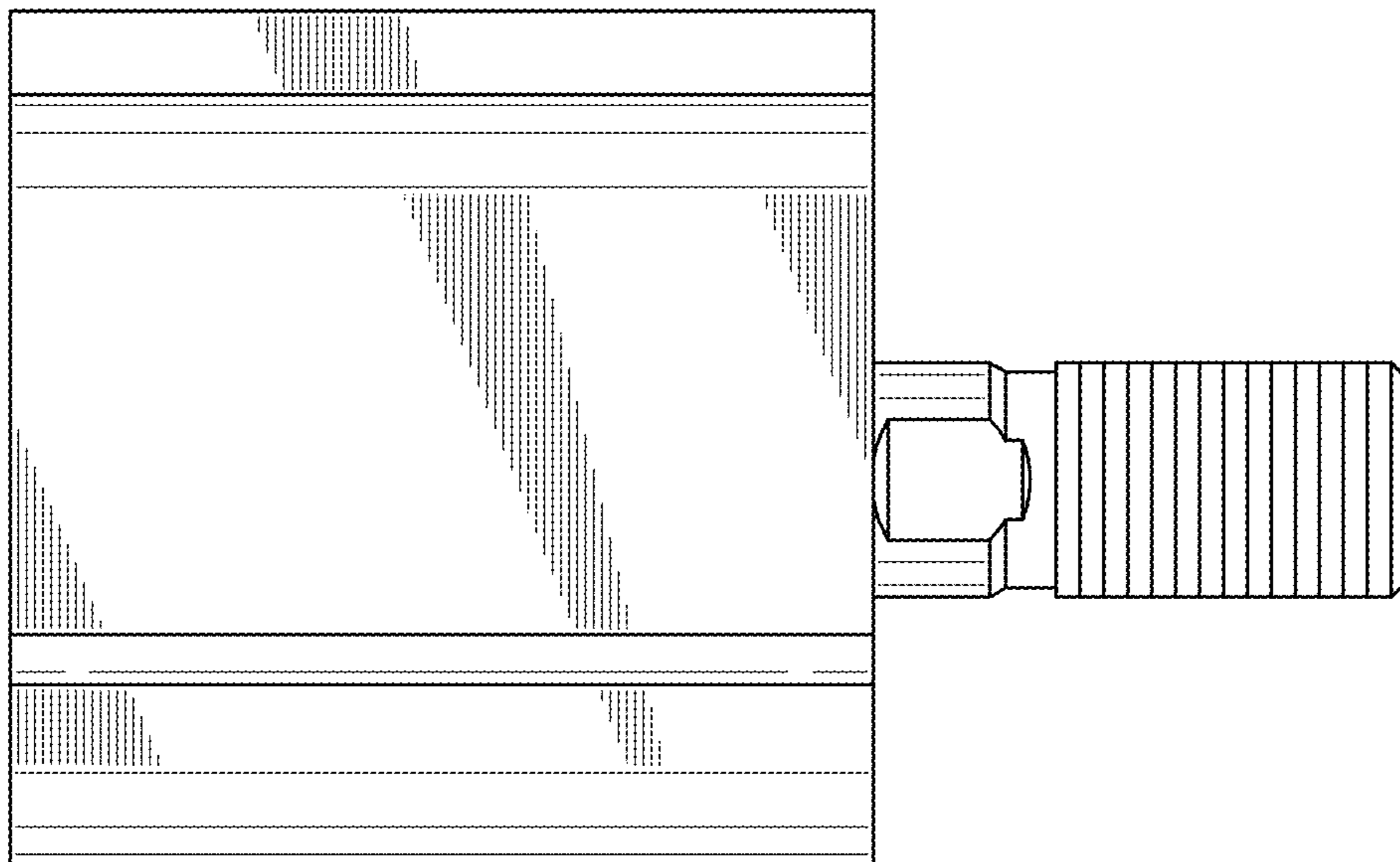

FIG. 14

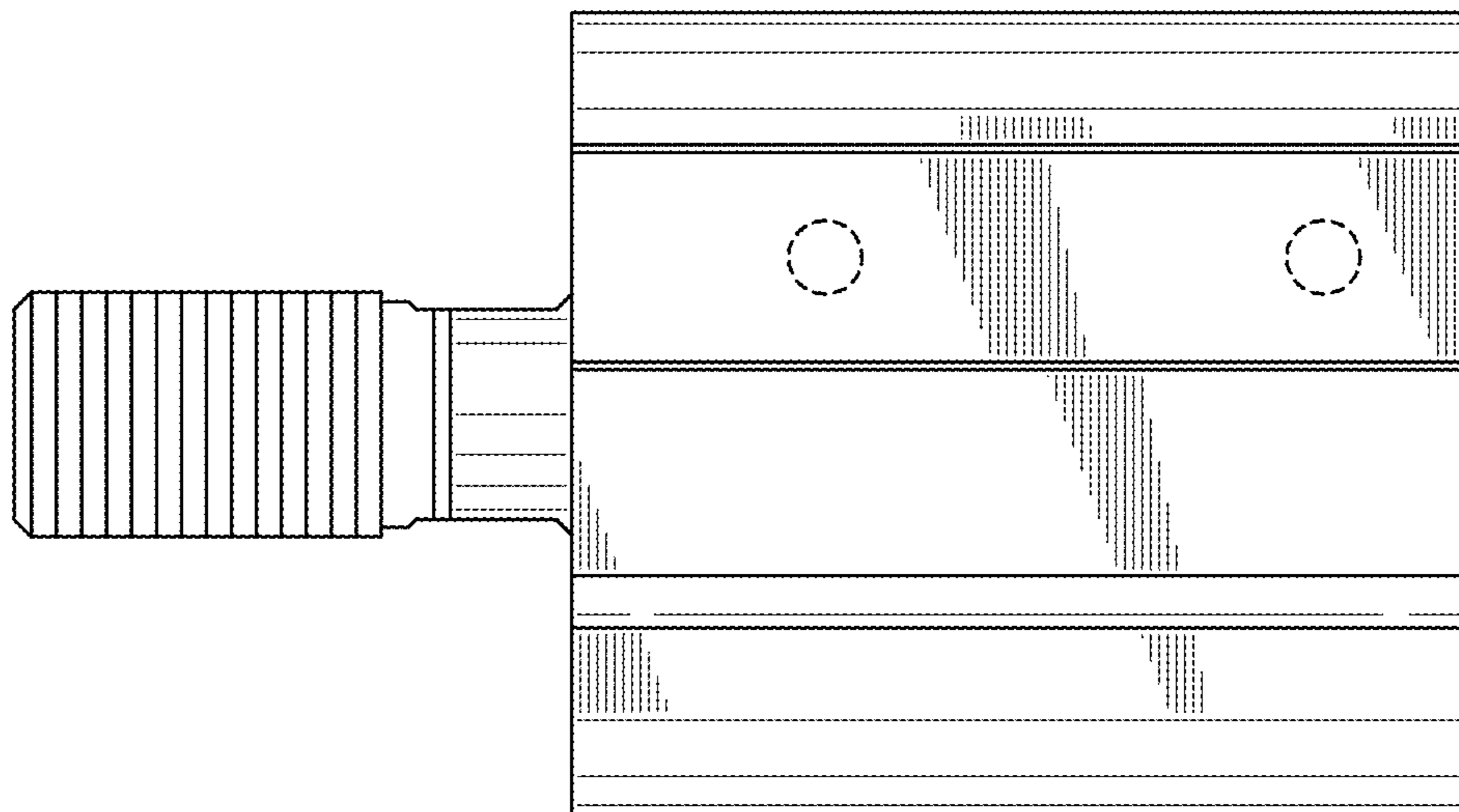



FIG. 15

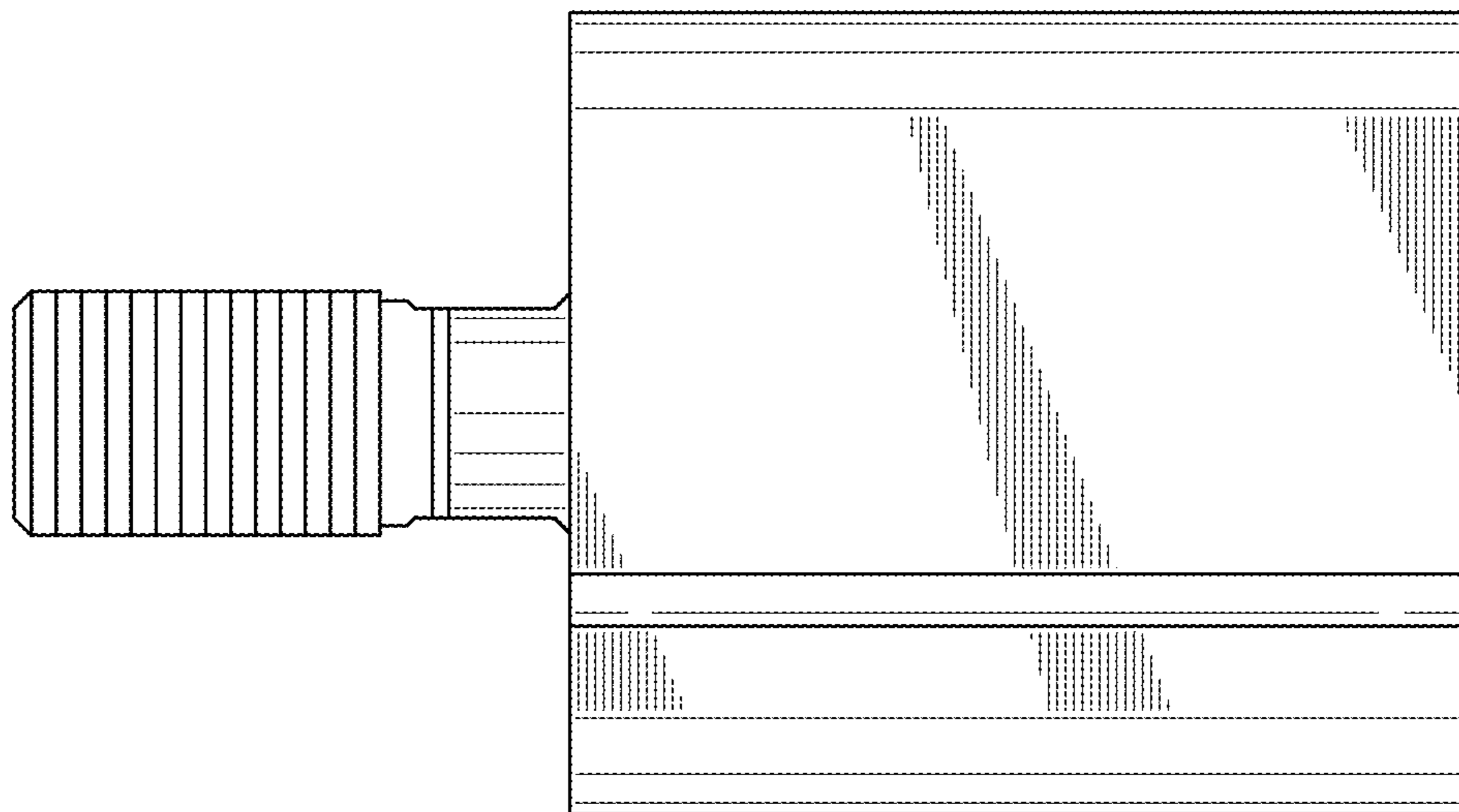

FIG. 16

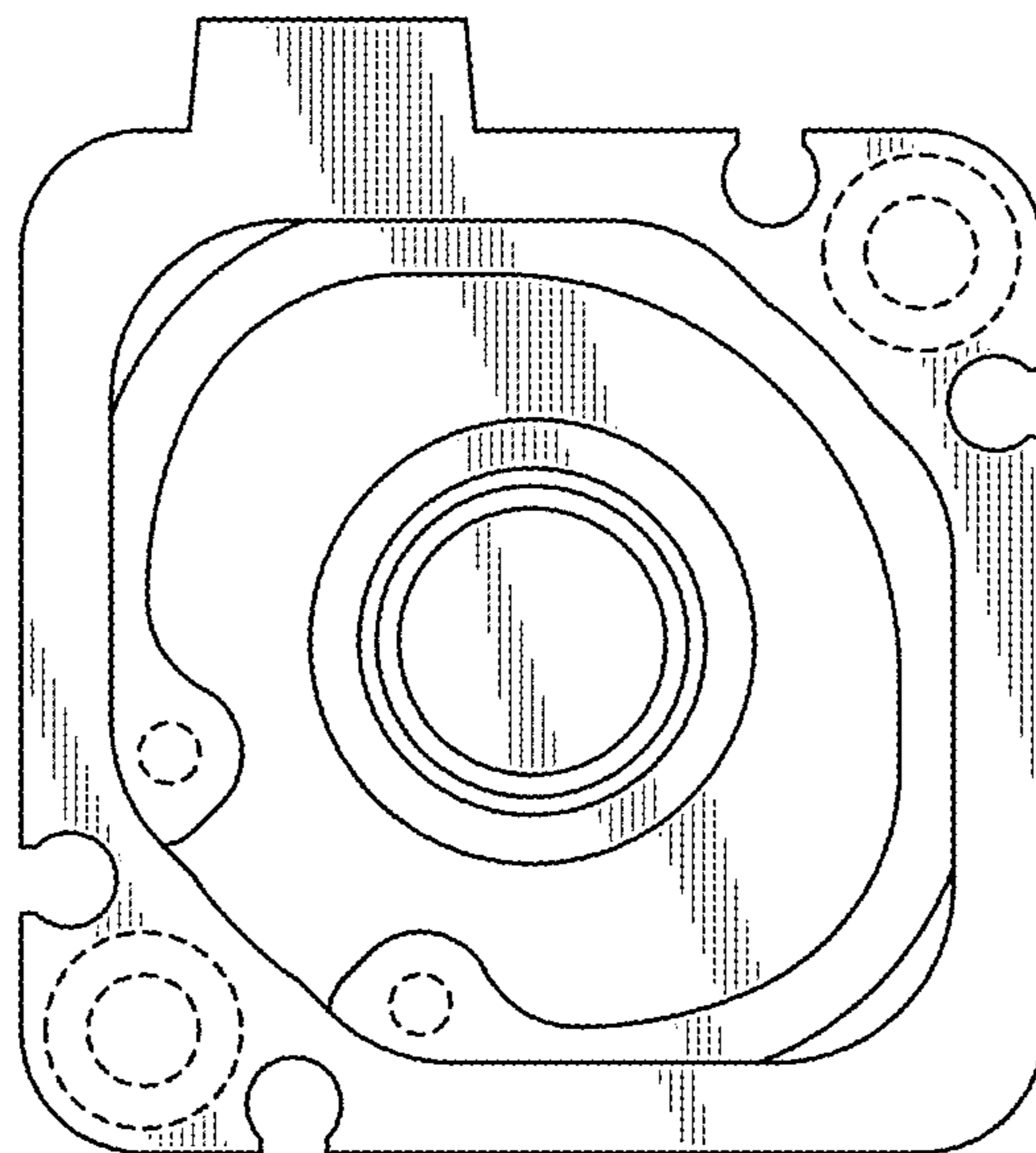

FIG. 17

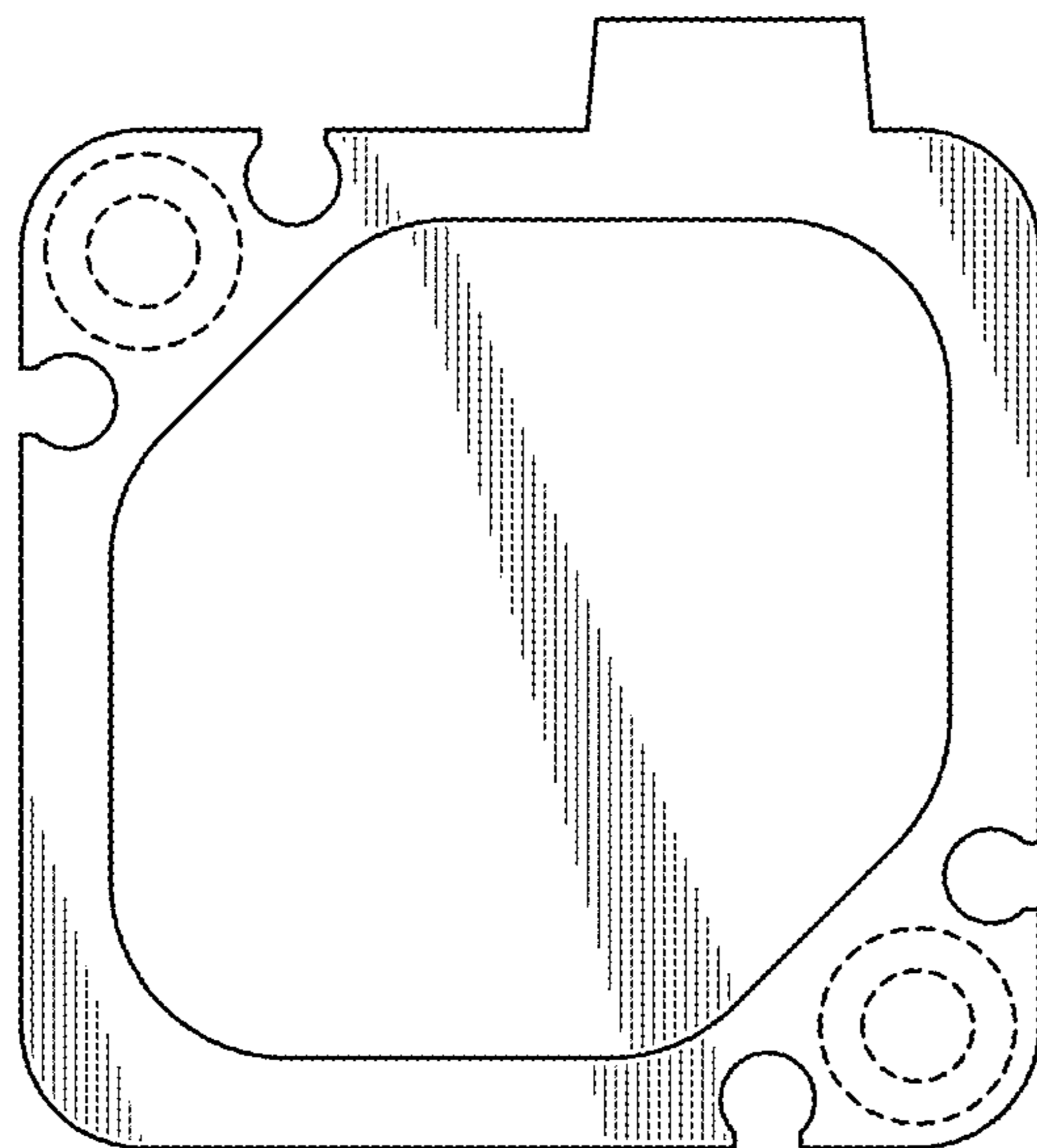

FIG. 18

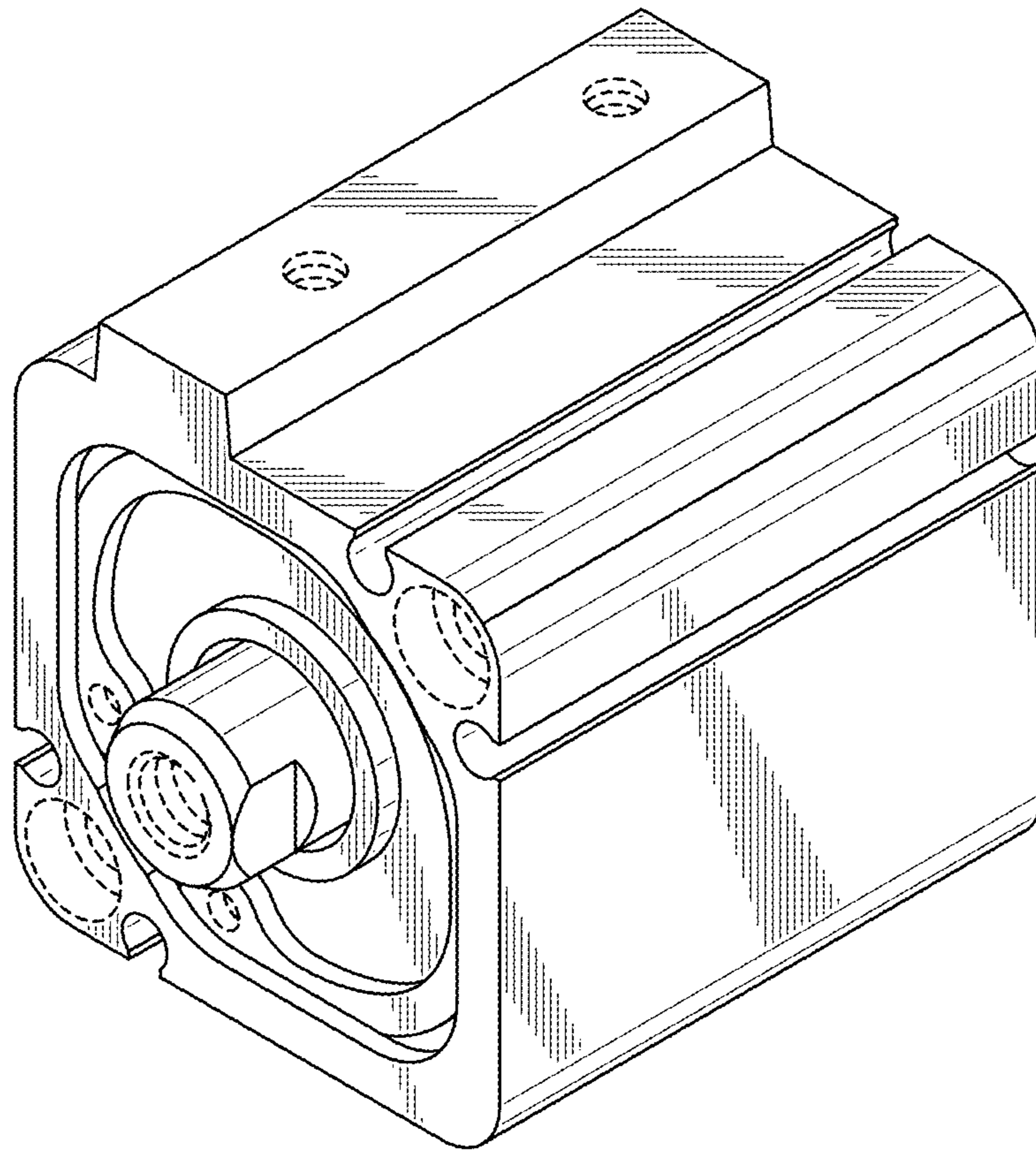

FIG. 19

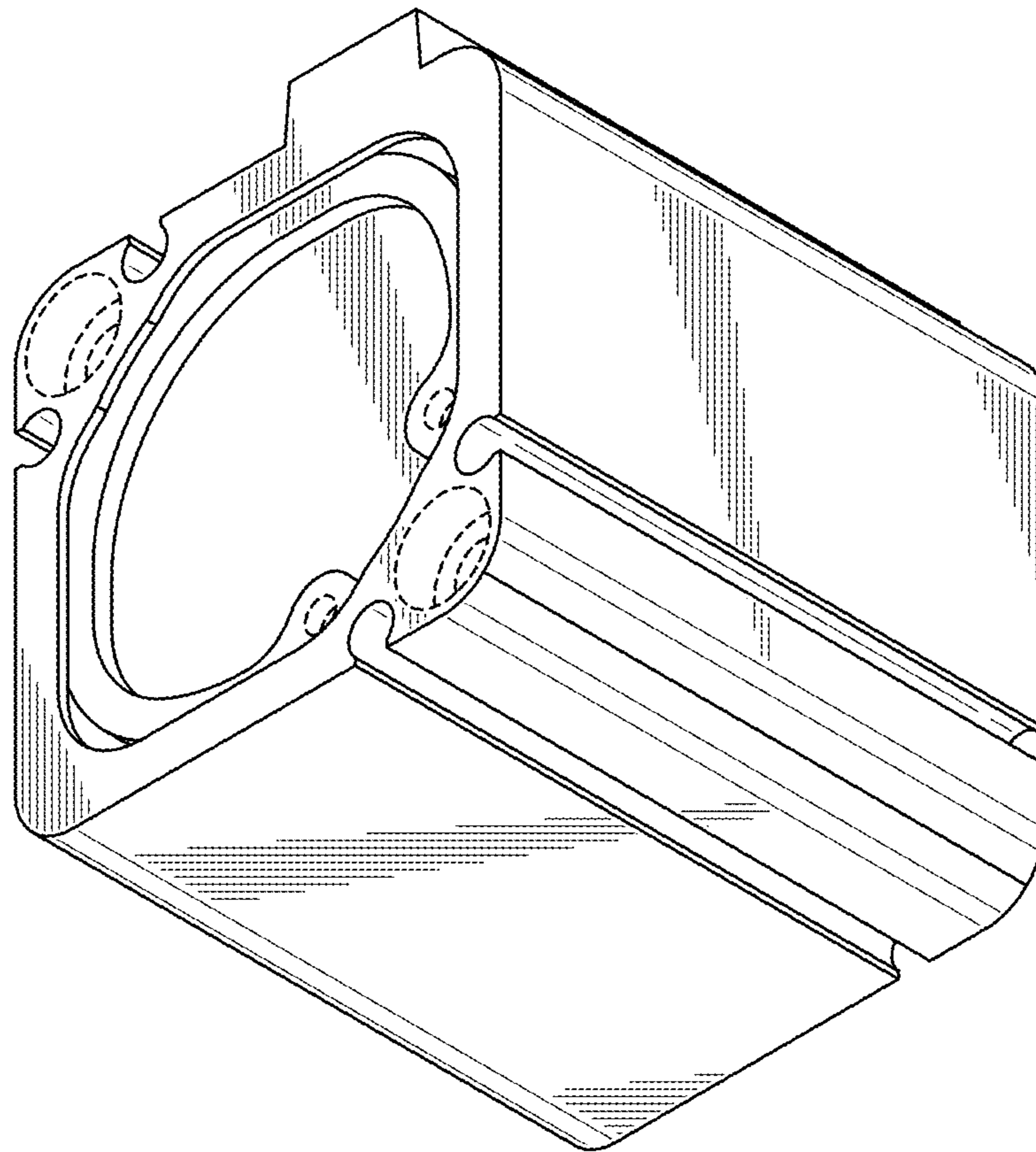

FIG. 20

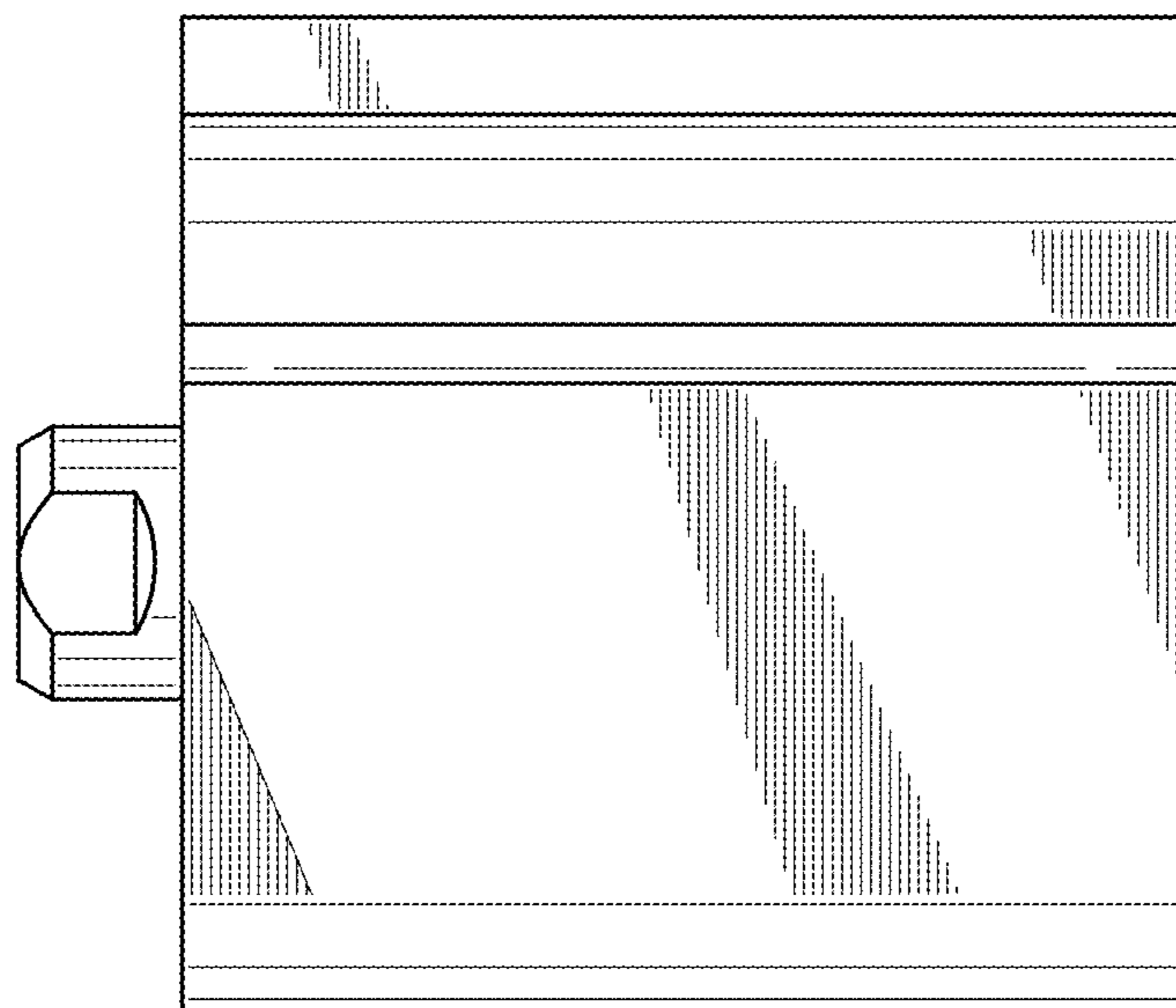

FIG. 21

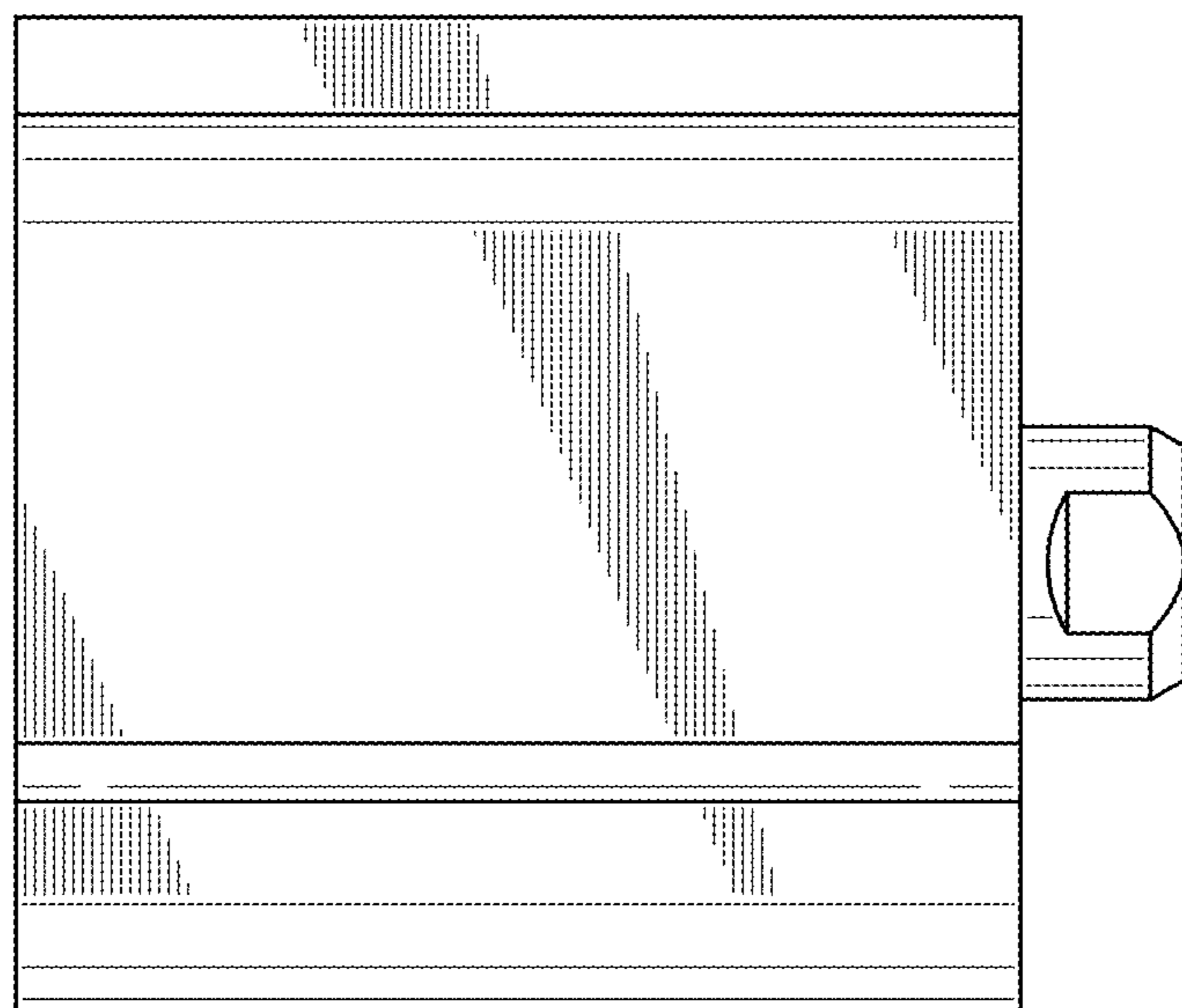

FIG. 22

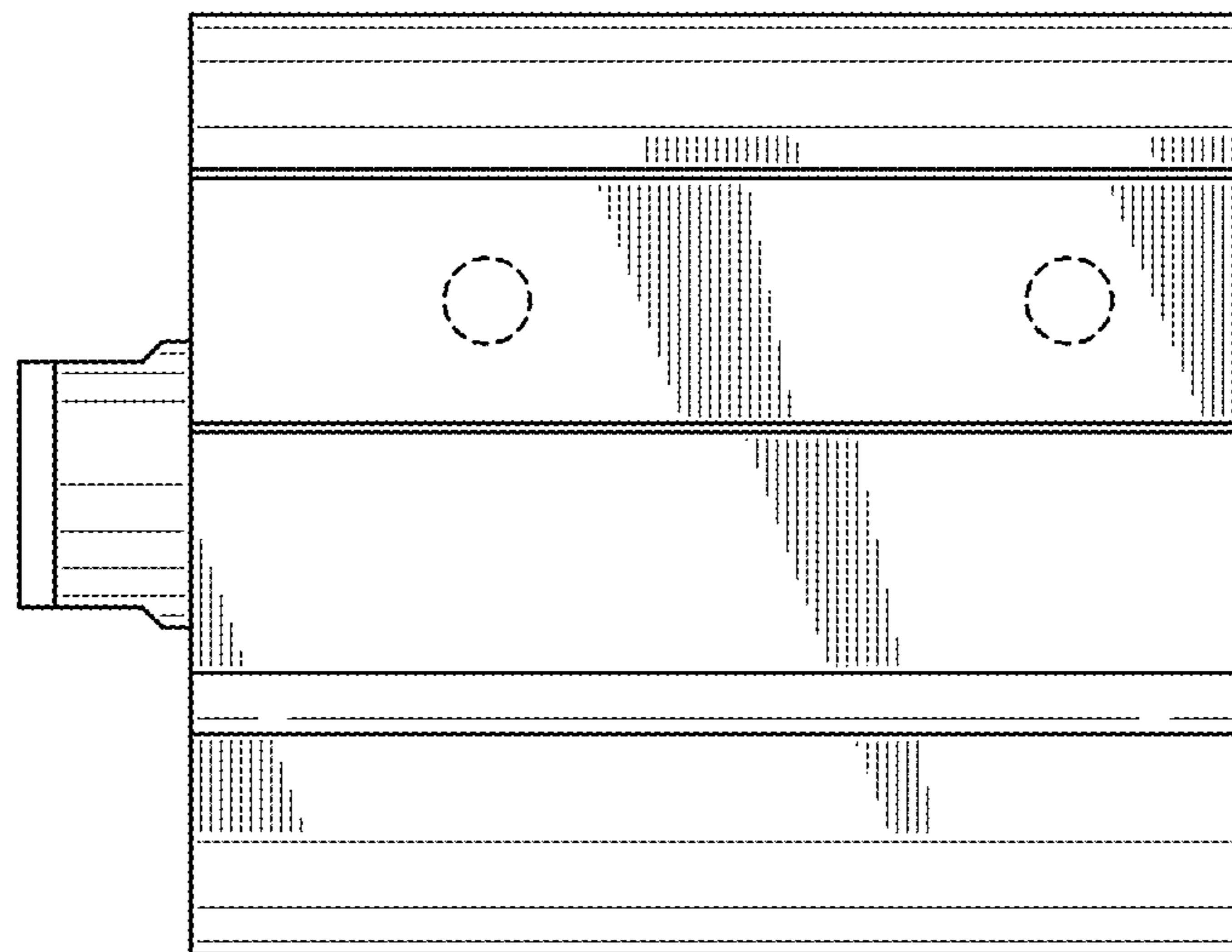



FIG. 23

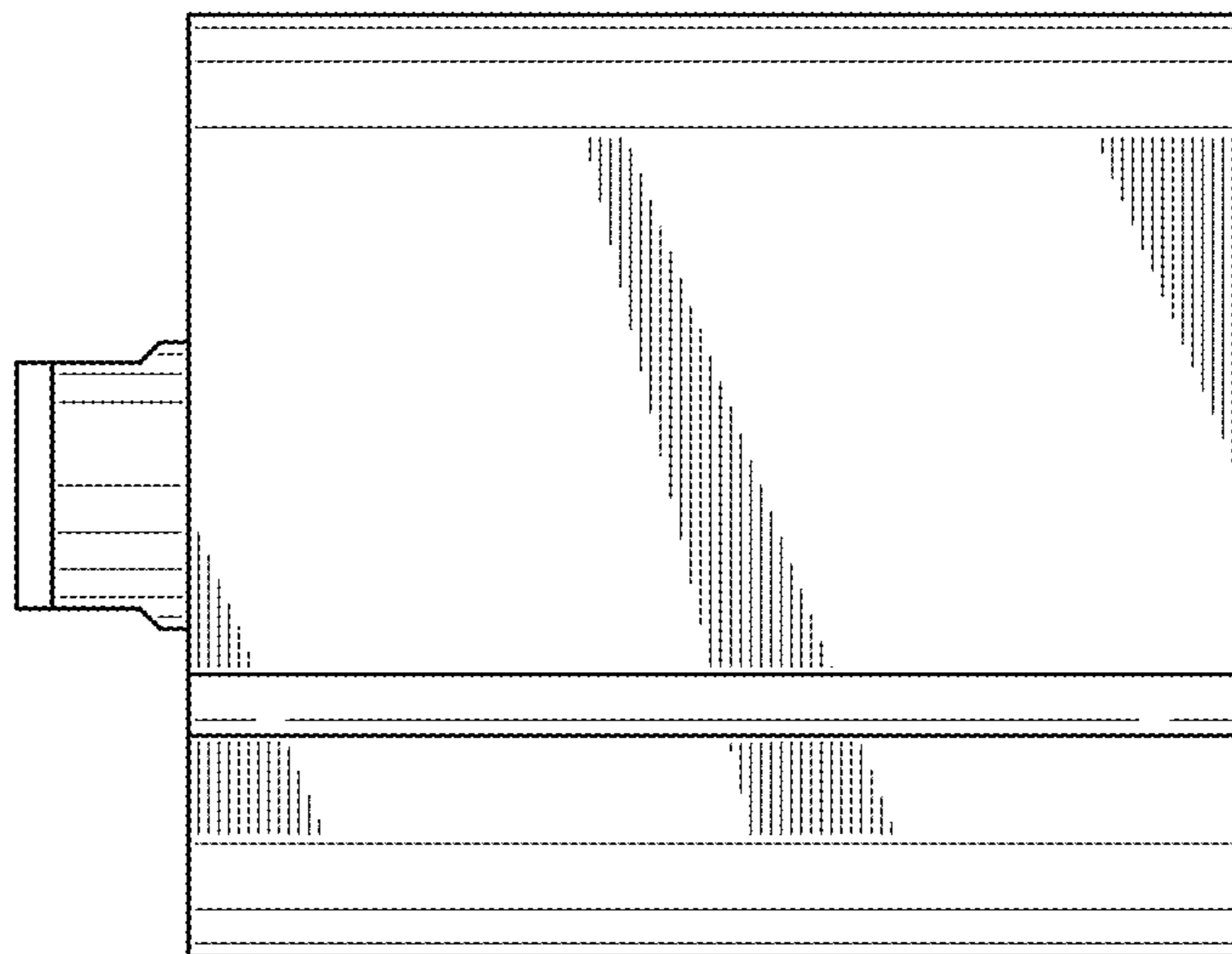

FIG. 24

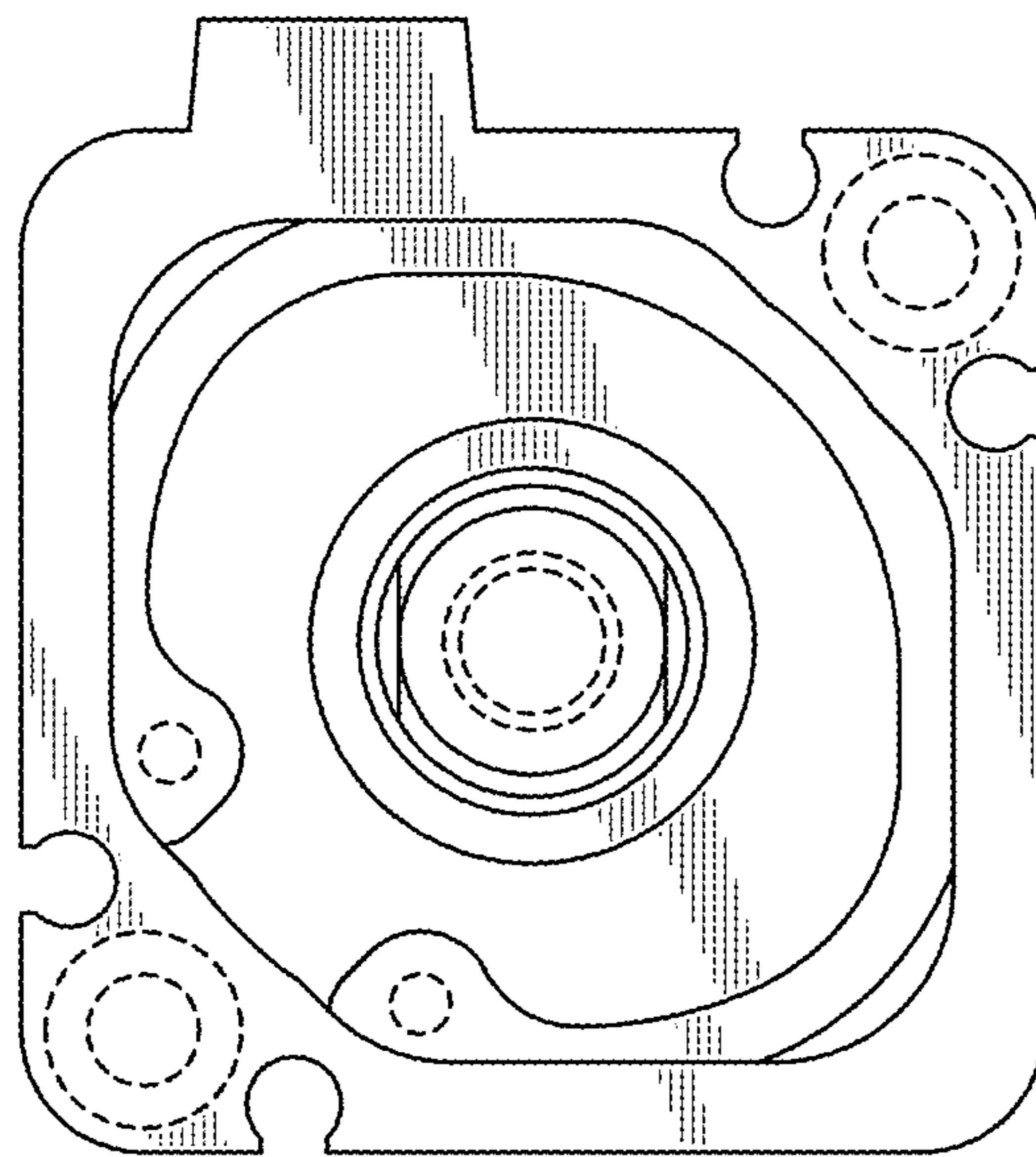

FIG. 25

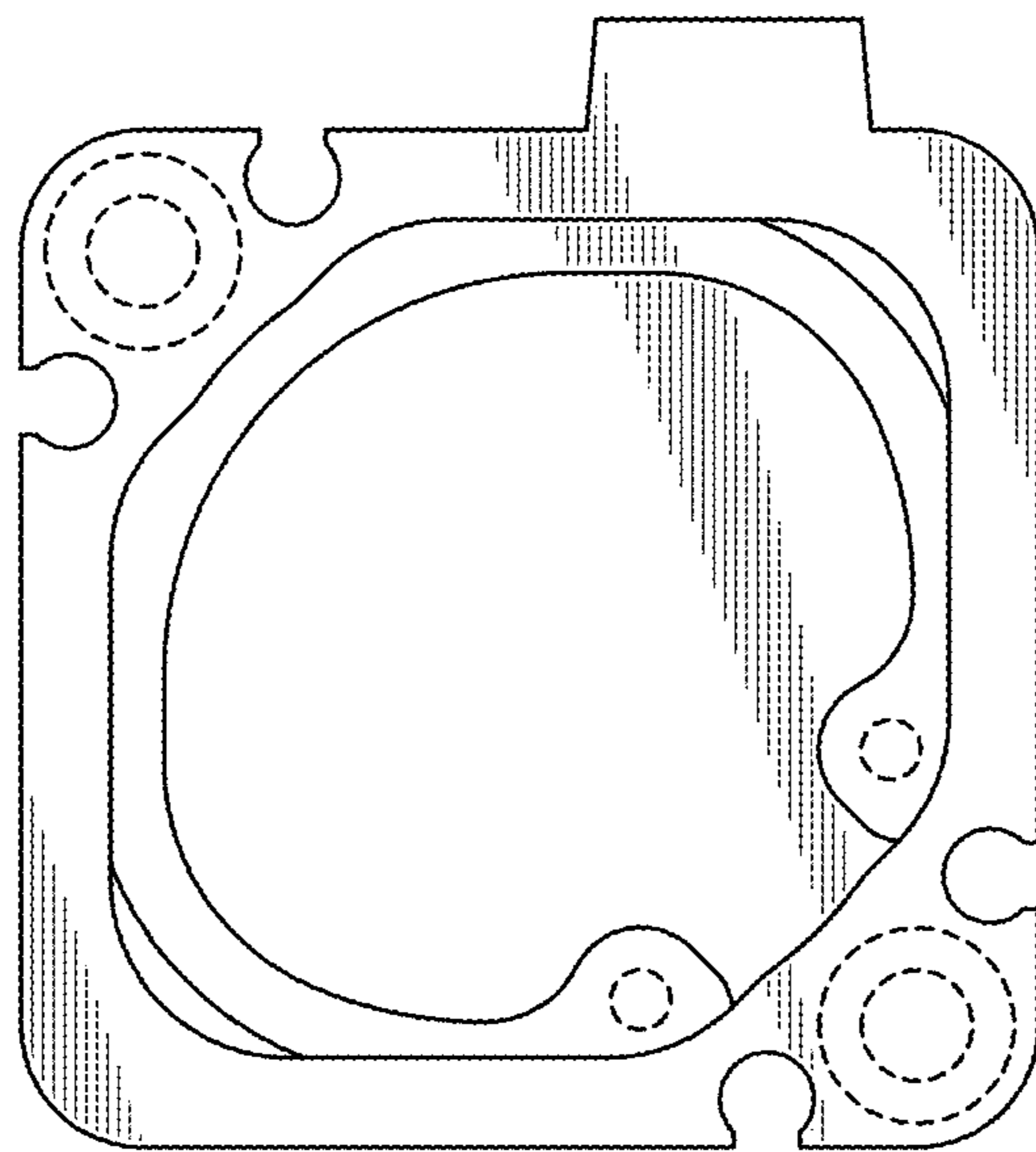

FIG. 26

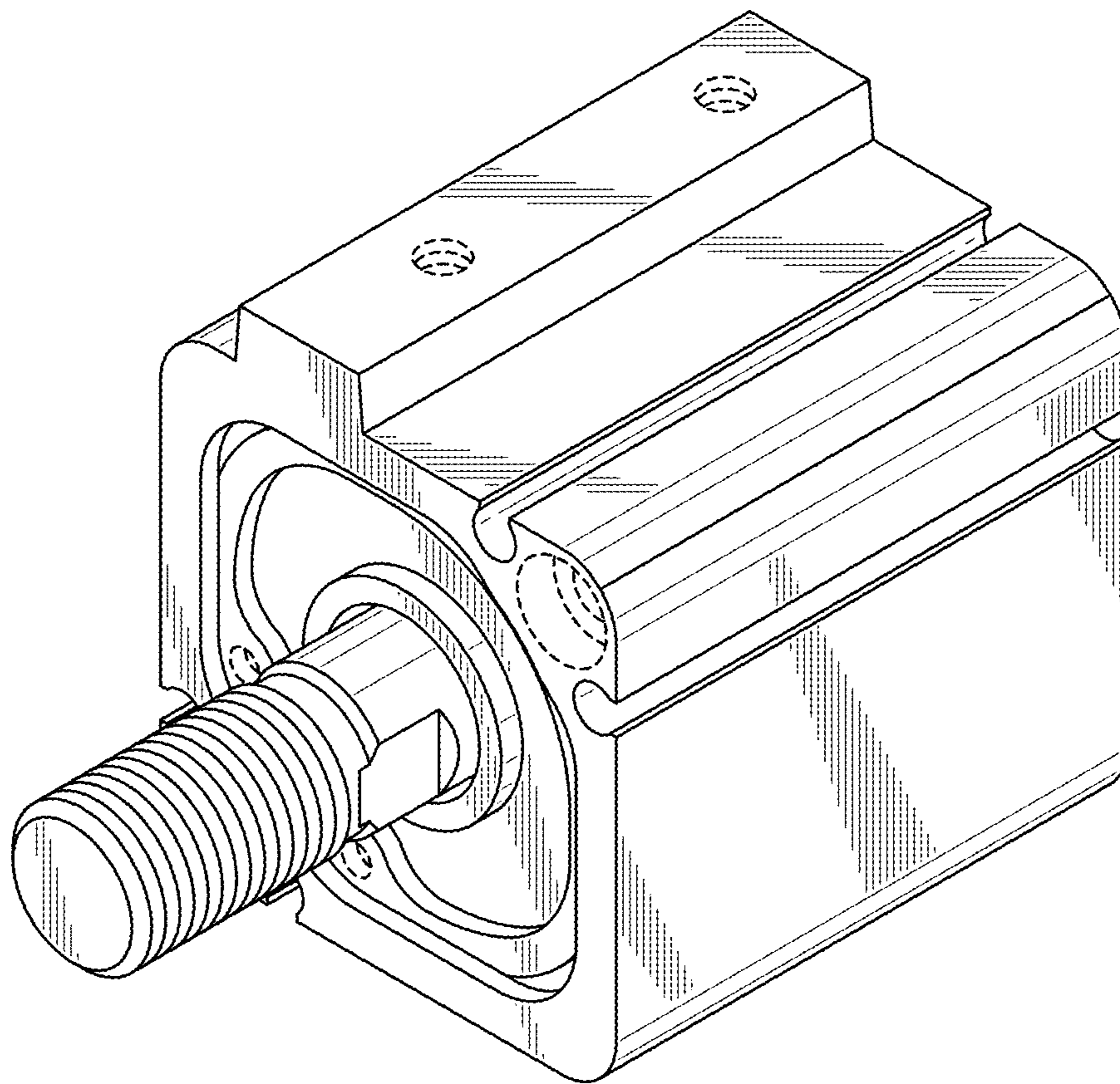

FIG. 27

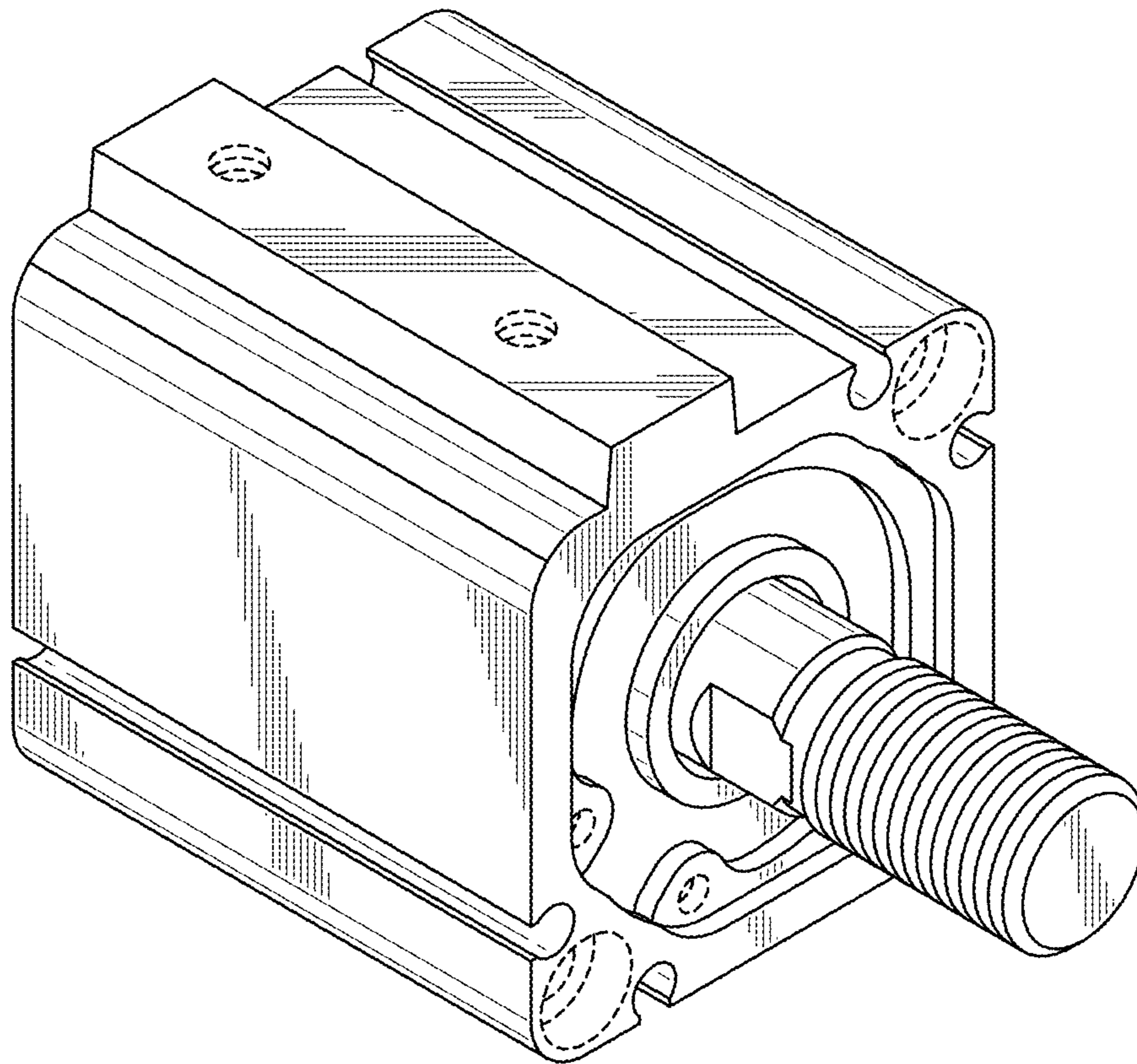

FIG. 28

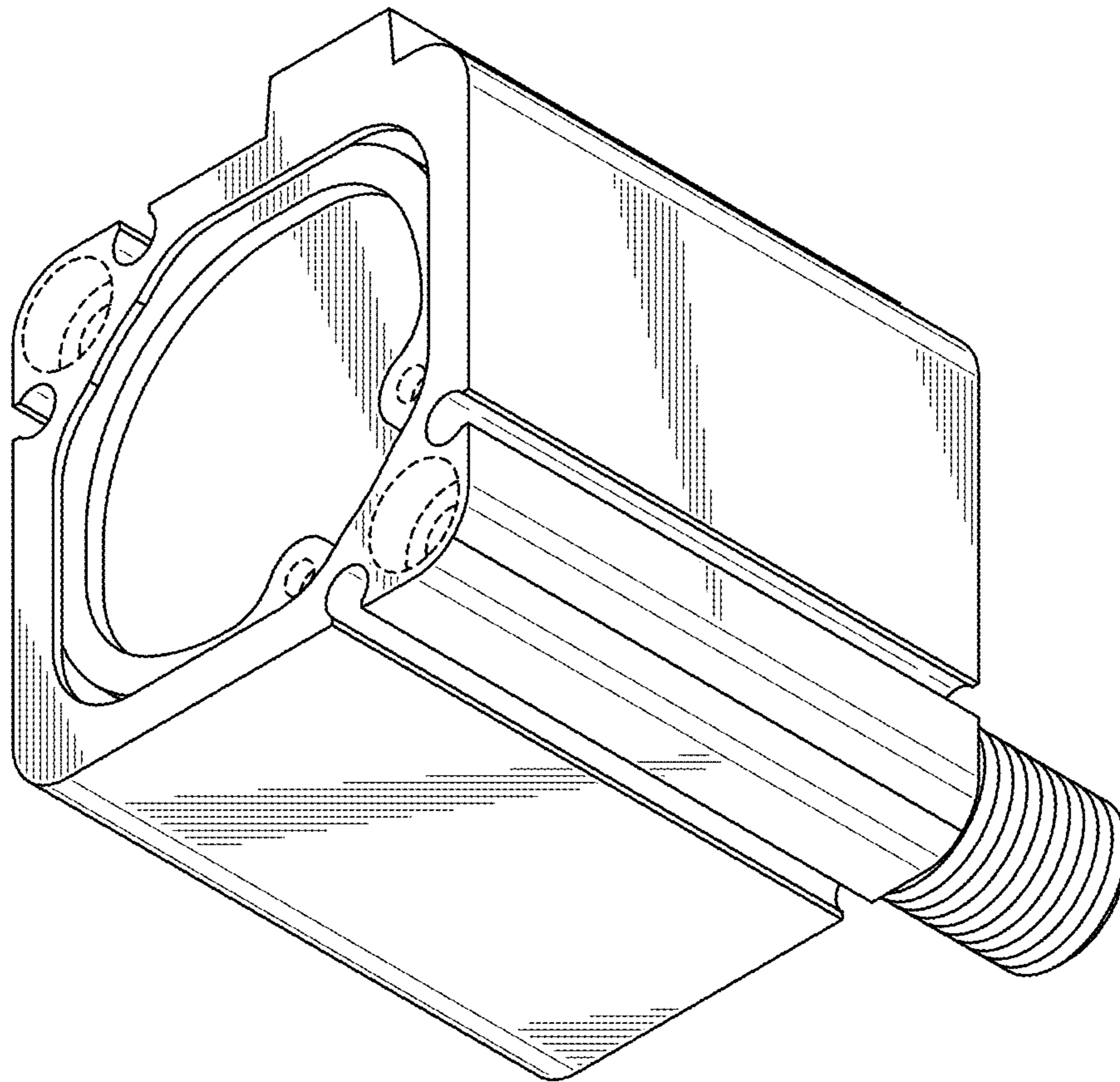

FIG. 29

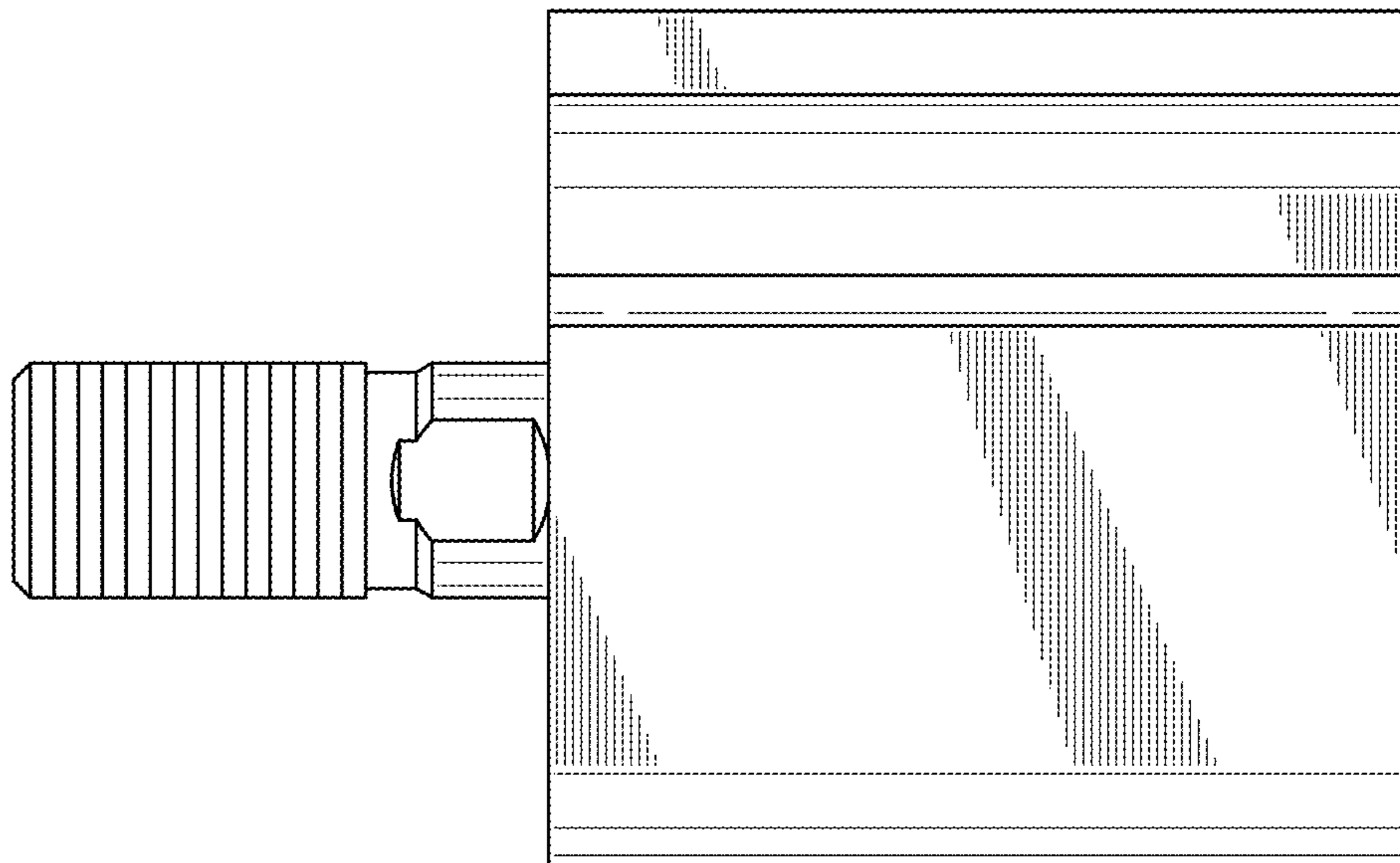

FIG. 30

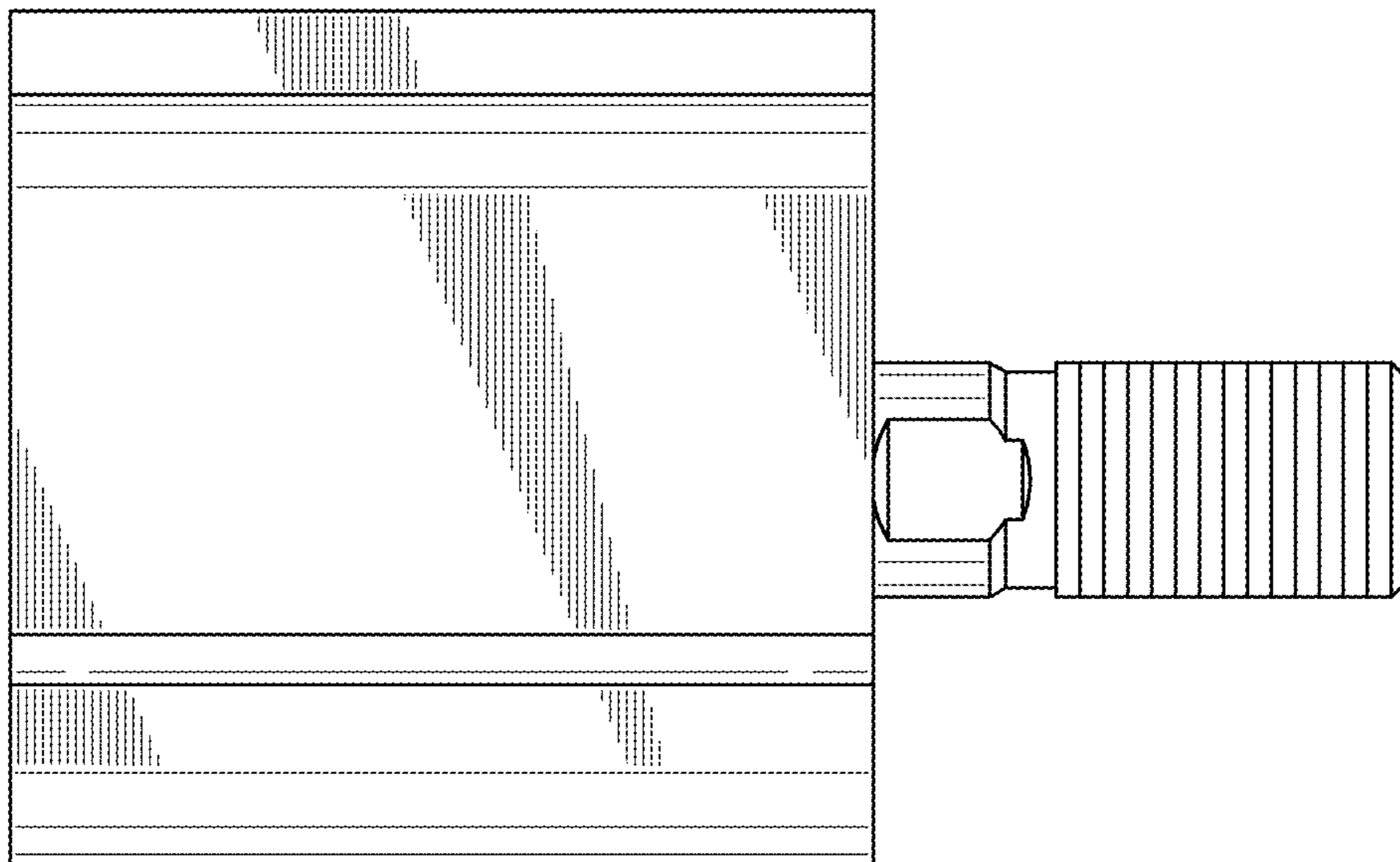



FIG. 31

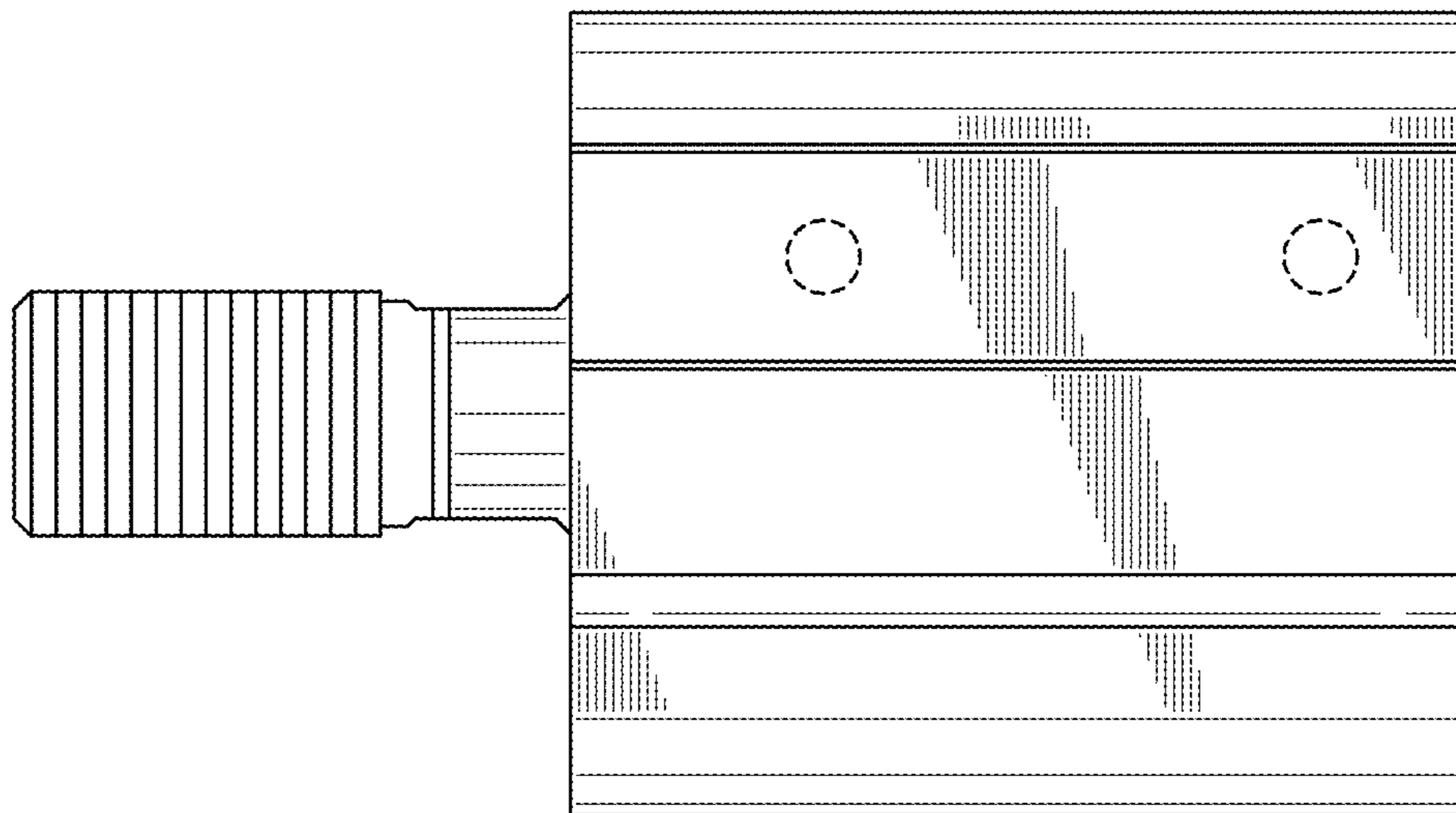

FIG. 32

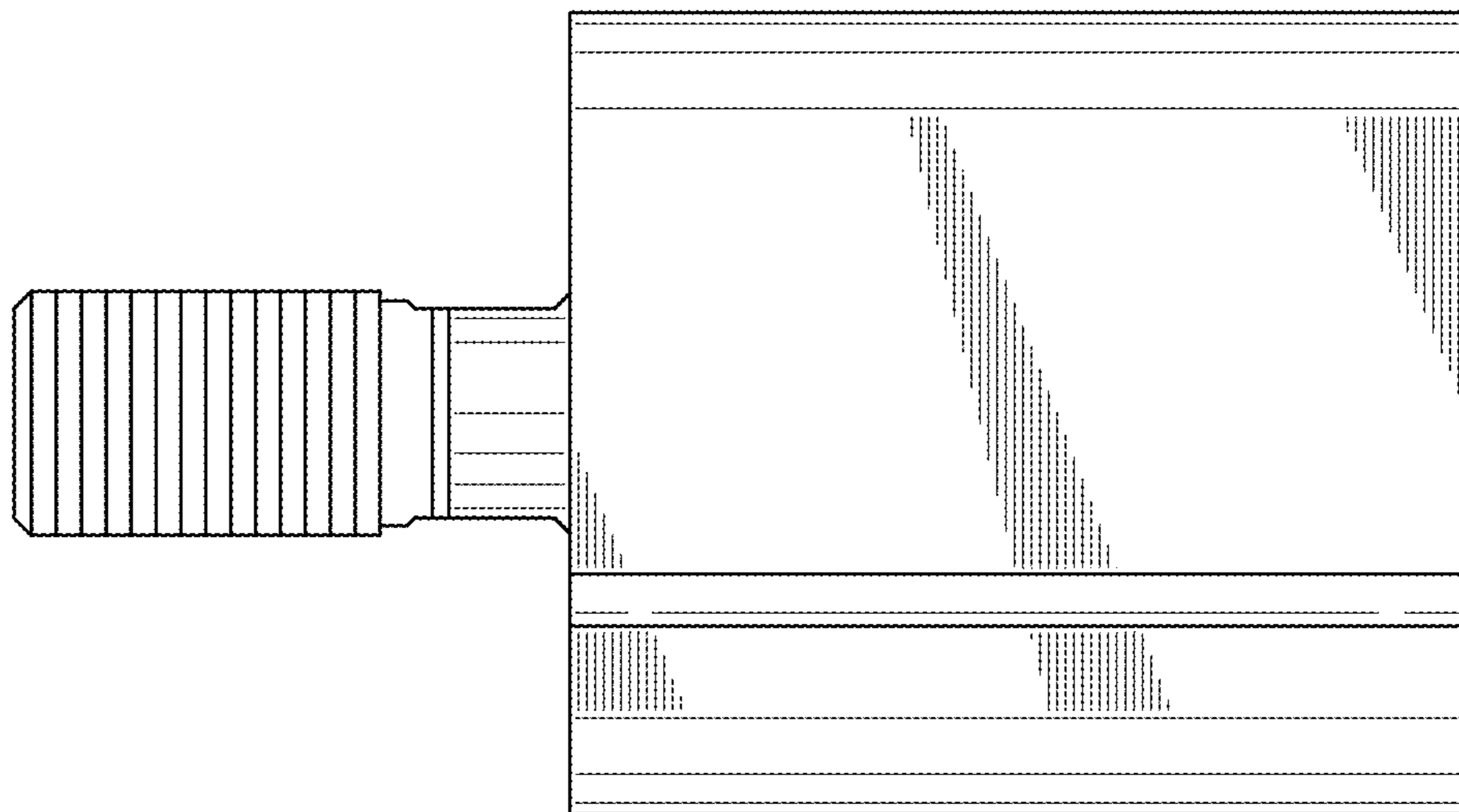

FIG. 33

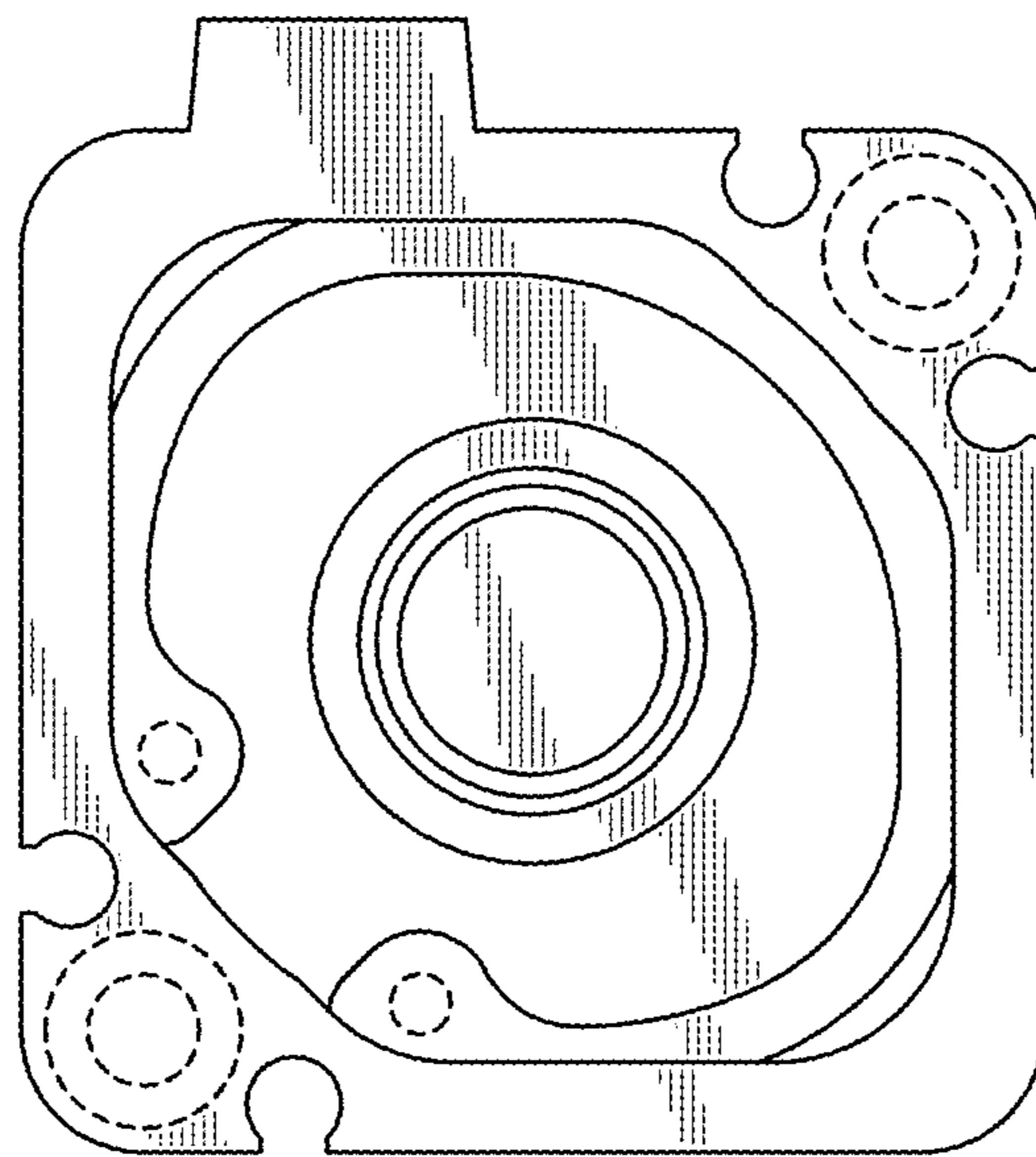

FIG. 34

