



US00D908770S

(12) **United States Design Patent**
Grant et al.

(10) **Patent No.:** **US D908,770 S**

(45) **Date of Patent:** **** *Jan. 26, 2021**

(54) **DASH CAM**

(71) Applicant: **Portable Multimedia Limited**, West End (GB)

(72) Inventors: **Robert Grant**, West End (GB);
Graham Lambert, West End (GB);
Ceri Hill, West End (GB)

(73) Assignee: **PORTABLE MULTIMEDIA LIMITED**, Surrey (GB)

(*) Notice: This patent is subject to a terminal disclaimer.

(**) Term: **15 Years**

(21) Appl. No.: **29/693,301**

(22) Filed: **May 31, 2019**

(51) **LOC (13) Cl.** **16-01**

(52) **U.S. Cl.**
USPC **D16/208; D16/218**

(58) **Field of Classification Search**
USPC D16/200, 202–210, 212, 218, 219;
348/373–376; 396/448, 535, 539–541
CPC G03B 15/03; G03B 17/02; G03B 17/04;
G03B 17/56; G03B 19/04; H04N 5/2251;
H04N 5/2252; H04N 5/2253; H04N
5/2254; H04N 2101/00
See application file for complete search history.

(56) **References Cited**

U.S. PATENT DOCUMENTS

D747,386 S * 1/2016 Li D16/208
D772,966 S * 11/2016 Song D16/200

D848,508 S * 5/2019 Hsu D16/218
D849,084 S * 5/2019 Hu D16/202
D849,817 S * 5/2019 Wang D16/218
D852,255 S * 6/2019 Guo D16/202
D854,597 S * 7/2019 Gao D16/202
D857,076 S * 8/2019 Gan D16/202
D867,420 S * 11/2019 Zhang D16/202
D868,725 S * 12/2019 Zhou D14/167
D870,183 S * 12/2019 Tsukamoto D16/218
D875,803 S * 2/2020 Yuan D16/202
2013/0004152 A1 * 1/2013 Imafuji G03B 15/02
396/155

* cited by examiner

Primary Examiner — Ramzi S Almatrahi

(74) *Attorney, Agent, or Firm* — Hickman Palermo
Becker Bingham LLP; Malgorzata A. Kulczycka

(57) **CLAIM**

The ornamental design for a dash cam, as shown and described.

DESCRIPTION

FIG. 1 is a front elevation view of a dash cam showing our new design;
FIG. 2 is a rear elevation view thereof;
FIG. 3 is a left side elevation view thereof;
FIG. 4 is a right side elevation view thereof;
FIG. 5 is a bottom plan view thereof;
FIG. 6 is a top plan view thereof; and,
FIG. 7 is an enlarged scale front and right side perspective view thereof.

The broken lines depict portions of the dash cam in which the design is embodied that form no part of the claimed design.

1 Claim, 7 Drawing Sheets

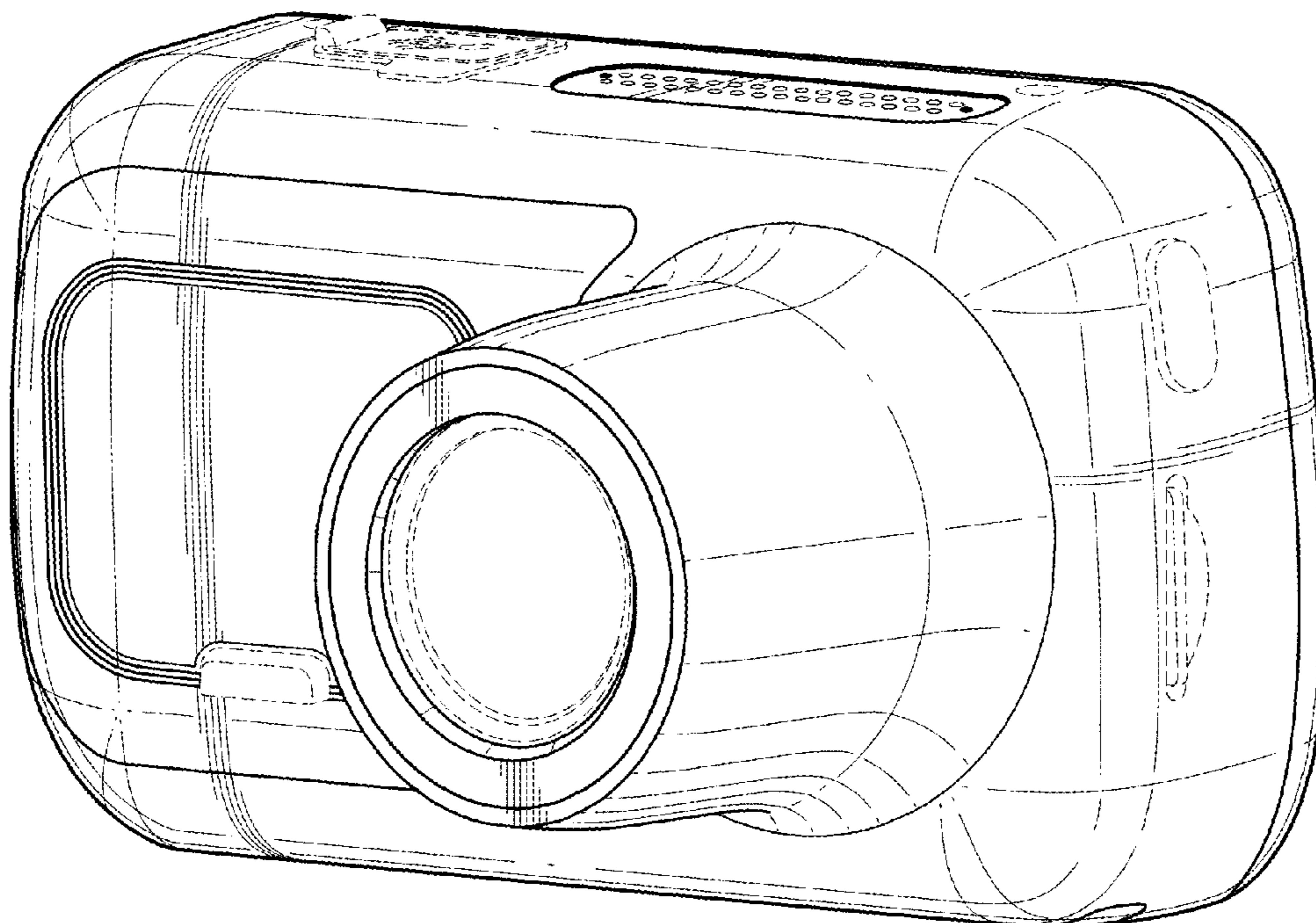

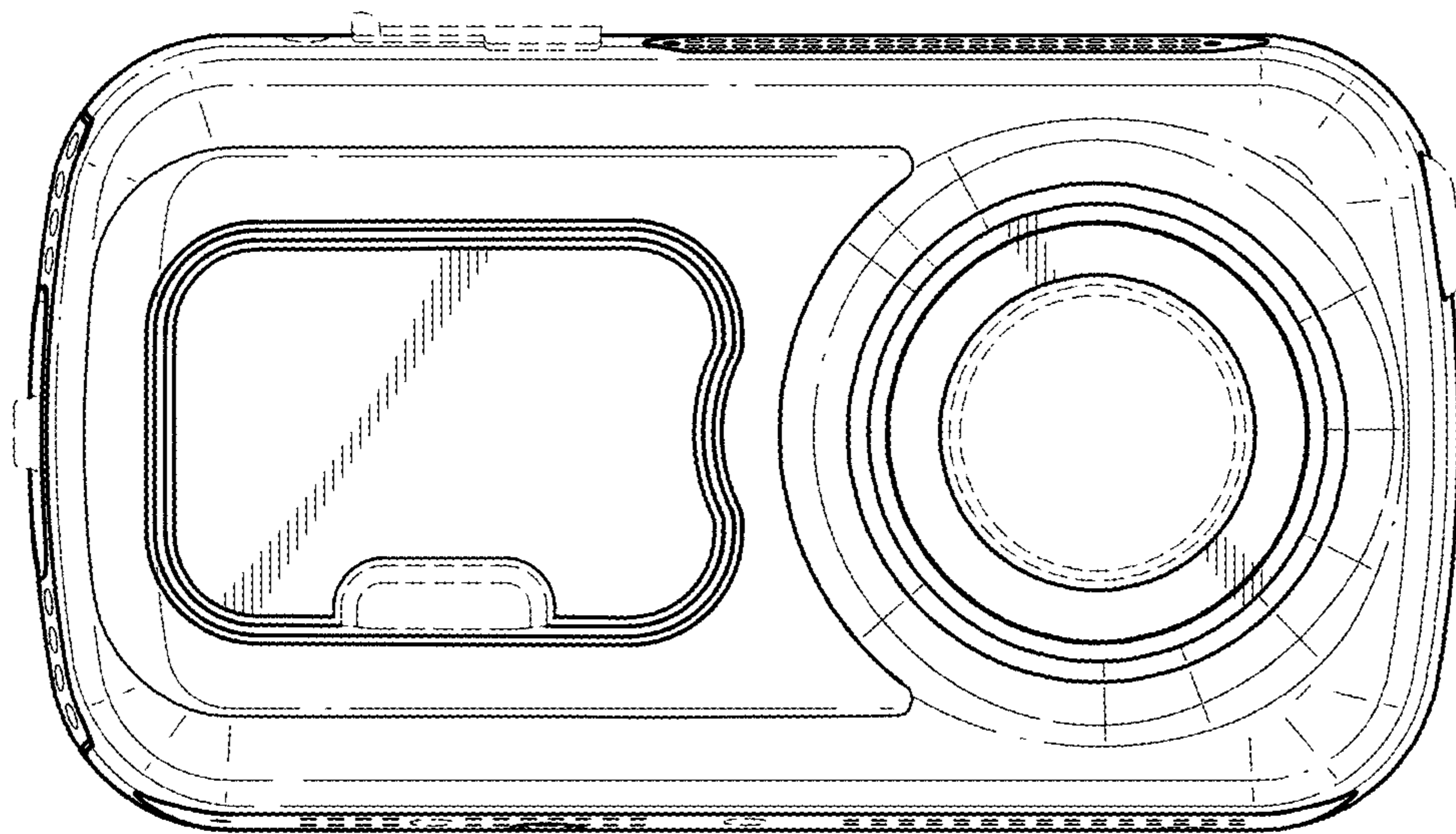

FIG. 1

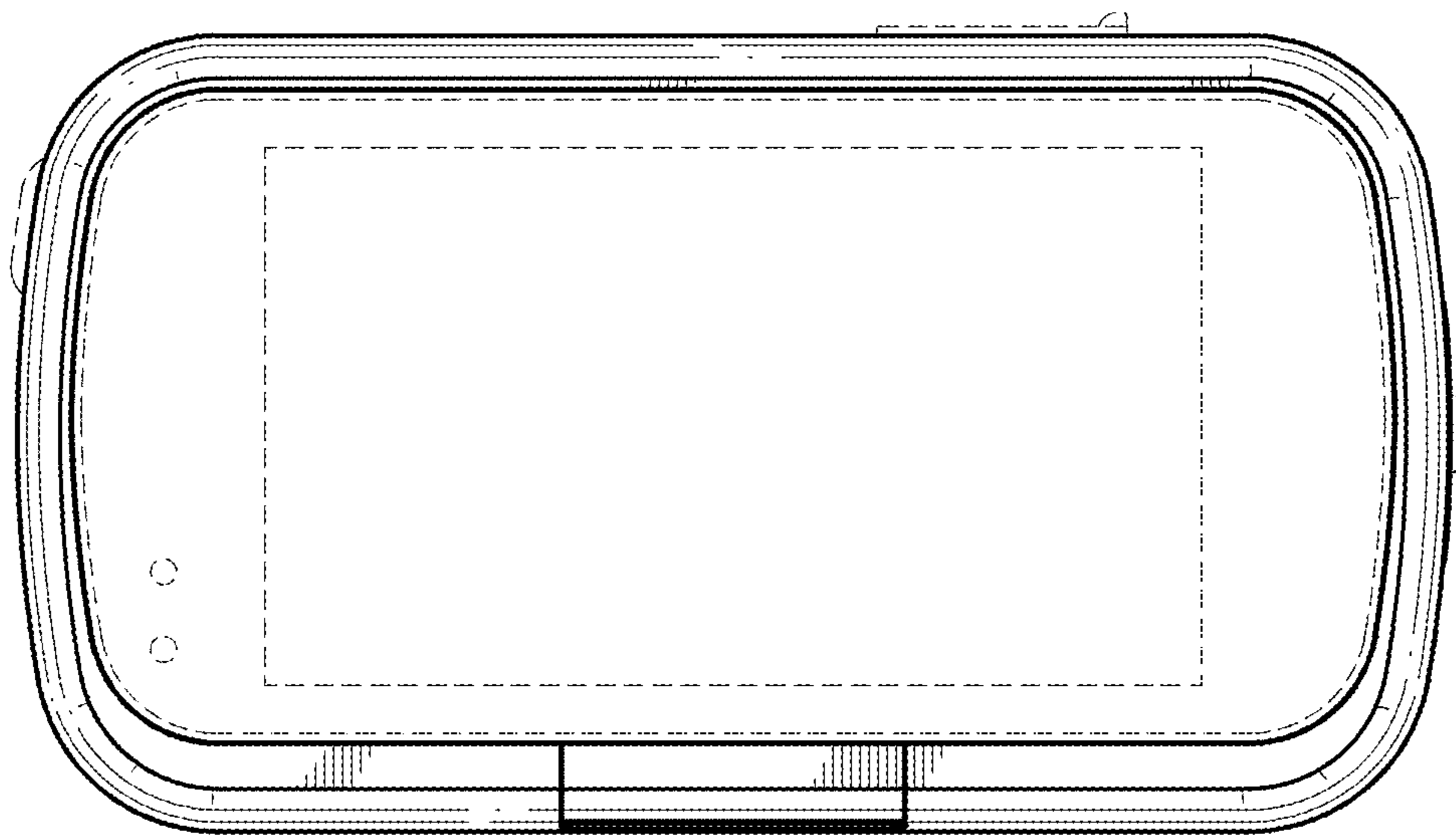

FIG. 2

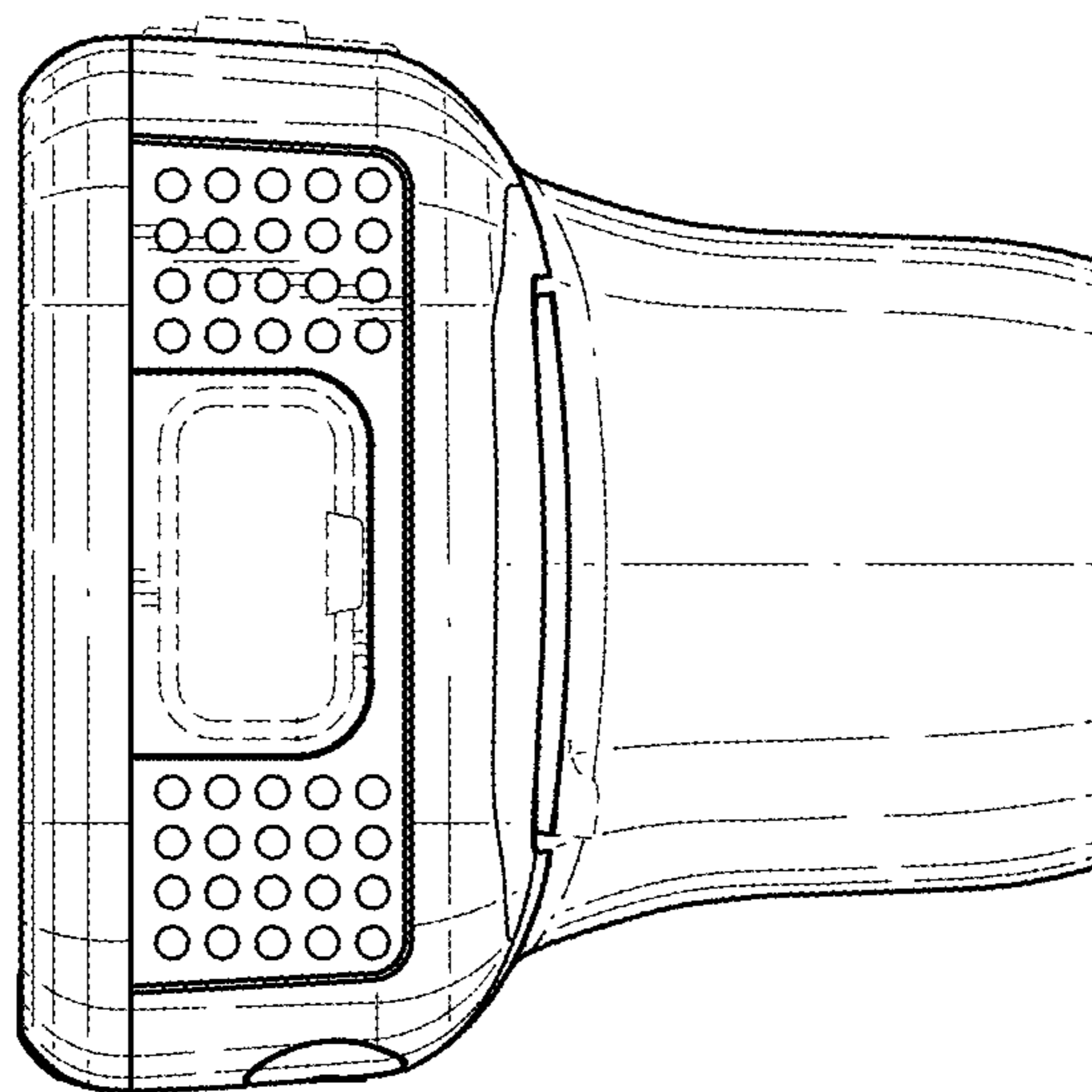

FIG. 3

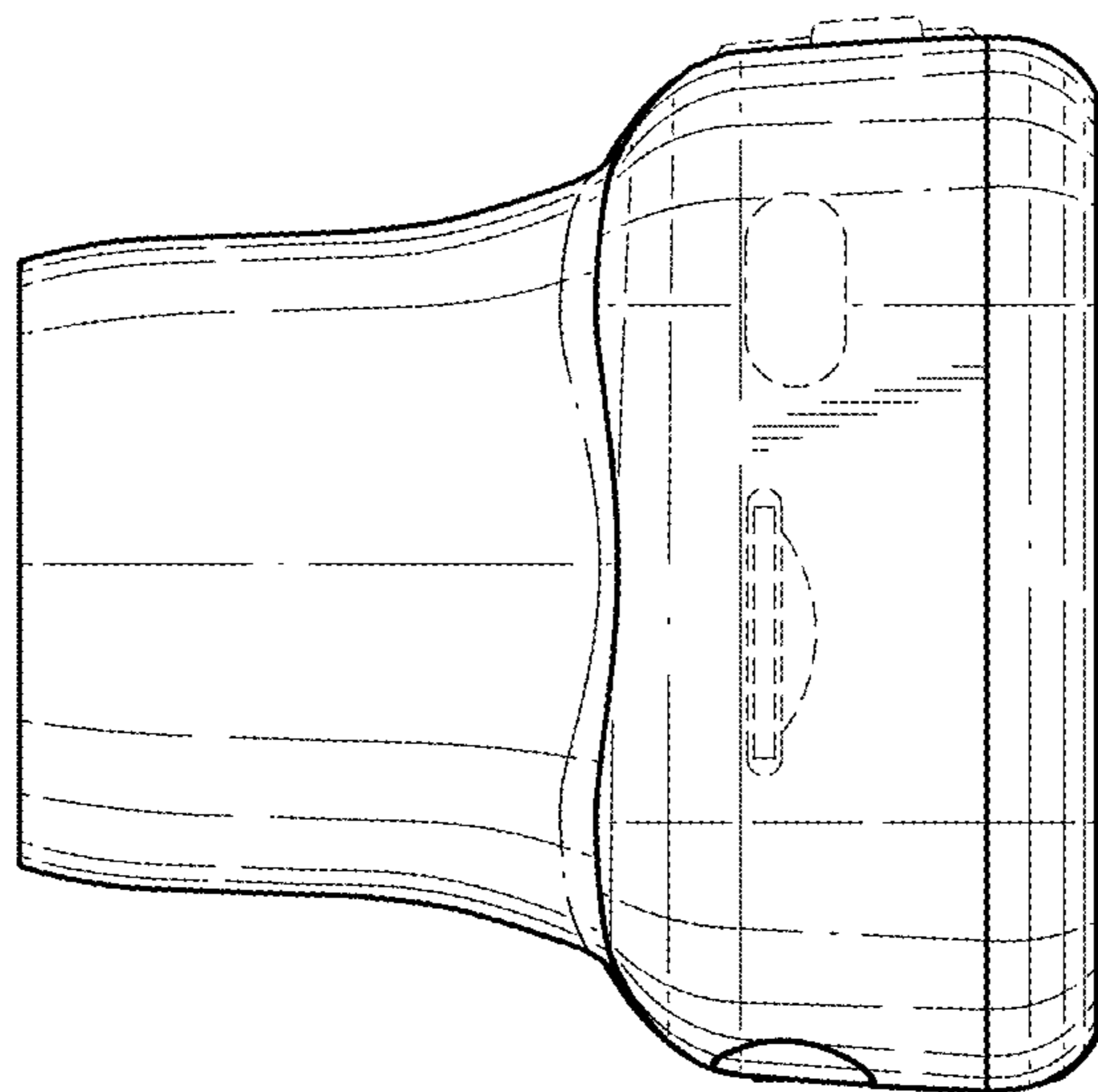

FIG. 4

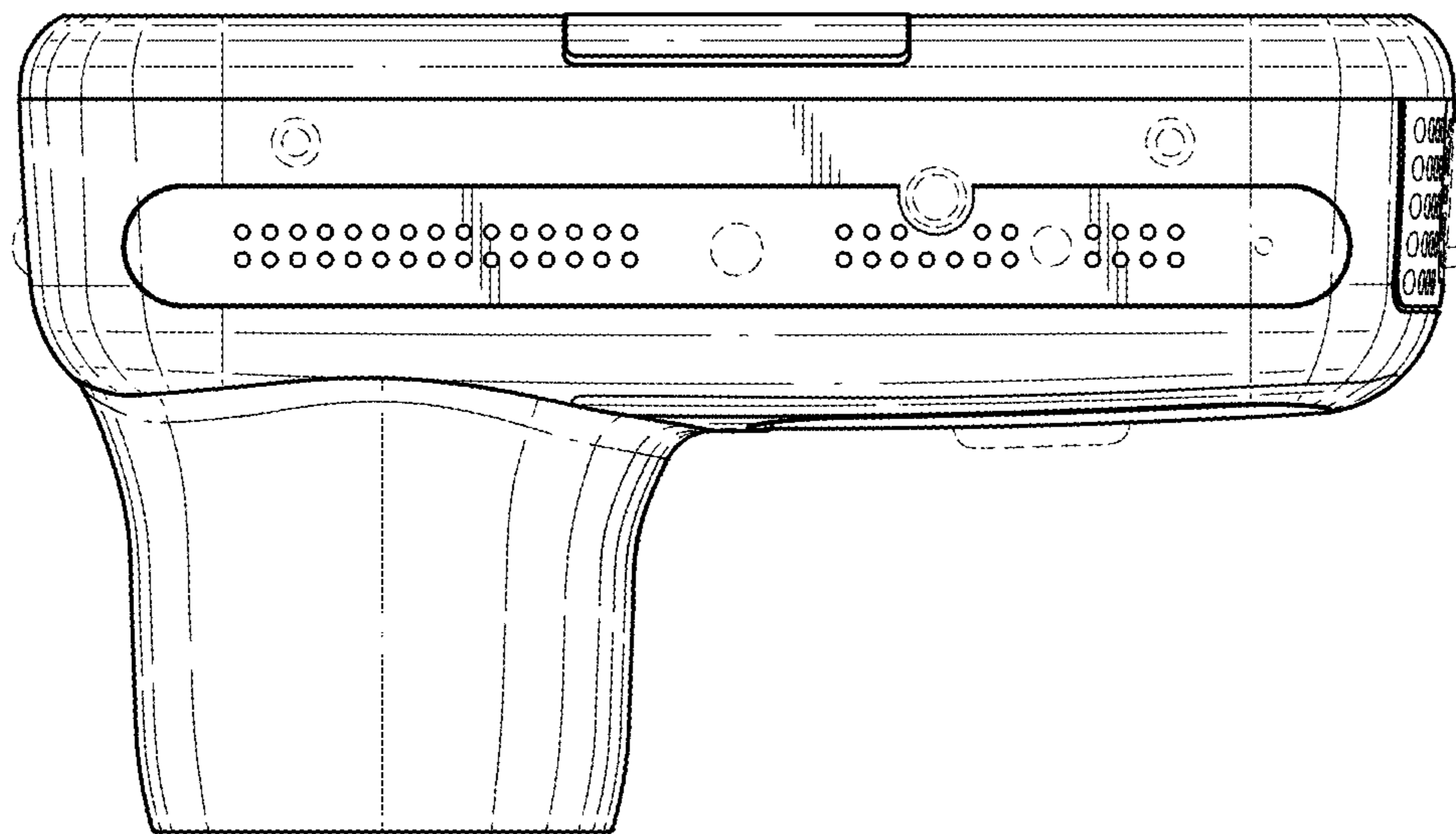

FIG. 5

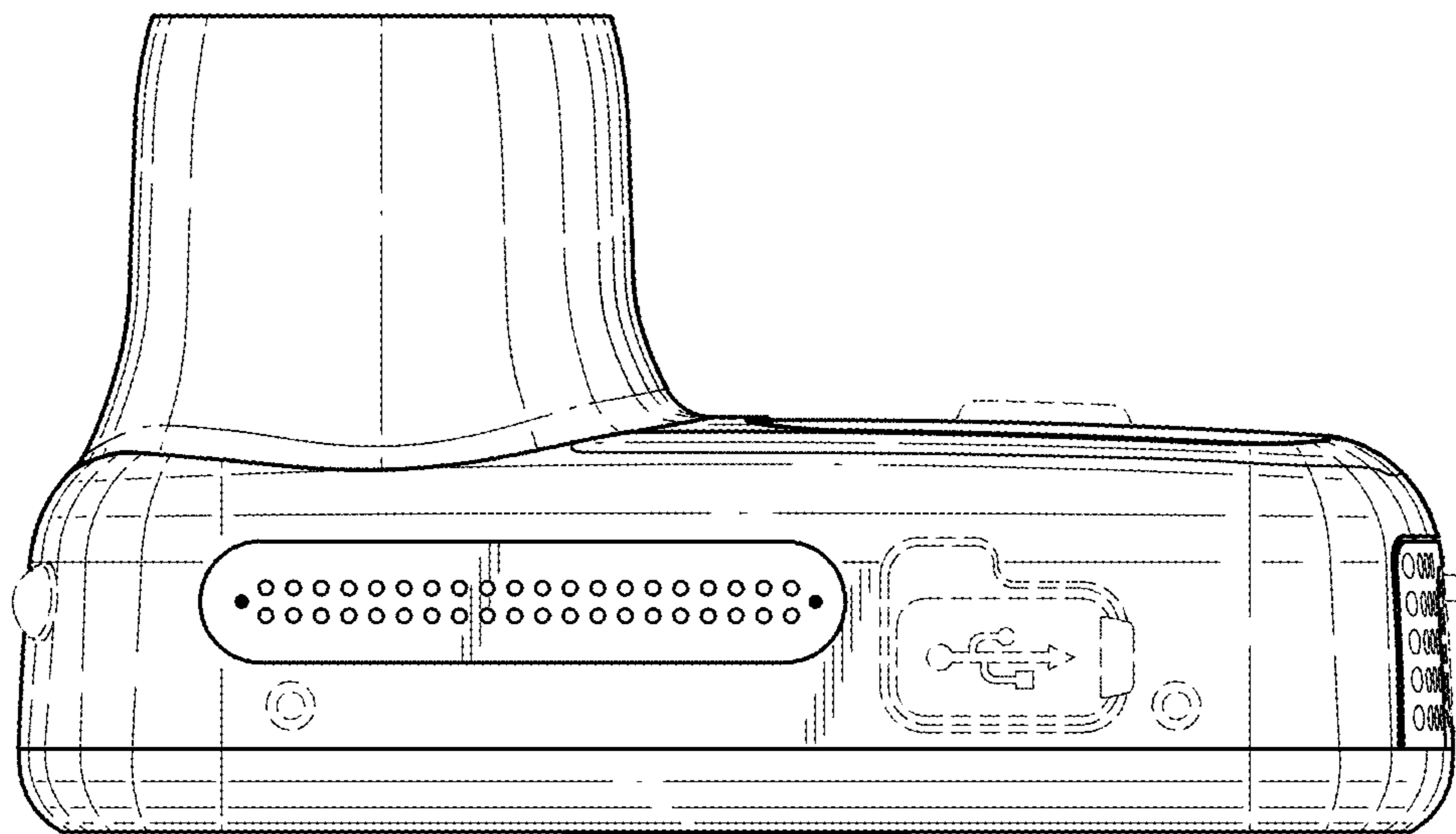

FIG. 6

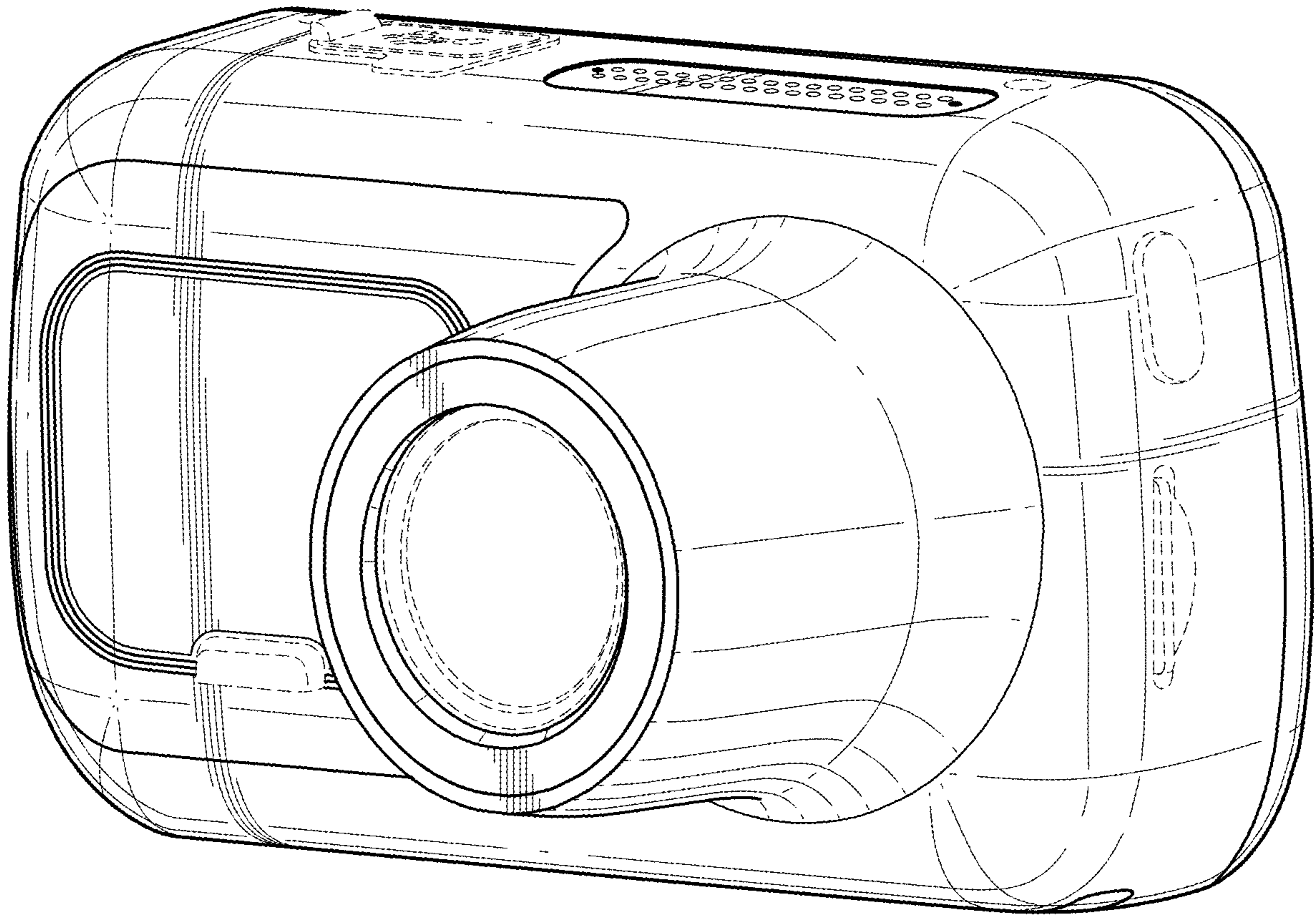

FIG. 7