



US00D908561S

(12) **United States Design Patent** (10) **Patent No.:** **US D908,561 S**
Harriton et al. (45) **Date of Patent:** **** Jan. 26, 2021**

(54) **FRONT BUMPER**

(71) Applicant: **StreetCar ORV, LLC**, Wixom, MI (US)
(72) Inventors: **David Harriton**, Missoula, MT (US); **Mark Stouffer**, Oakland Township, MI (US)
(73) Assignee: **StreetCar ORV LLC**, Wixom, MI (US)

(**) Term: **15 Years**

(21) Appl. No.: **29/668,483**

(22) Filed: **Oct. 30, 2018**

(51) **LOC (13) Cl.** **12-16**

(52) **U.S. Cl.**
USPC **D12/171**

(58) **Field of Classification Search**
USPC D12/86, 90, 91, 92, 163, 164, 169, 171, D12/196, 216
CPC B60R 19/02; B60R 19/18; B60R 19/24; B60R 19/56; B60R 2019/007; B62D 25/0845

See application file for complete search history.

(56) **References Cited**

U.S. PATENT DOCUMENTS

D300,128 S *	3/1989	Brennan	D12/169
D375,067 S *	10/1996	Bronstein	D12/169
D432,469 S *	10/2000	Nelson	D12/169
D502,433 S *	3/2005	McClanahan	D12/169
7,703,834 B1 *	4/2010	Hardy	B60R 9/06 296/102
D744,384 S *	12/2015	Harriton	D12/169
D744,387 S *	12/2015	Harriton	D12/169
D751,012 S *	3/2016	Hare	D12/169
D760,133 S *	6/2016	Bennett	D12/171
D771,537 S *	11/2016	Hare	D12/169
D775,013 S *	12/2016	Bennett	D12/169

D775,016 S *	12/2016	Reynolds	D12/171
D776,582 S *	1/2017	Bennett	D12/169
D777,619 S *	1/2017	Barajas	D12/167
D792,818 S *	7/2017	McMath	D12/169
D793,304 S *	8/2017	McMath	D12/169
D800,036 S *	10/2017	Bennett	D12/169
D826,115 S *	8/2018	Chi	D12/172
D833,922 S *	11/2018	DiCanzio	D12/163

(Continued)

Primary Examiner — Darlington Ly

(74) *Attorney, Agent, or Firm* — Quinn IP Law

(57) **CLAIM**

The ornamental design for a front bumper, as shown and described.

DESCRIPTION

FIG. 1 is a front perspective view of a front bumper showing our new design in accordance to a first embodiment that is suitable for the right side of a vehicle;
FIG. 2 is a front elevation view thereof;
FIG. 3 is a rear elevation view thereof;
FIG. 4 is a right side elevation view thereof;
FIG. 5 is a left side elevation view thereof;
FIG. 6 is a top plan view thereof;
FIG. 7 is a bottom plan view thereof; and
FIG. 8 is a rear perspective view thereof.
FIG. 9 is a front perspective view of a front bumper showing our new design in accordance to a second embodiment that is suitable for the left side of a vehicle;
FIG. 10 is a front elevation view thereof;
FIG. 11 is a rear elevation view thereof;
FIG. 12 is a right side elevation view thereof;
FIG. 13 is a left side elevation view thereof;
FIG. 14 is a top plan view thereof;
FIG. 15 is a bottom plan view thereof; and
FIG. 16 is a rear perspective view thereof.
The broken lines illustrate portions of the front bumper that form no part of the claimed design.

1 Claim, 12 Drawing Sheets

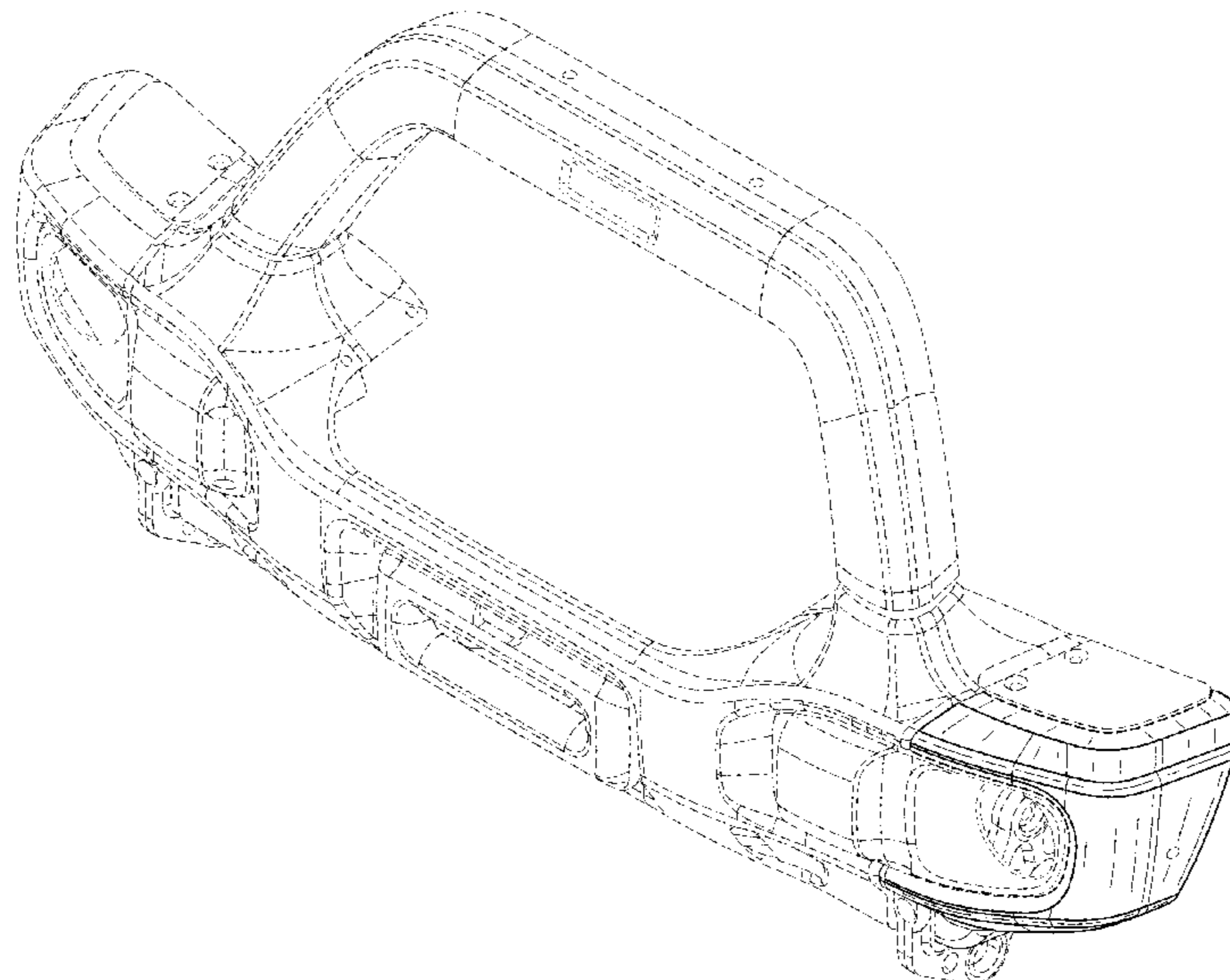

(56)

References Cited

U.S. PATENT DOCUMENTS

D847,051 S * 4/2019 DiCanzio D12/171
2017/0088076 A1 * 3/2017 Fujimoto B60R 19/04

* cited by examiner

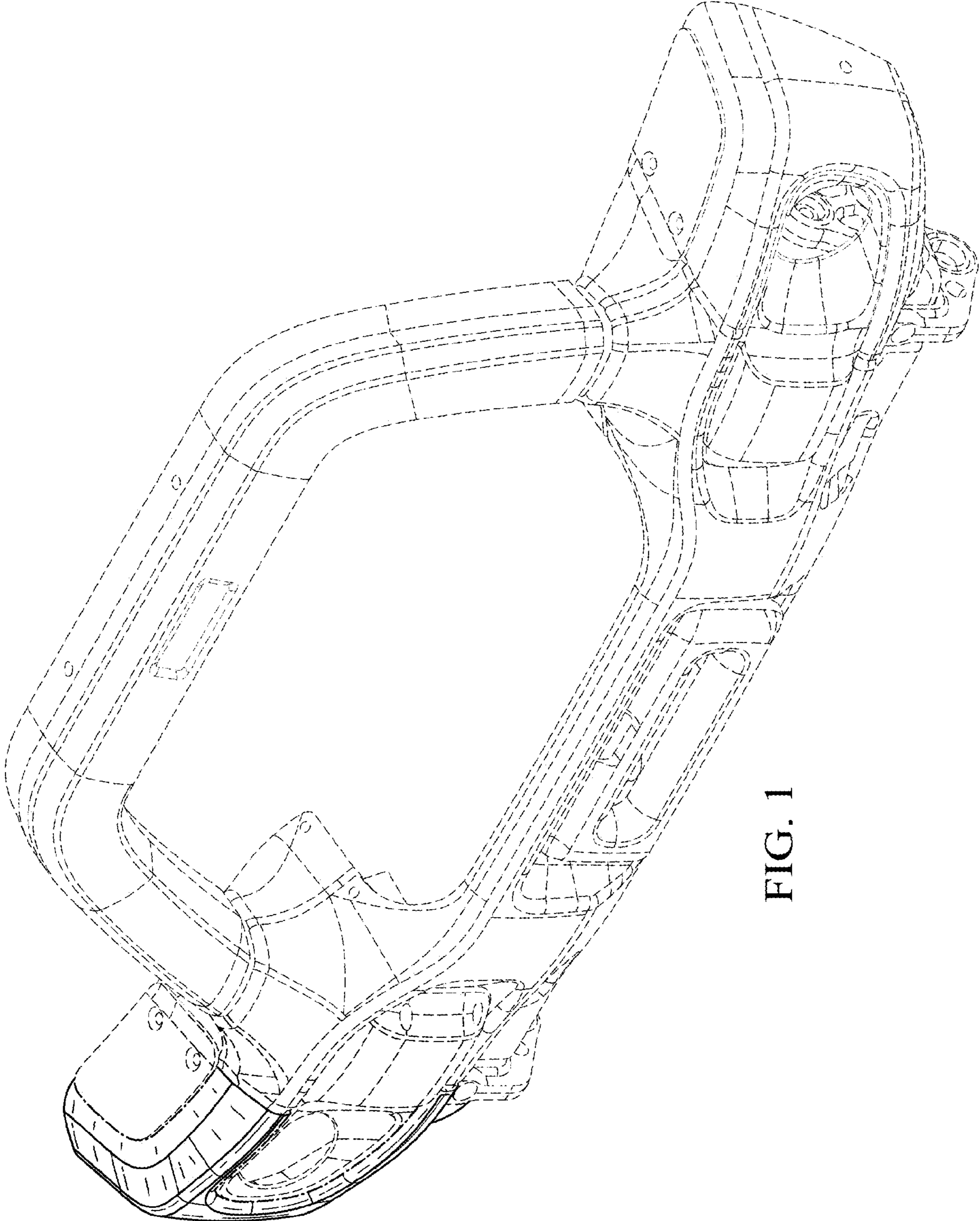

FIG. 1

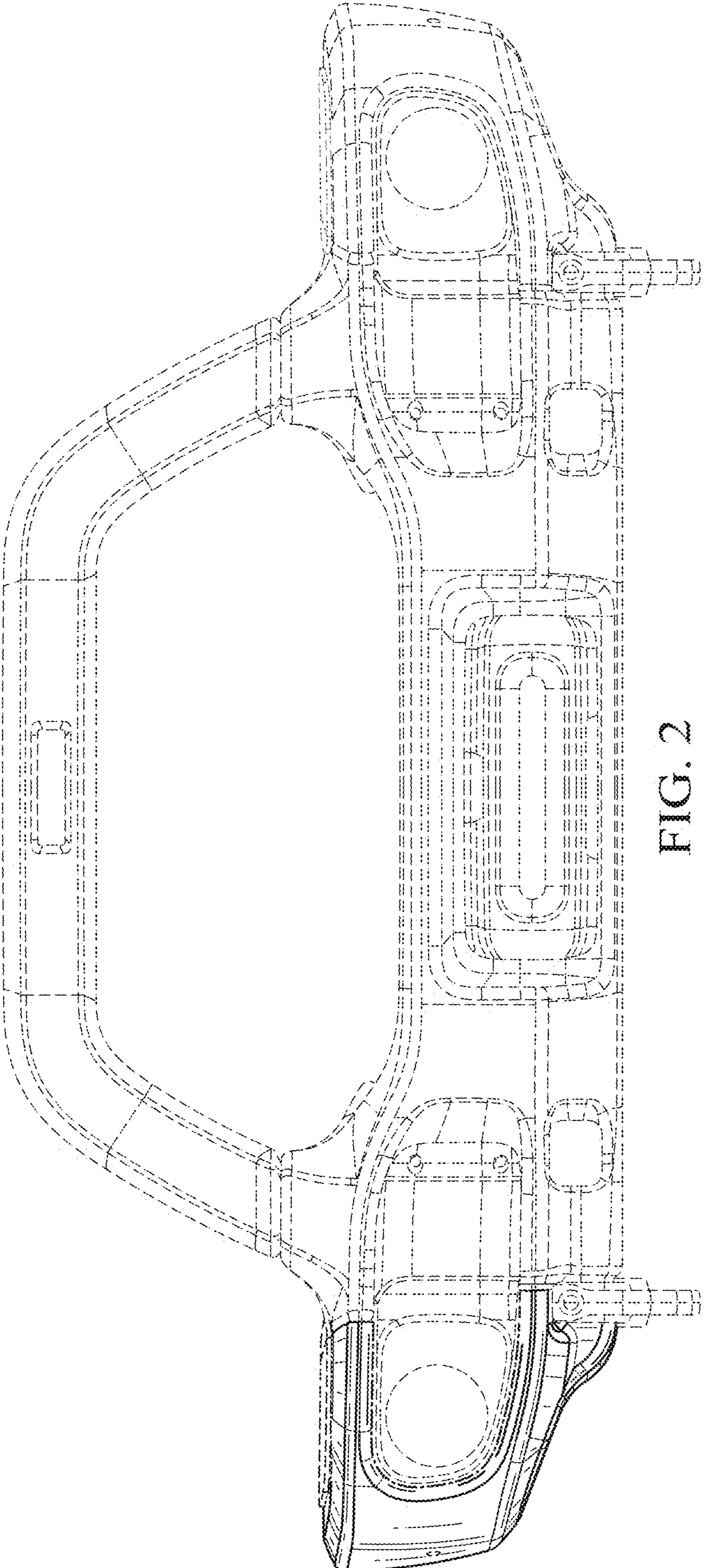

FIG. 2

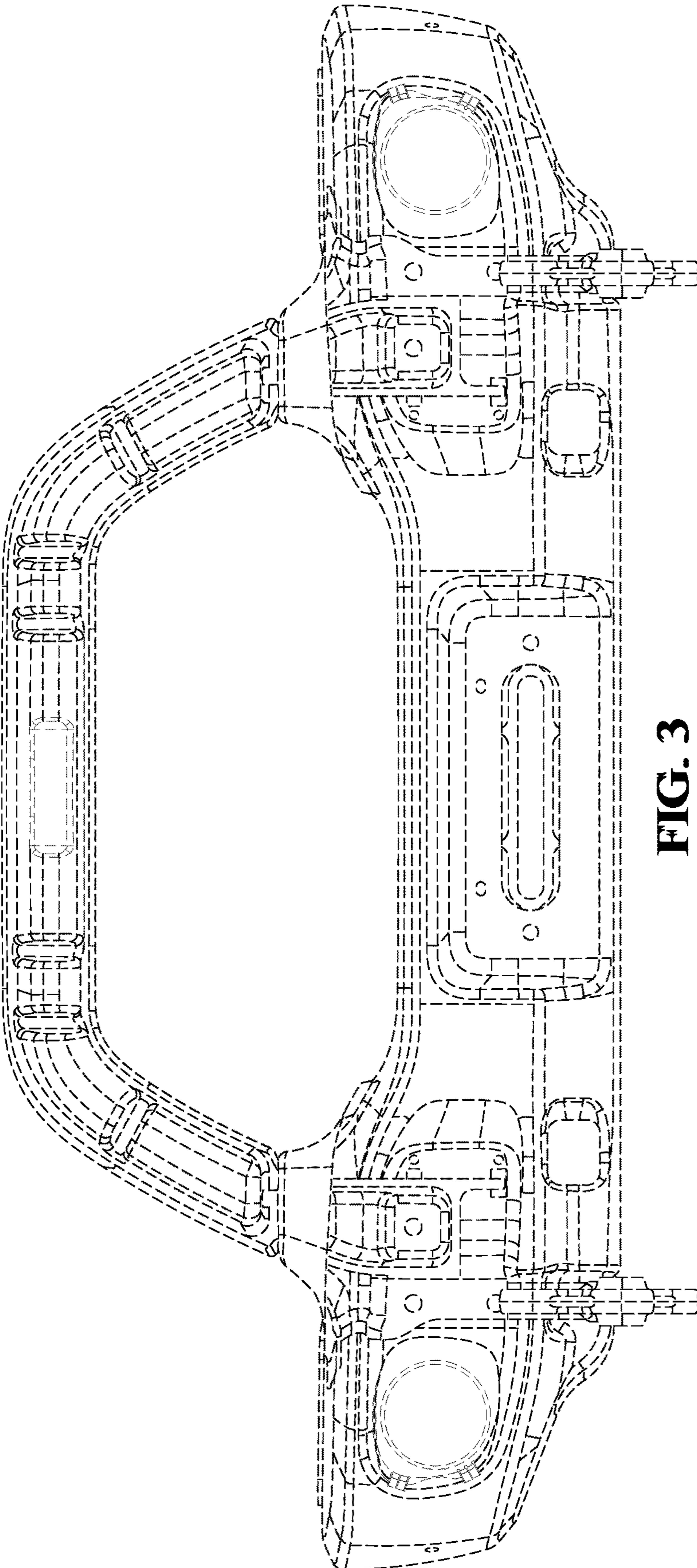

FIG. 3

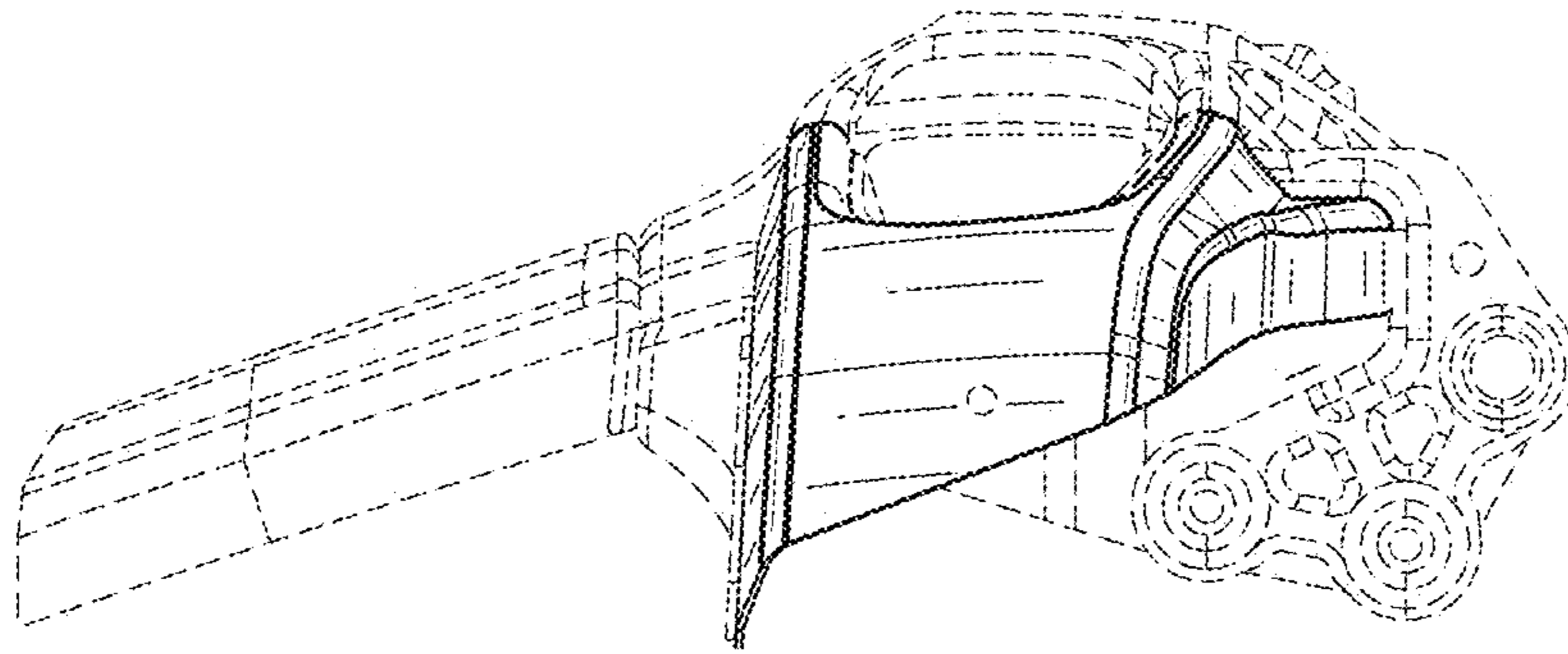

FIG. 5

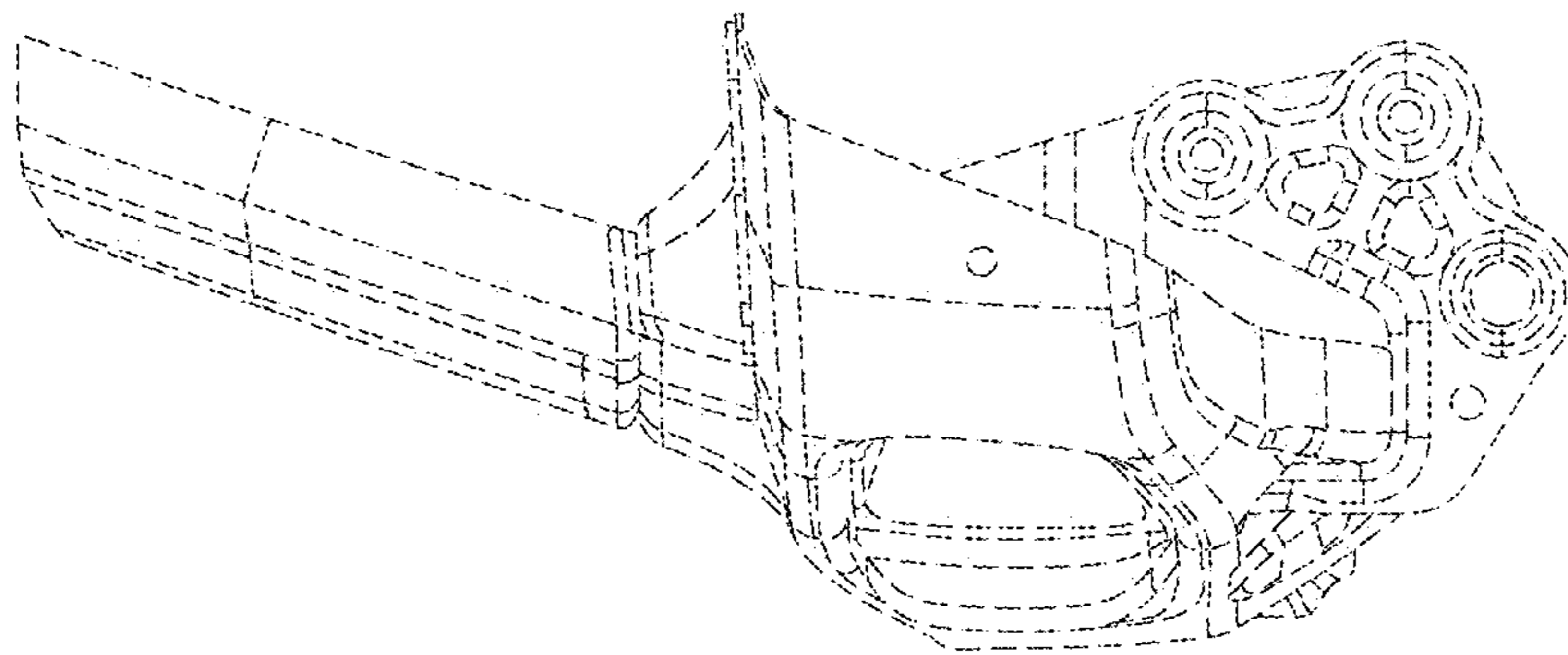

FIG. 4



FIG. 6

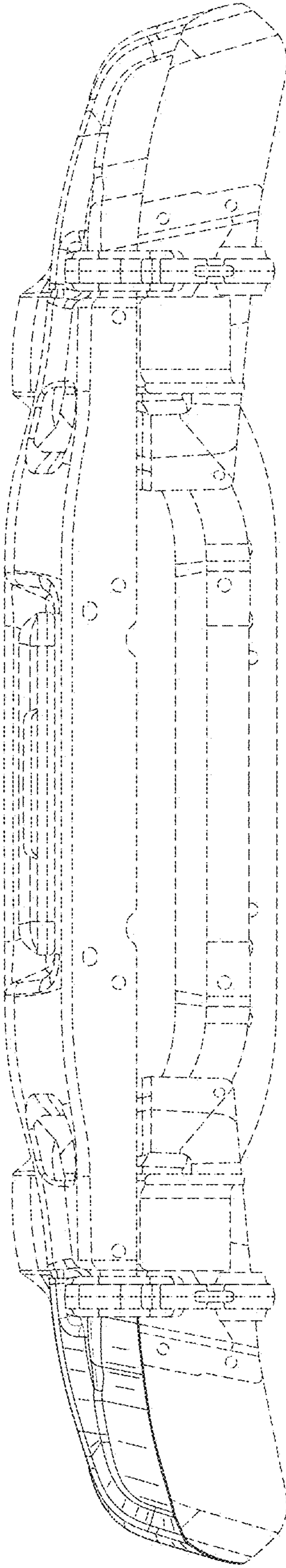

FIG. 7

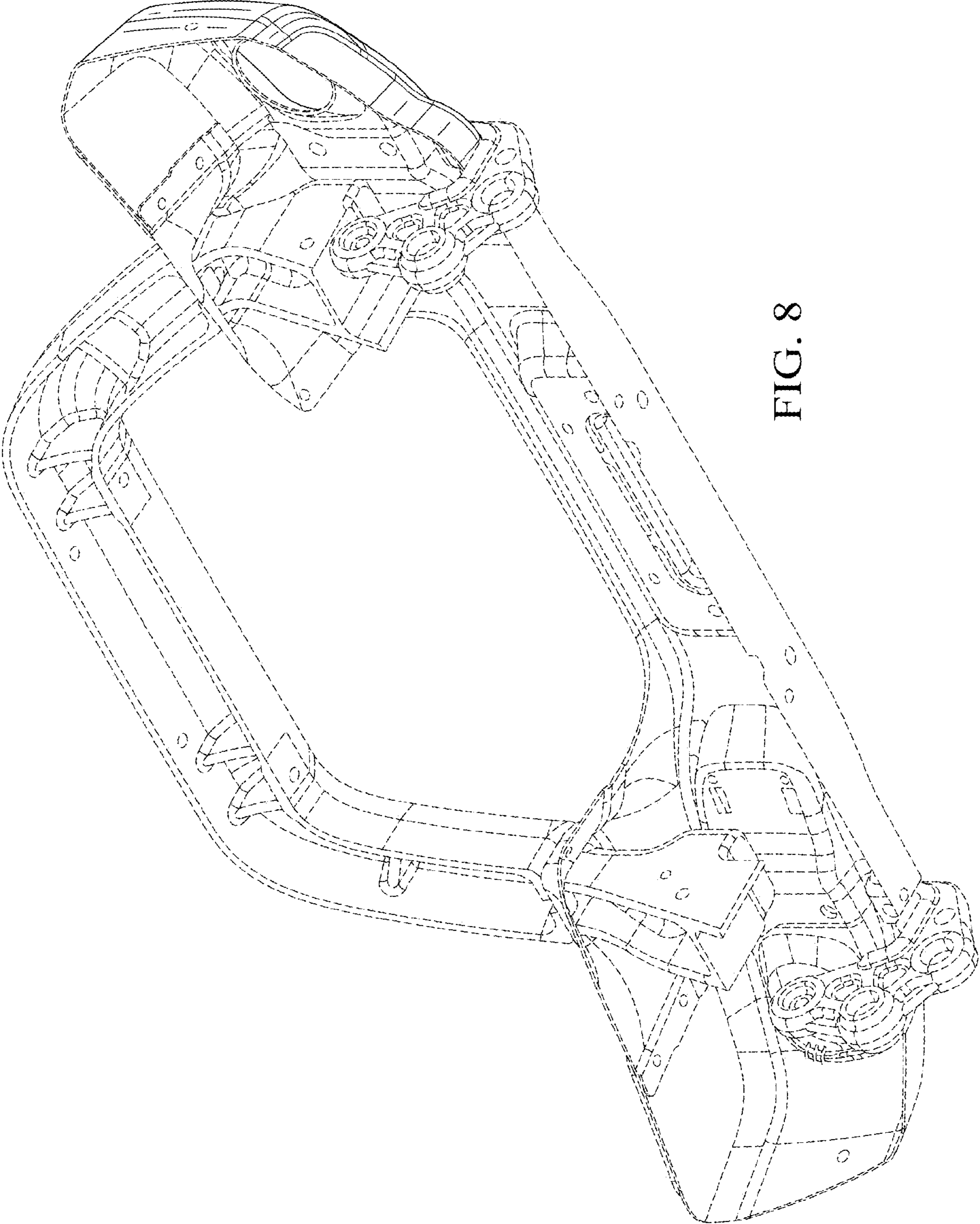

FIG. 8

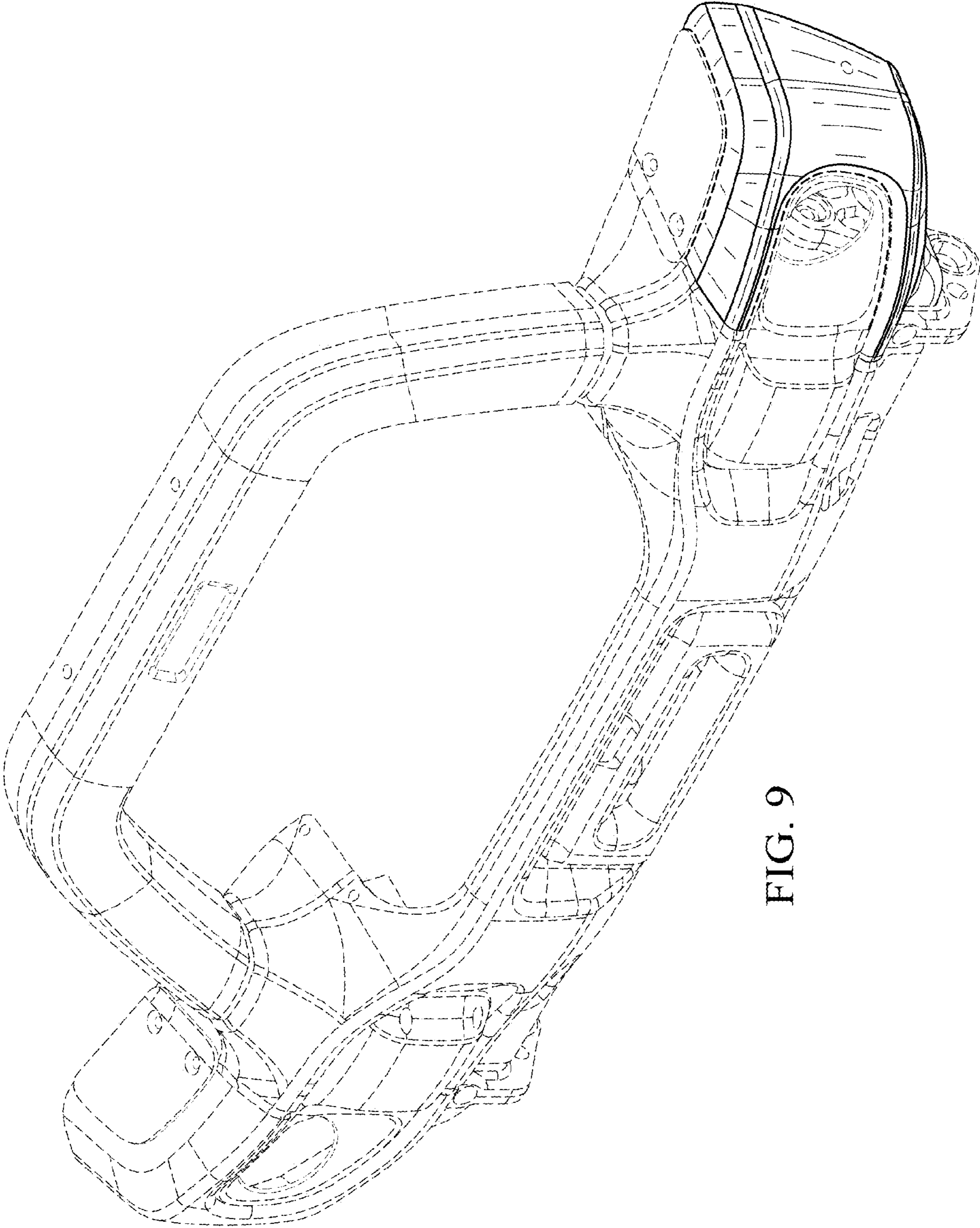

FIG. 9

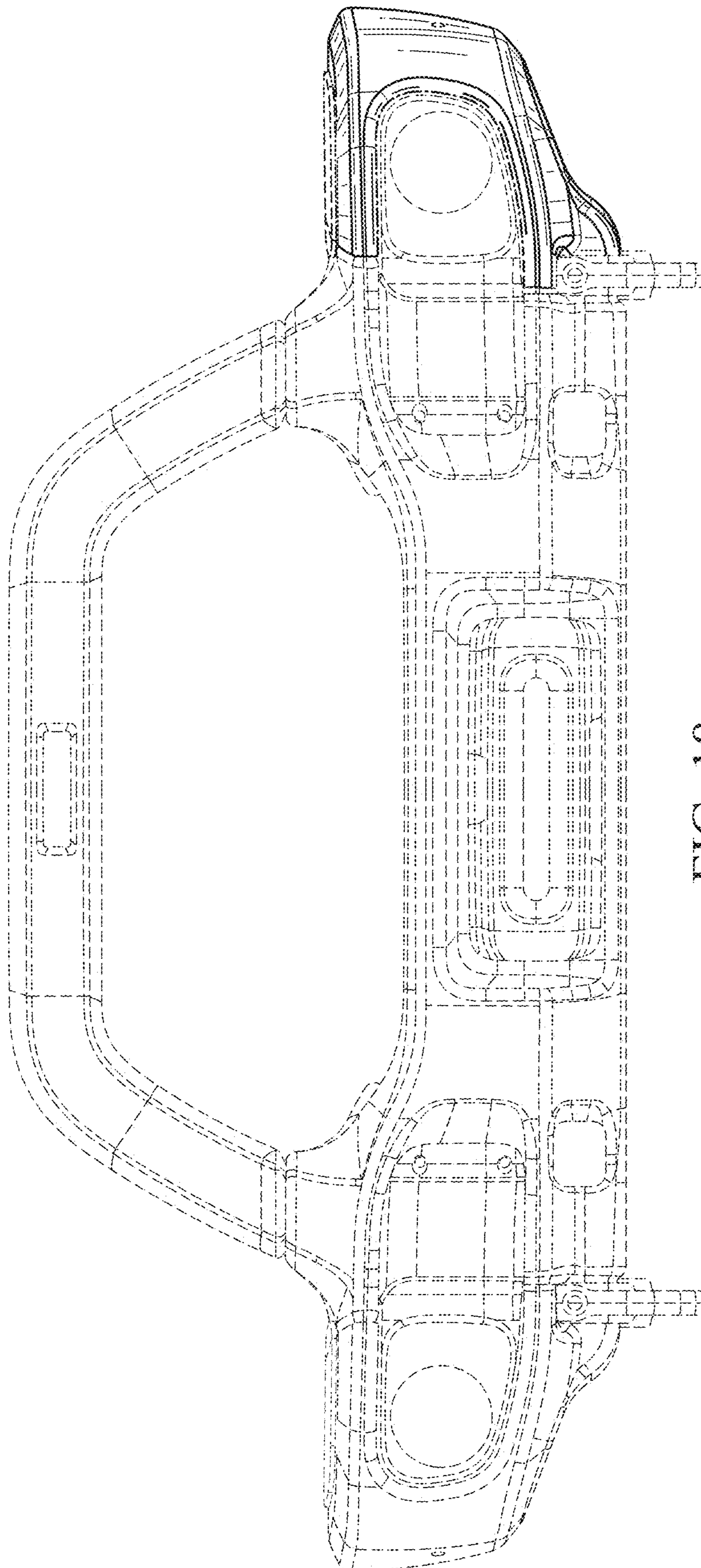

FIG. 10

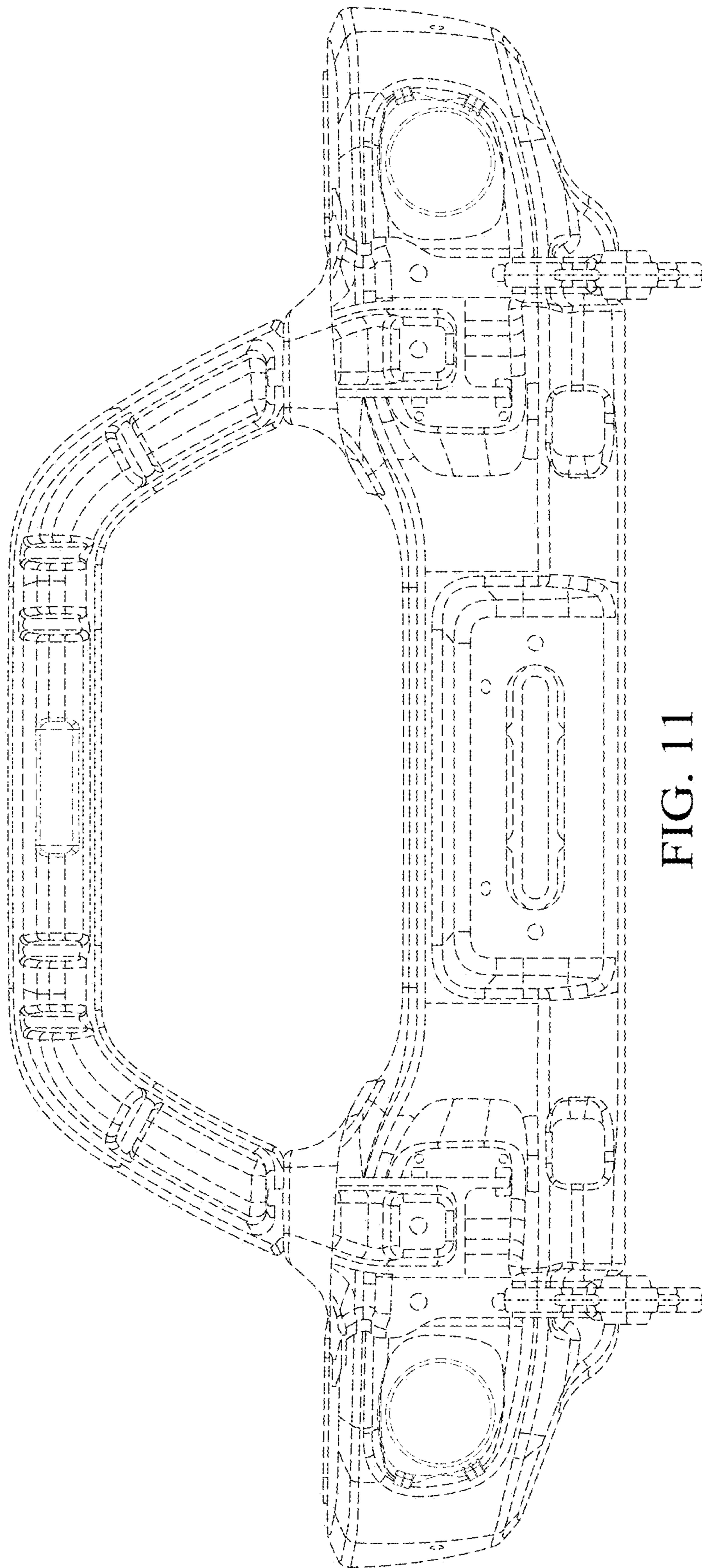

FIG. 11

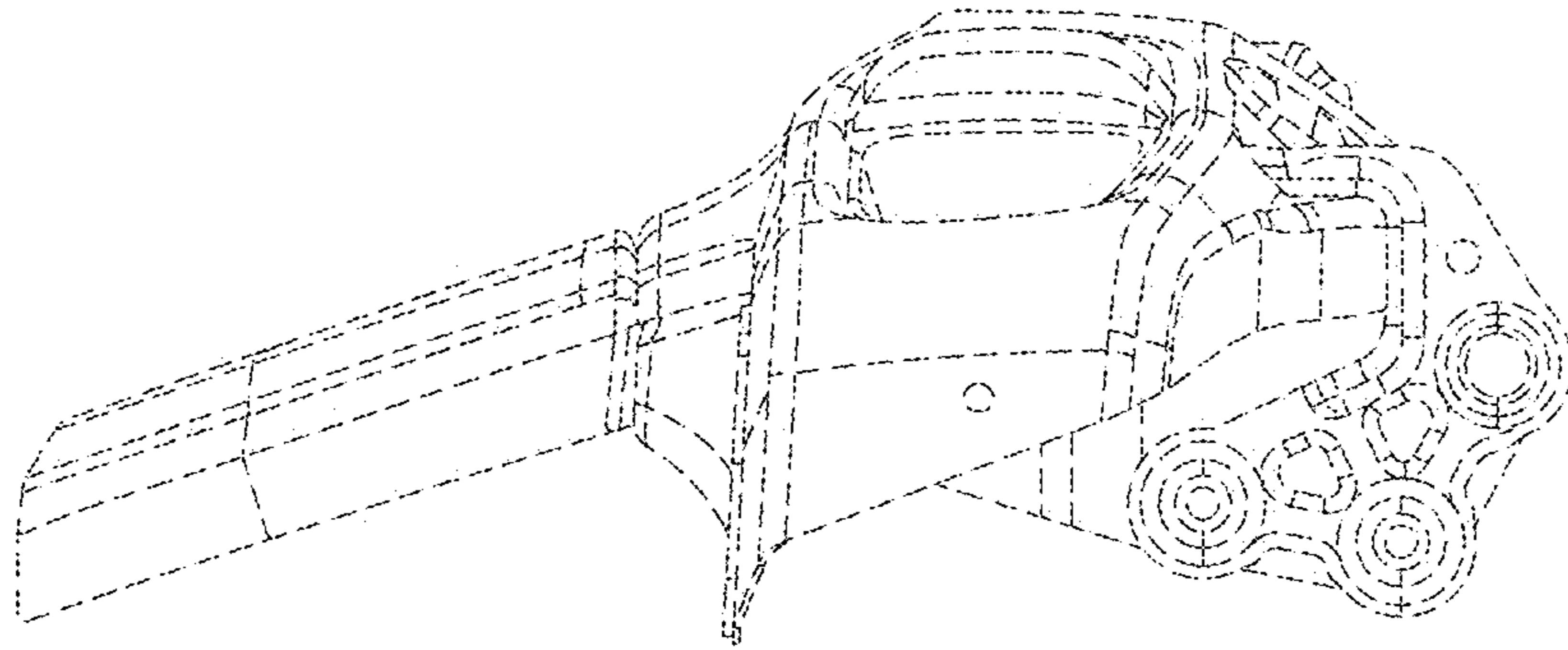

FIG. 13

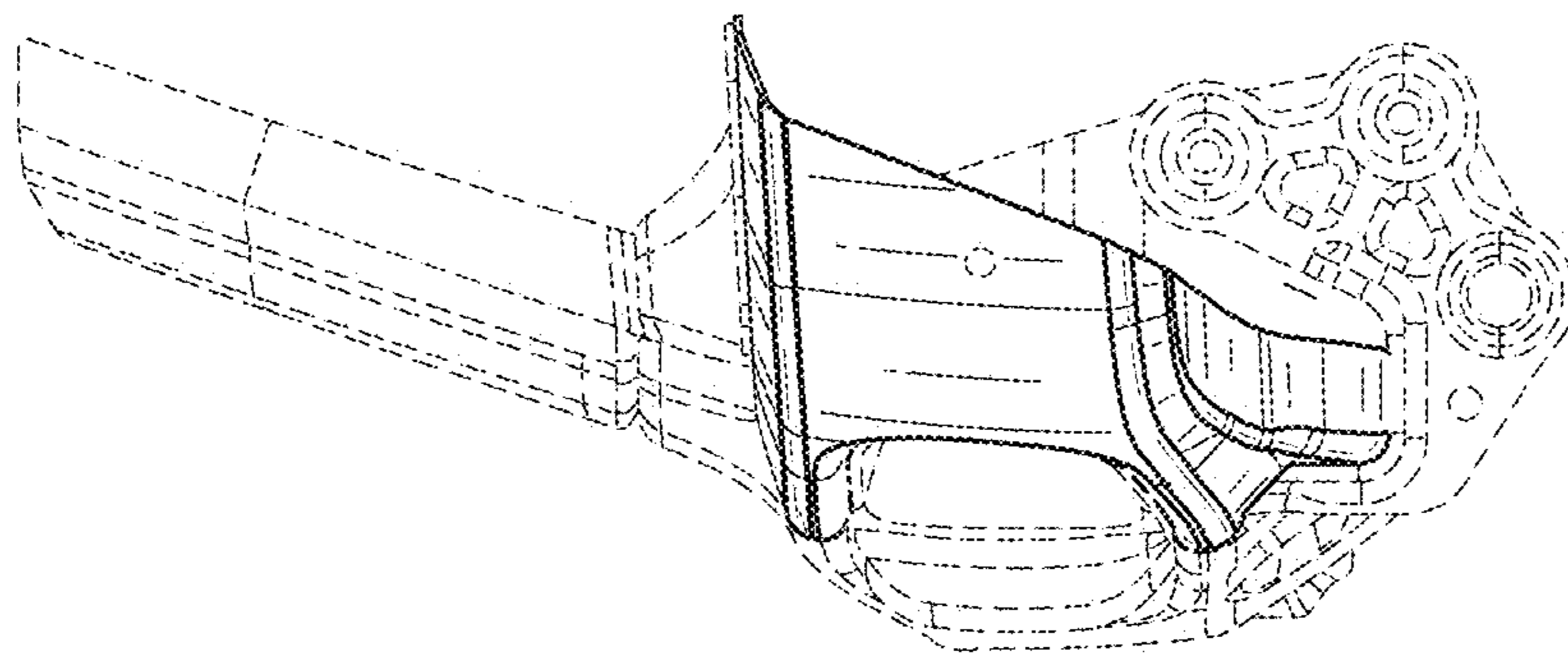

FIG. 12



FIG. 14

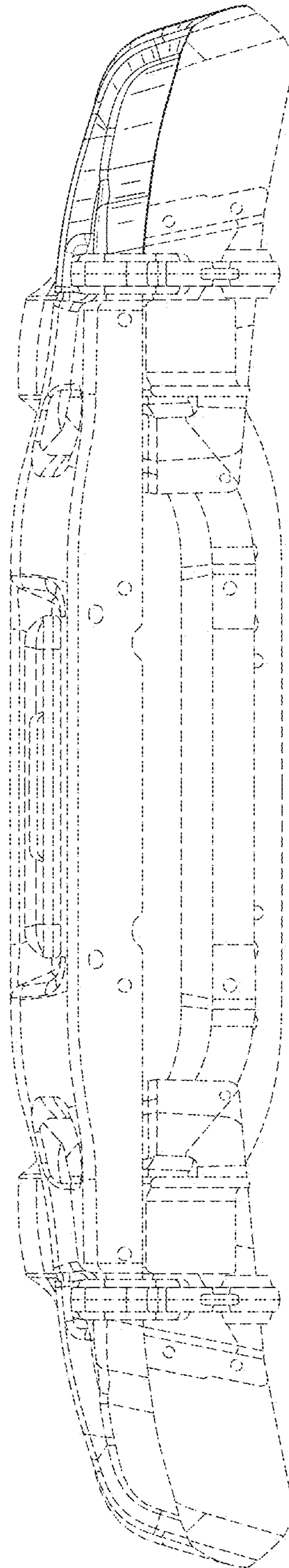

FIG. 15

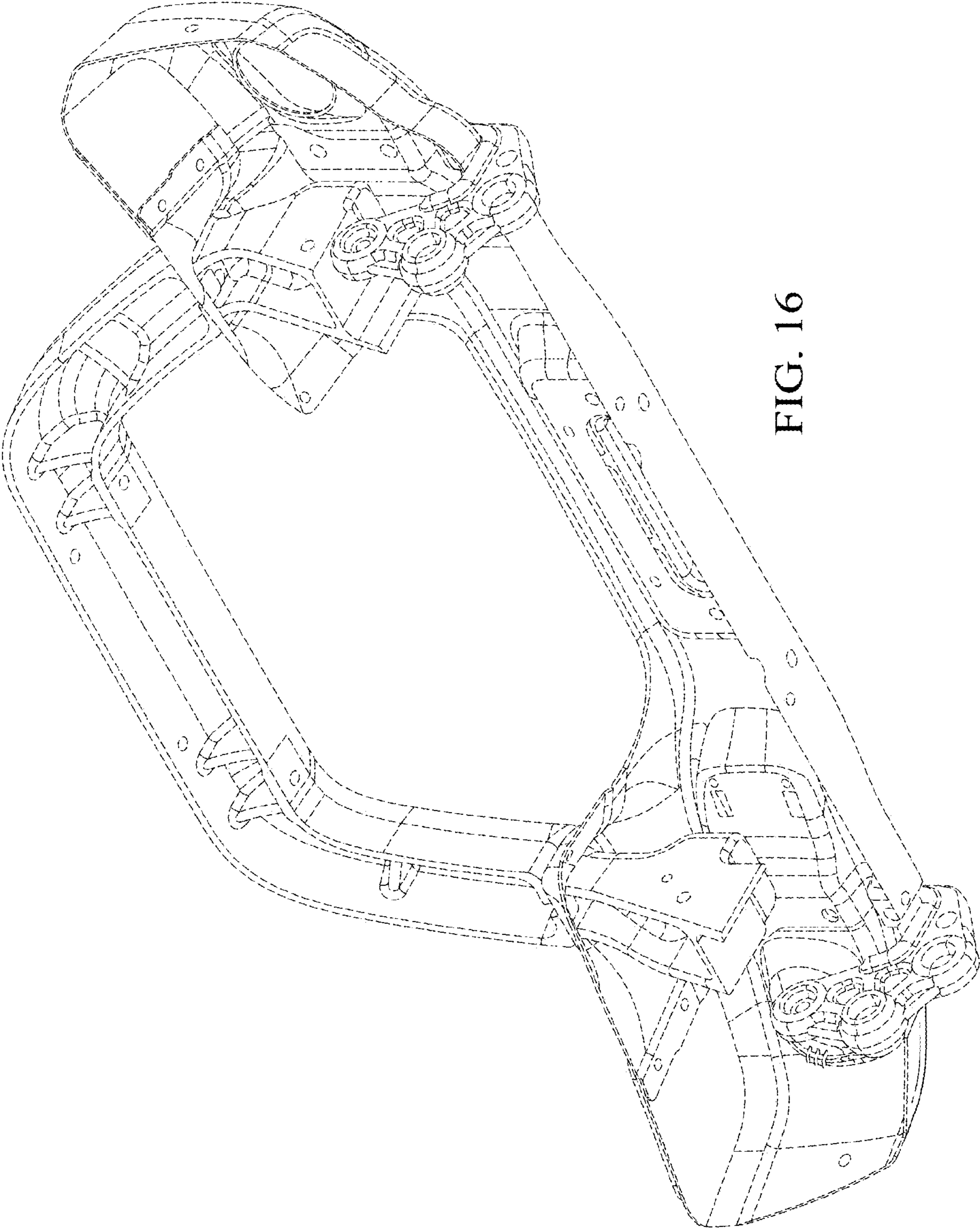

FIG. 16