



US00D908547S

(12) **United States Design Patent**
Kim et al.

(10) **Patent No.:** **US D908,547 S**

(45) **Date of Patent:** **** Jan. 26, 2021**

- (54) **VEHICLE HEAD TUBE**
- (71) Applicant: **SUPER73, INC.**, Irvine, CA (US)
- (72) Inventors: **John Kim**, Irvine, CA (US); **Aaron P. Wong**, Irvine, CA (US); **Legrand Crewse**, Irvine, CA (US)
- (73) Assignee: **Super73, Inc.**, Irvine, CA (US)
- (**) Term: **15 Years**
- (21) Appl. No.: **29/655,286**
- (22) Filed: **Jul. 2, 2018**
- (51) **LOC (13) Cl.** **12-11**
- (52) **U.S. Cl.**
USPC **D12/117**
- (58) **Field of Classification Search**
USPC D12/86, 90, 91, 92, 107, 163, 164, 169,
D12/171, 178, 194, 196, 216, 111,
D12/114-126; D21/533, 538, 561, 562;
D23/259, 262, 266
CPC B26J 17/02; B26J 6/02; B26J 6/005; B60R
19/02; B60R 19/18; B60R 19/24; B60R
19/56
See application file for complete search history.

- 8,439,385 B2 * 5/2013 Baron B62K 5/02
280/288.4
- D686,539 S * 7/2013 Schaible D12/110
- 9,150,101 B2 * 10/2015 Iida B60K 15/07
- D749,024 S * 2/2016 Heinz D12/178
- D760,364 S * 6/2016 Angel D23/262
- 9,994,281 B2 * 6/2018 Kishi B62K 21/02

OTHER PUBLICATIONS

<https://forums.mtbr.com/frame-building/pvd-preview-652294.html>
MTBR site, head tube, Sep. 17, 2010 (Year: 2010).*

* cited by examiner

Primary Examiner — Derrick E Holland

(74) *Attorney, Agent, or Firm* — Stradling Yocca Carlson & Rauth

(57) **CLAIM**

The ornamental design for a vehicle head tube, as shown and described.

DESCRIPTION

FIG. 1 is a perspective view of a vehicle head tube showing the new design;
FIG. 2 is a front view thereof;
FIG. 3 is a rear view thereof;
FIG. 4 is a right side view thereof;
FIG. 5 is a left side view thereof;
FIG. 6 is a top view thereof; and,
FIG. 7 is a bottom view thereof.

1 Claim, 6 Drawing Sheets

(56) **References Cited**

U.S. PATENT DOCUMENTS

- D341,806 S * 11/1993 Loehr 74/551.8
- D515,481 S * 2/2006 McJunkin D12/178
- D658,098 S * 4/2012 Plainfield D12/178
- D682,745 S * 5/2013 Horne D12/111

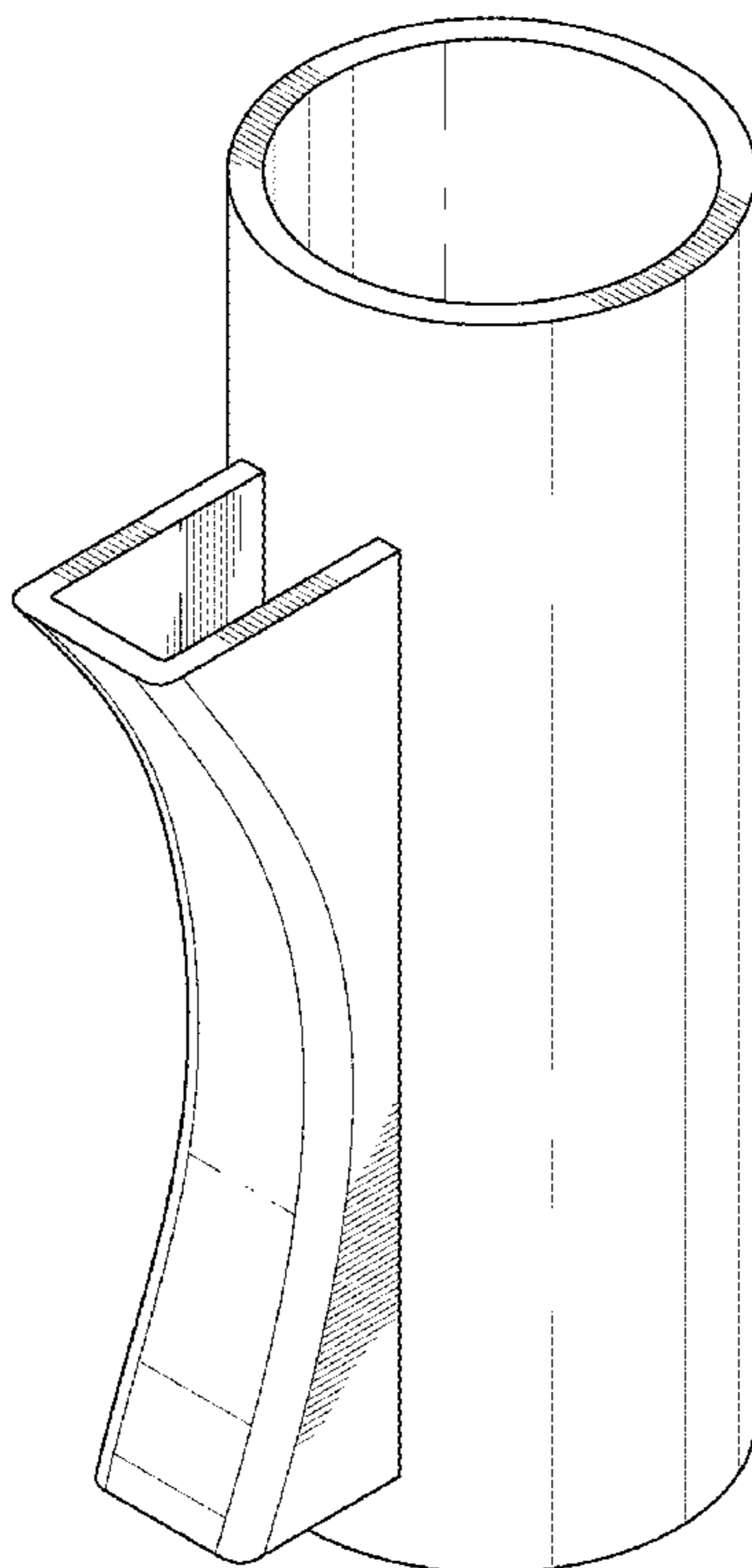
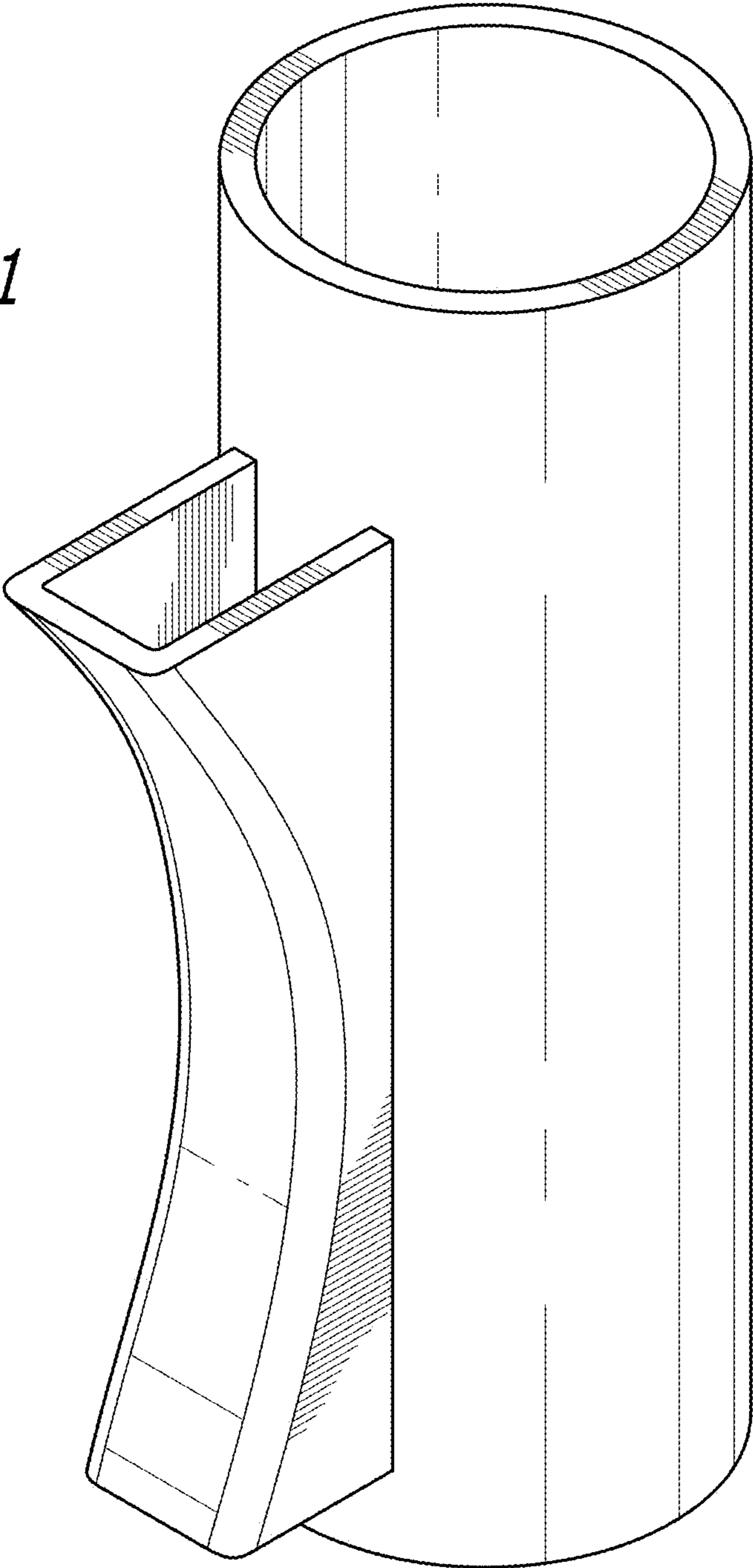

FIG. 1



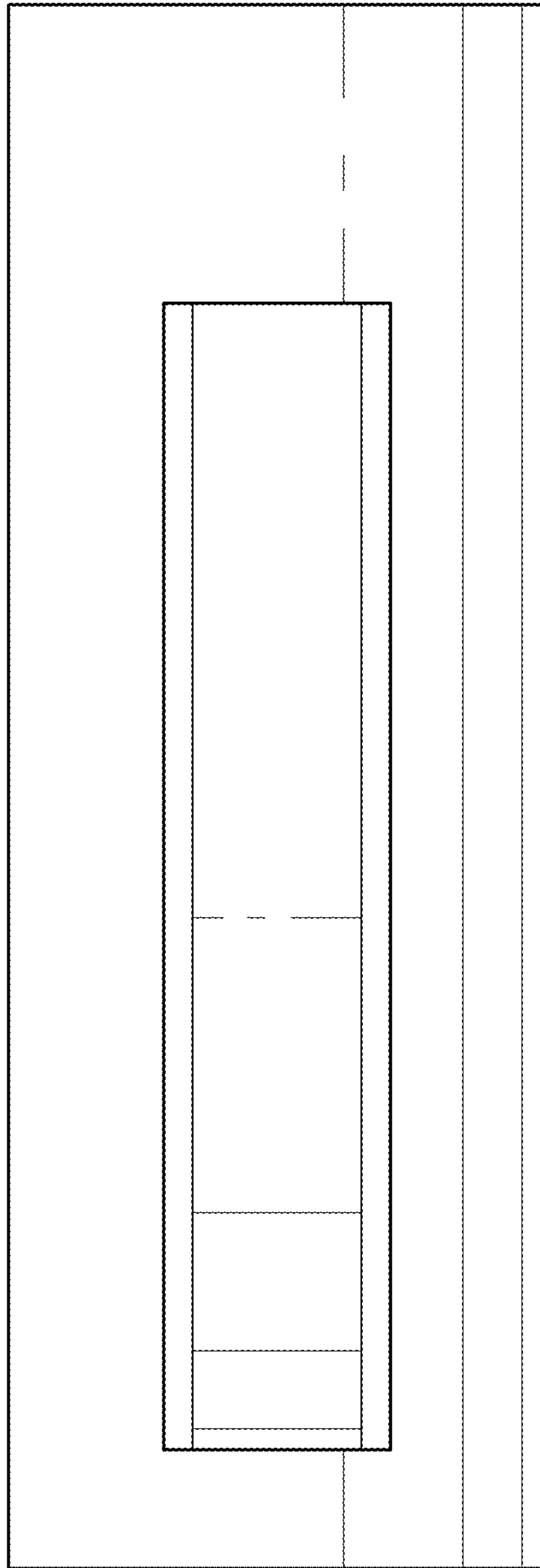

FIG. 2

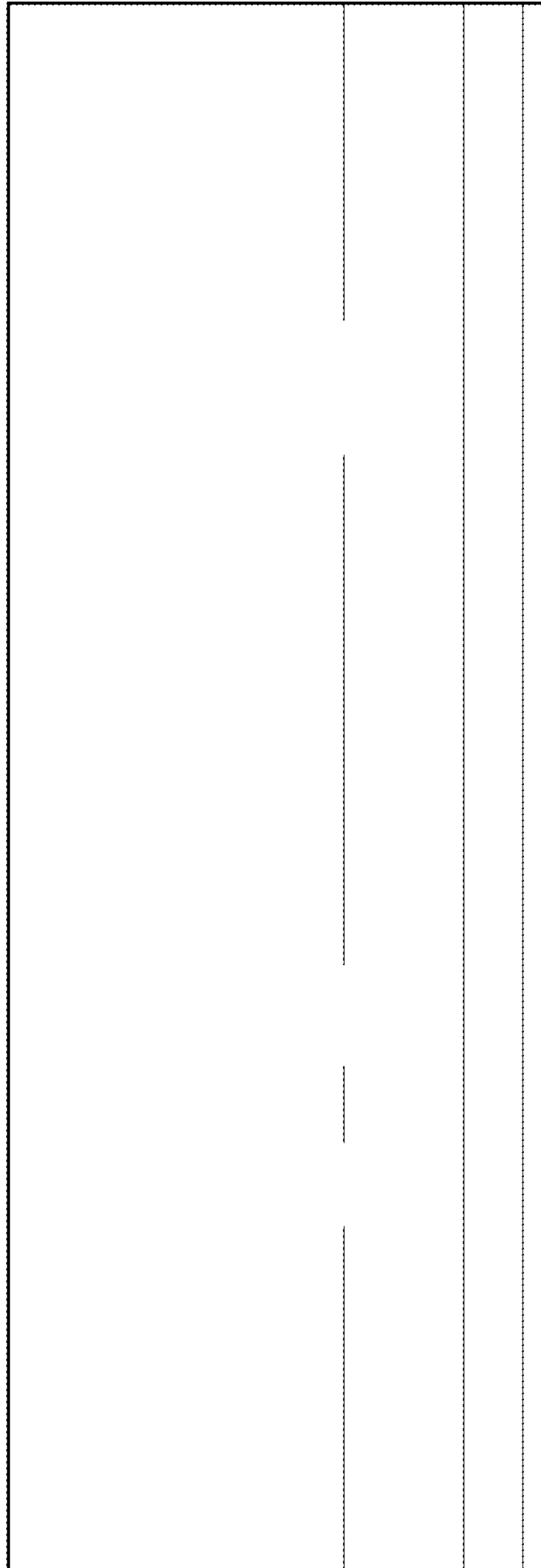

FIG. 3

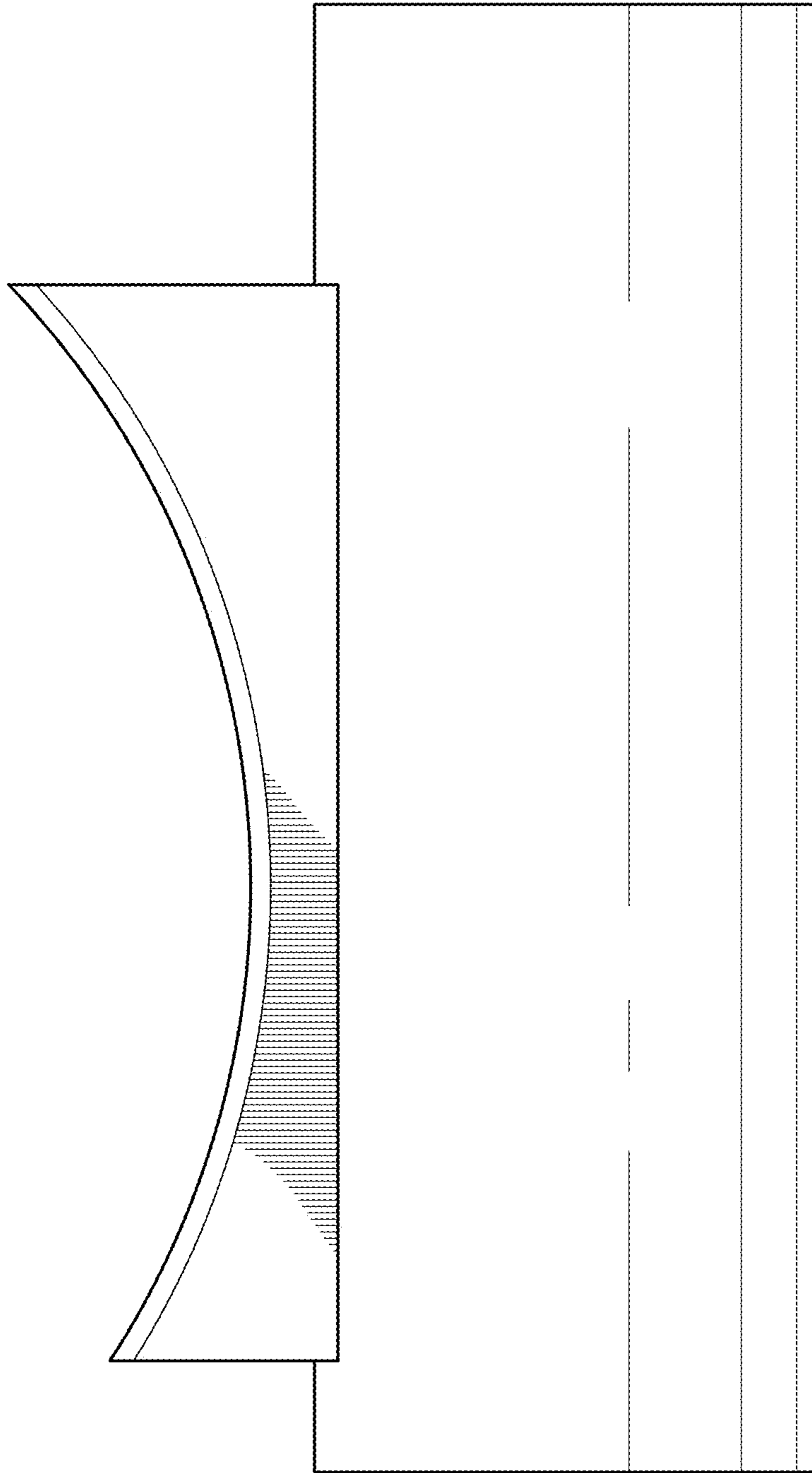

FIG. 4

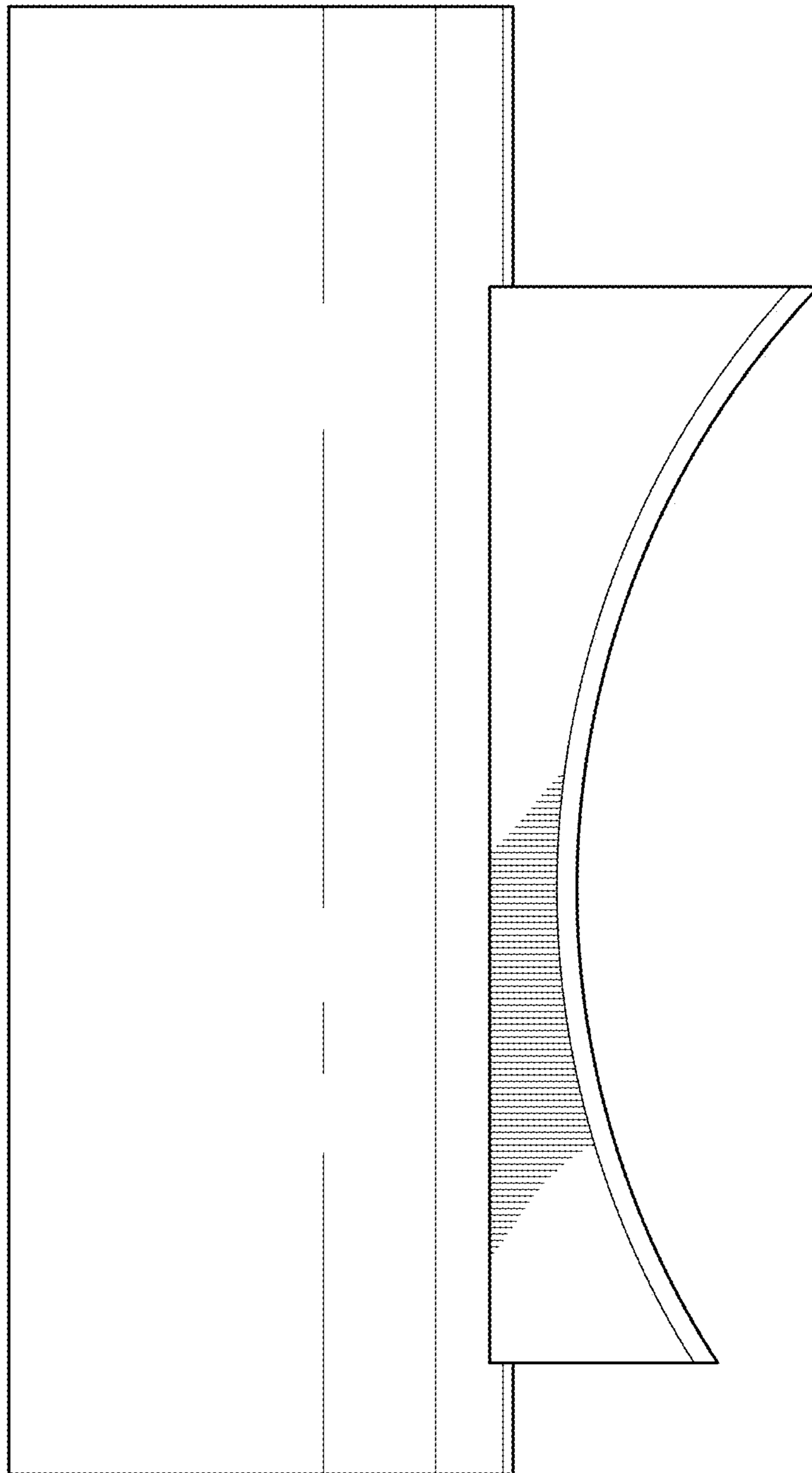

FIG. 5

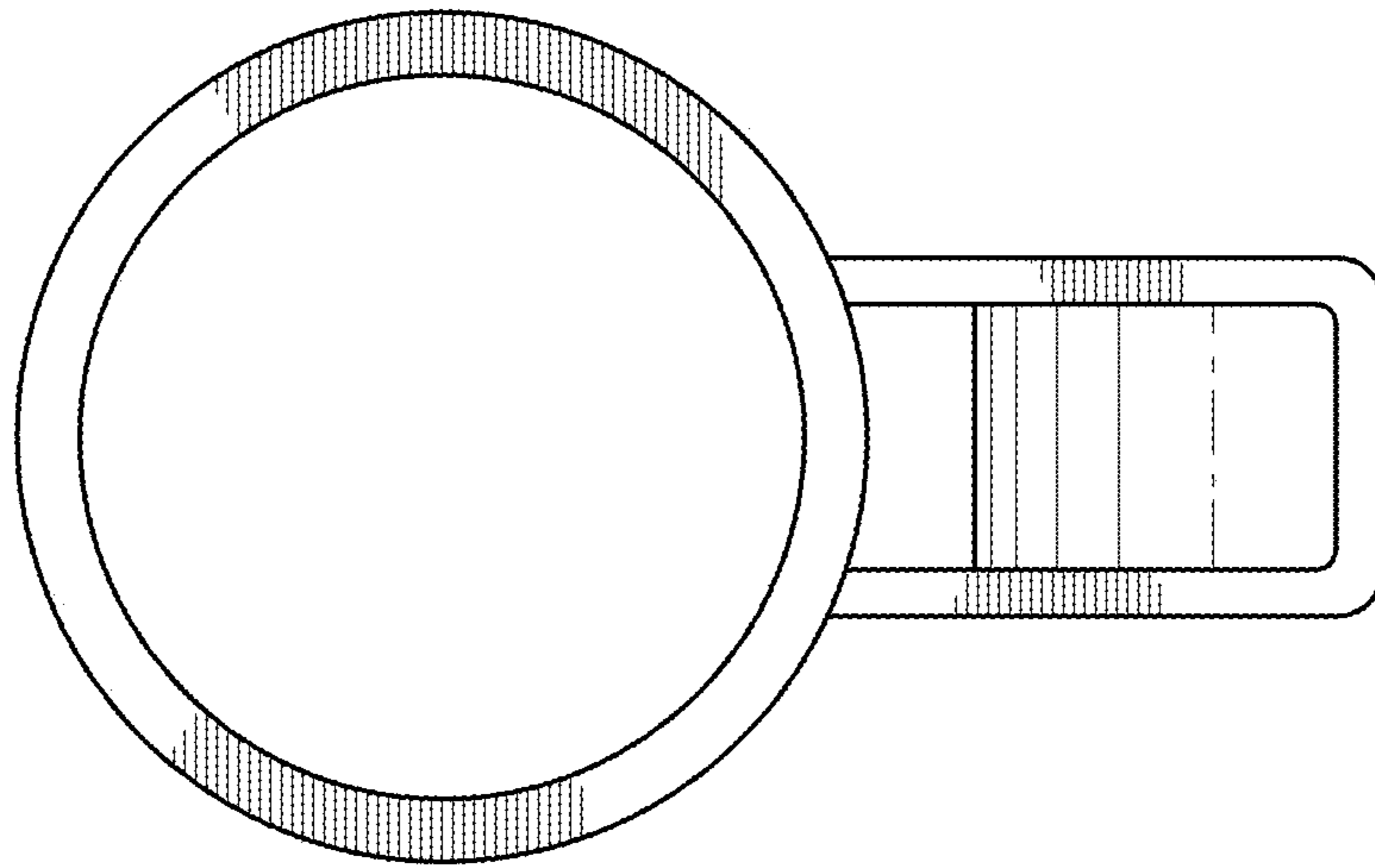

FIG. 6

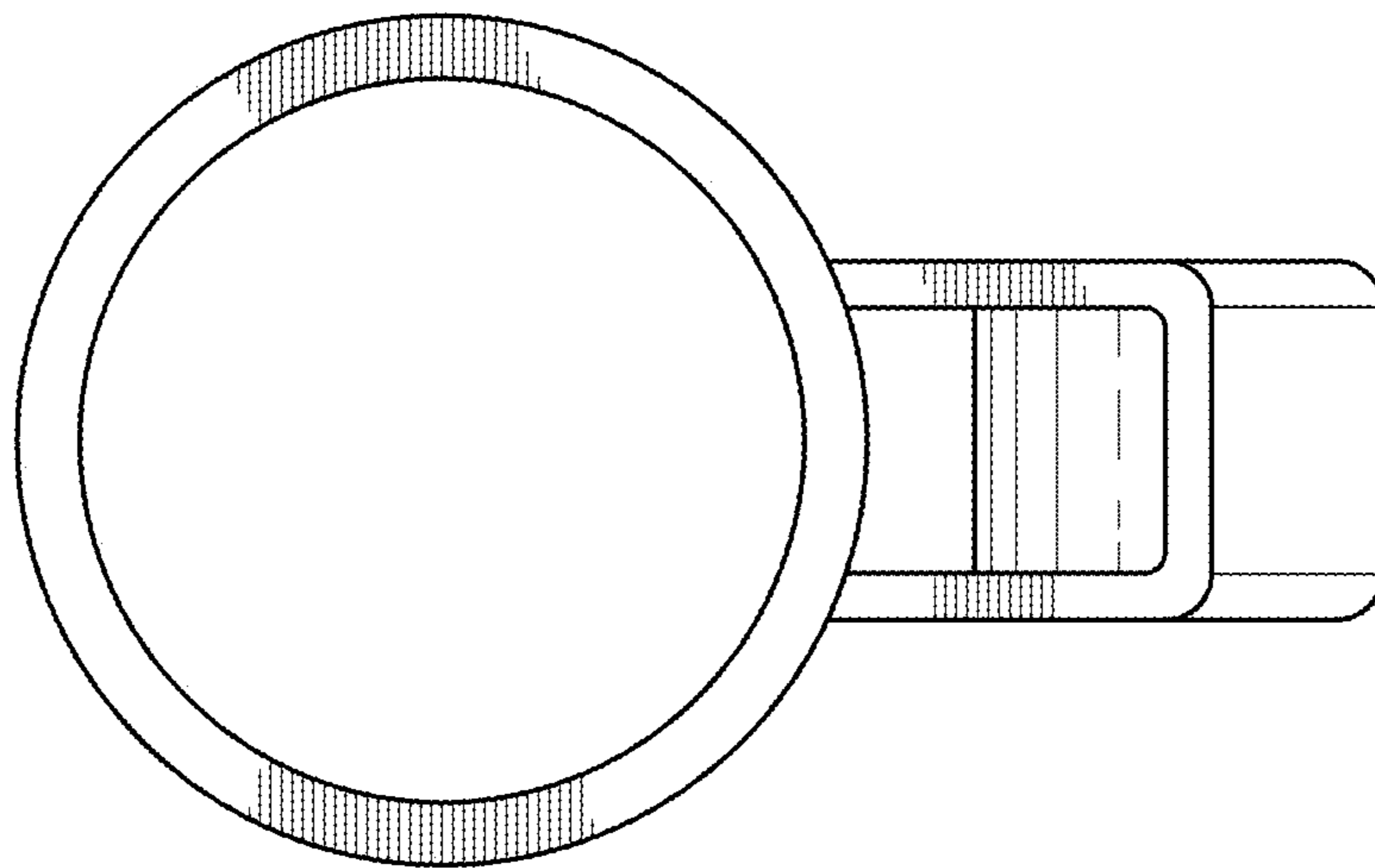

FIG. 7