



US00D908542S

(12) **United States Design Patent**  
**Burney et al.**

(10) **Patent No.:** **US D908,542 S**  
(45) **Date of Patent:** **\*\* Jan. 26, 2021**

(54) **BICYCLE FLEX STAY**

FOREIGN PATENT DOCUMENTS

(71) Applicant: **Cycling Sports Group, Inc.**, Wilton,  
CT (US)

EP 2698310 2/2014  
EP 2828144 8/2019  
EP 3590810 1/2020

(72) Inventors: **Ryan James Burney**, Norwalk, CT  
(US); **Joshua Adrian Hursh**, Norwalk,  
CT (US); **John M. Cramer**, Fairfield,  
CT (US); **Phu-Ern Thomas Heng**,  
Norwalk, CT (US); **Luis Arraiz**,  
Newtown, CT (US)

OTHER PUBLICATIONS

Photographs of commercial products publicly available prior to Sep.  
11, 2017.

(73) Assignee: **Cycling Sports Group, Inc.**, Wilton,  
CT (US)

*Primary Examiner* — Darlington Ly

(74) *Attorney, Agent, or Firm* — Brian G. Gilpin; Godfrey  
& Kahn, S.C.

(\*\*) Term: **15 Years**

(57) **CLAIM**

(21) Appl. No.: **29/698,748**

The ornamental design for a bicycle flex stay, substantially  
as shown and described.

(22) Filed: **Jul. 19, 2019**

**DESCRIPTION**

(51) **LOC (13) Cl.** ..... **12-11**

(52) **U.S. Cl.**  
USPC ..... **D12/111**

(58) **Field of Classification Search**  
USPC ..... D12/111, 117; D21/412, 414, 419,  
D21/423–428  
CPC ..... B62K 3/00; B62K 3/02; B62K 3/06  
See application file for complete search history.

FIG. 1 is a top, front, and right side perspective view of a  
bicycle flex stay embodying our new design;  
FIG. 2 is a bottom, rear, and left side perspective view  
thereof;  
FIG. 3 is a left side elevation view thereof;  
FIG. 4 is a right side elevation view thereof;  
FIG. 5 is a rear elevation view thereof;  
FIG. 6 is a front elevation view thereof;  
FIG. 7 is a top plan view thereof;  
FIG. 7A is a top plan view thereof, in which the environ-  
mental broken line showing of the top seat stay has been  
omitted to provide a complete view;  
FIG. 8 is a bottom plan view thereof; and,  
FIG. 9 is a left side elevation view thereof, when attached to  
and shown as part of an exemplary bicycle frame.  
The broken lines in the figures showing additional portions  
of a bicycle frame depict the environment in which the  
claimed bicycle flex stay is used and form no part of the  
claimed design.

(56) **References Cited**

U.S. PATENT DOCUMENTS

5,098,114 A \* 3/1992 Jones ..... B62K 19/06  
280/284  
5,441,292 A \* 8/1995 Busby ..... B62K 25/30  
280/284  
5,509,679 A 4/1996 Leitner  
5,678,837 A 10/1997 Leitner  
5,699,480 A 12/1997 Martin  
5,797,613 A \* 8/1998 Busby ..... B62K 25/04  
280/284  
5,865,456 A 2/1999 Busby et al.  
(Continued)

**1 Claim, 10 Drawing Sheets**

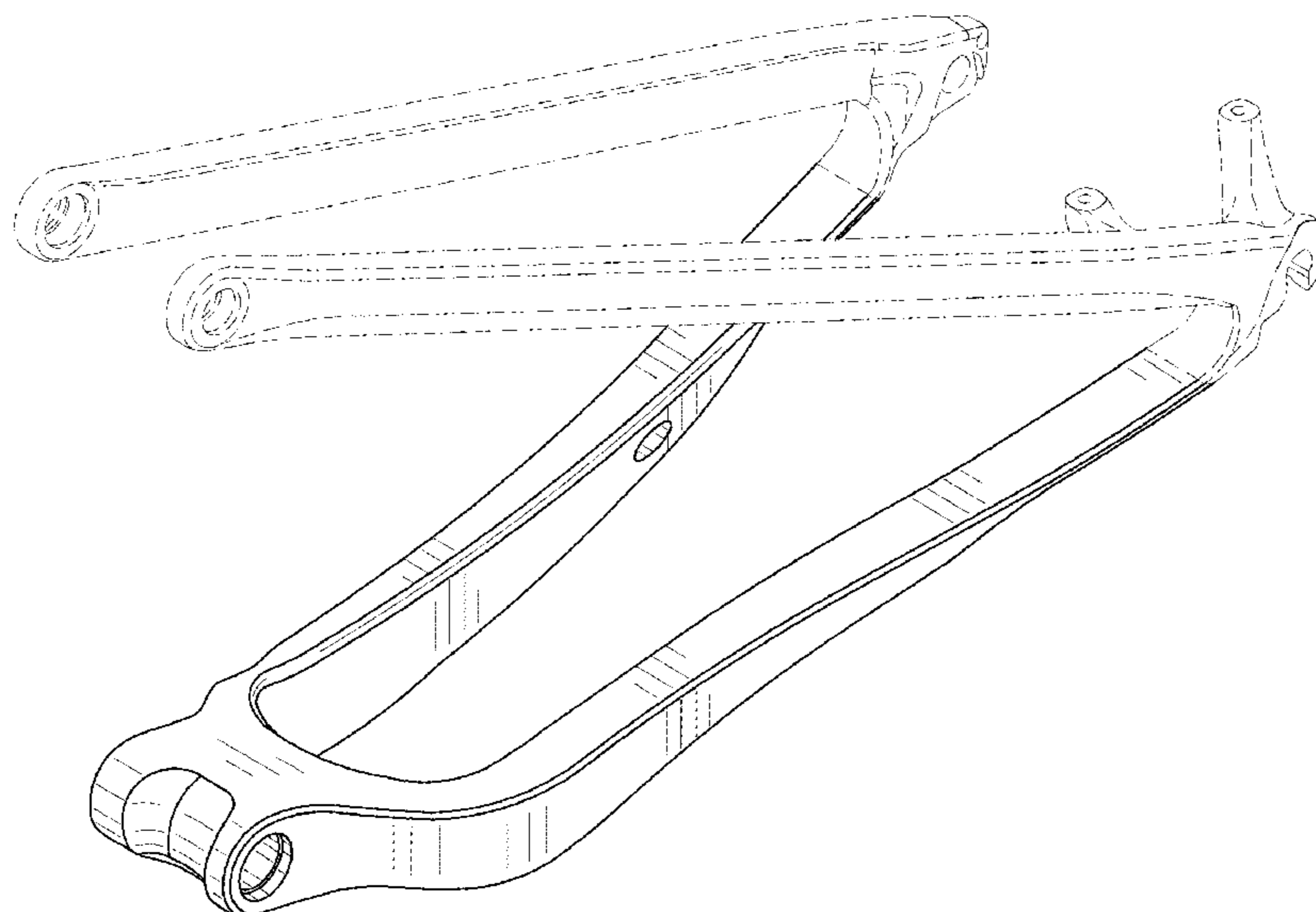

(56)

**References Cited**

## U.S. PATENT DOCUMENTS

5,947,499 A \* 9/1999 Busby ..... B62K 19/18  
267/270  
6,076,845 A 6/2000 Lawwill et al.  
6,092,823 A 7/2000 Busby  
6,406,048 B1 6/2002 Castellano  
6,783,142 B1 8/2004 Schober  
6,805,373 B2 \* 10/2004 Singenberger ..... B62K 19/34  
280/281.1  
D508,442 S \* 8/2005 Endo ..... D12/127  
7,140,628 B2 11/2006 Parkin  
7,195,088 B2 \* 3/2007 Matsueda ..... B62K 25/30  
180/206.5  
D635,062 S \* 3/2011 Savola ..... D12/127  
D637,527 S \* 5/2011 Choi ..... D12/111  
D691,927 S \* 10/2013 Lumpkin ..... D12/111  
8,925,949 B2 \* 1/2015 Zecchetto ..... B62K 19/00  
280/281.1  
D722,285 S \* 2/2015 Silva ..... D12/111  
8,998,235 B2 4/2015 Beale  
D738,261 S \* 9/2015 Silva ..... D12/111  
9,150,272 B1 \* 10/2015 Thompson ..... B62M 6/45  
9,290,229 B2 \* 3/2016 Thompson ..... B62K 25/02  
9,302,732 B2 4/2016 Beale  
D776,014 S \* 1/2017 Silva ..... D12/111  
D783,460 S \* 4/2017 Beale ..... D12/111  
D785,509 S \* 5/2017 Juhlin ..... D12/111  
D801,875 S \* 11/2017 Pfeiffer ..... D12/111  
10,086,899 B2 \* 10/2018 Hartung ..... B62K 3/04  
D858,359 S \* 9/2019 Lentz ..... D12/111  
D865,574 S \* 11/2019 Russell ..... D12/111

\* cited by examiner

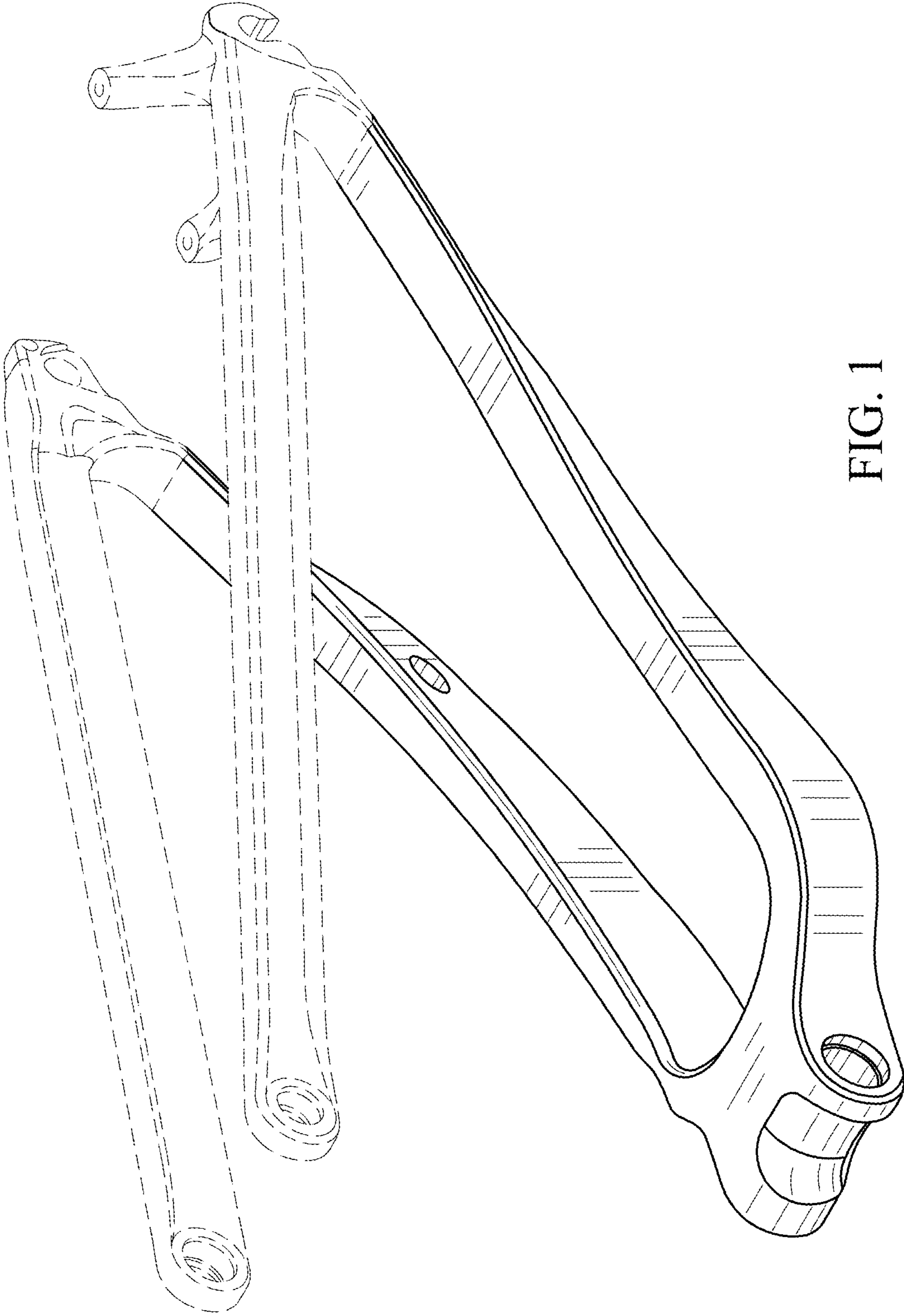

FIG. 1

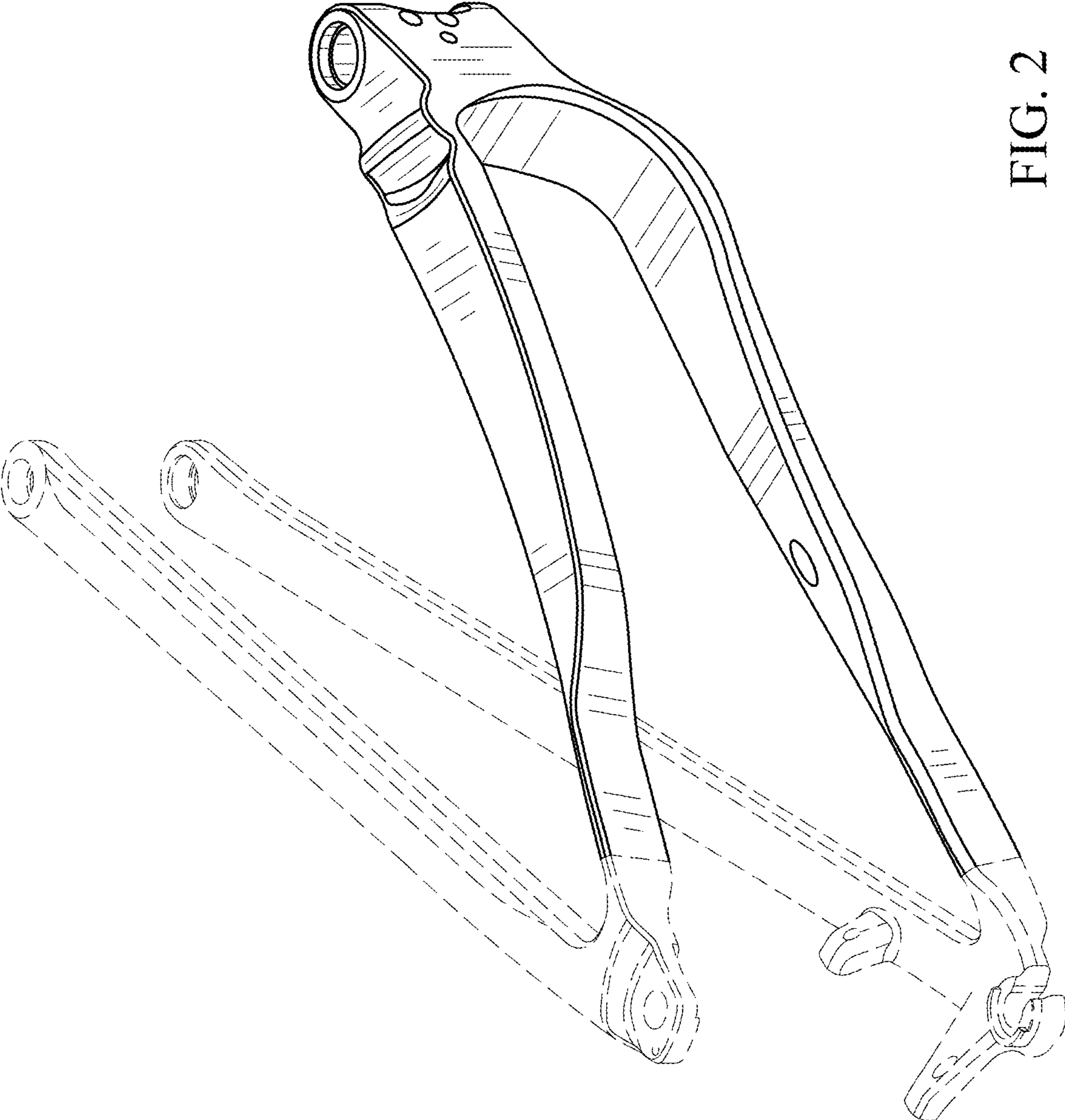

FIG. 2

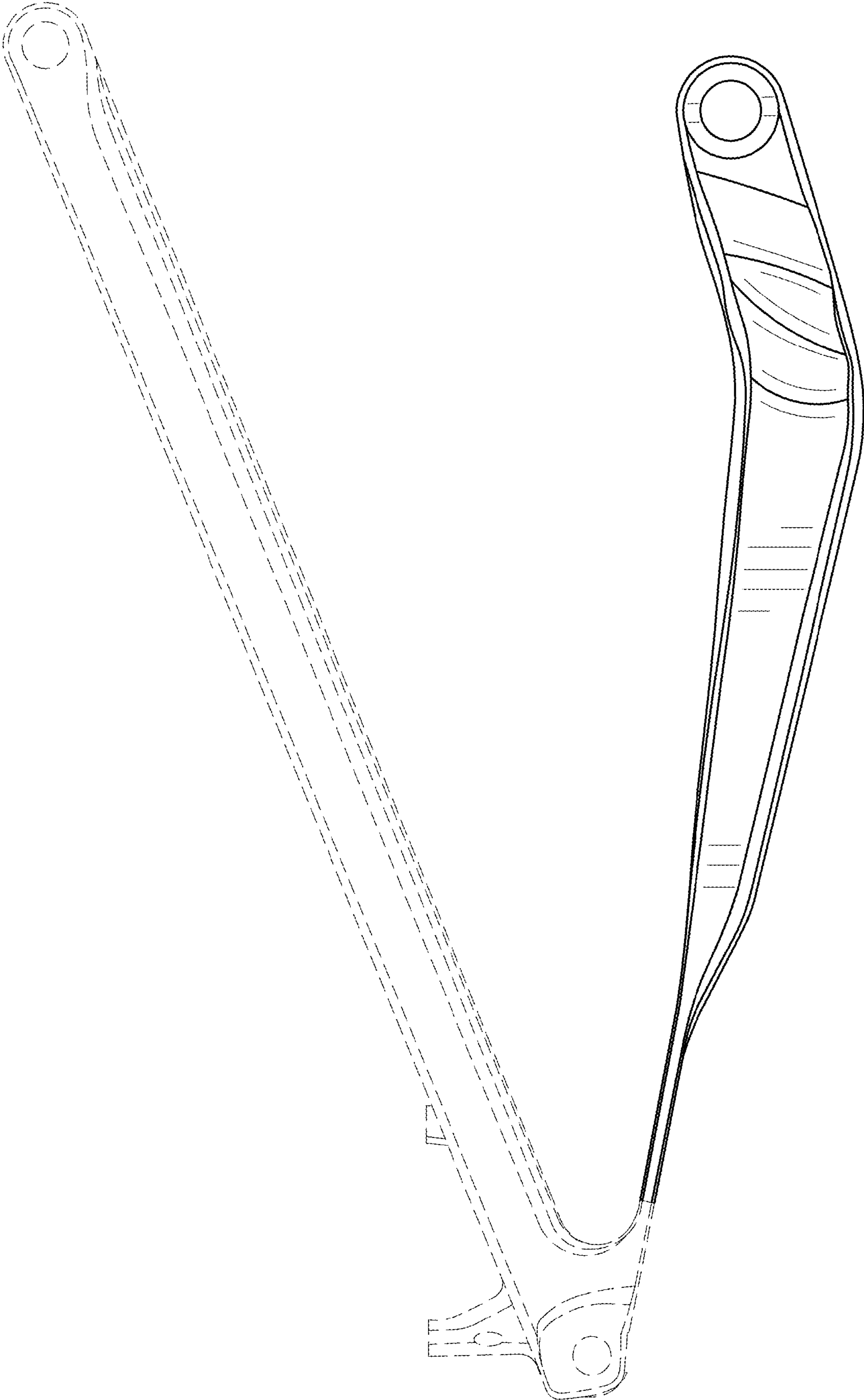

FIG. 3

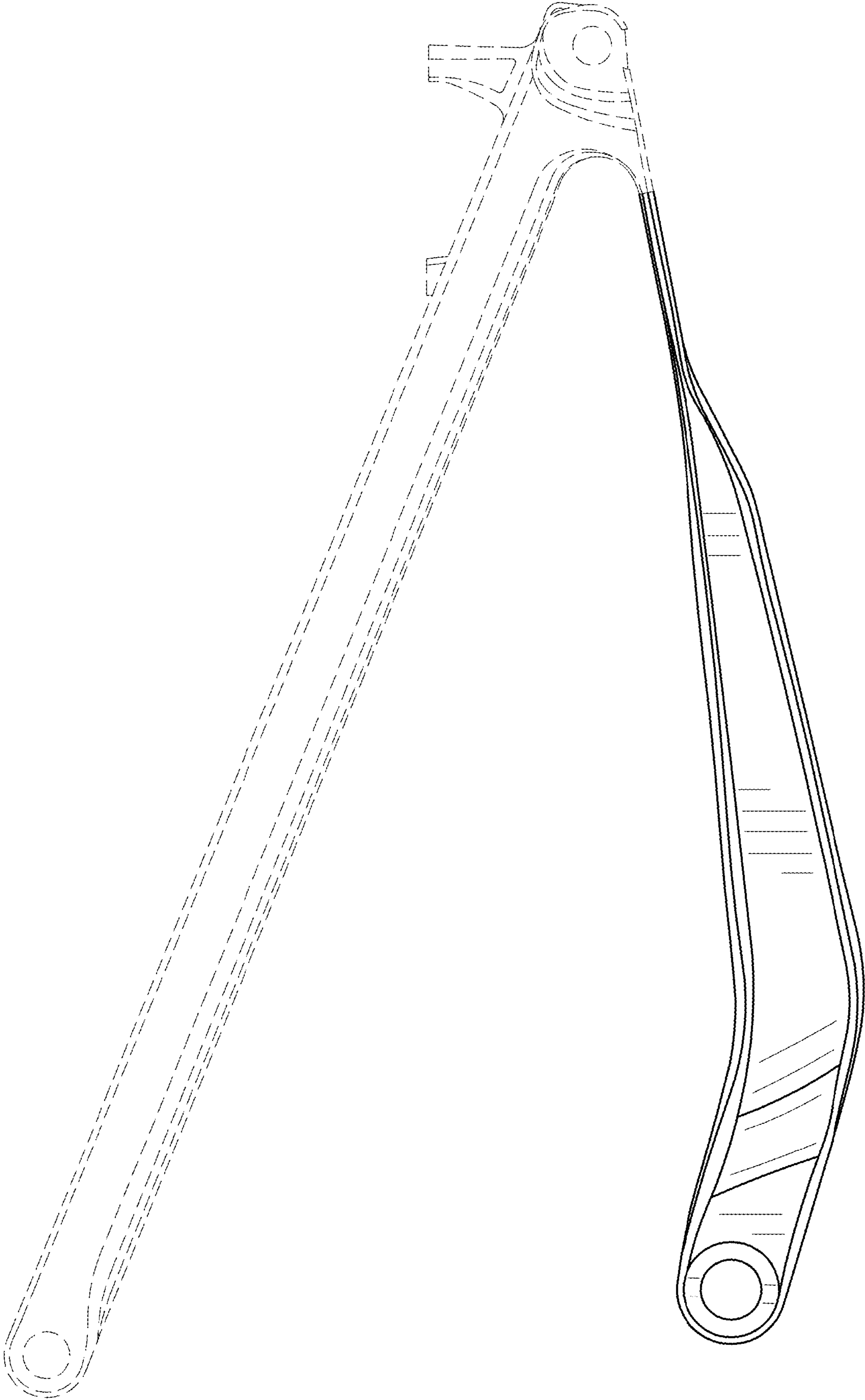

FIG. 4

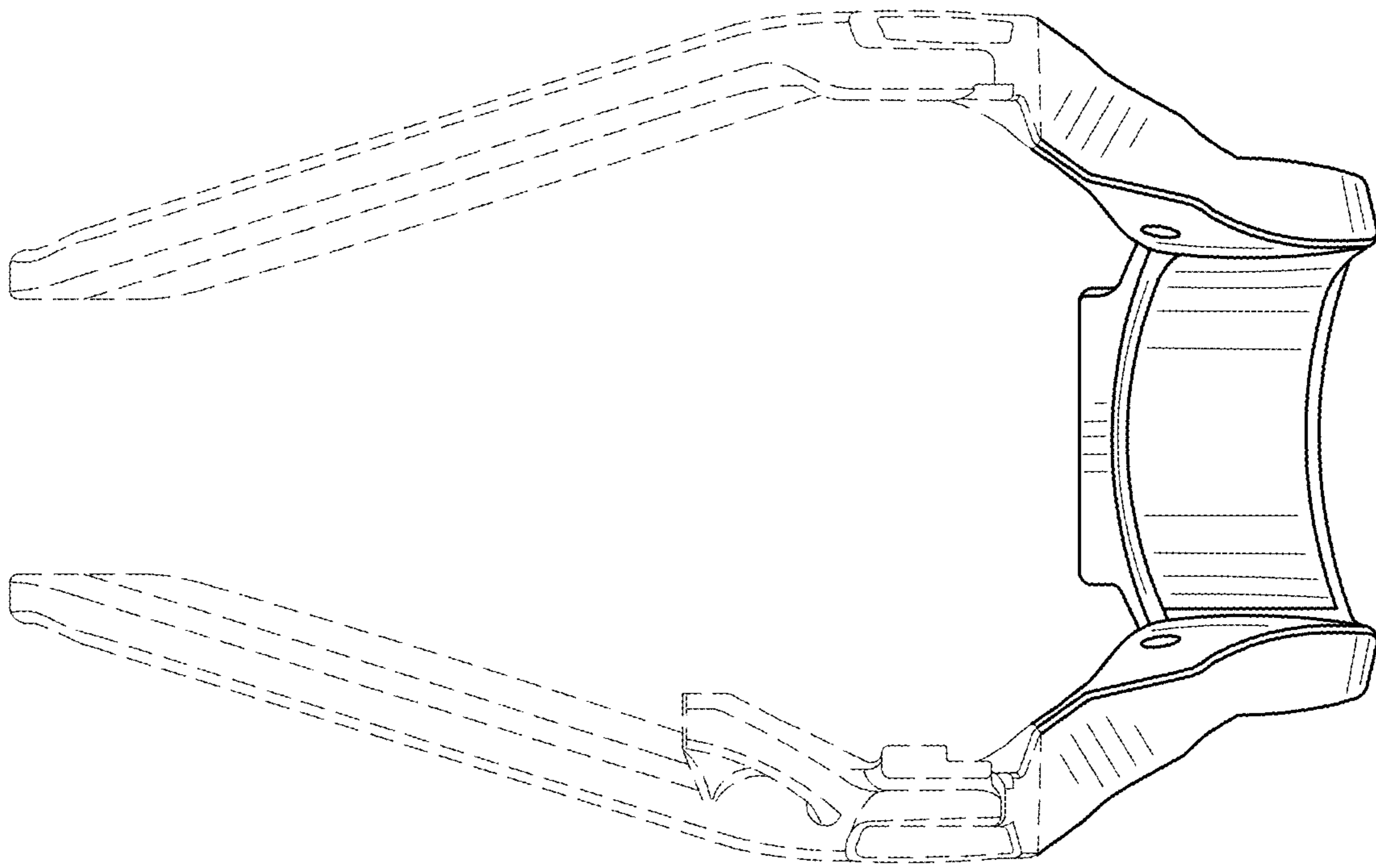

FIG. 5

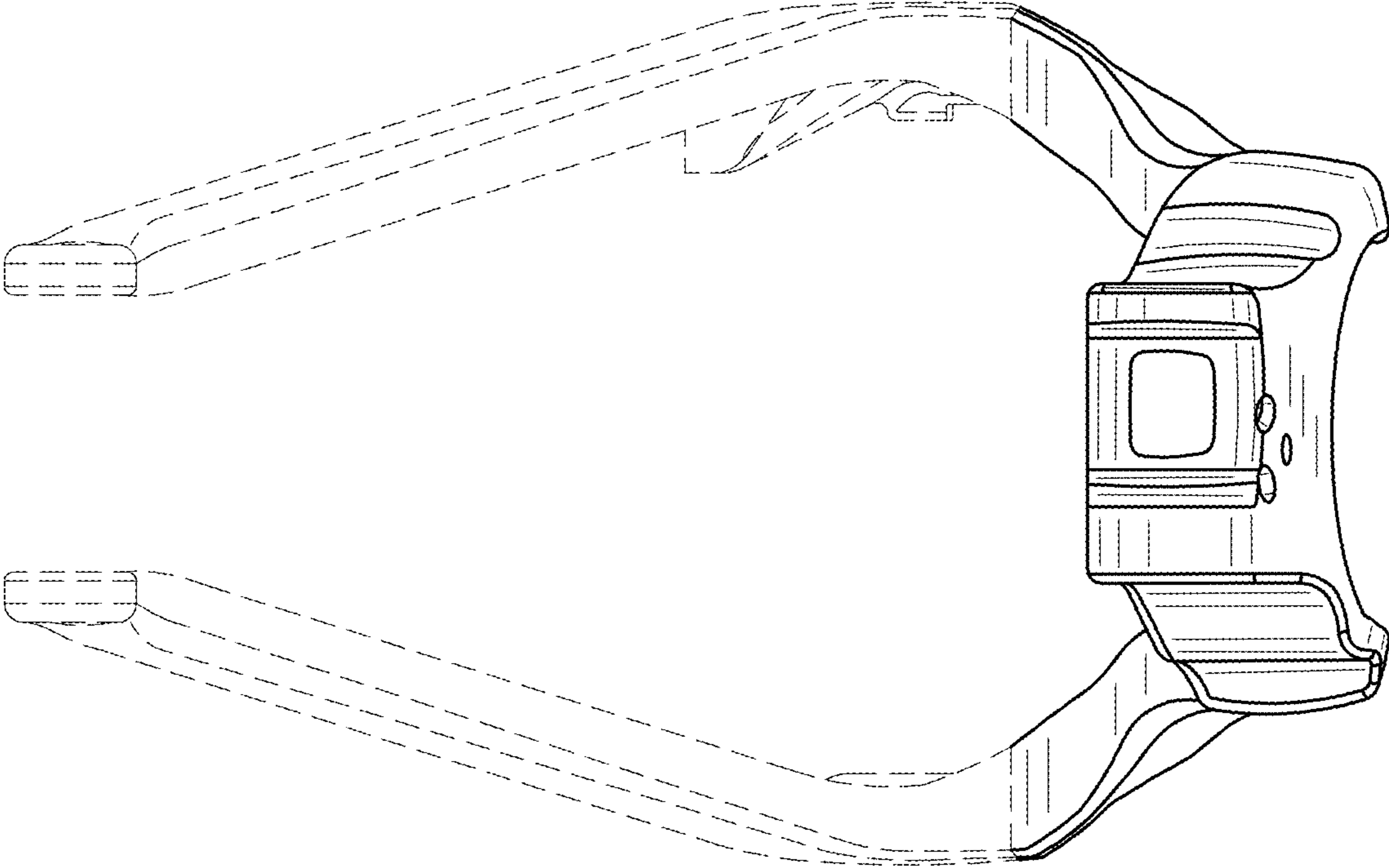

FIG. 6



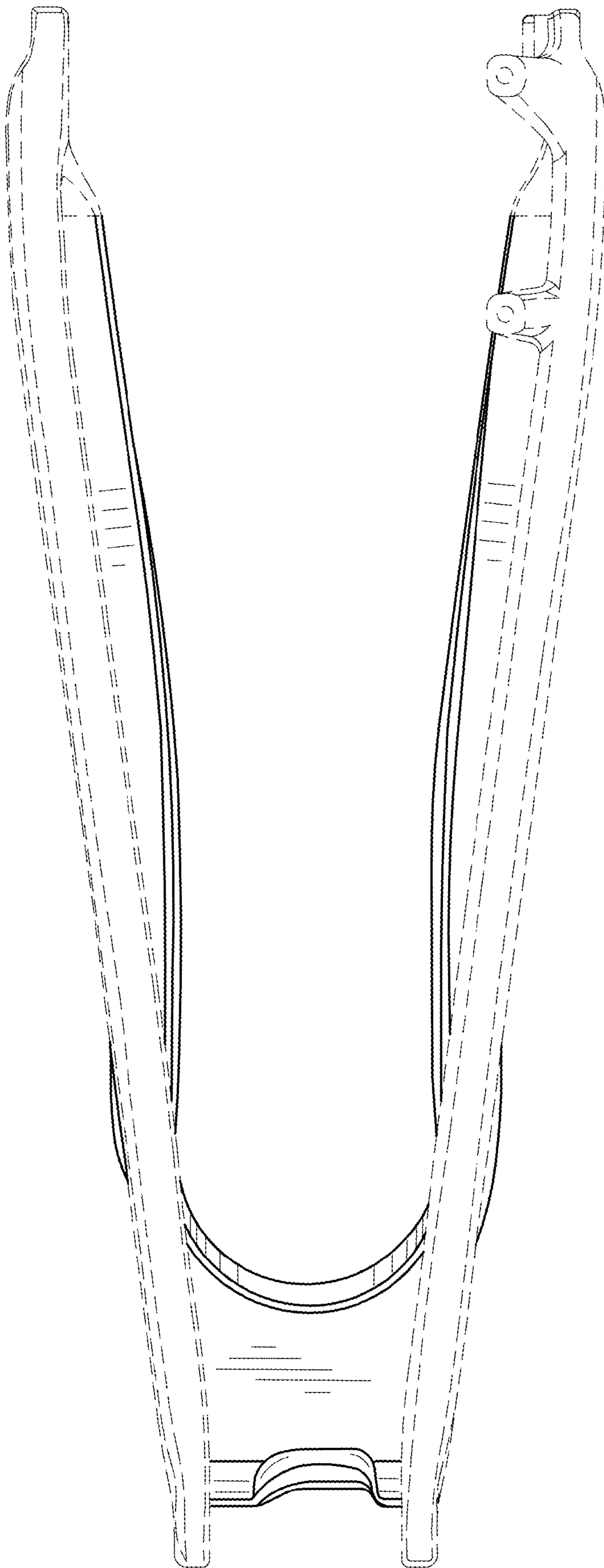

FIG. 7

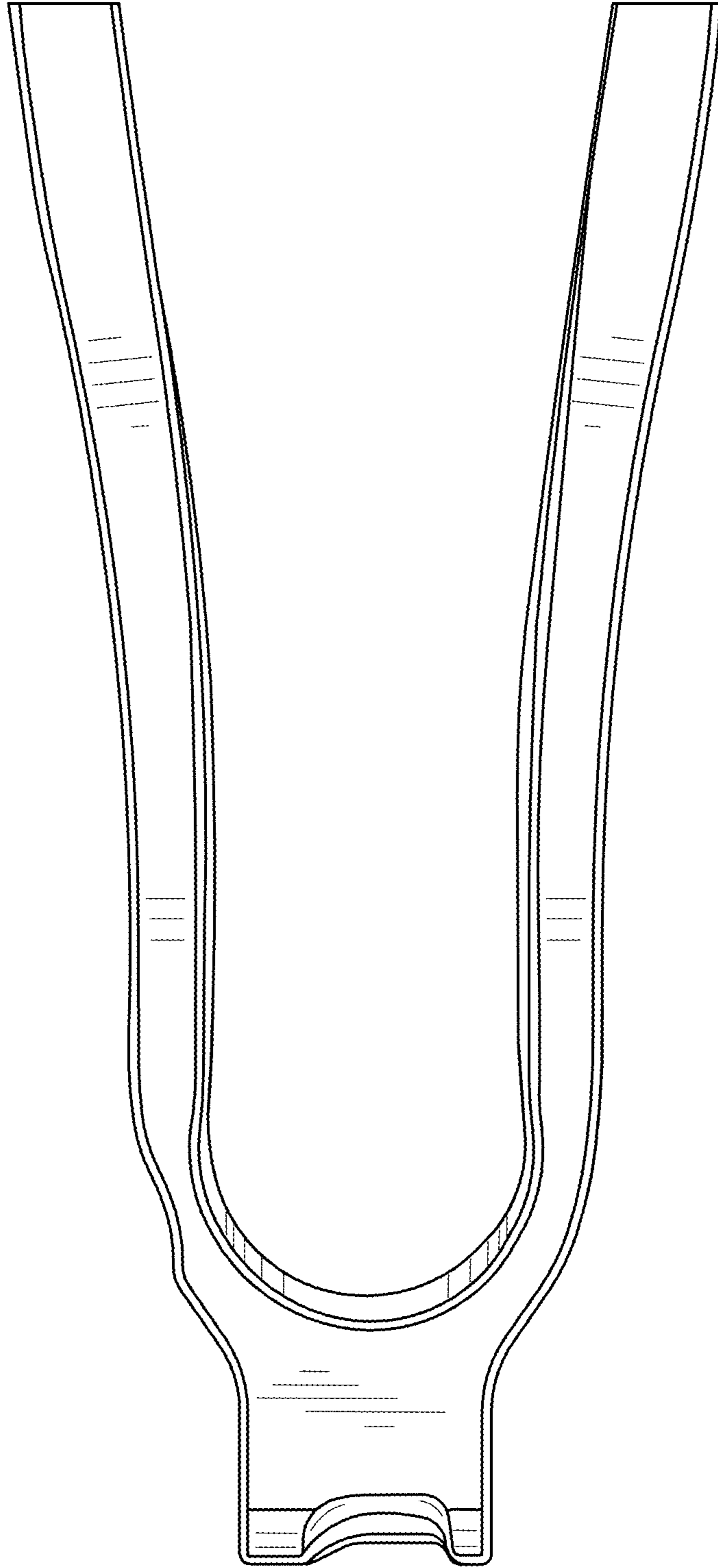

FIG. 7A

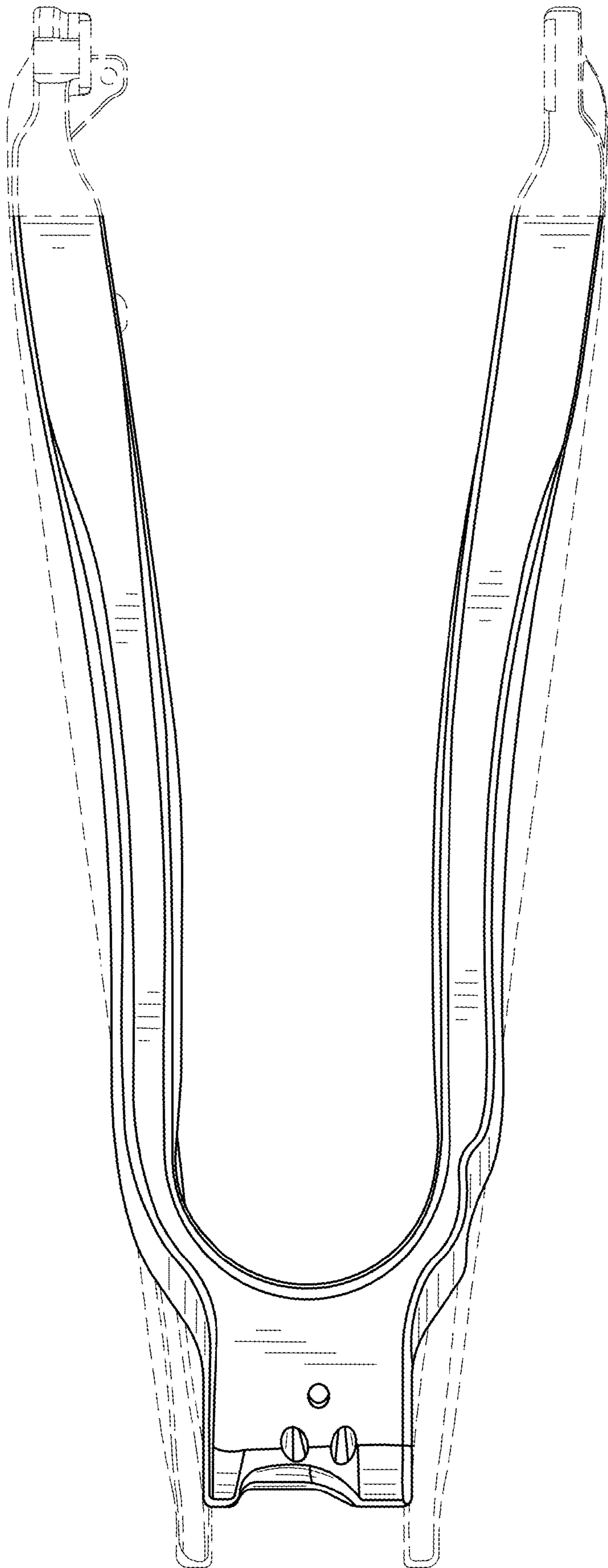

FIG. 8

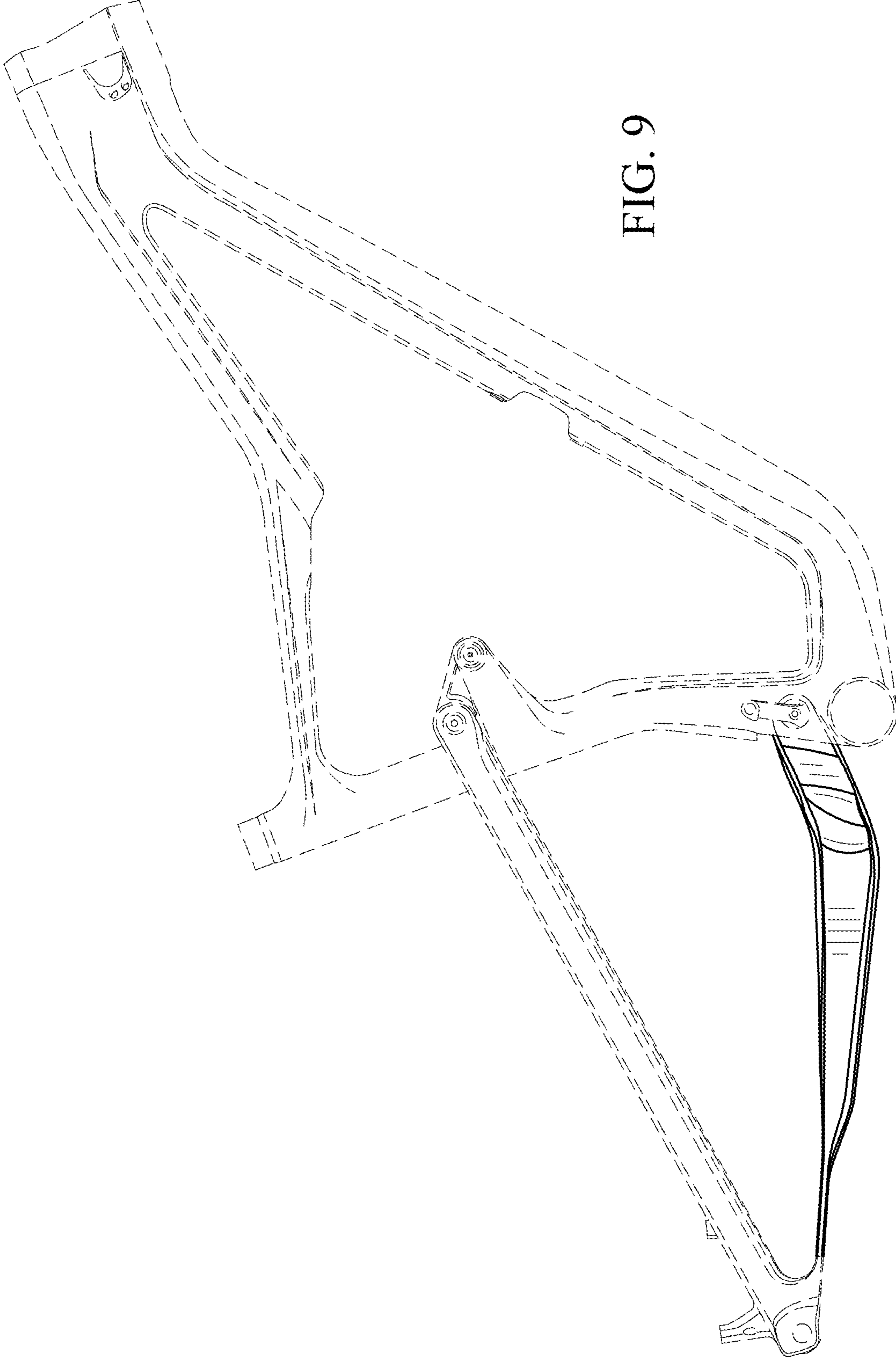

FIG. 9