



US00D908343S

(12) **United States Design Patent** (10) **Patent No.:** **US D908,343 S**
Russo (45) **Date of Patent:** **** Jan. 26, 2021**

(54) **CRAFT PLATFORM**

D752,339 S * 3/2016 Hoover D3/23
D782,180 S * 3/2017 Eberhard D3/18
D826,544 S * 8/2018 Yip D3/18

(71) Applicant: **Deanna Russo**, North Kingstown, RI (US)

* cited by examiner

(72) Inventor: **Deanna Russo**, North Kingstown, RI (US)

Primary Examiner — Steven J Czyz
(74) *Attorney, Agent, or Firm* — Alan F. Feeney, Esq.;
Feeney IP Law

(**) Term: **15 Years**

(57) **CLAIM**

(21) Appl. No.: **29/642,619**

I claim the ornamental design for a craft platform, as shown and described.

(22) Filed: **Mar. 30, 2018**

DESCRIPTION

(51) **LOC (13) Cl.** **02-07**

(52) **U.S. Cl.**
USPC **D3/23**

(58) **Field of Classification Search**
USPC D3/18–29; D6/556, 557, 558, 682.1,
D6/682.2; D11/143, 146, 147, 148
CPC D05B 91/14; D05B 91/16; D05B 91/12;
A01G 5/02; A47G 7/00; A47G 7/041
See application file for complete search history.

FIG. 1 is an upper perspective view of a craft platform;
FIG. 2 is a lower perspective view thereof;
FIG. 3 is a front elevation view thereof, with the rear, left, and right views being identical;
FIG. 4 is a top plan view thereof;
FIG. 5 is a bottom plan view thereof;
FIG. 6 is an enlarged upper perspective view of the flower stem portion of the craft platform, shown separately for ease of disclosure;
FIG. 7 is an enlarged lower perspective view thereof;
FIG. 8 is another enlarged lower perspective view thereof, shown with the middle unclaimed section removed for ease of disclosure;
FIG. 9 is an enlarged side elevation view thereof, with all other side views being identical;
FIG. 10 is an enlarged top plan view thereof; and,
FIG. 11 is an enlarged bottom plan view thereof.

(56) **References Cited**

U.S. PATENT DOCUMENTS

D121,721 S * 7/1940 Ligh et al. D3/18
D236,643 S * 9/1975 Ross et al. D11/130
D297,595 S * 9/1988 Sawai D3/20
D317,884 S * 7/1991 Spicer D11/147
5,375,370 A * 12/1994 Zimmerman A47G 7/07
248/188
D354,869 S * 1/1995 Salyer D6/680
D403,532 S * 1/1999 Moser D6/682.2
D450,442 S * 11/2001 Leonard D3/18
D503,609 S * 4/2005 Robbins, III D14/484
D505,256 S * 5/2005 Nepp D3/25
D572,625 S * 7/2008 Doan D11/146
D573,787 S * 7/2008 Sweet D3/23
D598,322 S * 8/2009 Kunz D11/147
D741,591 S * 10/2015 Shainwald D3/26

In the drawings, the evenly-spaced broken lines depict portions of the article that form no part of the claim. The stippling represents a textured surface that forms no part of the claimed design. It is understood that the apertures are identical in size, shape and depth and are evenly spaced about the top surface of the craft platform.

1 Claim, 9 Drawing Sheets

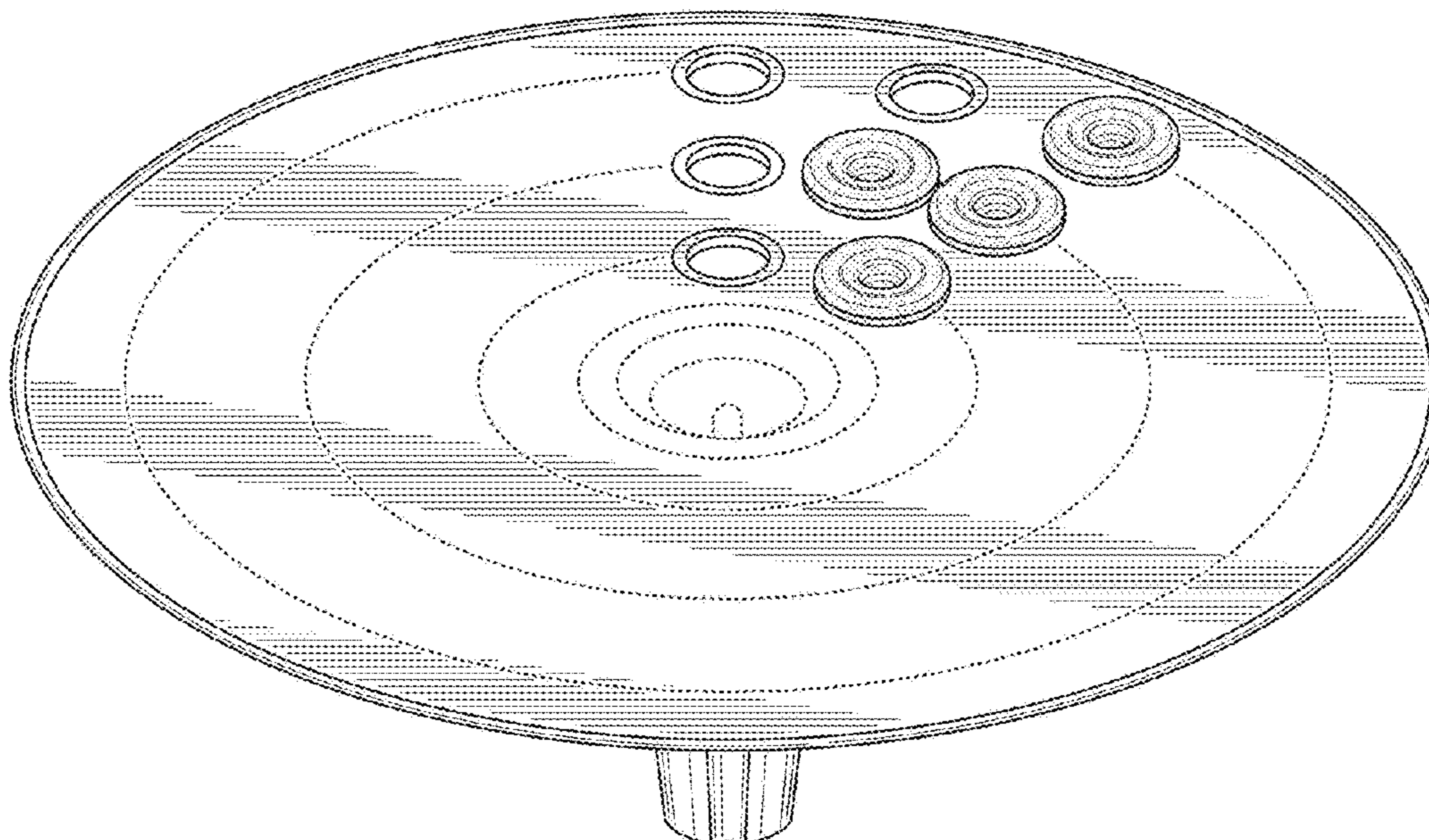

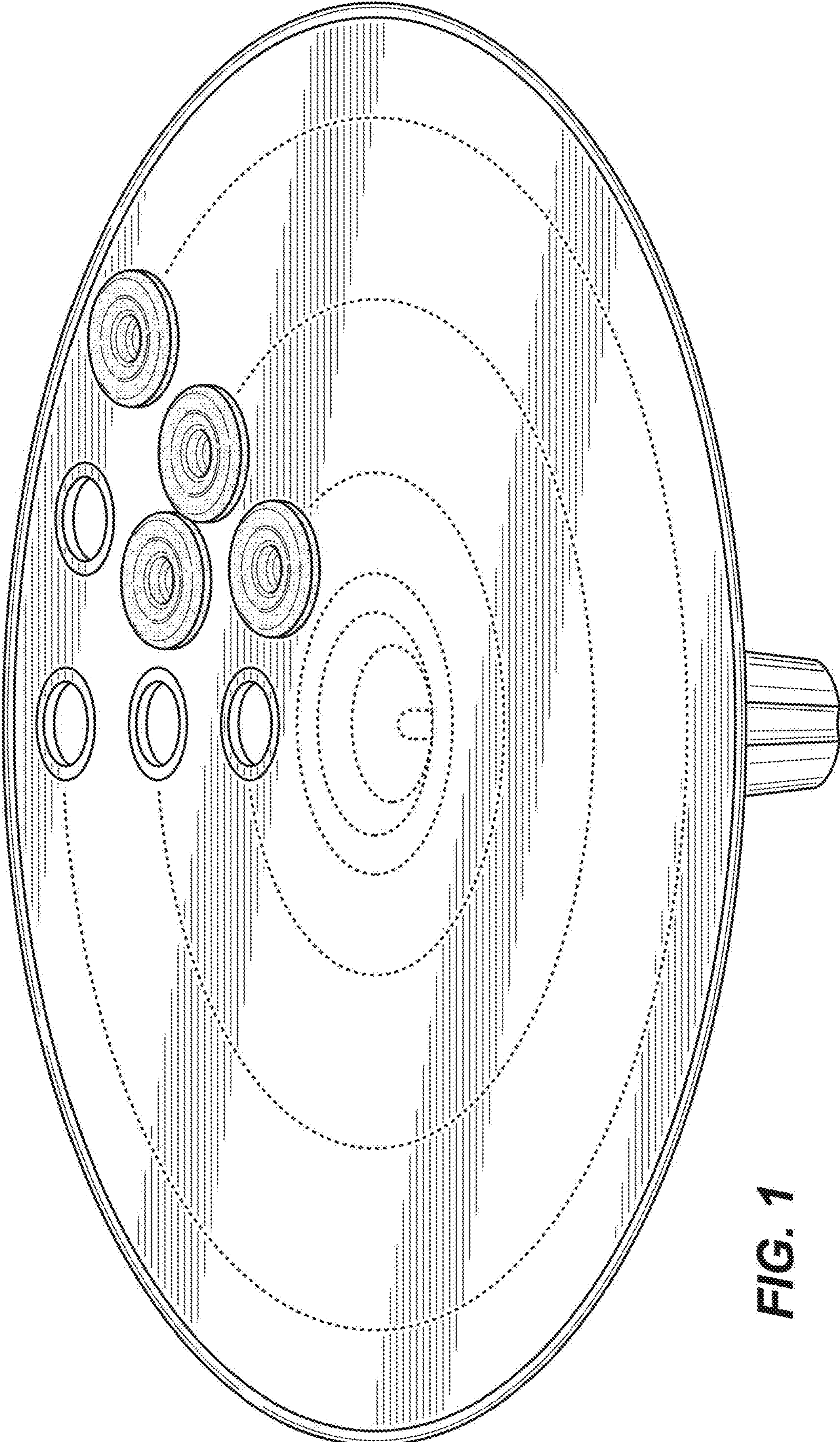

FIG. 1

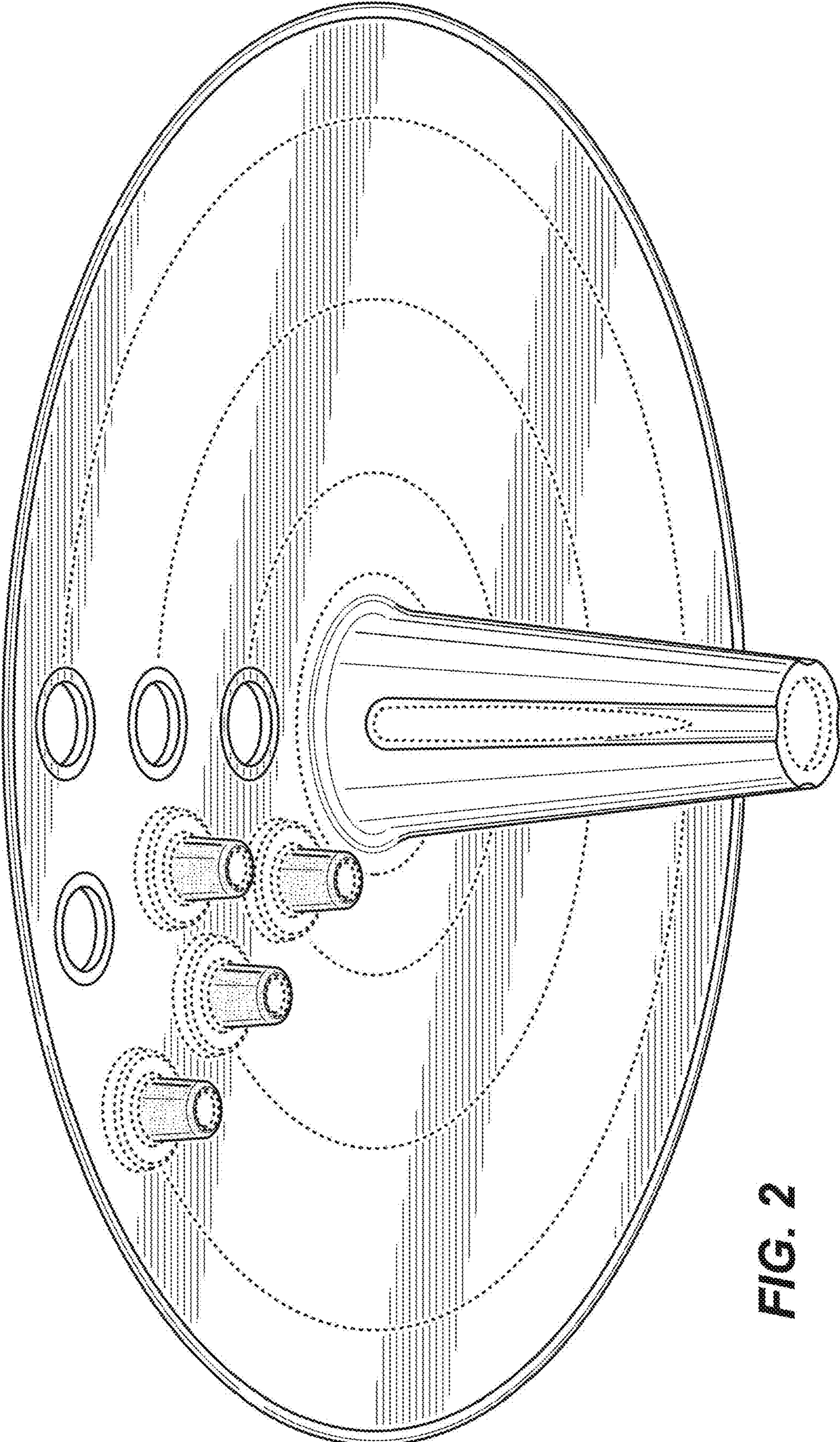

FIG. 2

FIG. 4

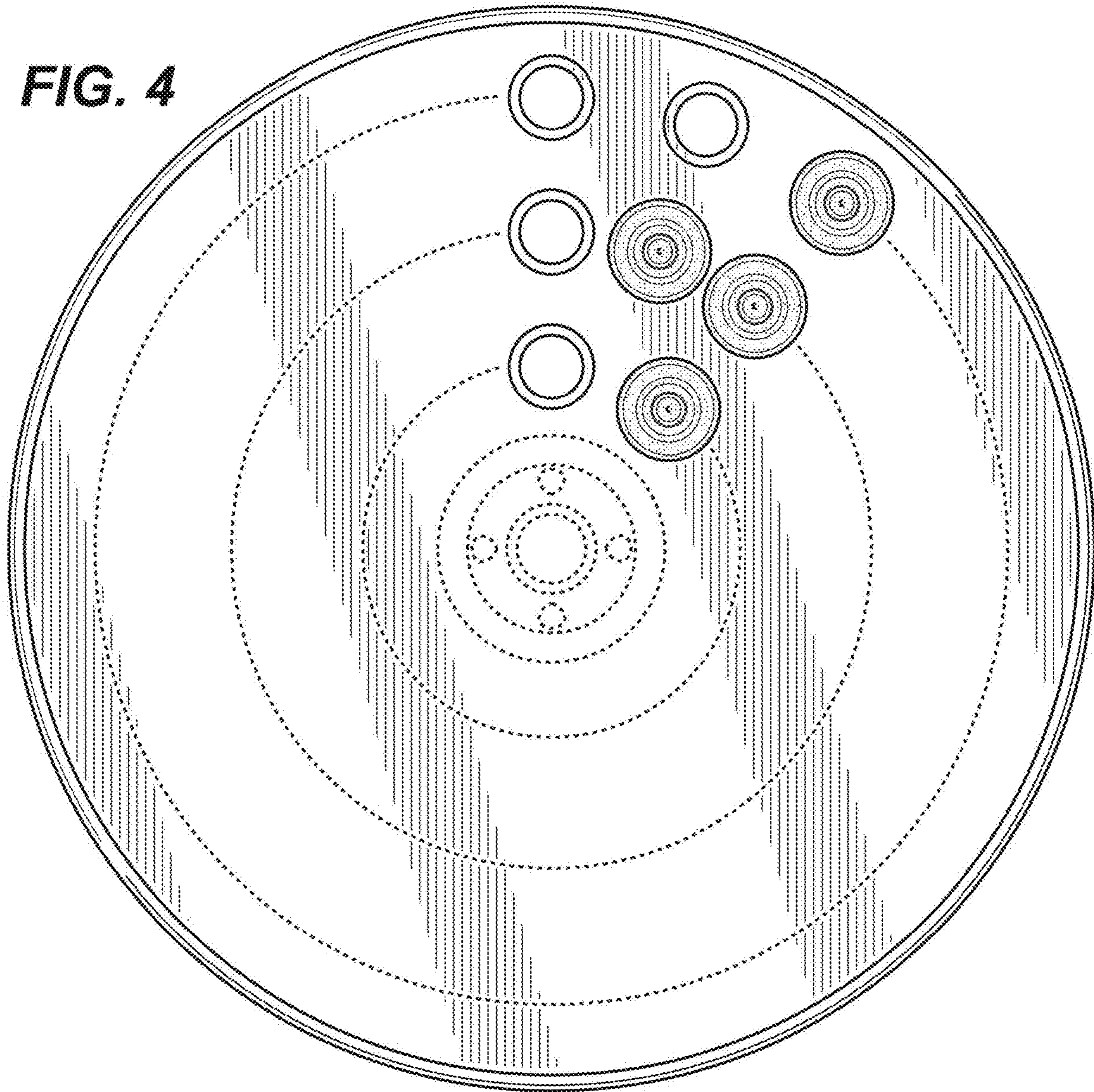

FIG. 3

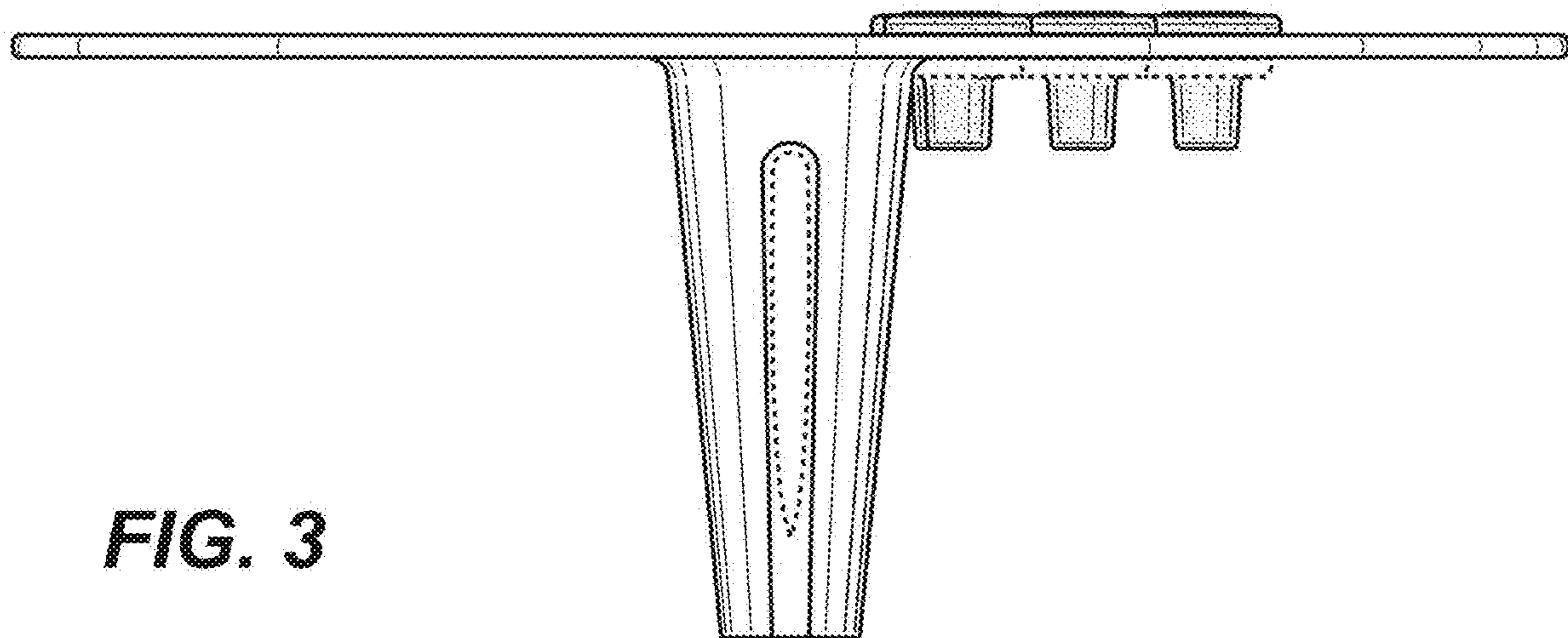

FIG. 5

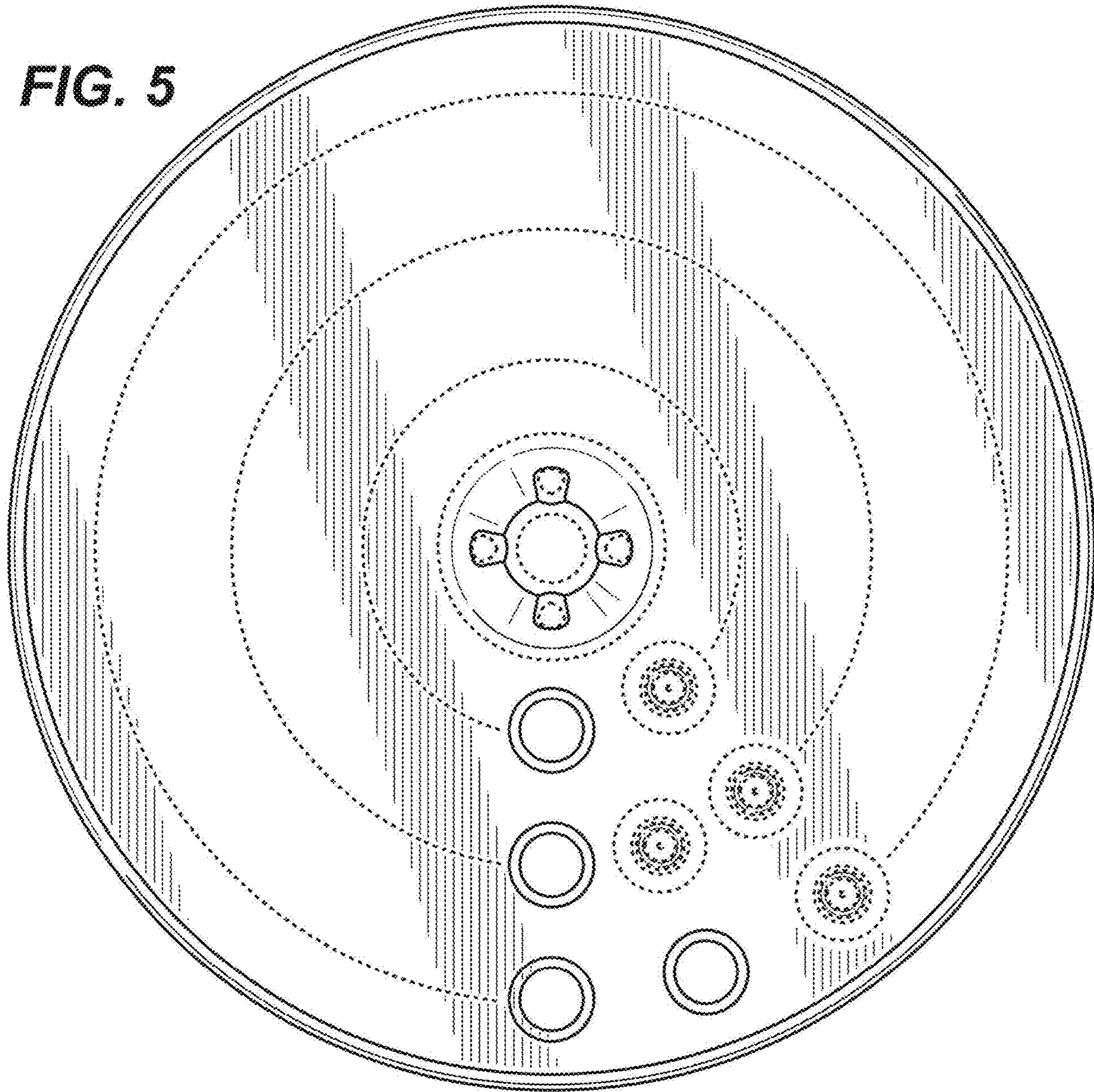

FIG. 6

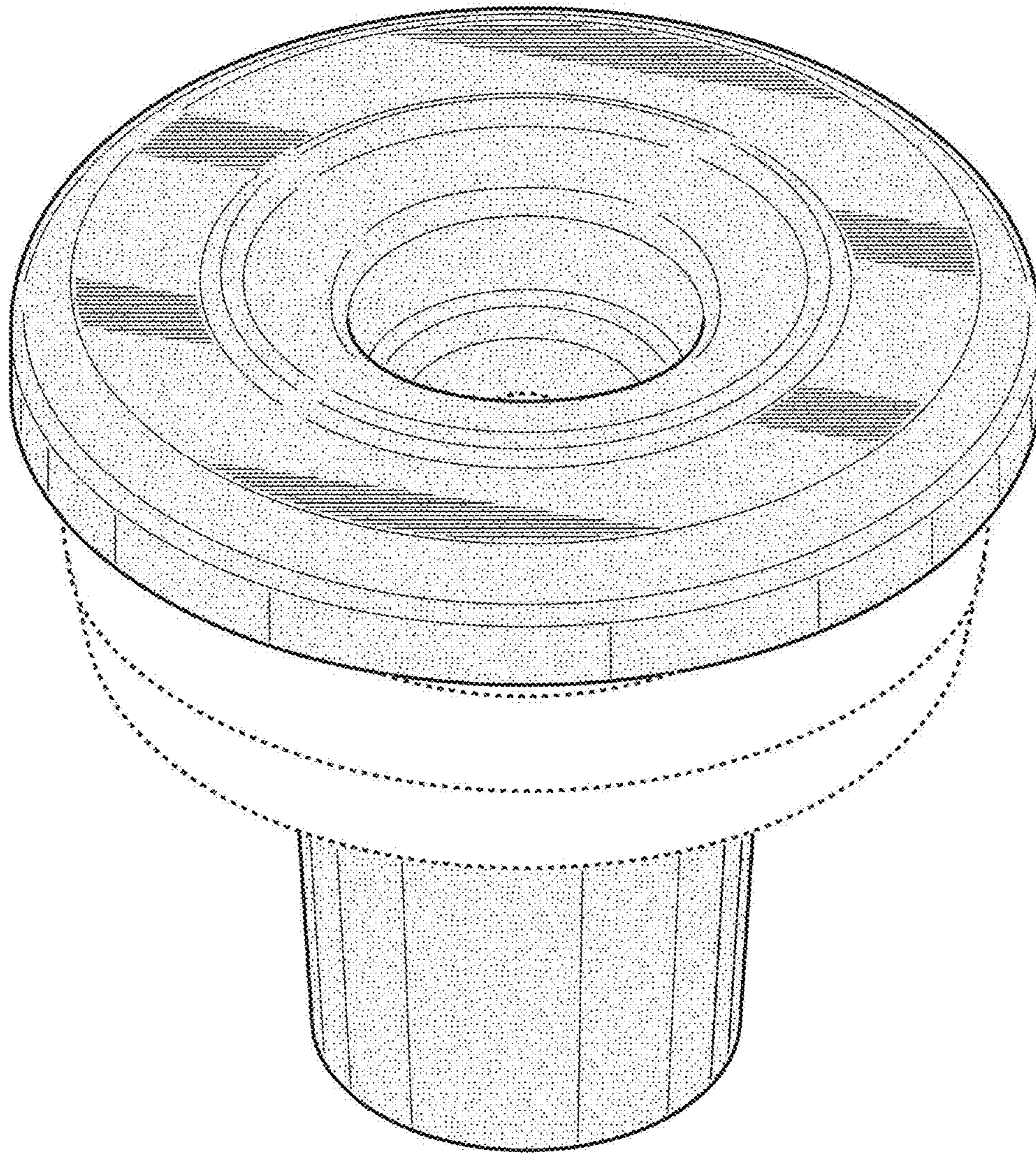

FIG. 7

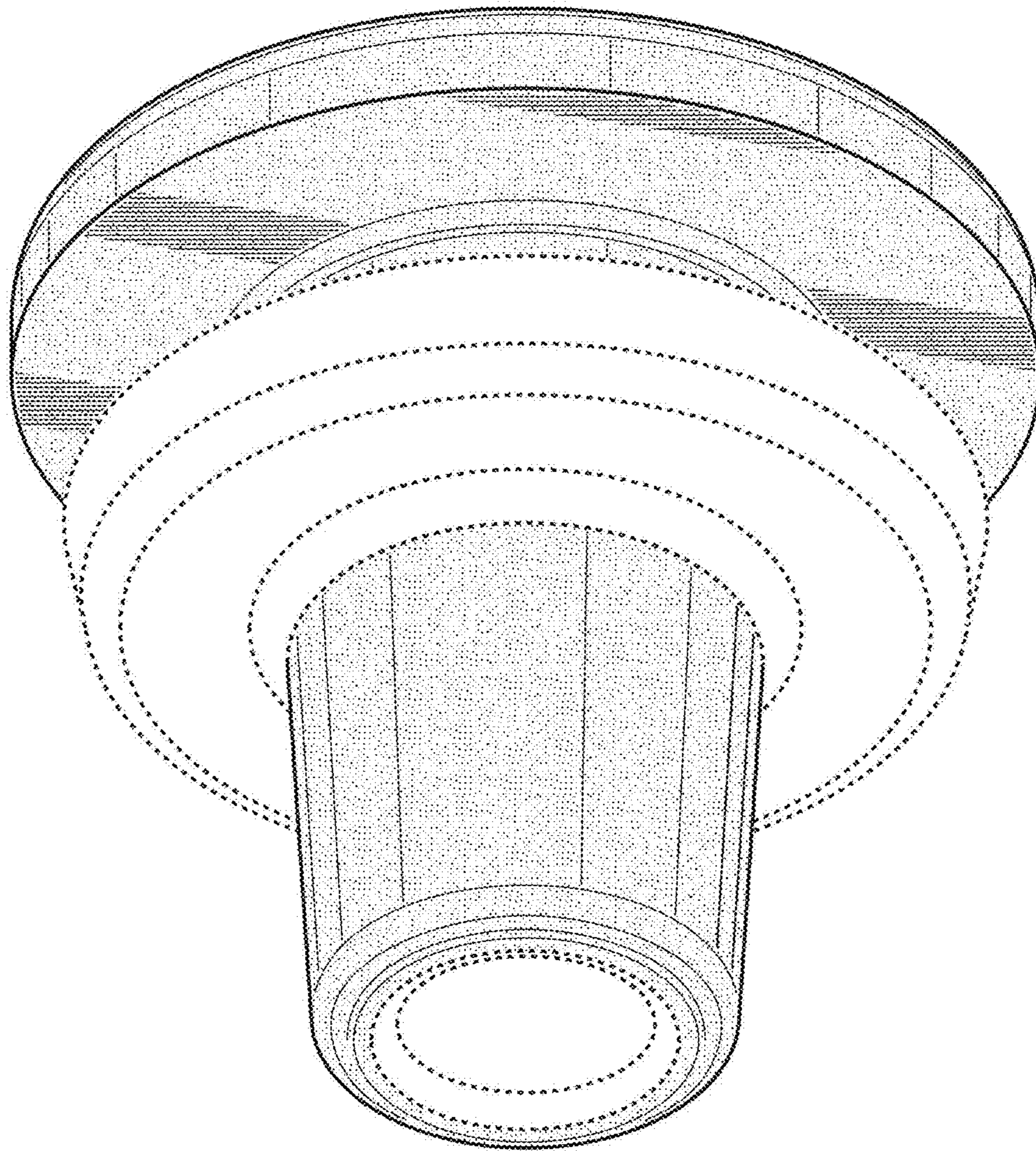
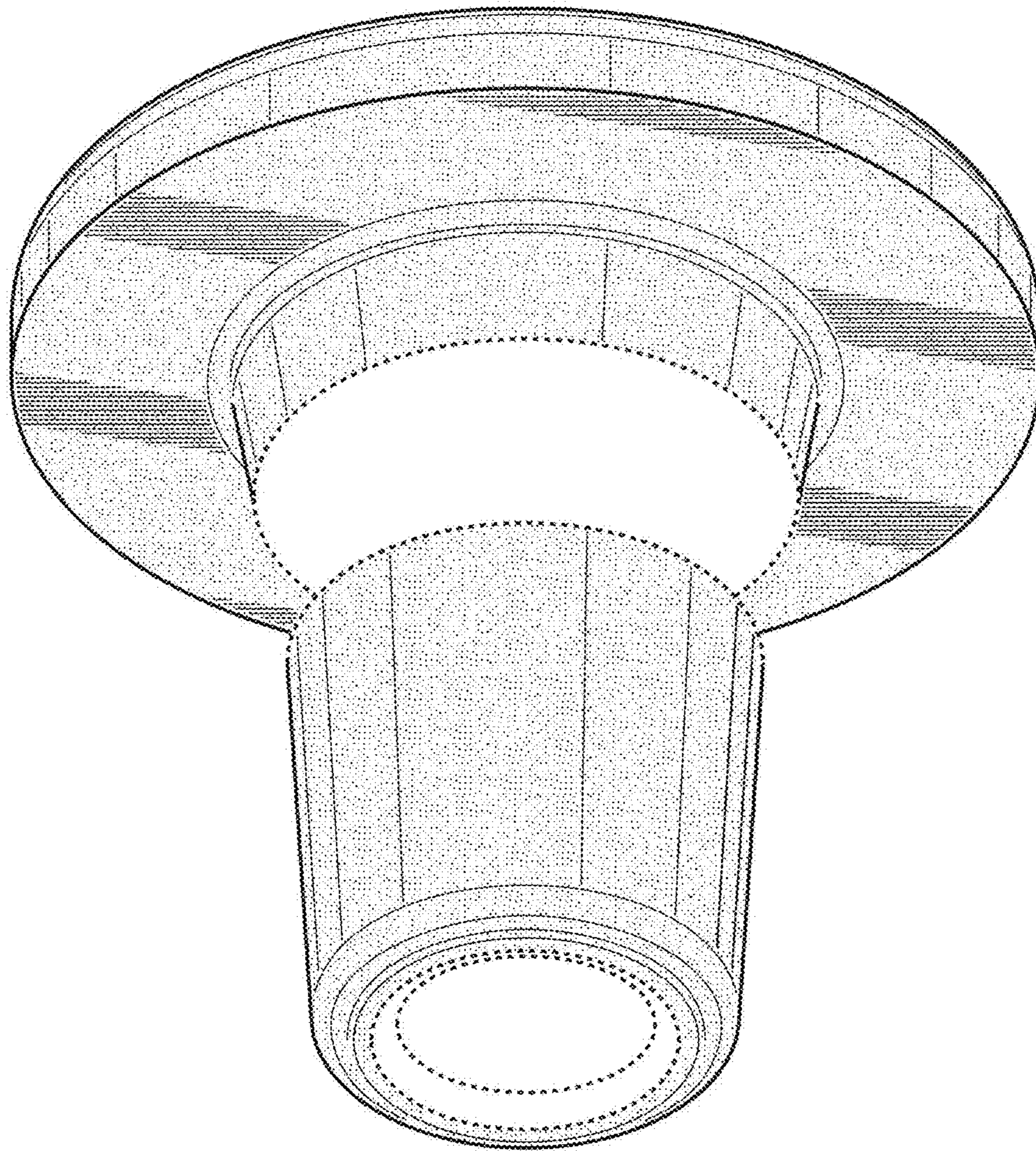

FIG. 8



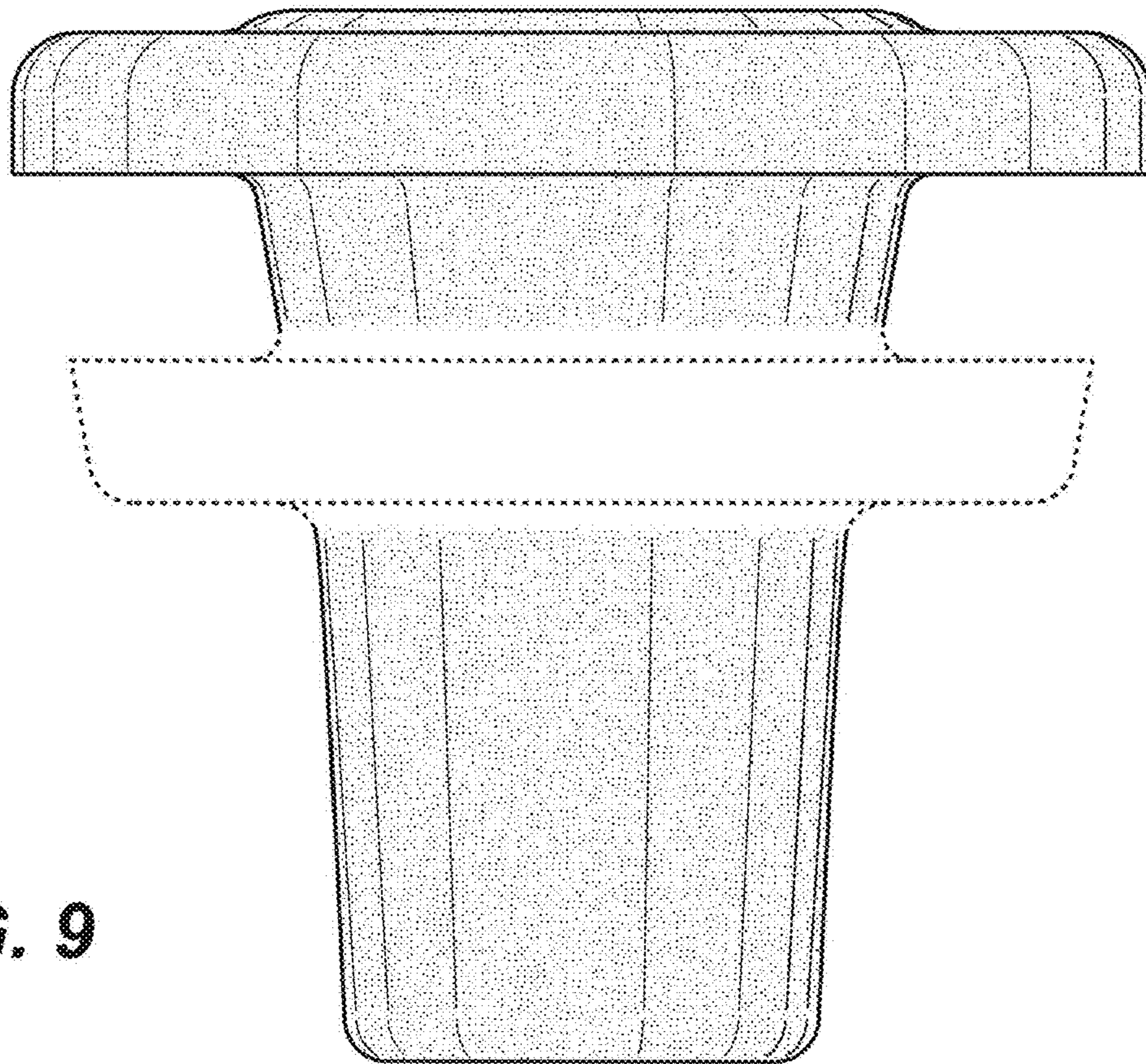

FIG. 9

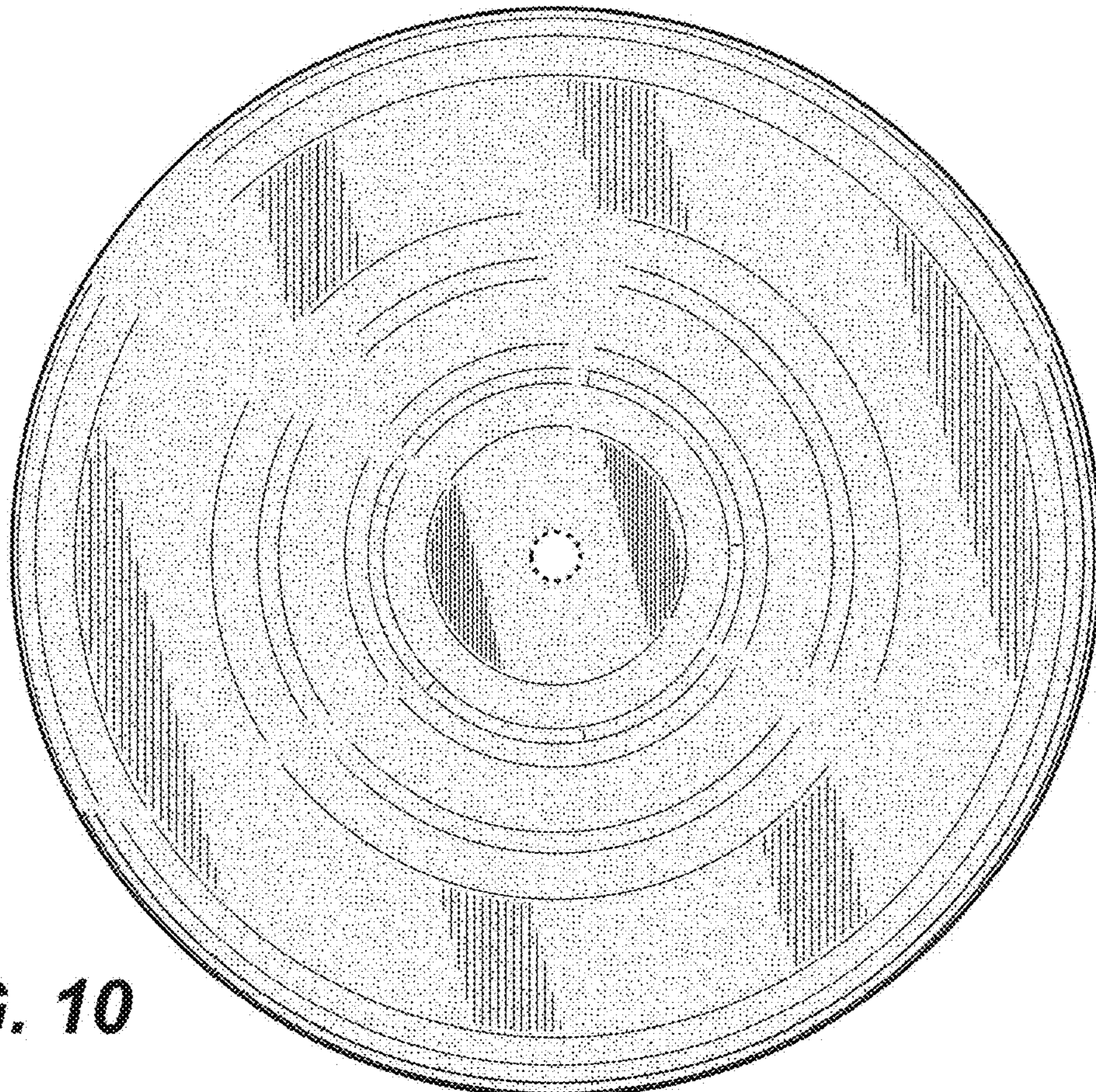

FIG. 10

FIG. 11

