



US00D907555S

(12) **United States Design Patent** (10) **Patent No.:** **US D907,555 S**  
**Kancuzewski et al.** (45) **Date of Patent:** **\*\* Jan. 12, 2021**

(54) **CARGO RESTRAINT STRAP**

FOREIGN PATENT DOCUMENTS

(71) Applicant: **LOGISTICK, INC.**, South Bend, IN (US)

GB 1209255 10/1970

(72) Inventors: **Nicholas Kancuzewski**, South Bend, IN (US); **John E. Townsend**, Paw Paw, IN (US); **Jason Ramtahal**, Berrien Springs, MI (US)

OTHER PUBLICATIONS

International Strap 2.0, www.logistick.com [online]. Published on Jun. 30, 2019, [retrieved on Sep. 25, 2020]. Retrieved from the Internet <URL:https://www.logistick.com/wp-content/uploads/2015/03/IS\_Instructions-Guide\_0619.pdf> (Year: 2019).\*

(73) Assignee: **LOGISTICK, INC.**, South Bend, IN (US)

(Continued)

(\*\*) Term: **15 Years**

*Primary Examiner* — Michael A. Pratt

*Assistant Examiner* — Adam C Mager

(21) Appl. No.: **29/702,526**

(74) *Attorney, Agent, or Firm* — Barnes & Thornburg LLP

(22) Filed: **Aug. 20, 2019**

(57) **CLAIM**

(51) **LOC (13) Cl.** ..... **12-16**

We claim the ornamental design for a cargo restraint strap, as shown and described.

(52) **U.S. Cl.**

USPC ..... **D12/223**

(58) **Field of Classification Search**

USPC ..... D12/223, 400, 406, 414; D8/349, 354, D8/382, 384

CPC ..... B60P 7/00; B60P 7/02; B60P 7/06; B60P 7/08; B60P 7/10; B60P 7/14; B60P 7/0807; B60P 7/0823; B60P 7/0853; B60P 7/0884

See application file for complete search history.

**DESCRIPTION**

FIG. 1 is a front perspective view of a cargo restraint strap in accordance with our new design;

FIG. 2 is a front elevation view of the cargo restraint strap of FIG. 1;

FIG. 3 is an enlarged view of the cargo restraint strap of FIG. 2;

FIG. 4 is a rear elevation view of the cargo restraint strap of FIG. 1;

FIG. 5 is a right-side elevation view of the cargo restraint strap of FIG. 1;

FIG. 6 is a left-side elevation view of the cargo restraint strap of FIG. 1;

FIG. 7 is a top plan view of the cargo restraint strap of FIG. 1; and,

FIG. 8 is a bottom plan view of the cargo restraint strap of FIG. 1.

The broken lines depict portions of the cargo restraint strap that form no part of the claimed design.

(56) **References Cited**

U.S. PATENT DOCUMENTS

969,002 A	8/1910	Teachout
1,238,874 A	9/1917	Biela
1,401,419 A	12/1921	McNally
1,951,660 A	3/1934	Klaudt
2,124,082 A	7/1938	Reifer
2,414,160 A	1/1947	Moon
2,464,080 A	3/1949	Hankins
2,467,681 A	4/1949	McKinney
2,468,101 A	4/1949	Nampa
2,468,104 A	4/1949	Phillips

(Continued)

**1 Claim, 6 Drawing Sheets**

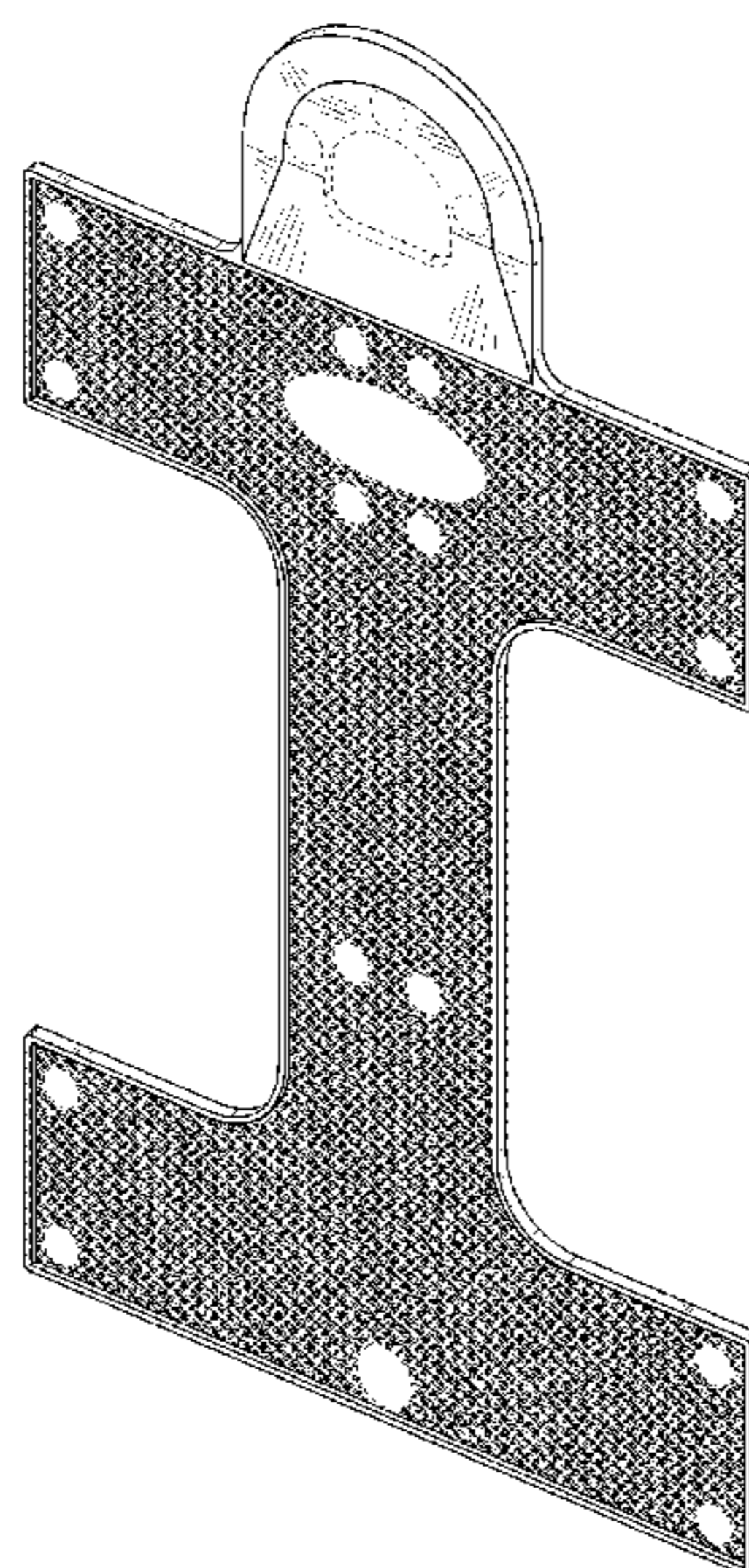

(56)

References Cited

U.S. PATENT DOCUMENTS

2,697,631 A 12/1954 Miller  
 2,752,864 A 7/1956 McDougal, Sr. et al.  
 2,766,704 A 10/1956 McMahan  
 2,845,245 A 5/1958 Gray et al.  
 2,905,107 A 9/1959 Nichol  
 2,912,939 A 11/1959 Miner, Jr. et al.  
 2,980,037 A 4/1961 Elsner  
 2,993,708 A 7/1961 Holman, Jr.  
 3,075,478 A 1/1963 Elsner  
 3,090,600 A 5/1963 Smith  
 3,177,007 A 4/1965 Oren  
 3,344,750 A 10/1967 Kostrewa  
 3,367,286 A 2/1968 Jantzen  
 3,559,591 A 2/1971 Breen et al.  
 3,590,746 A 7/1971 Gibson  
 D222,526 S \* 11/1971 Meier ..... D8/382  
 3,712,663 A 1/1973 Laven  
 D232,821 S 9/1974 Fry  
 3,836,174 A 9/1974 Holman, Jr.  
 3,995,565 A 12/1976 Kersey  
 4,026,508 A 5/1977 Ziegler  
 4,080,906 A 3/1978 Brown  
 D248,228 S 6/1978 Robertson  
 4,264,251 A 4/1981 Blatt  
 4,278,376 A 7/1981 Hunter  
 4,396,325 A 8/1983 Joice-Cavanagh  
 4,432,678 A 2/1984 Liebel  
 4,473,225 A 9/1984 Miller  
 4,498,824 A 2/1985 Kinkle  
 4,616,757 A 10/1986 Hobson  
 4,700,918 A 10/1987 Andrasko, Jr.  
 4,718,584 A 1/1988 Schoeny  
 D294,340 S 2/1988 Robson  
 4,735,468 A 4/1988 Taylor, Jr. et al.  
 4,756,498 A 7/1988 Frye  
 4,801,228 A 1/1989 Van Gompel  
 4,830,558 A 5/1989 Sweeney  
 4,846,610 A 7/1989 Schoenleben  
 4,880,342 A 11/1989 Pradovic  
 4,932,817 A 6/1990 Mattare  
 4,955,771 A 9/1990 Bott  
 4,962,907 A 10/1990 Gary  
 D312,604 S 12/1990 Barnes et al.  
 4,982,922 A 1/1991 Krause  
 5,028,184 A 7/1991 Krause  
 5,037,256 A 8/1991 Schroeder  
 D324,303 S 3/1992 Miller  
 5,156,110 A 10/1992 Fuller  
 5,161,700 A 11/1992 Stannis et al.  
 5,169,007 A 12/1992 McHendry  
 D332,242 S 1/1993 Graehling  
 5,219,251 A 6/1993 Kancuzewski  
 D339,682 S 9/1993 Phelps  
 5,259,712 A 11/1993 Wayne  
 5,281,063 A 1/1994 Austin, III  
 D344,482 S 2/1994 Arvidsson  
 D347,419 S 5/1994 Jackson  
 5,320,464 A 6/1994 Long et al.  
 5,326,204 A 7/1994 Carlson et al.  
 5,362,184 A 11/1994 Hull et al.  
 5,370,482 A 12/1994 Long  
 5,392,972 A 2/1995 Caruso et al.  
 D358,125 S 5/1995 Jackson  
 5,494,389 A 2/1996 Kancuzewski  
 5,526,972 A 6/1996 Frazier et al.  
 D372,016 S 7/1996 Wolford  
 D373,754 S 9/1996 Pinterpe  
 D376,578 S 12/1996 Redford  
 5,636,951 A 6/1997 Long et al.  
 D382,533 S 8/1997 Okland  
 5,688,087 A 11/1997 Stapleton et al.  
 D392,246 S 3/1998 Anderson  
 D395,998 S 7/1998 Ballinger

D397,322 S 8/1998 Tobin  
 5,807,047 A 9/1998 Cox  
 D406,095 S 2/1999 Denny et al.  
 D412,151 S 7/1999 Ferrigan  
 D422,554 S 4/2000 Stapleton et al.  
 6,068,228 A 5/2000 Kobayashi et al.  
 D426,512 S 6/2000 Ciuba  
 6,074,143 A 6/2000 Langston et al.  
 6,086,299 A 7/2000 Kancuzewski  
 6,106,205 A 8/2000 Haire  
 D434,369 S 11/2000 Matthies  
 D438,022 S 2/2001 Bunn  
 D450,291 S 11/2001 Wang  
 D453,869 S 2/2002 Schultz et al.  
 D458,210 S 6/2002 Kancuzewski et al.  
 6,419,434 B1 7/2002 Rahn  
 6,431,804 B1 8/2002 Wetzig, III  
 D462,310 S \* 9/2002 Kancuzewski ..... D12/223  
 6,454,501 B1 9/2002 Parker  
 6,533,513 B2 3/2003 Kancuzewski et al.  
 6,572,063 B1 6/2003 Gitelman et al.  
 D478,857 S \* 8/2003 Petersen ..... D12/223  
 6,607,338 B2 8/2003 Lemke  
 6,851,652 B1 2/2005 Huang  
 6,874,982 B2 4/2005 Rhodes  
 D506,076 S 6/2005 Weisgerber  
 6,942,004 B2 9/2005 Whitemore  
 7,037,055 B1 5/2006 Rogers et al.  
 7,134,820 B2 11/2006 Ehrlich  
 D537,405 S 2/2007 Saward  
 7,334,973 B2 2/2008 Scott  
 7,356,888 B2 4/2008 Chao et al.  
 D571,279 S 6/2008 Trusty et al.  
 D589,709 S 4/2009 Edwards  
 7,628,572 B2 12/2009 Kancuzewski et al.  
 7,713,008 B2 5/2010 Kancuzewski et al.  
 7,785,051 B2 8/2010 Kancuzewski et al.  
 7,785,052 B2 8/2010 Kancuzewski et al.  
 7,817,922 B2 10/2010 Cho et al.  
 D633,030 S 2/2011 Robertson  
 D638,345 S 5/2011 Kancuzewski et al.  
 8,192,121 B1 6/2012 Kancuzewski et al.  
 8,425,166 B2 4/2013 Kancuzewski et al.  
 8,545,150 B2 10/2013 Kancuzewski et al.  
 8,545,151 B2 10/2013 Kancuzewski et al.  
 8,550,758 B2 10/2013 Kancuzewski et al.  
 8,696,273 B1 4/2014 Kancuzewski et al.  
 D722,004 S \* 2/2015 Kancuzewski ..... D12/223  
 9,234,537 B2 1/2016 Huang  
 9,550,446 B1 1/2017 Kancuzewski et al.  
 9,764,679 B2 9/2017 Kancuzewski et al.  
 9,821,701 B2 11/2017 Kancuzewski et al.  
 2002/0071733 A1 6/2002 Parker  
 2002/0176759 A1 11/2002 Kancuzewski  
 2004/0156692 A1 8/2004 Rhodes  
 2007/0224010 A1 9/2007 Cunningham  
 2008/0152455 A1 6/2008 Kancuzewski  
 2010/0111636 A1 5/2010 Widynowski  
 2010/0308091 A1 12/2010 Hubbard  
 2011/0068137 A1 3/2011 Murray et al.  
 2015/0158411 A1 6/2015 Pakulak  
 2018/0334077 A1 \* 11/2018 Suppinger ..... B21D 47/00  
 2019/0366907 A1 12/2019 Kancuzewski  
 2019/0367267 A1 12/2019 Kancuzewski

OTHER PUBLICATIONS

“Complete Installation Guide for the International Strap . . . The One-Way Solution for Securing Lightweight, Regular—or Irregular—shaped Loads in International Shipping Containers”, Logistick, Innovators of Freight Securement Systems 2 pages. (available prior to Aug. 20, 2019).  
 Logistick Disposable Cargo Strap Advertisement (2000).

\* cited by examiner

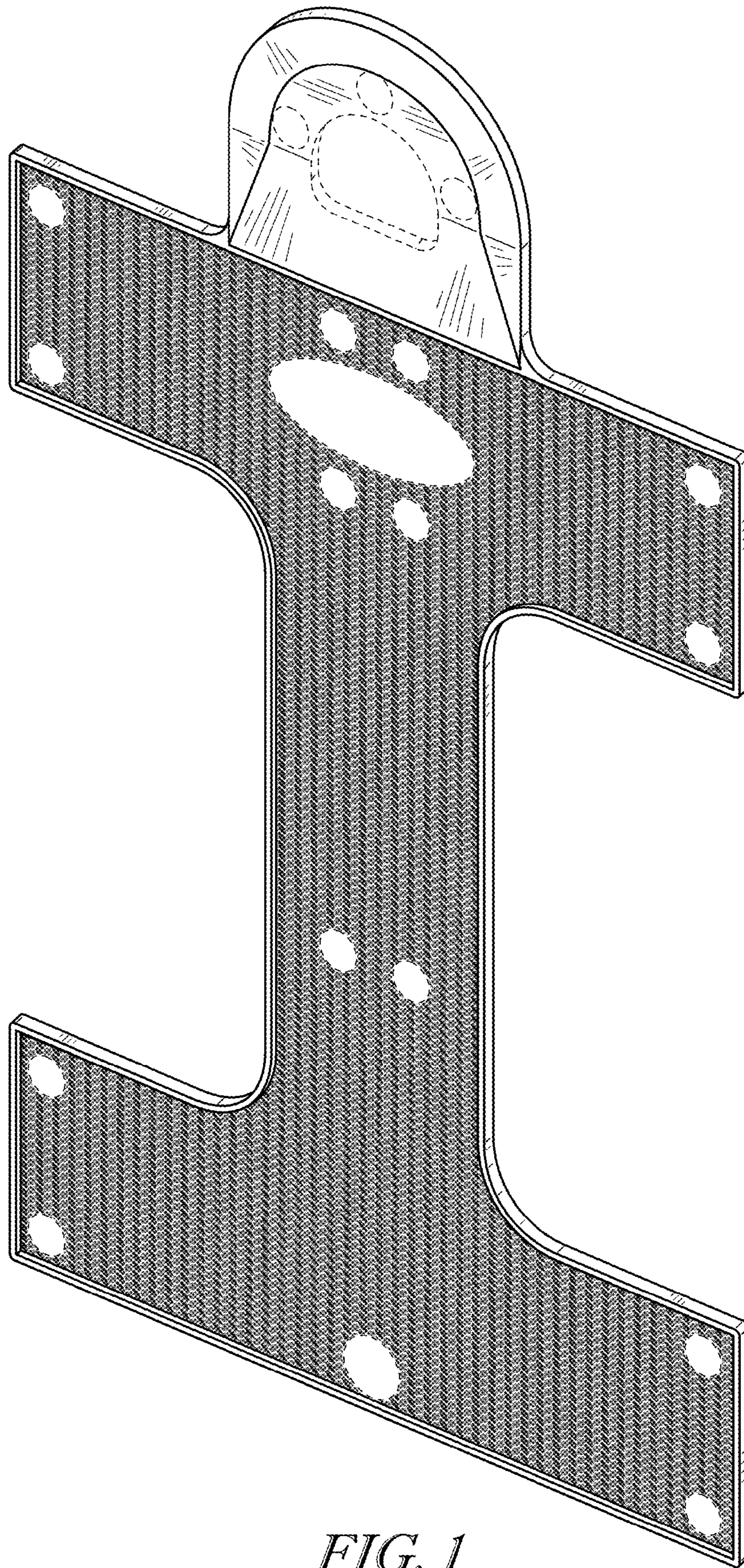

*FIG. 1*

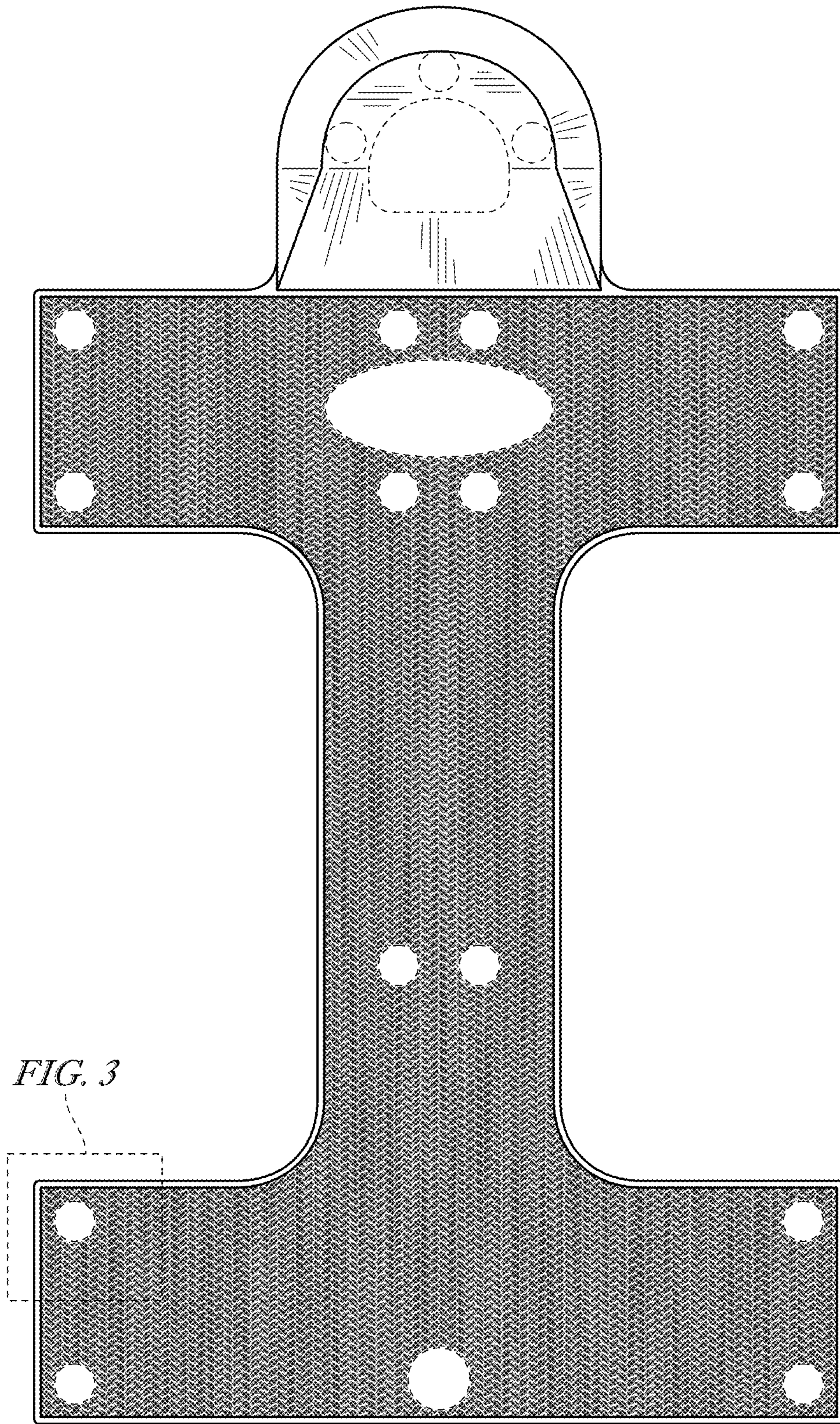
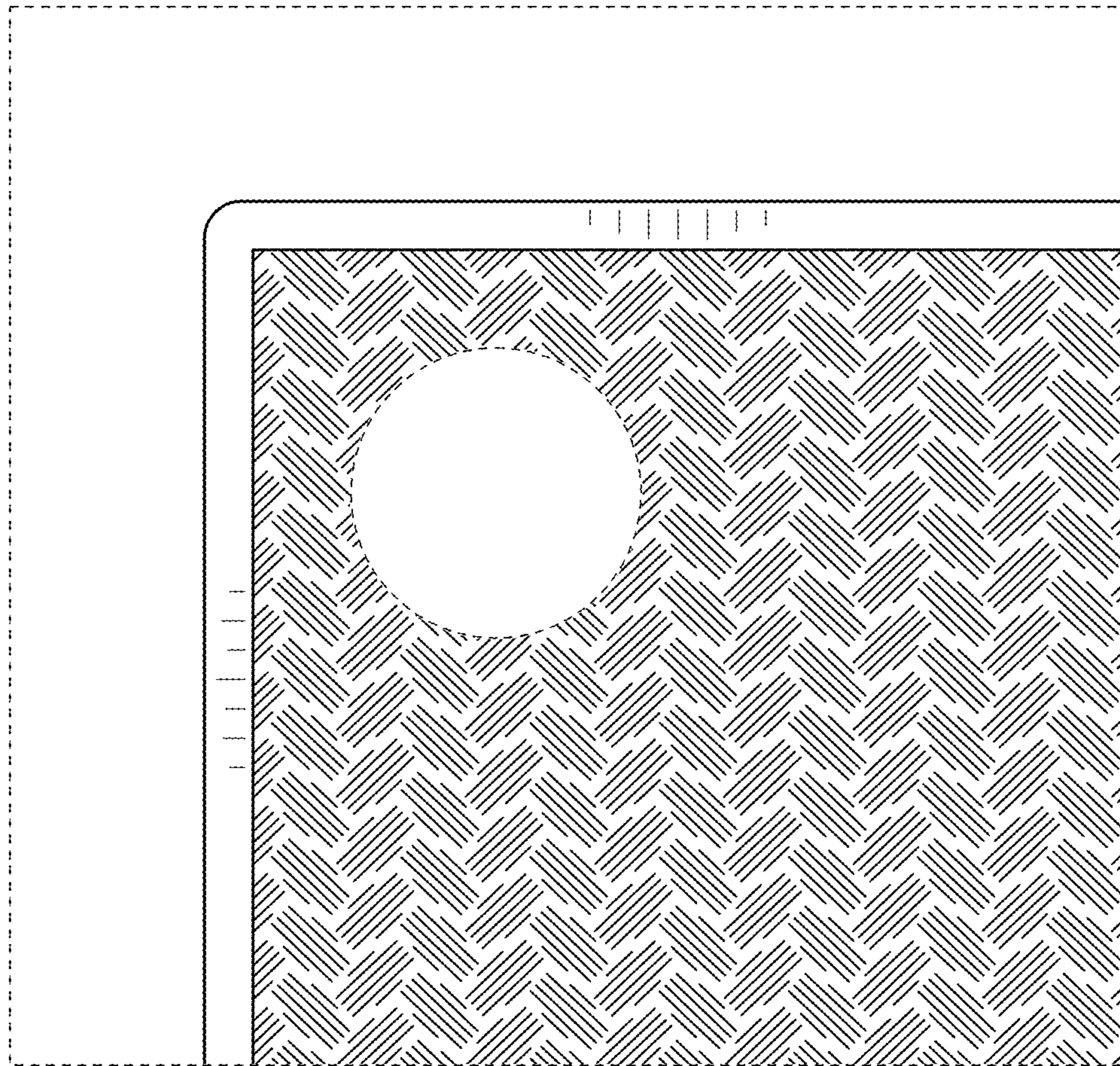
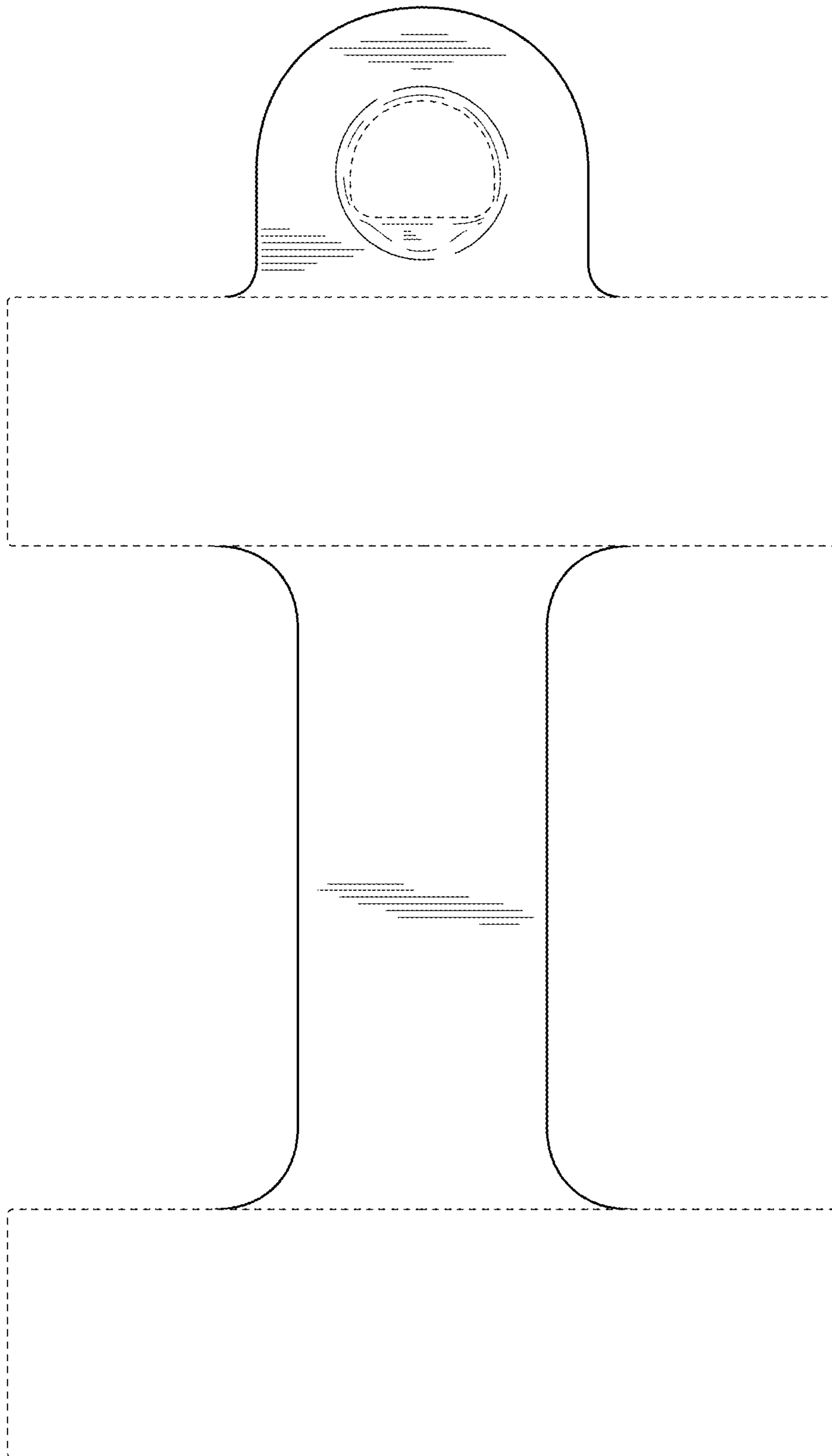

FIG. 2



*FIG. 3*



*FIG. 4*



*FIG. 5*



*FIG. 6*

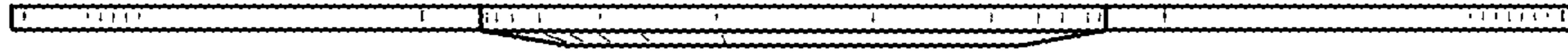

*FIG. 7*

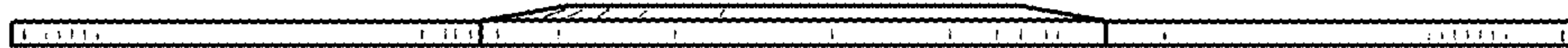

*FIG. 8*