

US00D907063S

(12) **United States Design Patent**
Wettig

(10) **Patent No.:** **US D907,063 S**
(45) **Date of Patent:** **** Jan. 5, 2021**

(54) **AIR TO WATER INTERCOOLER FOR
AUTOMOTIVE APPLICATIONS**

(71) Applicant: **RESOURCE INTERNATIONAL
INC.**, New Castle, DE (US)

(72) Inventor: **Jason Wettig**, Abingdon, MD (US)

(**) Term: **15 Years**

(21) Appl. No.: **29/664,743**

(22) Filed: **Sep. 27, 2018**

(51) **LOC (13) Cl.** **15-01**

(52) **U.S. Cl.**
USPC **D15/5**

(58) **Field of Classification Search**
USPC D15/5; D12/163-166, 218, 216
CPC F28F 9/001; F28F 9/007; F28F 7/00; F28F
9/00; F28F 9/02; F28D 1/05366; F28D
1/0435; F01P 2060/02; F01P 2060/14;
F01P 2003/022

See application file for complete search history.

(56) **References Cited**

U.S. PATENT DOCUMENTS

D246,977 S *	1/1978	Campbell	D12/218
5,547,019 A *	8/1996	Iacullo	H01L 35/30 165/51
D890,674 S *	7/2020	Tafe	D12/218
D892,971 S *	8/2020	Wettig	D23/202
2007/0251232 A1 *	11/2007	de Kok	F28F 7/02 60/599
2012/0291993 A1 *	11/2012	Concialdi	F28D 9/0062 165/104.11
2017/0097194 A1 *	4/2017	Klaves	F28D 7/024
2017/0146305 A1 *	5/2017	Kuczek	F28F 9/0256
2017/0335746 A1 *	11/2017	Somhorst	F28F 9/0226
2018/0087847 A1 *	3/2018	Bangert	F28F 9/0241
2019/0309675 A1 *	10/2019	Nishiyama	F28D 9/0056
2019/0331266 A1 *	10/2019	Kang	F01P 11/12

OTHER PUBLICATIONS

Mishimoto, Ford 6.7L Powerstroke Air-to-Water Performance Inter-cooler, 2011-2016, (site visited Aug. 27, 2020), Mishimoto.com, URL:<<https://www.mishimoto.com/ford-powerstroke-2011-2016-671-intercooler.html>> (Year: 2020).*

(Continued)

Primary Examiner — Sheryl Lane

Assistant Examiner — Mark T. Philipps

(74) *Attorney, Agent, or Firm* — Cozen O'Connor

(57) **CLAIM**

The ornamental design for an air to water intercooler for automotive applications, as shown and described.

DESCRIPTION

FIG. 1 is a front view of an air to water intercooler for automotive applications showing our new design;
FIG. 2 is a back view thereof;
FIG. 3 is a top view thereof;
FIG. 4 is an enlarged view of the area identified as “4” in FIG. 3;
FIG. 5 is an enlarged view of the area identified as “5” in FIG. 3;
FIG. 6 is a bottom view of the air to water intercooler for automotive applications;
FIG. 7 is a left view thereof;
FIG. 8 is right view thereof;
FIG. 9 is a perspective view thereof; and,
FIG. 10 is another perspective view thereof.
The broken lines in the drawing figures show portions of the air to water intercooler for automotive applications which form no part of the claimed design.
The shade lines in the figures show contour and not surface ornamentation.

1 Claim, 10 Drawing Sheets

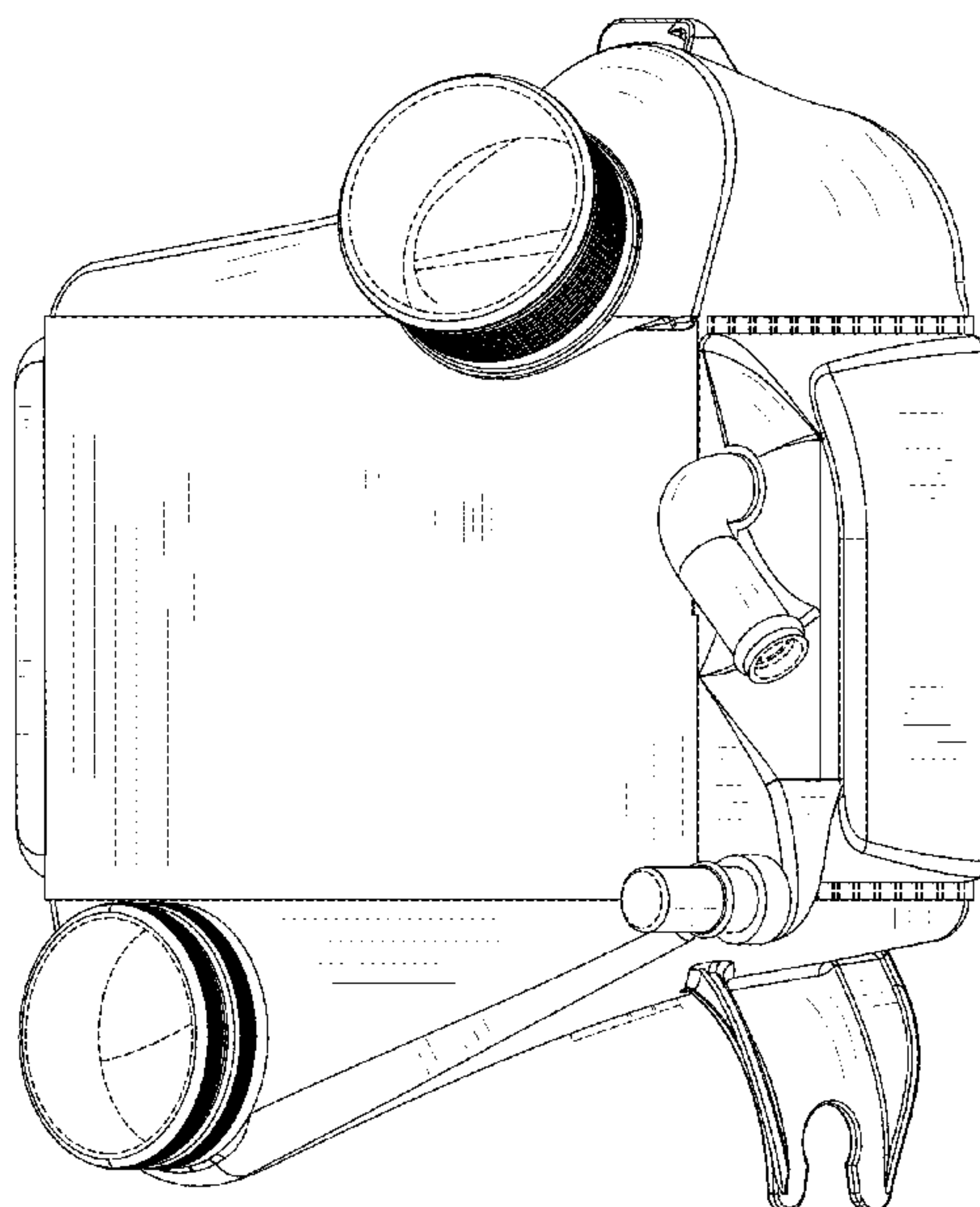

(56)

References Cited

OTHER PUBLICATIONS

Ford, BC3Z-6K775-B Air to Water Intercooler Assy 2011-2016 Ford 6.7L, (site visited Aug. 27, 2020), Perfdiesel.com, URL :<<https://www.perfdiesel.com/home/4583-bc3z-6k775-b-air-to-water-intercooler-assy-2011-2016-ford-671.html>> (Year: 2020).*

No Limit, 17-19 6.7 Intercooler Air to Water Kit Polished, (site visited Aug. 27, 2020), Thoroughbred Diesel, URL: 21 <https://www.thoroughbreddiesel.com/products/performance/intercoolers/intercooler/>> (Year: 2020).*

* cited by examiner

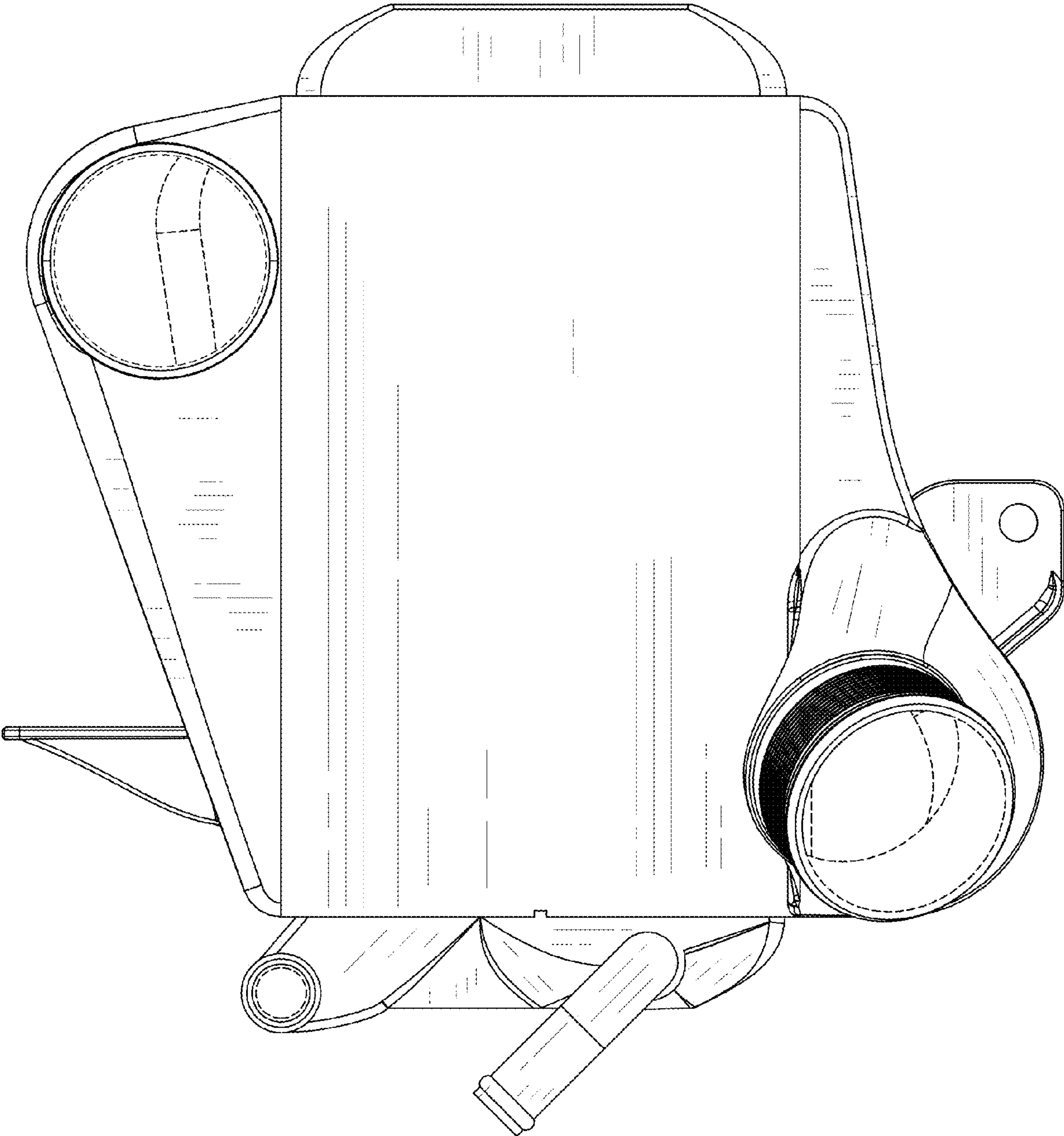

FIGURE 1

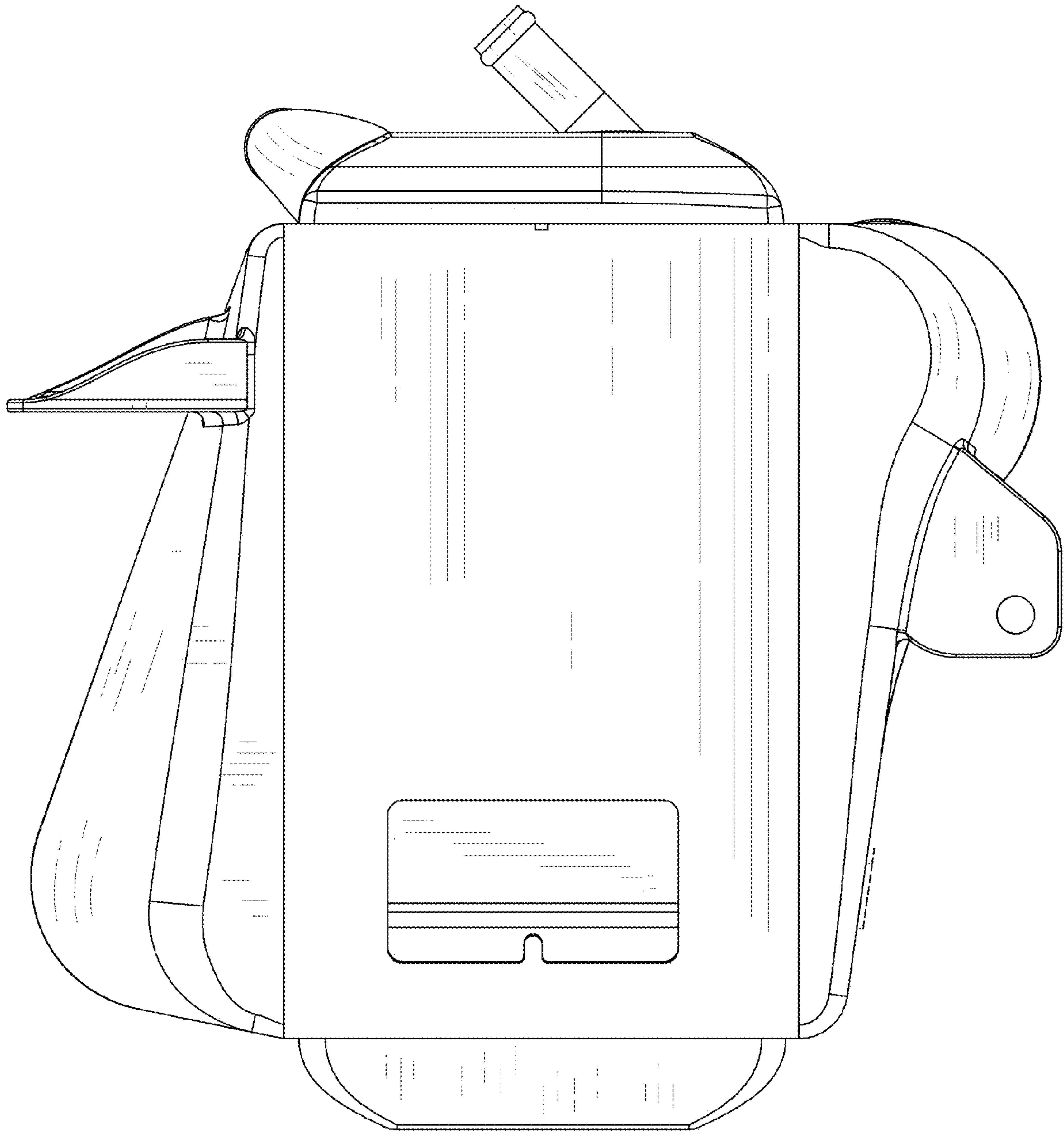

FIGURE 2

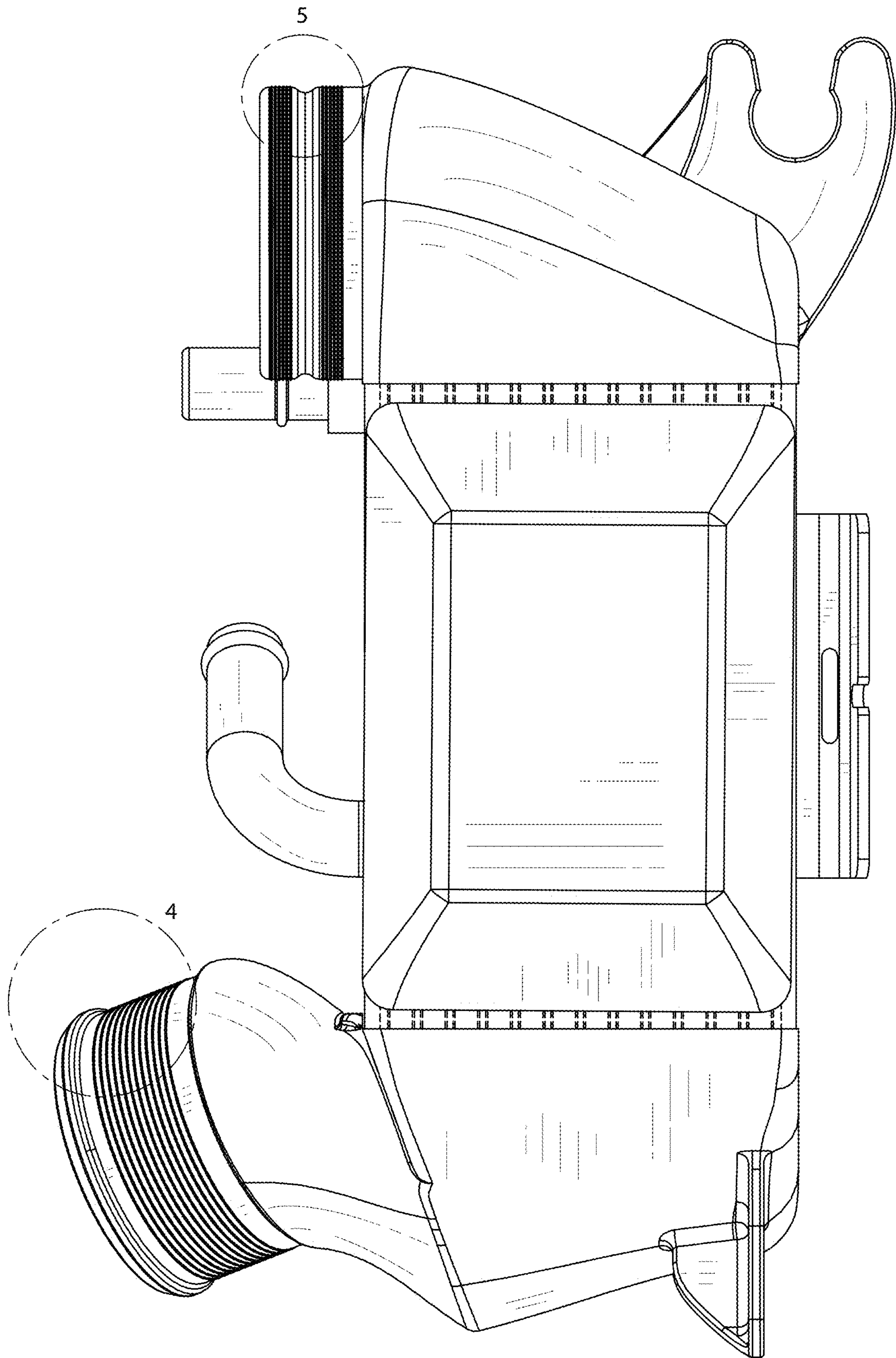

FIGURE 3

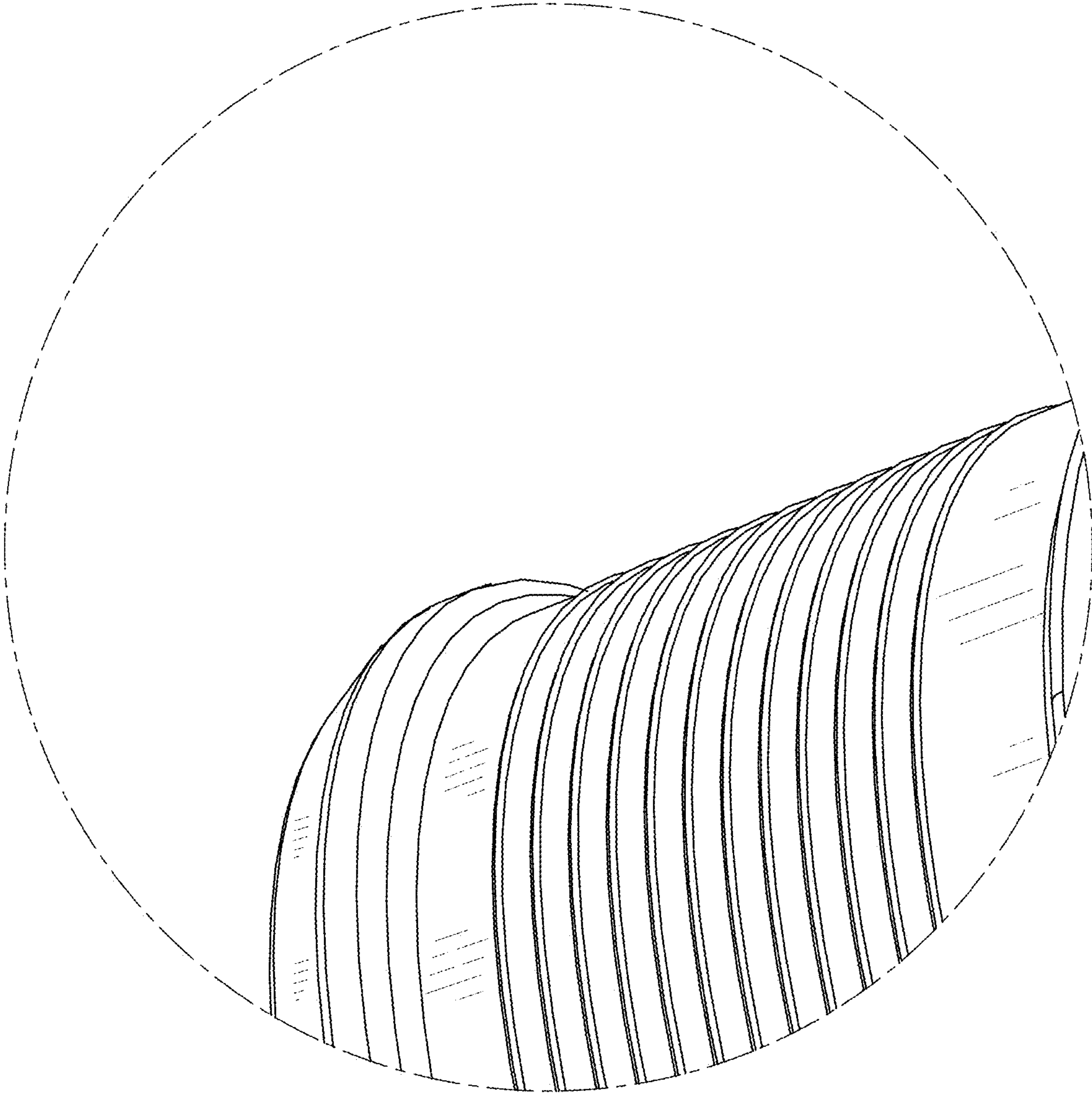

FIGURE 4

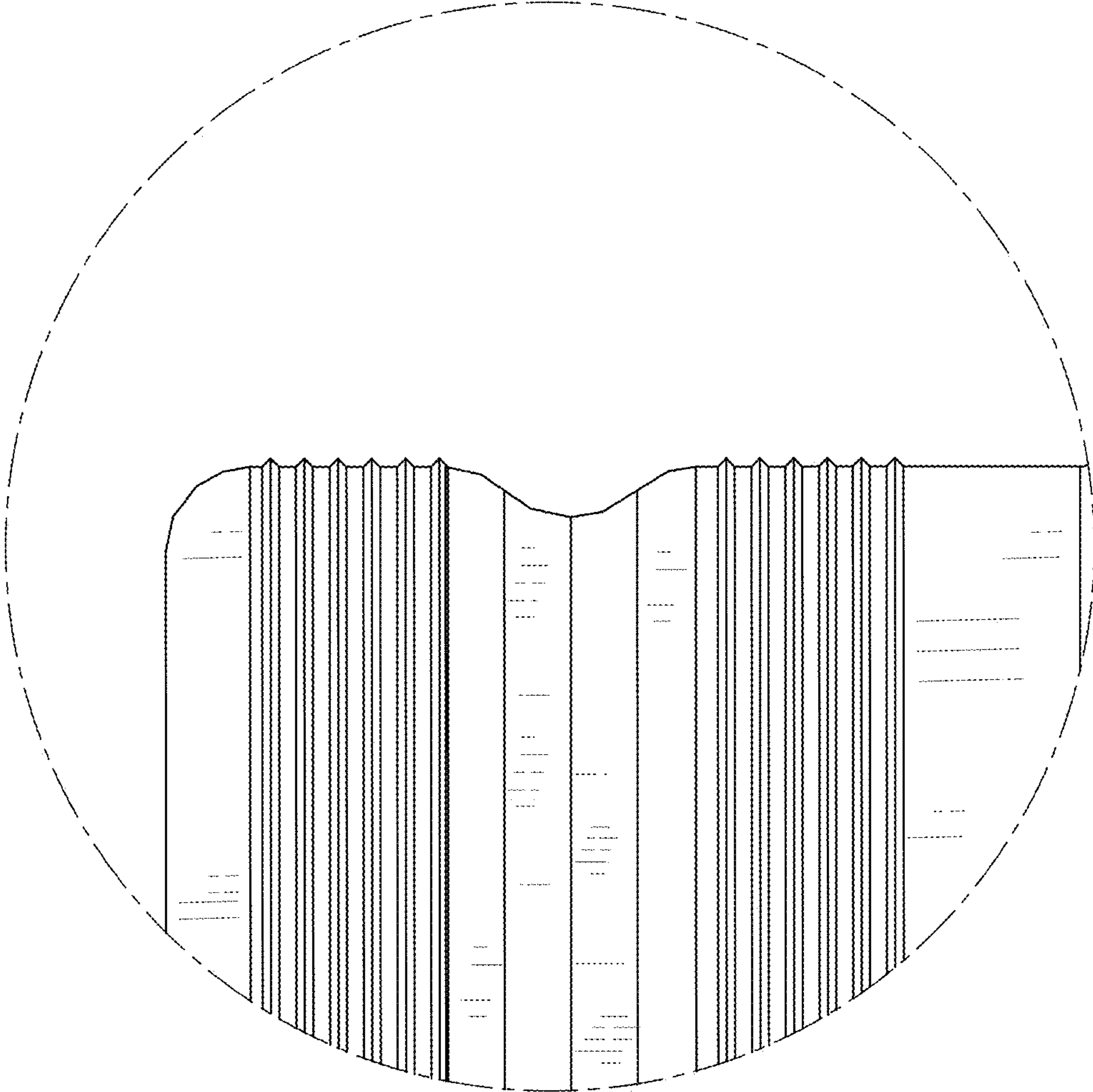

FIGURE 5

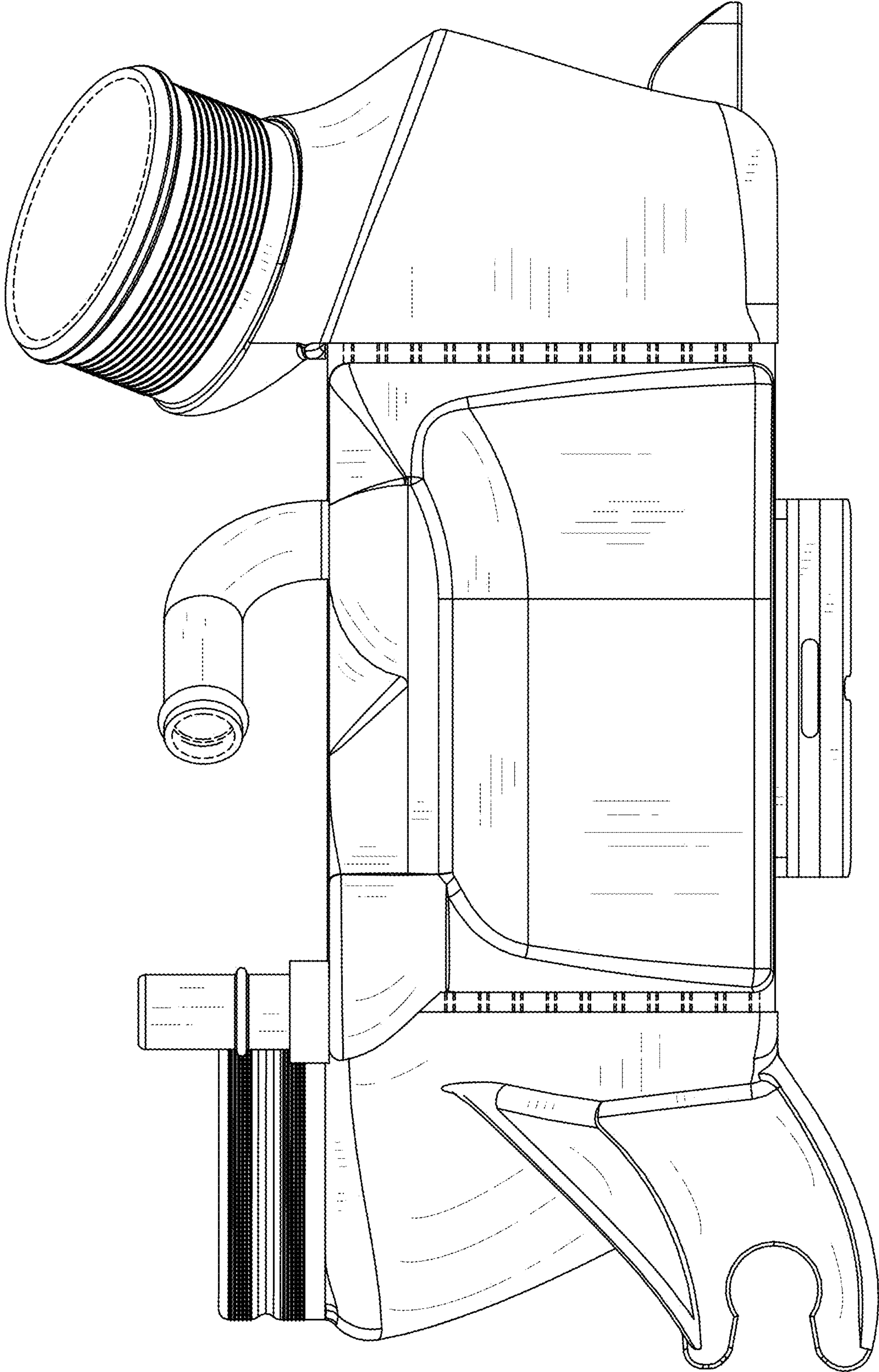

FIGURE 6

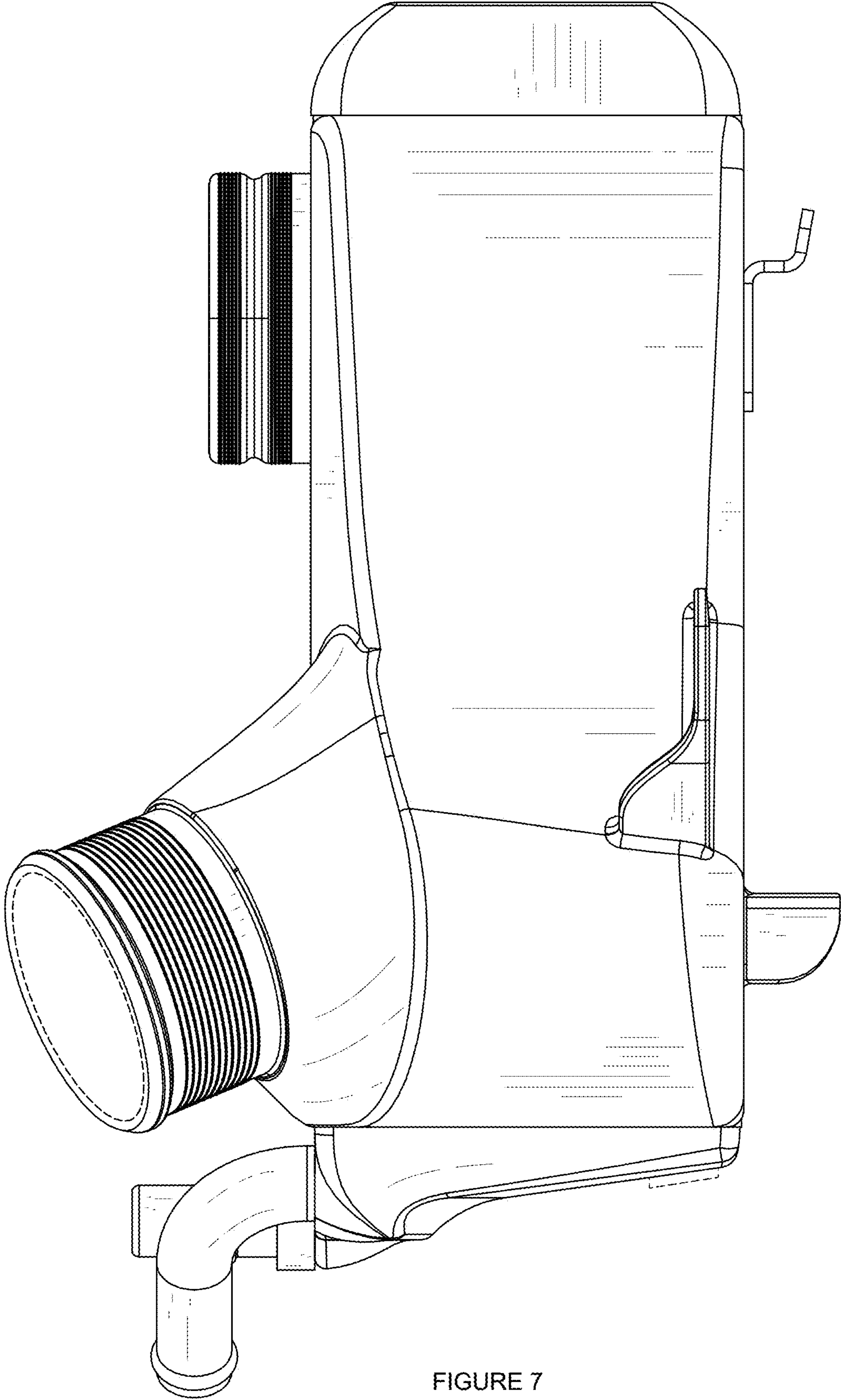

FIGURE 7

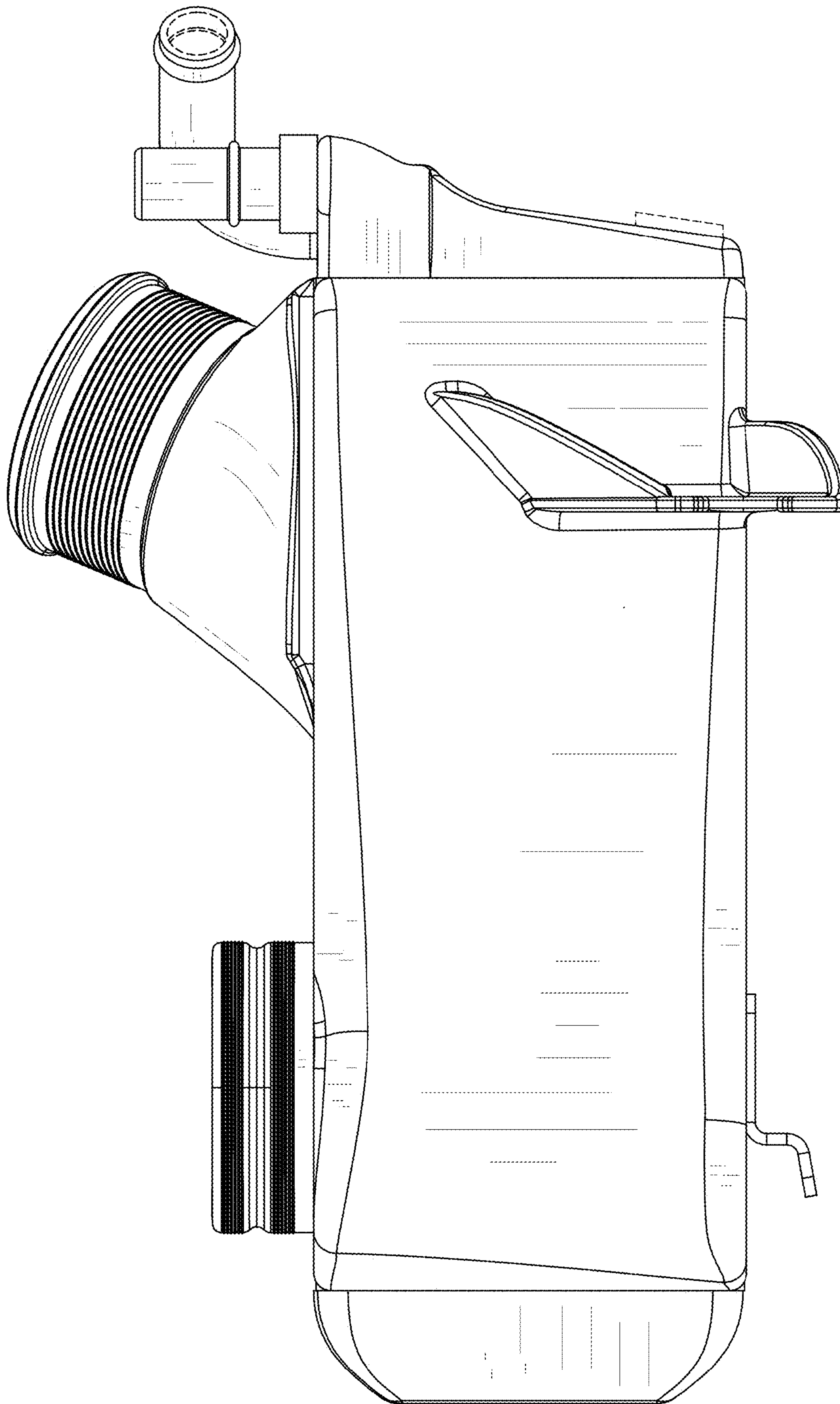

FIGURE 8

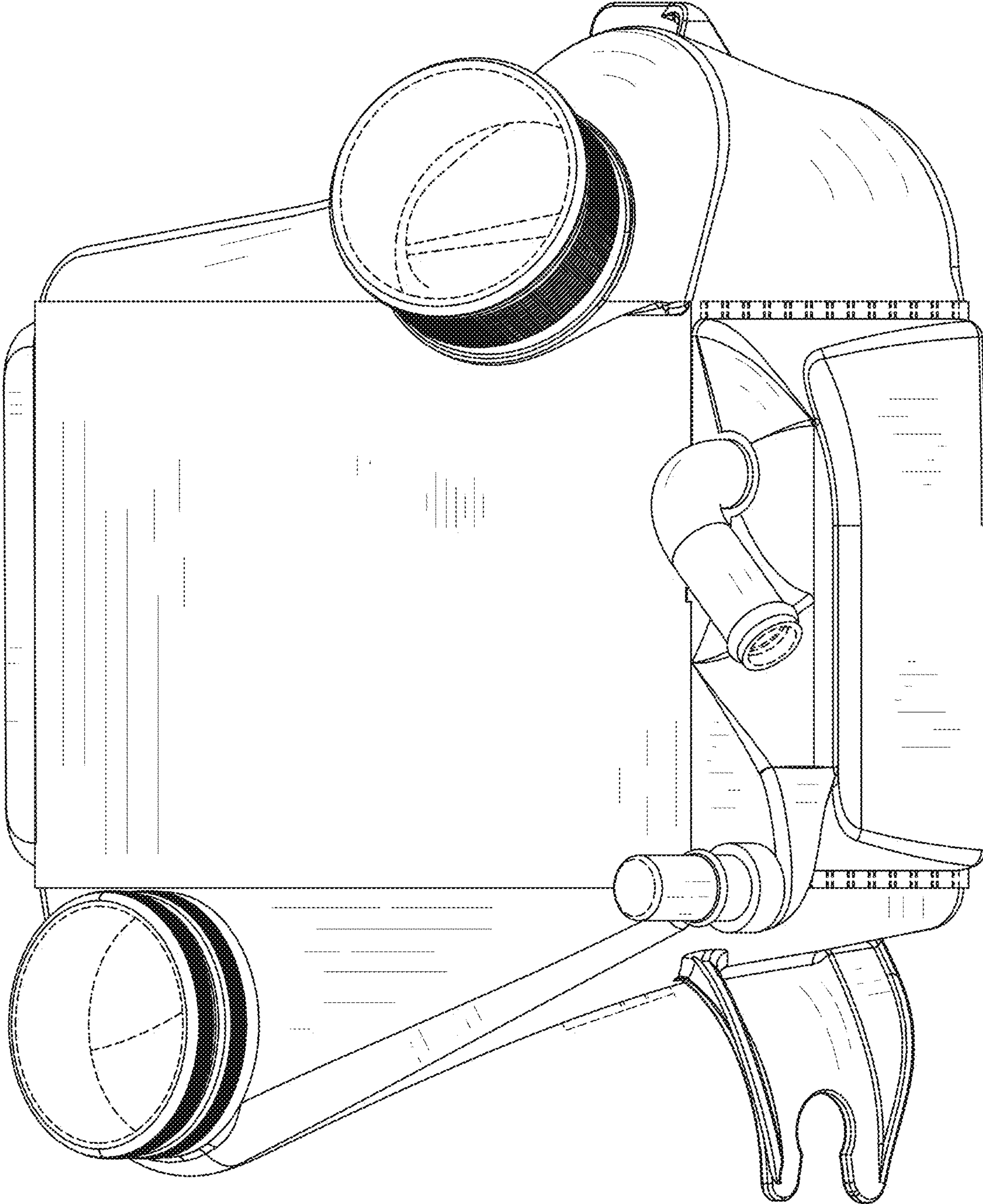

FIGURE 9

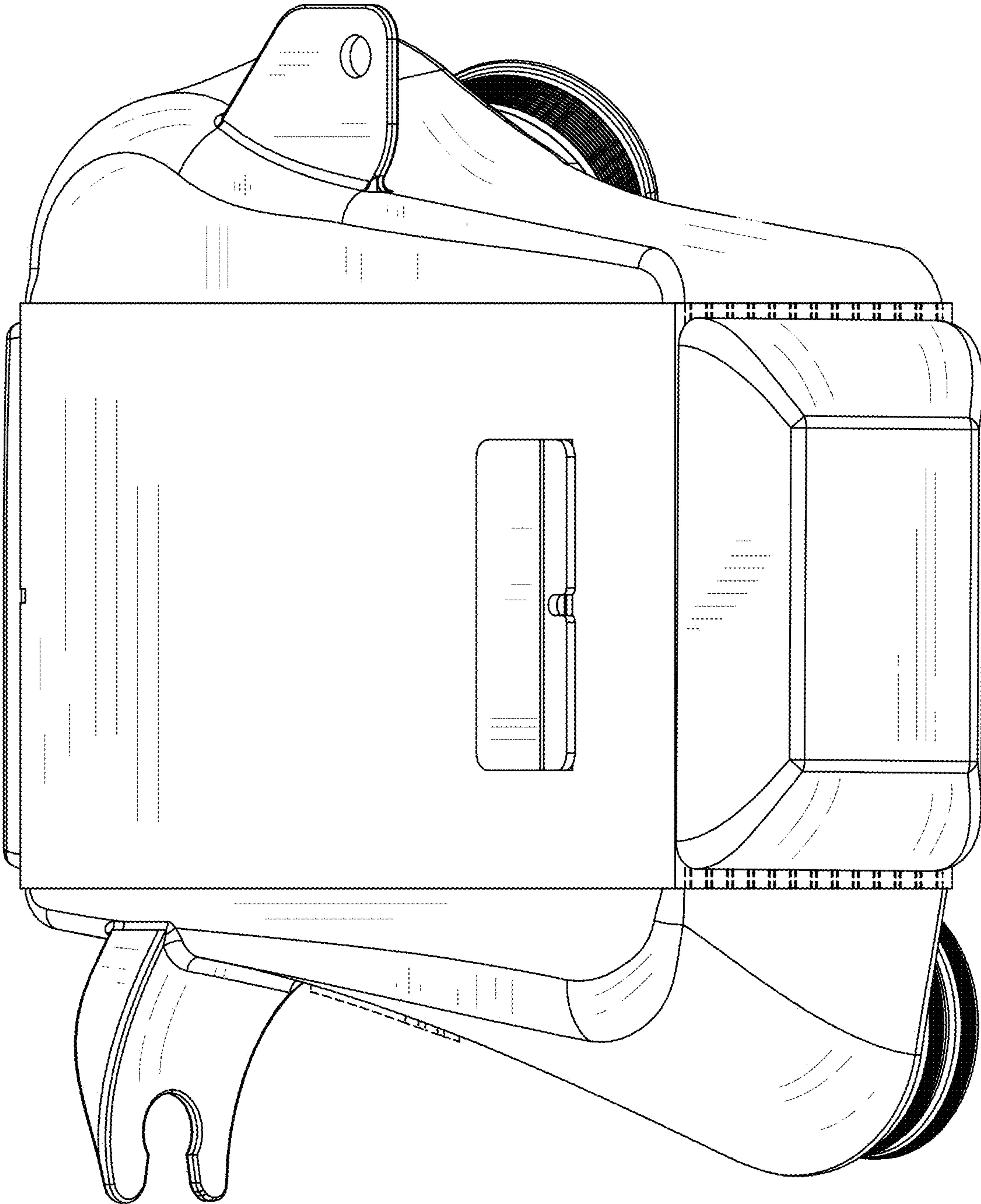

FIGURE 10