



US00D906946S

(12) **United States Design Patent** (10) **Patent No.:** **US D906,946 S**
Velet et al. (45) **Date of Patent:** **** Jan. 5, 2021**

(54) **UNIFIED PASSENGER SERVICE UNIT (PSU)**

D590,764 S * 4/2009 Yu D12/418
D592,285 S * 5/2009 Gao D23/255
D598,839 S * 8/2009 Wilhelm D12/418

(71) Applicant: **B/E Aerospace, Inc.**, Winston-Salem, NC (US)

(Continued)

(72) Inventors: **Alex L. Velet**, Clemmons, NC (US);
Haytham Hakla, Winston-Salem, NC (US);
Alexander Pozzi, Winston-Salem, NC (US)

OTHER PUBLICATIONS

Luminator Passenger Service Unit, Seaerospace.com [online], [site visited Jul. 17, 2020], URL: <https://www.seaerospace.com/sales/product/Luminator/0203841/0203841>, Year 2020.

(73) Assignee: **B/E Aerospace, Inc.**, Winston-Salem, NC (US)

(Continued)

(**) Term: **15 Years**

Primary Examiner — Katrina A Betton

(74) *Attorney, Agent, or Firm* — Suiter Swantz pc llo

(21) Appl. No.: **29/689,768**

(57) **CLAIM**

(22) Filed: **May 1, 2019**

The ornamental design for a unified passenger service unit, as shown and described.

Related U.S. Application Data

DESCRIPTION

(63) Continuation of application No. 16/363,710, filed on Mar. 25, 2019, and a continuation of application No. 15/977,753, filed on May 11, 2018.

FIG. 1 is a perspective view of a unified passenger service unit in a passenger seating environment;

(51) **LOC (13) Cl.** **12-16**

FIG. 2 is a perspective view of the unified passenger service unit of FIG. 1;

(52) **U.S. Cl.**
USPC **D12/418**

FIG. 3 is a right side elevation view of the unified passenger service unit of FIG. 1;

(58) **Field of Classification Search**
USPC D12/415–426.1, 400, 195, 190, 345, 96,
D12/99; D3/319; D9/423

FIG. 4 is a left side elevation view of the unified passenger service unit of FIG. 1;

CPC .. B60R 2011/0028; B60R 11/00; B64D 11/00
See application file for complete search history.

FIG. 5 is a top plan view of the unified passenger service unit of FIG. 1;

(56) **References Cited**

FIG. 6 is a bottom plan view of the unified passenger service unit of FIG. 1;

U.S. PATENT DOCUMENTS

FIG. 7 is a front elevation view of the unified passenger service unit of FIG. 1; and,

D244,018 S 4/1977 Greiss
D259,038 S 4/1981 Smith
D455,390 S 4/2002 Granzeier
D481,687 S 11/2003 Moriya
D562,779 S 2/2008 Lamoree
D583,749 S * 12/2008 Aruga D12/418

FIG. 8 is a rear elevation view of the unified passenger service unit of FIG. 1.

Portions of FIGS. 1, 2, and 7 are shown in broken lines, illustrating portions of the article of manufacture that form no part of the claimed design.

1 Claim, 8 Drawing Sheets

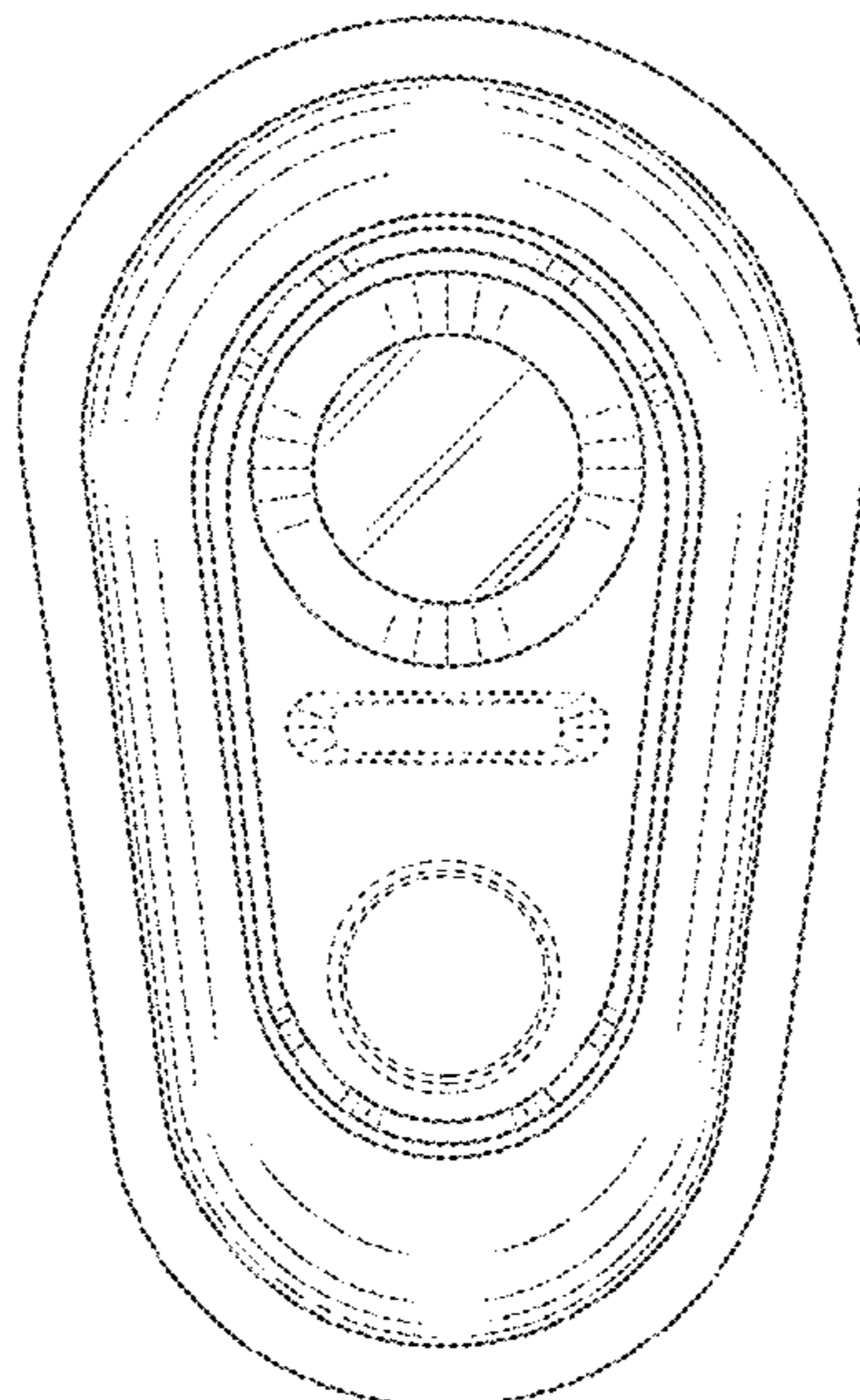

(56)

References Cited

U.S. PATENT DOCUMENTS

D600,623 S 9/2009 Fiedler
 D613,669 S 4/2010 Collins
 D628,529 S * 12/2010 Fiedler D12/345
 7,880,131 B2 2/2011 Andre et al.
 7,884,315 B2 2/2011 Andre et al.
 D690,255 S 9/2013 Schutterra
 8,729,457 B2 5/2014 Andre et al.
 8,735,800 B2 5/2014 Andre et al.
 D706,706 S 6/2014 Schutterra
 D724,003 S * 3/2015 Fonseca D12/418
 D750,007 S 2/2016 Smallhorn
 D752,502 S 3/2016 Paulino
 D756,891 S * 5/2016 Roth D12/418
 9,377,821 B2 6/2016 Andre et al.
 D761,187 S 7/2016 Castanha
 9,423,835 B2 8/2016 Andre et al.
 D784,904 S 4/2017 Schutterra et al.
 D786,171 S 5/2017 Smallhorn
 D786,770 S 5/2017 Smallhorn
 D787,420 S 5/2017 Smallhorn
 D788,017 S 5/2017 Smallhorn
 D795,161 S 8/2017 Schutterra
 D795,786 S 8/2017 Smallhorn
 D797,642 S 9/2017 Smallhorn
 D797,643 S 9/2017 Smallhorn
 D797,644 S 9/2017 Smallhorn
 D813,146 S * 3/2018 Donckerwolke D12/418
 D821,947 S 7/2018 Kasparian
 10,034,349 B2 7/2018 Andre et al.
 10,034,350 B2 7/2018 Andre et al.

D845,211 S * 4/2019 Baek D12/418
 D858,392 S 9/2019 Pugliesi
 D870,640 S * 12/2019 de Andrade Lima D12/345
 10,507,925 B2 12/2019 Pugliesi
 D875,641 S 2/2020 Schutterra
 D879,009 S 3/2020 Smallhorn
 10,611,480 B2 4/2020 Hessling-Von Heimendahl
 2008/0112155 A1 5/2008 Scown
 2012/0230530 A1 9/2012 Schevarado
 2013/0039020 A1 2/2013 Rittner
 2015/0016129 A1 1/2015 Castanha
 2015/0090839 A1 4/2015 Freund
 2017/0203856 A1 7/2017 Dunn et al.
 2018/0136733 A1 5/2018 Schalla et al.
 2018/0324927 A1 11/2018 Andre et al.
 2018/0324928 A1 11/2018 Andre et al.
 2019/0329889 A1 10/2019 Afonso et al.
 2019/0344891 A1 * 11/2019 Hakla B64D 13/06
 2019/0344892 A1 11/2019 Pozzi

OTHER PUBLICATIONS

Standard Overhead Passenger Service Unit on Board an Air France A319. Air Vents!, Airline Reporter.com, by John Nguyen, Oct. 6, 2015, [online], [site visited Jul. 17, 2020]. URL: <https://www.airlinereporter.com/2015/11/not-best-air-france-economy-flight/dsc0358/>, Year 2015.
 Full Report: Inaugural Flight of Widero3's First Embraer E190-E2 (+Photos), AirwaysMag.com, Apr. 26, 2018, 13:00 by Roberto Leiro, [online], [site visited Jul. 17, 2020]. URL: <https://airwaysmag.com/airlines/wideroes-embraer-e190-e2-flight/>, Year 2018.

* cited by examiner

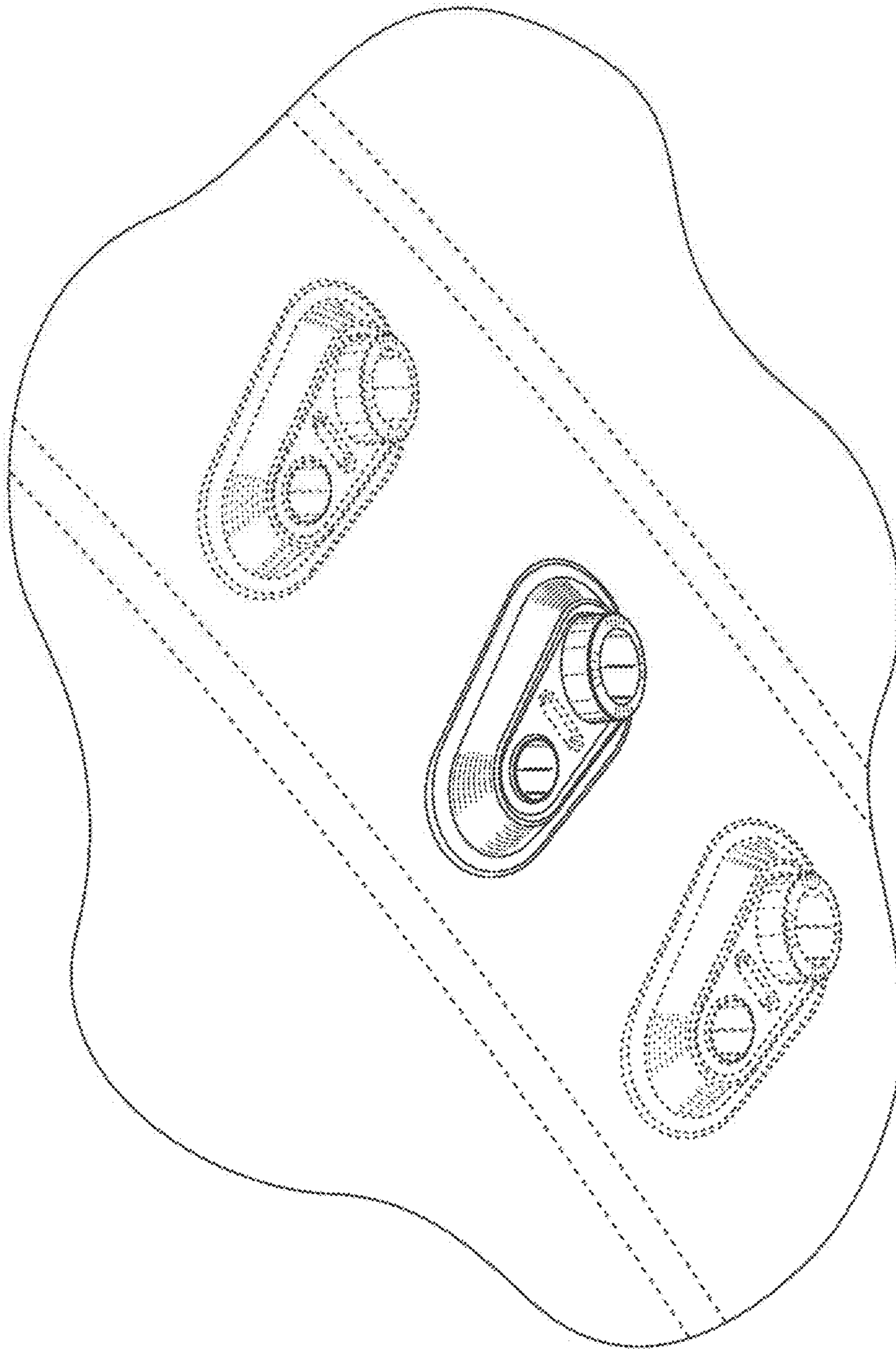

FIG. 1

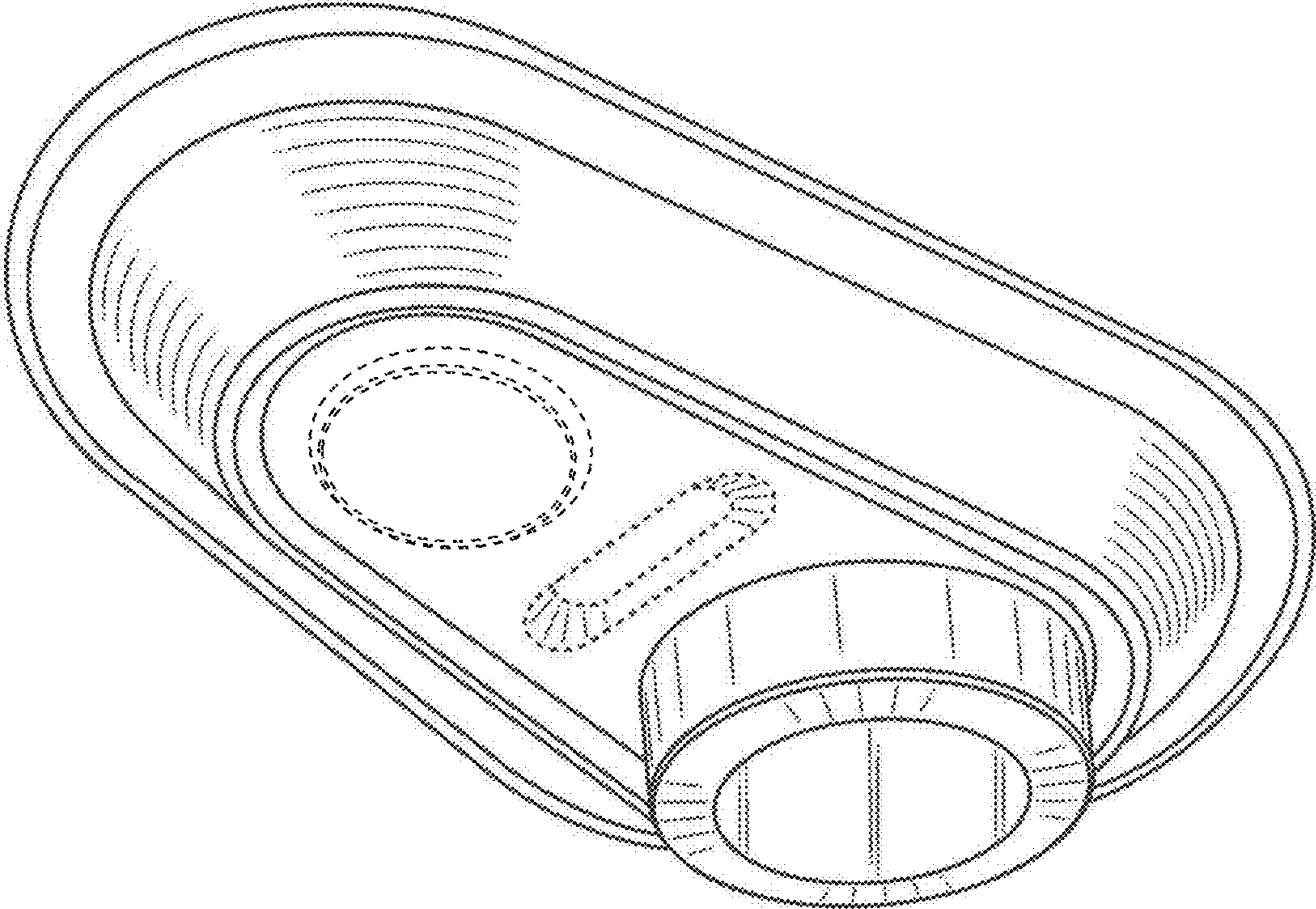

FIG. 2

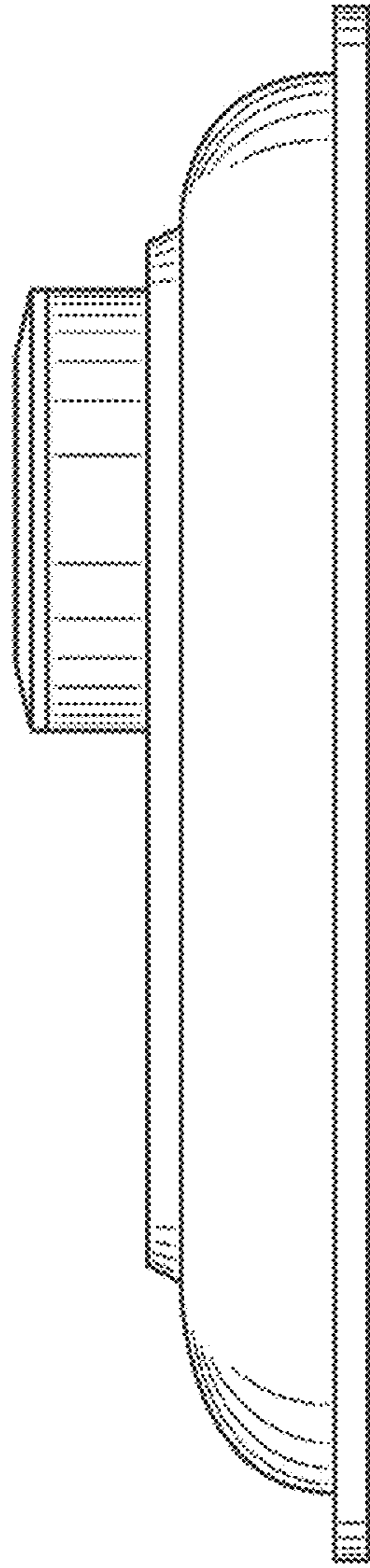

FIG. 3

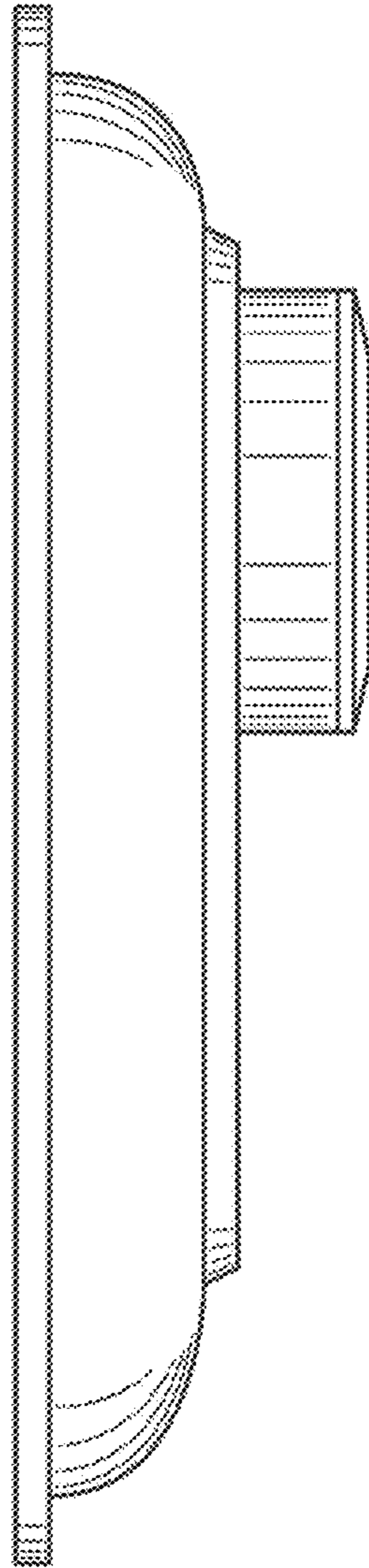

FIG. 4

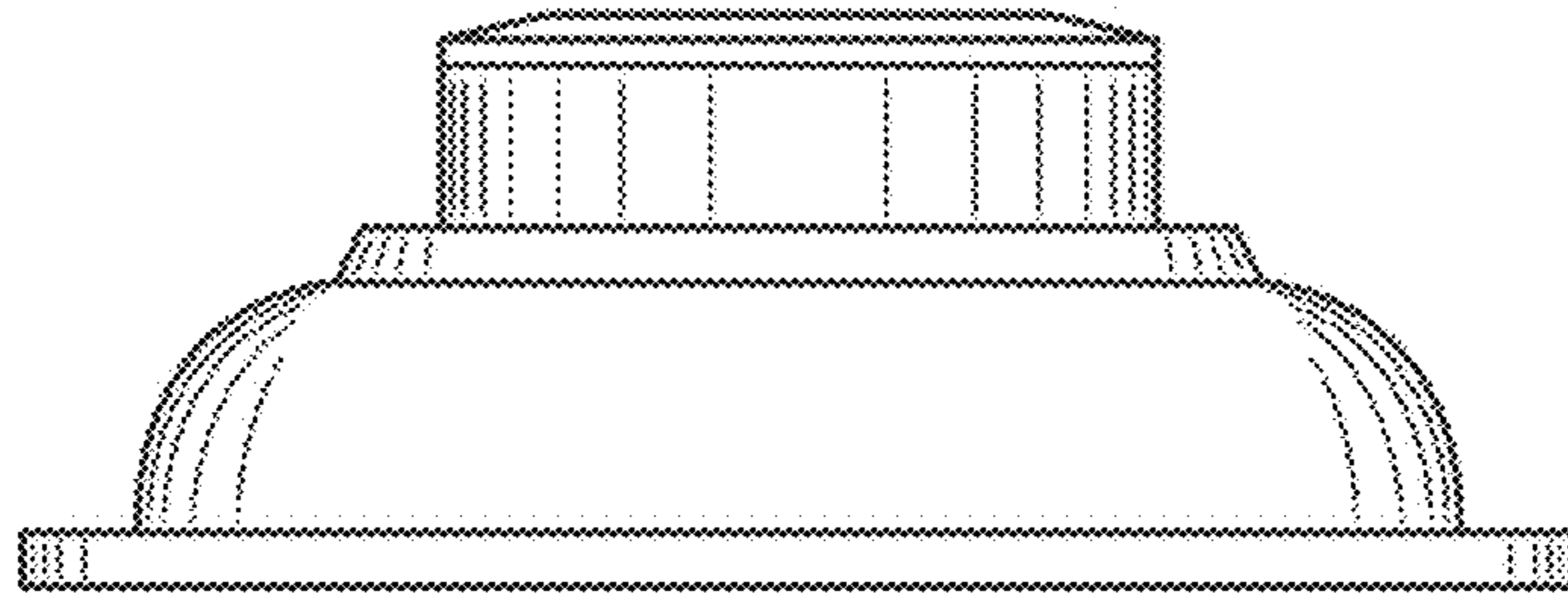

FIG. 5

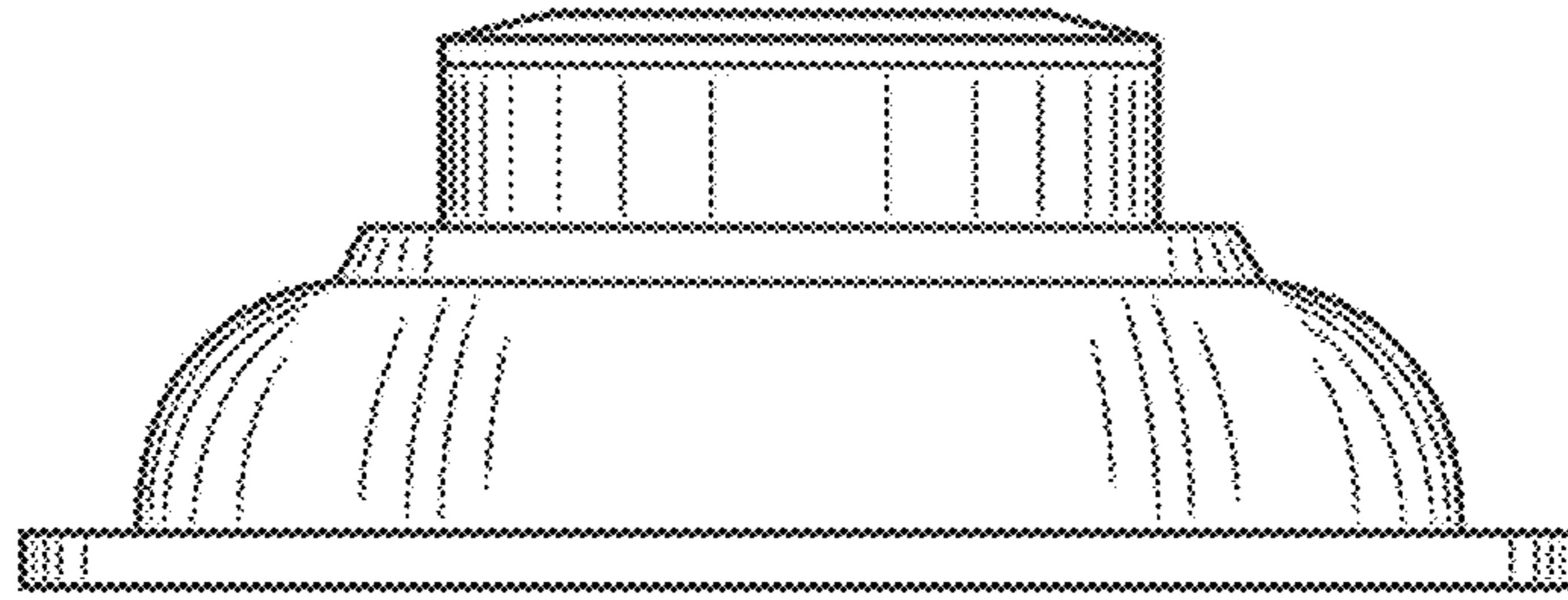

FIG. 6

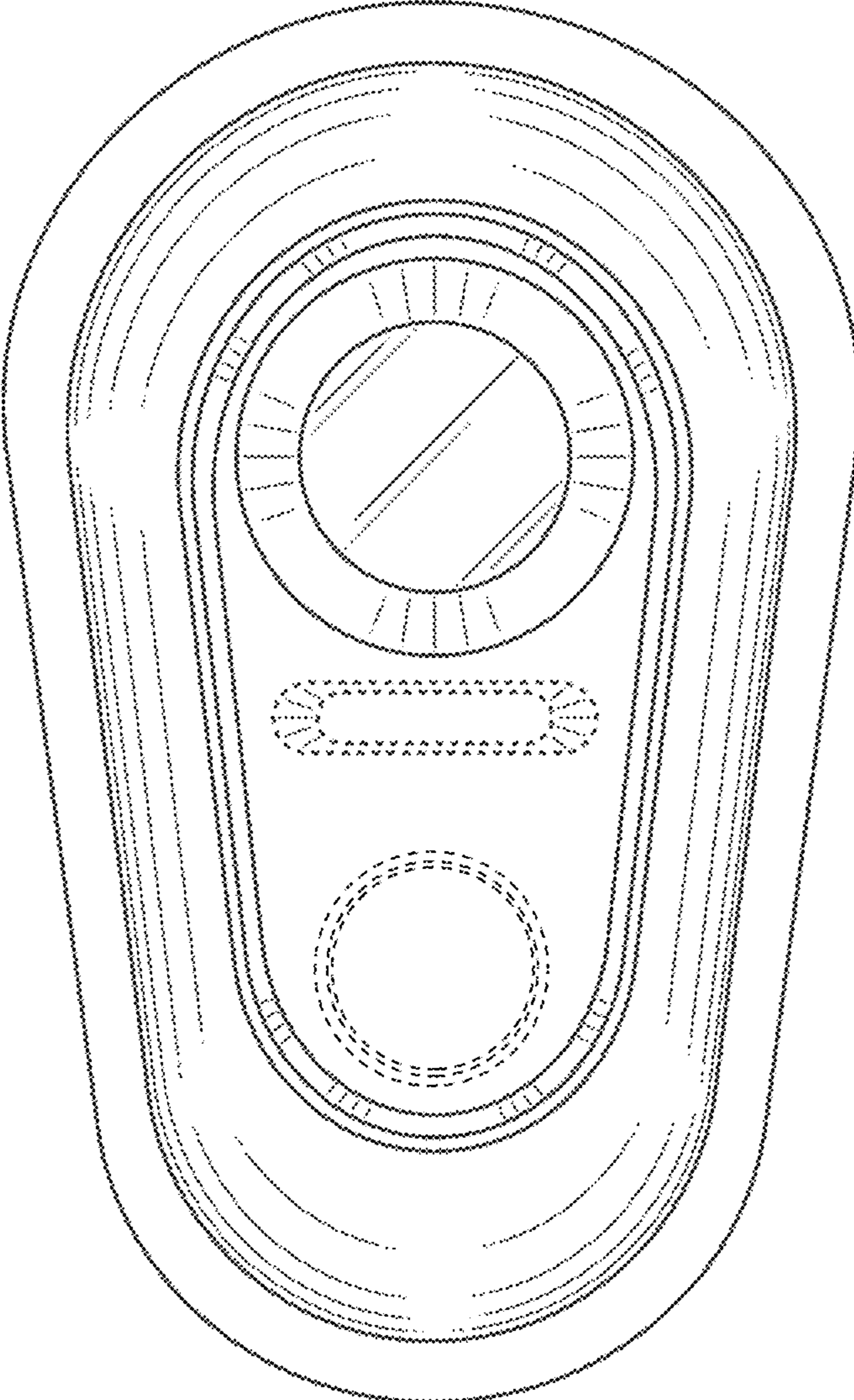

FIG. 7

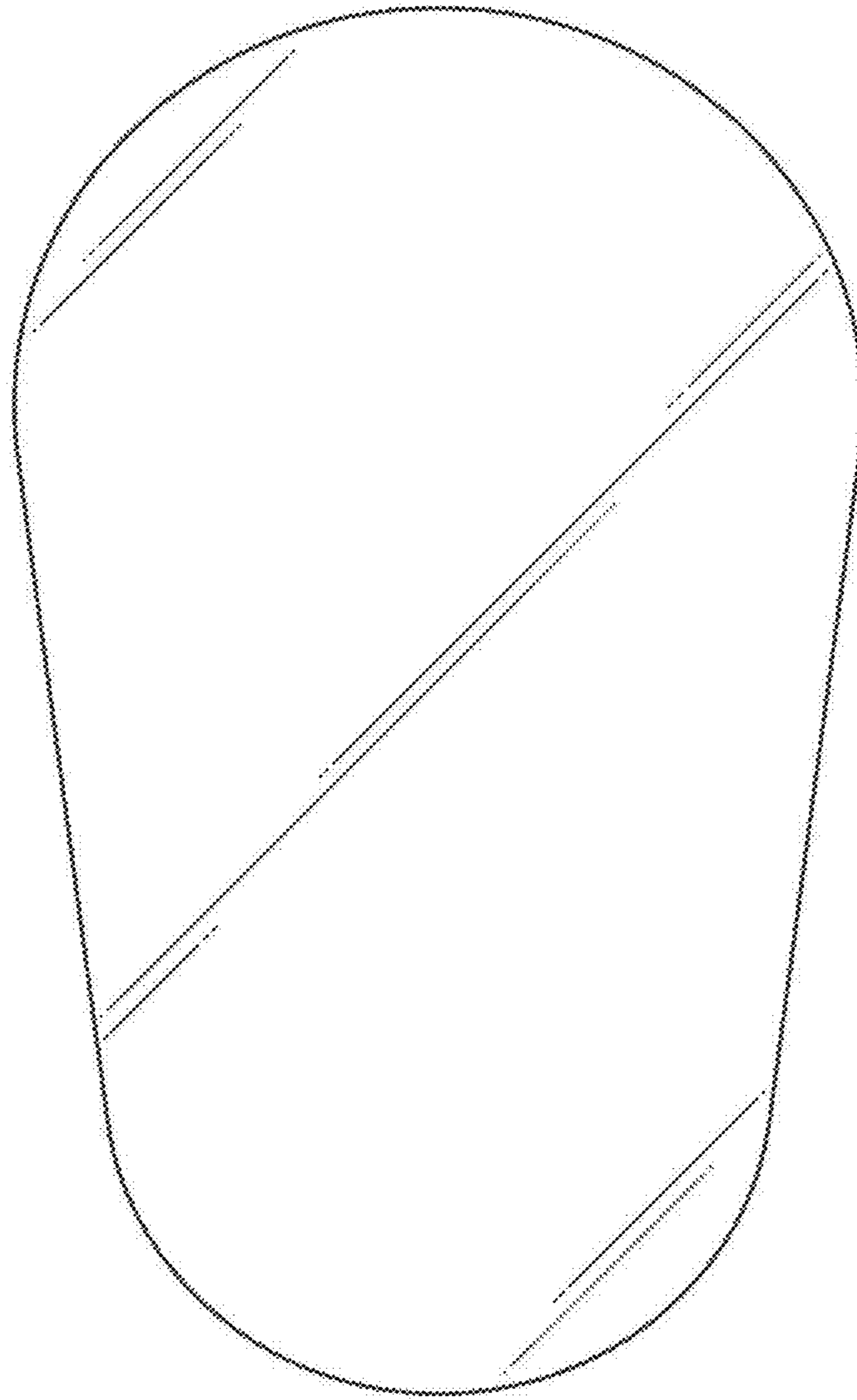

FIG. 8