



US00D906944S

(12) **United States Design Patent**
Velet et al.

(10) **Patent No.:** **US D906,944 S**
(45) **Date of Patent:** **** Jan. 5, 2021**

(54) **UNIFIED PASSENGER SERVICE UNIT**

- (71) Applicant: **B/E Aerospace, Inc.**, Winston-Salem, NC (US)
- (72) Inventors: **Alex L. Velet**, Clemmons, NC (US);
Haytham Hakla, Winston-Salem, NC (US);
Alexander Pozzi, Winston-Salem, NC (US)
- (73) Assignee: **B/E Aerospace, Inc.**, Winston-Salem, NC (US)
- (**) Term: **15 Years**
- (21) Appl. No.: **29/689,764**
- (22) Filed: **May 1, 2019**

Related U.S. Application Data

- (63) Continuation of application No. 16/363,710, filed on Mar. 25, 2019, and a continuation of application No. 15/977,753, filed on May 11, 2018.
- (51) **LOC (13) Cl.** **12-07**
- (52) **U.S. Cl.**
USPC **D12/345; D12/415**
- (58) **Field of Classification Search**
USPC D12/1-4, 16.1, 319-345, 414, 415, 417,
D12/418, 423, 190, 195; D21/436-454;
D15/17, 28; D10/46, 98, 102, 103
CPC B64C 39/024; B64C 13/16; B64C 19/00;
B64C 2201/021; B64C 2201/141; B60H
1/3442; B60J 5/04
See application file for complete search history.

(56) **References Cited**

U.S. PATENT DOCUMENTS

- D244,018 S * 4/1977 Greiss D12/195
- D259,038 S * 4/1981 Smith D12/195
- D455,390 S * 4/2002 Granzeier D12/345

(Continued)

OTHER PUBLICATIONS

Luminator Passenger Service Unit, Seaerospace.com, [online], [site visited Jul. 17, 2020]. <URL: <https://www.seaerospace.com/sales/product/Luminator/0203841/0203841>> (Year: 2020).*

(Continued)

Primary Examiner — T Chase Nelson
Assistant Examiner — Jonathan J. Han

(74) *Attorney, Agent, or Firm* — Suiter Swantz pc llo

(57) **CLAIM**

The ornamental design for a unified passenger service unit, as shown and described.

DESCRIPTION

FIG. 1 is a perspective view of a unified passenger service unit in a passenger seating environment;
 FIG. 2 is an enlarged perspective view of the unified passenger service unit of FIG. 1 with the environment shown in that view removed;
 FIG. 3 is a right side elevation view of the unified passenger service unit of FIG. 2;
 FIG. 4 is a left side elevation view of the unified passenger service unit of FIG. 2;
 FIG. 5 is a top plan view of the unified passenger service unit of FIG. 2;
 FIG. 6 is a bottom plan view of the unified passenger service unit of FIG. 2;
 FIG. 7 is a front elevation view of the unified passenger service unit of FIG. 2; and,
 FIG. 8 is a rear elevation view of the unified passenger service unit of FIG. 2.

The broken lines in FIGS. 1, 2, and 7 illustrate portions of the invention and environment that form no part of the claimed design. The dash-dot-dash broken lines are used to enclose the environment in FIG. 1 and form no part of the claimed design.

1 Claim, 8 Drawing Sheets

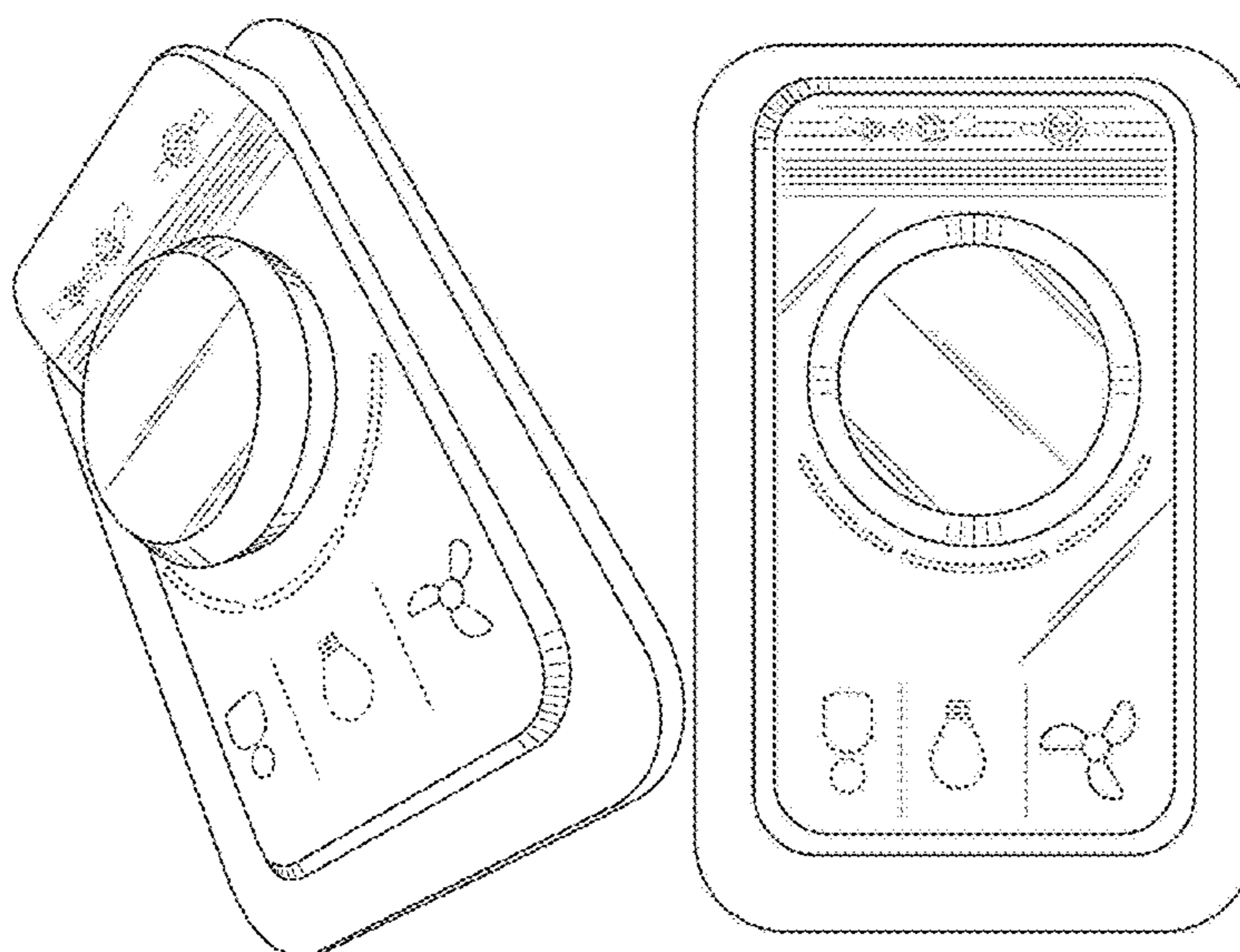

(56)

References Cited

U.S. PATENT DOCUMENTS

D481,687 S * 11/2003 Moriya D13/171
 D562,779 S * 2/2008 Lamoree D13/171
 D600,623 S * 9/2009 Fiedler D12/345
 D613,669 S * 4/2010 Collins D12/345
 D628,529 S * 12/2010 Fiedler D12/345
 7,880,131 B2 2/2011 Andre et al.
 7,884,315 B2 2/2011 Andre et al.
 D690,255 S * 9/2013 Schutterra D12/345
 8,729,457 B2 5/2014 Andre et al.
 8,735,800 B2 5/2014 Andre et al.
 D706,706 S * 6/2014 Schutterra D12/345
 D750,007 S * 2/2016 Smallhorn D12/345
 D752,502 S * 3/2016 Paulino D12/345
 9,377,821 B2 6/2016 Andre et al.
 D761,187 S * 7/2016 Castanha D12/345
 9,423,835 B2 8/2016 Andre et al.
 D784,904 S 4/2017 Schutterra et al.
 D786,171 S * 5/2017 Smallhorn D12/345
 D786,770 S * 5/2017 Smallhorn D12/345
 D787,420 S * 5/2017 Smallhorn D12/345
 D788,017 S * 5/2017 Smallhorn D12/345
 D795,161 S * 8/2017 Schutterra D12/345
 D795,786 S * 8/2017 Smallhorn D12/345
 D797,642 S * 9/2017 Smallhorn D12/345
 D797,643 S * 9/2017 Smallhorn D12/345
 D797,644 S * 9/2017 Smallhorn D12/345
 D821,947 S * 7/2018 Kasparian D12/195
 10,034,349 B2 7/2018 Andre et al.
 10,034,350 B2 7/2018 Andre et al.
 D858,392 S * 9/2019 Pugliesi D12/195
 D870,640 S * 12/2019 de Andrade Lima D12/345
 10,507,925 B2 * 12/2019 Pugliesi B60H 1/3414
 D875,641 S * 2/2020 Schutterra D12/345

D879,009 S * 3/2020 Smallhorn D12/345
 10,611,480 B2 * 4/2020 Hessling-Von Heimendahl
 B64D 11/00
 2008/0112155 A1 * 5/2008 Scown B60H 1/3442
 362/96
 2012/0230530 A1 * 9/2012 Schevarado B60Q 3/44
 381/333
 2013/0039020 A1 * 2/2013 Rittner B64D 11/0015
 361/740
 2015/0016129 A1 * 1/2015 Castanha A62B 7/14
 362/471
 2015/0090839 A1 * 4/2015 Freund B64D 47/02
 244/118.5
 2017/0203856 A1 7/2017 Dunn et al.
 2018/0136733 A1 5/2018 Schalla et al.
 2018/0324927 A1 11/2018 Andre et al.
 2018/0324928 A1 11/2018 Andre et al.
 2019/0329889 A1 10/2019 Afonso et al.
 2019/0344891 A1 * 11/2019 Hakla B64D 13/06
 2019/0344892 A1 * 11/2019 Pozzi G05G 1/105

OTHER PUBLICATIONS

Standard Overhead Passenger Service Unit on Board an Air France A319. Air Vents!, AirlineReporter.com, By John Nguyen, Oct. 6, 2015, [online], [site visited Jul. 17, 2020]. <URL: https://www.airlinereporter.com/2015/11/not-best-air-france-economy-flight/dsc_0358/> (Year: 2015).*

Full Report: Inaugural Flight of Widero3's First Embraer E190-E2 (+Photos), AirwaysMag.com, Apr. 26, 2018, 13:00 by Roberto Leiro, [online], [site visited Jul. 17, 2020]. <URL: <https://airwaysmag.com/airlines/wideroes-ennbraer-e190-e2-flight/>> (Year: 2018).*

* cited by examiner

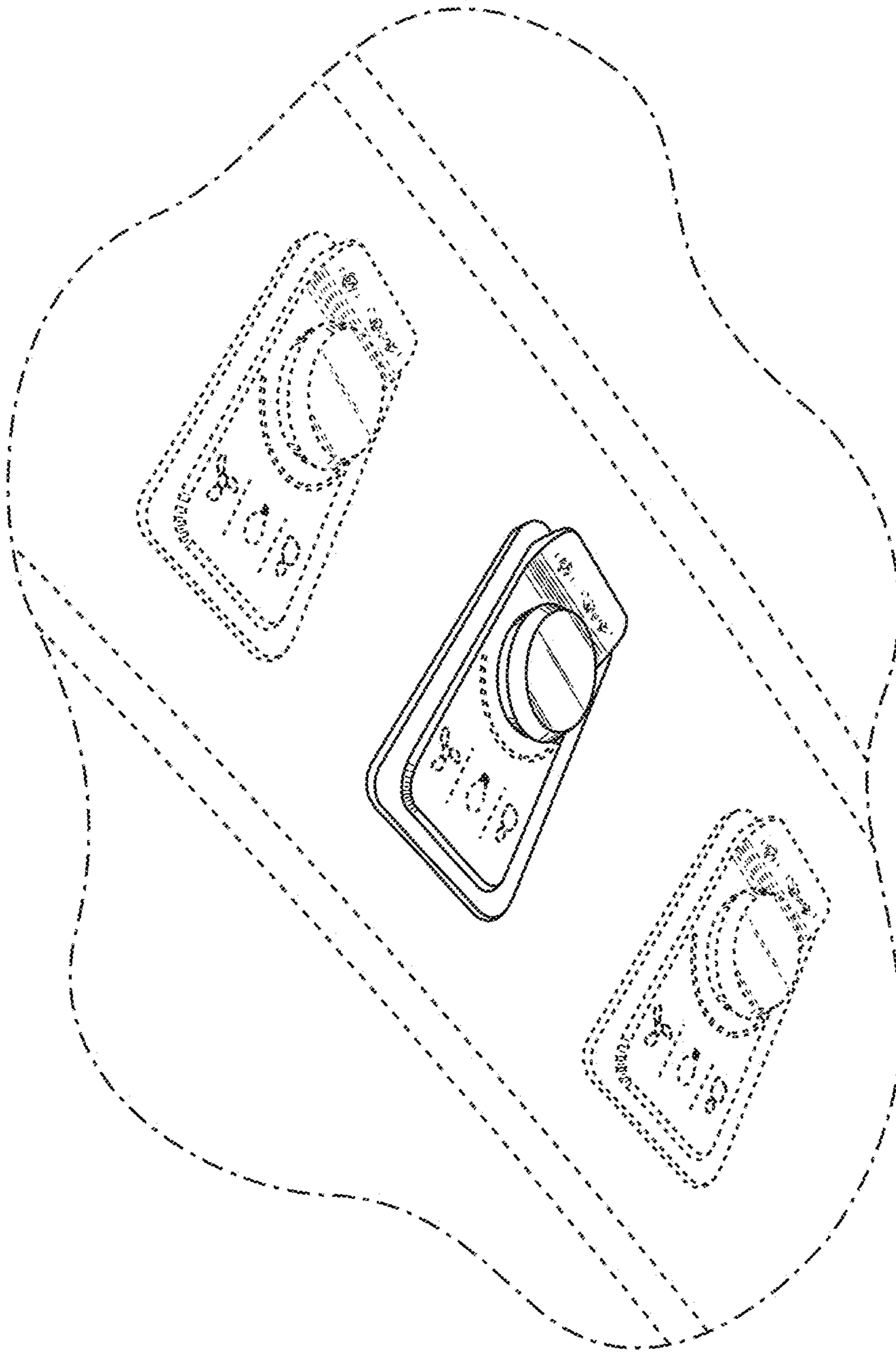

FIG. 1

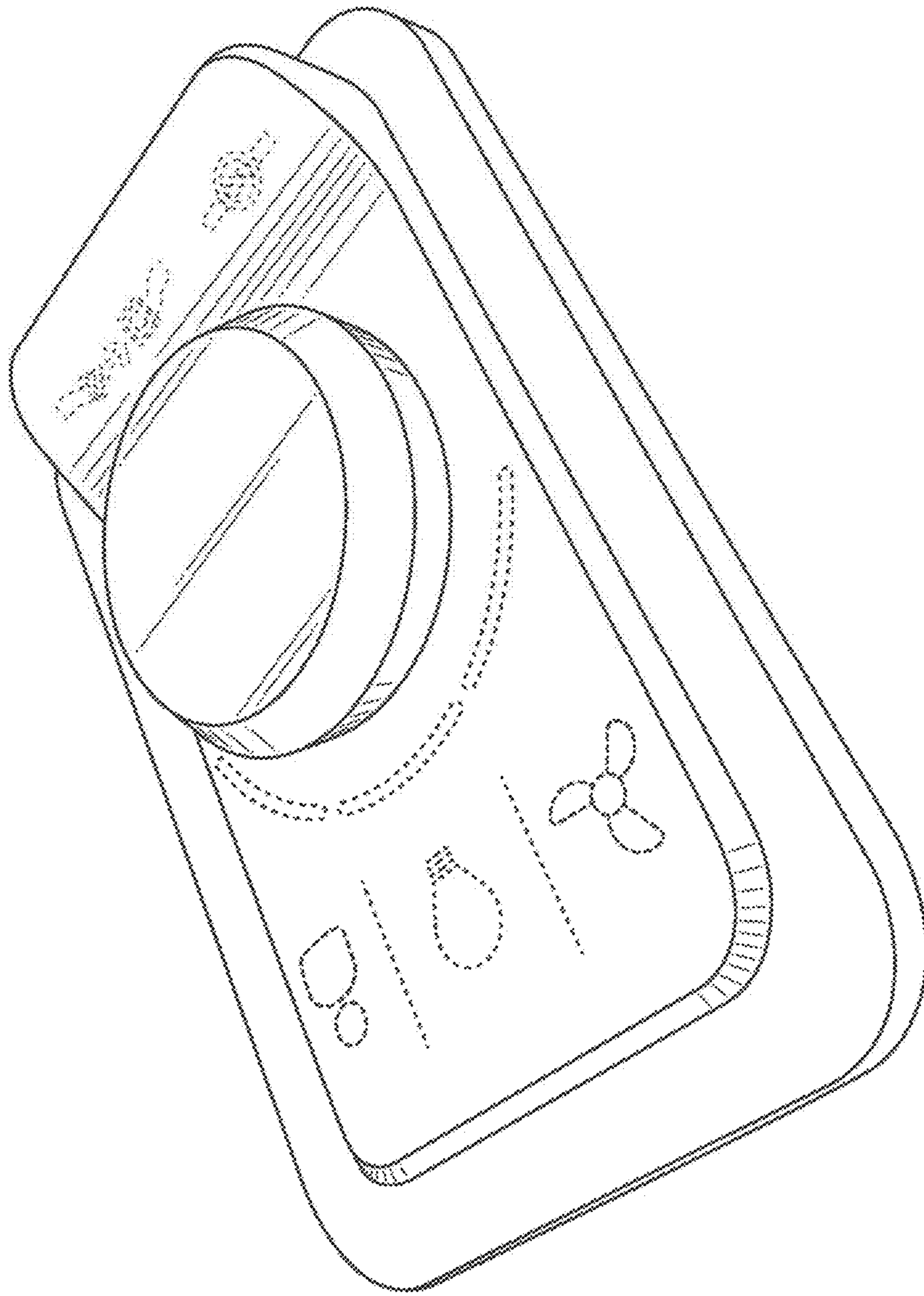

FIG. 2

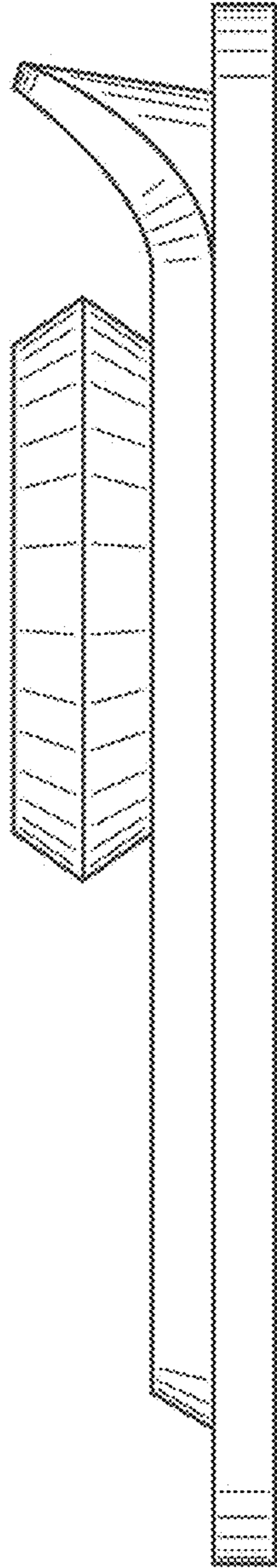

FIG. 3

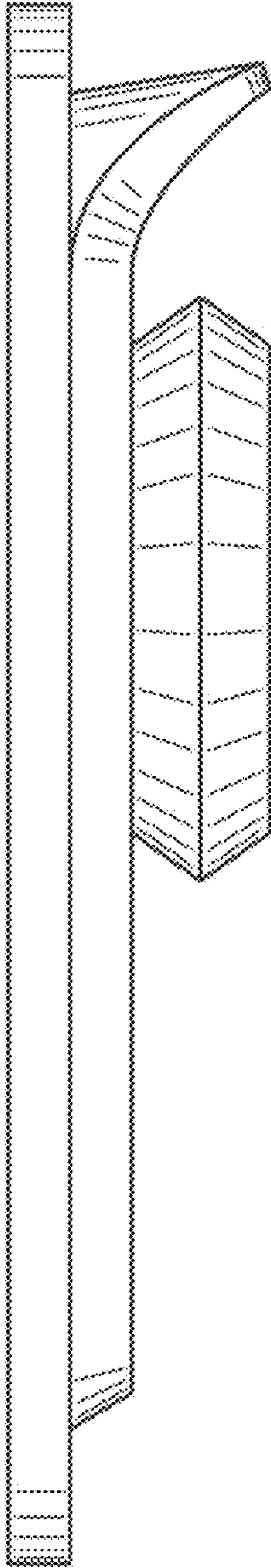

FIG. 4

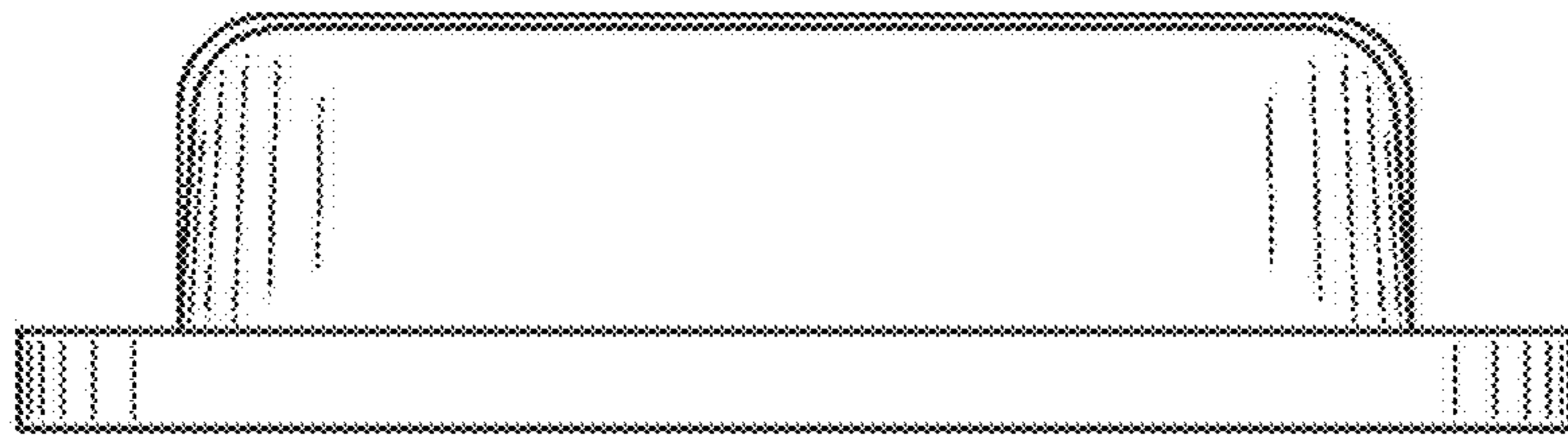

FIG. 5

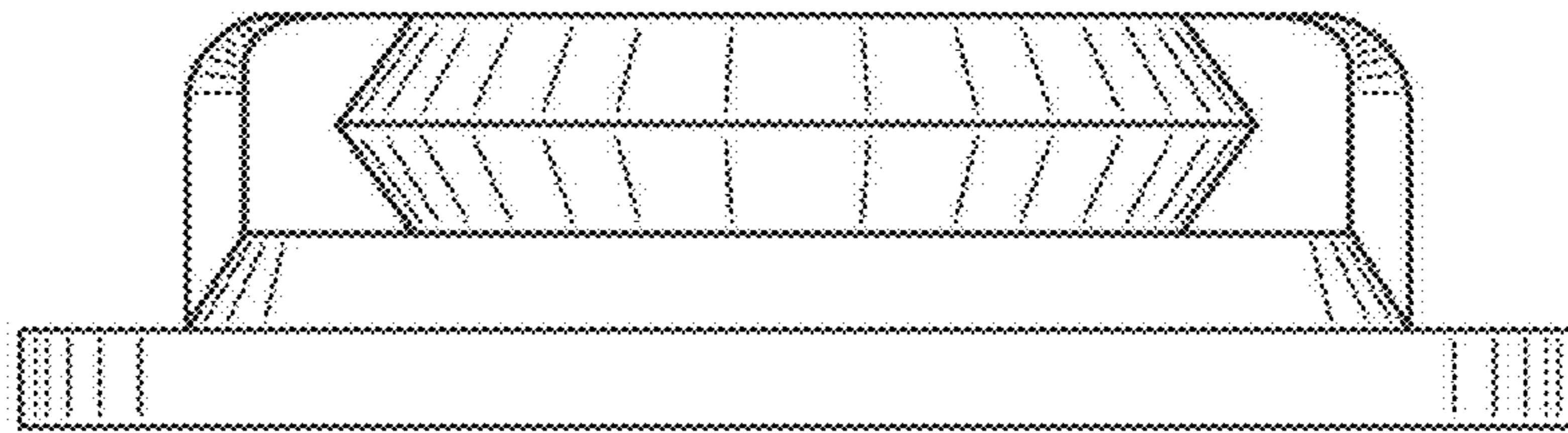

FIG. 6

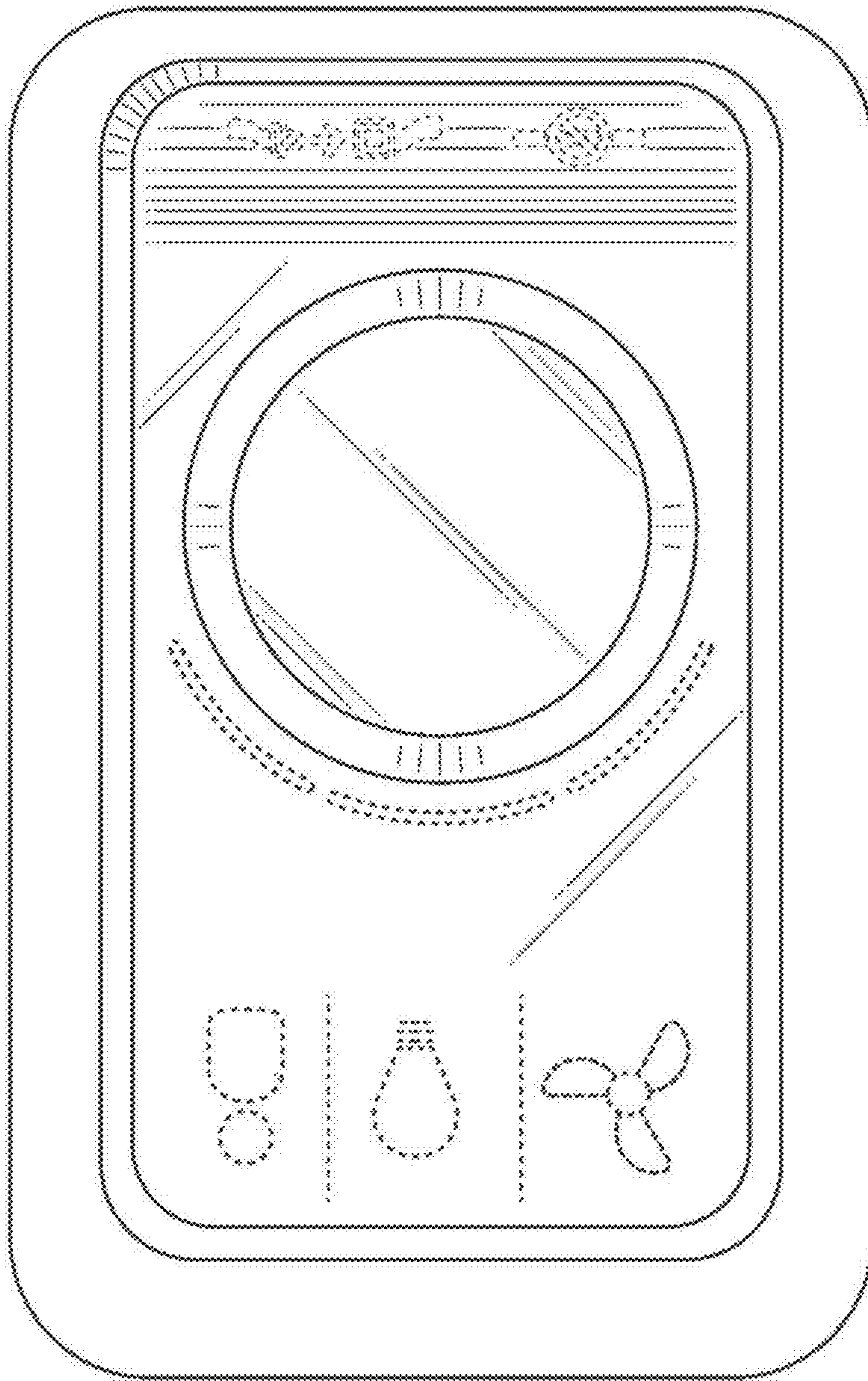

FIG. 7

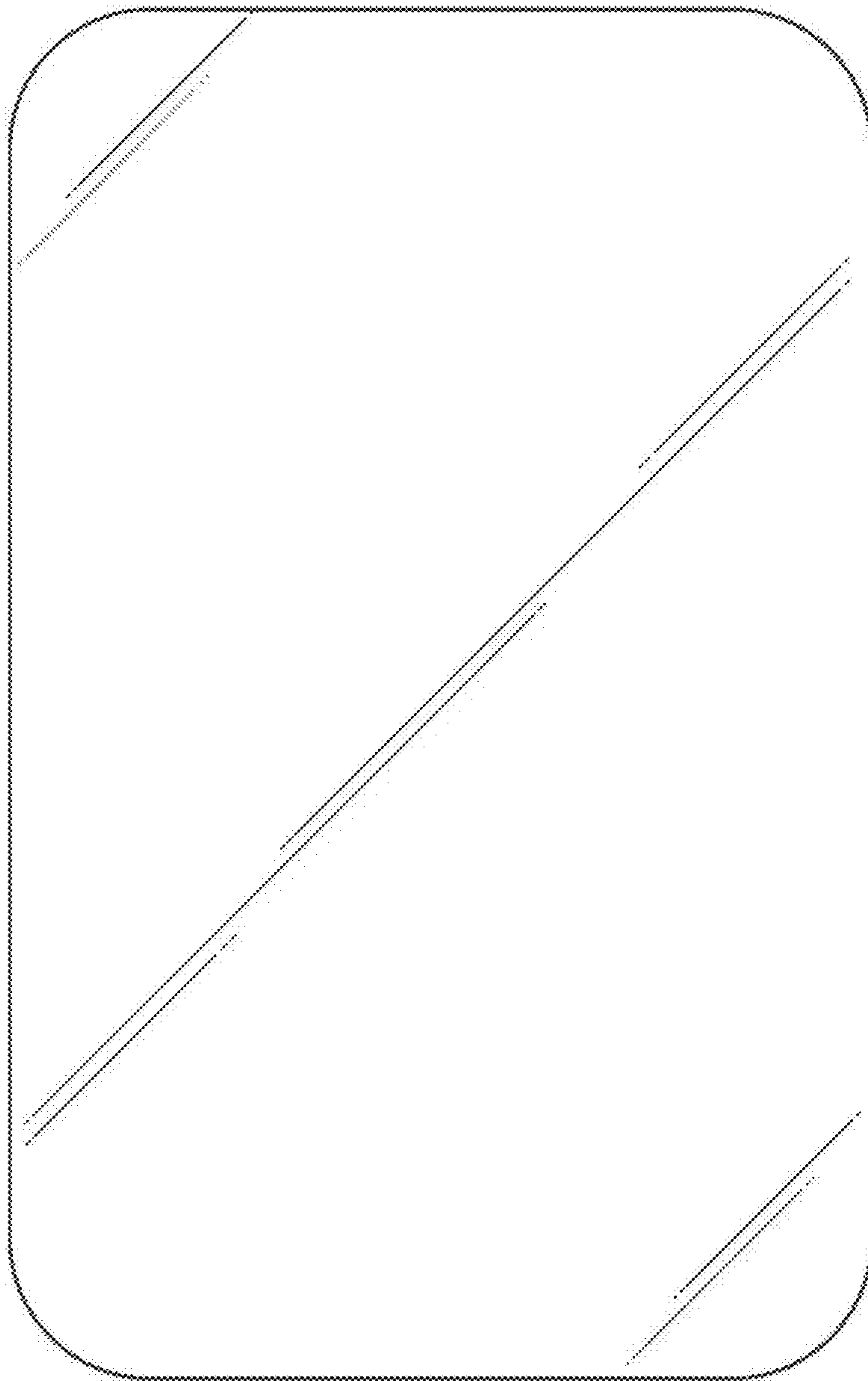

FIG. 8