



US00D906902S

(12) **United States Design Patent**  
**Duncan et al.**

(10) **Patent No.:** **US D906,902 S**  
(45) **Date of Patent:** **\*\* Jan. 5, 2021**

- (54) **GRILLE SURROUND PROFILE**
- (71) Applicant: **PACCAR Inc**, Bellevue, WA (US)
- (72) Inventors: **Jonathan S. Duncan**, Seattle, WA (US); **Amanda Koh**, Kenmore, WA (US); **Peter Vurpillat**, Seattle, WA (US); **Chris Small**, Seattle, WA (US); **John Jackson**, Sammamish, WA (US); **Rebecca Kern**, Kent, WA (US)

2,083,785 A 6/1937 Harrison, Jr.  
 D250,018 S 10/1978 Barbera  
 D280,609 S 9/1985 Walter et al.  
 (Continued)

FOREIGN PATENT DOCUMENTS

CN 201607029 U 10/2010  
 CN 202511694 U 10/2012  
 (Continued)

OTHER PUBLICATIONS

“T270 Class 6 and T370 Class 7 Hybrid,” Kenworth Truck Company, Kirkland, Washington, 2009, 6-page brochure.  
 (Continued)

*Primary Examiner* — Dana K Weiland  
*Assistant Examiner* — Messina L Smith  
 (74) *Attorney, Agent, or Firm* — Seed IP Law Group  
 LLP; Jared M. Barrett

- (73) Assignee: **PACCAR Inc**, Bellevue, WA (US)
- (\*\*) Term: **15 Years**
- (21) Appl. No.: **29/644,078**
- (22) Filed: **Apr. 13, 2018**
- (51) **LOC (13) Cl.** ..... **12-16**
- (52) **U.S. Cl.**  
 USPC ..... **D12/163**
- (58) **Field of Classification Search**  
 USPC ... D14/141.1, 159, 218, 219, 220, 221, 222,  
 D14/223, 224, 224.1, 225, 227, 228, 229,  
 D14/259, 341, 344, 345, 299; D12/216,  
 D12/190, 163  
 CPC . H04R 1/00; H04R 1/02; H04R 1/326; H04R  
 1/406; H04R 1/083; H04R 1/222; H04R  
 1/1041; H04R 1/023; H04R 7/00; H04R  
 7/20; H04R 27/00; H04R 2201/00; H04R  
 2400/00; H04R 17/02; H04R 29/004;  
 H04R 29/005; H04R 19/04; H04R  
 2420/07; H04R 2410/00; H04R 2410/01;  
 H04R 5/02; G02B 27/01  
 See application file for complete search history.

(57) **CLAIM**

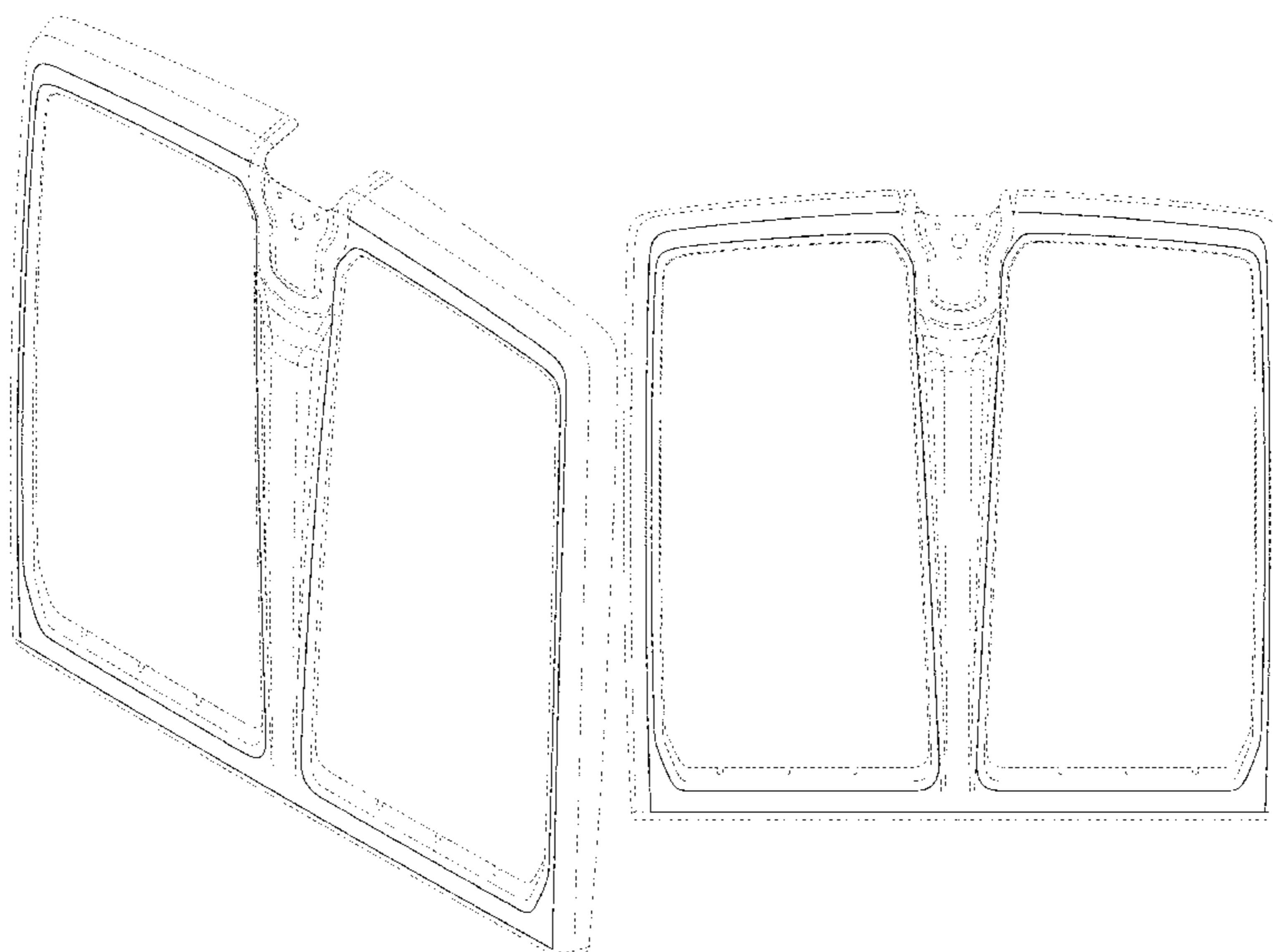
The ornamental design for a grille surround profile, as shown and described.

**DESCRIPTION**

FIG. 1 is a perspective view of a grille surround profile showing our new design;  
 FIG. 2 is a front view of the grille surround profile shown in FIG. 1;  
 FIG. 3 is a top view of the grille surround profile shown in FIG. 1;  
 FIG. 4 is a left side view of the grille surround profile shown in FIG. 1; and,  
 FIG. 5 is a right side view of the grille surround profile shown in FIG. 1.  
 The broken lines shown in the figures represent portions of the grille surround profile that form no part of the claimed design. The dash-dot broken lines define the boundaries of the claim and form no part of the claimed design.

- (56) **References Cited**  
 U.S. PATENT DOCUMENTS  
 D50,345 S 2/1917 Green  
 D50,346 S 2/1917 Green

**1 Claim, 3 Drawing Sheets**



(56)

References Cited

U.S. PATENT DOCUMENTS

D284,180 S	6/1986	Abe	D513,212 S	12/2005	Pfeiffer et al.
D284,366 S	6/1986	Abe	D514,483 S	2/2006	Chiang
D311,711 S	10/1990	Marlowe et al.	D515,474 S	2/2006	Wu
D313,784 S	1/1991	Marlow et al.	D517,965 S	3/2006	Metros et al.
D327,276 S	6/1992	Sorensen	D518,761 S	4/2006	Chiang
D361,968 S	9/1995	Oyama	D519,426 S	4/2006	Ikeda
D366,638 S	1/1996	Tucker et al.	D522,935 S	6/2006	Marchese et al.
D366,640 S	1/1996	Tucker et al.	D522,936 S	6/2006	Beigel et al.
5,525,145 A	6/1996	Hodge	D523,791 S	6/2006	Pfeiffer
D378,812 S	4/1997	Aycock	D523,793 S	6/2006	Beigel et al.
D382,239 S	8/1997	Logan et al.	D524,204 S	7/2006	Beigel
D382,841 S	8/1997	Norwood et al.	D526,605 S	8/2006	Chung
D382,844 S	8/1997	Norwood et al.	D526,941 S	8/2006	Yamashita
D389,108 S	1/1998	Norwood et al.	D527,694 S	9/2006	Chung
D395,860 S	7/1998	Meryman et al.	D528,050 S	9/2006	McCuller et al.
D396,028 S	7/1998	Needham	D530,247 S	10/2006	Angelo
D396,677 S	8/1998	Sacco et al.	D531,554 S	11/2006	Conkey et al.
D400,835 S	11/1998	Le Quement et al.	D531,555 S	11/2006	Hooper
D401,198 S	11/1998	Mueller et al.	D531,947 S	11/2006	Angelo et al.
D403,285 S	12/1998	Abalos et al.	D532,350 S	11/2006	Angelo et al.
D403,636 S	1/1999	Meryman et al.	D532,352 S	11/2006	Angelo et al.
D403,639 S	1/1999	Gale et al.	D535,431 S	1/2007	Roland
D405,037 S	2/1999	Meryman et al.	D535,591 S	1/2007	Schiavone
D406,636 S	3/1999	Male et al.	D538,207 S	3/2007	Pfeiffer
D411,494 S	6/1999	Meryman et al.	D539,194 S	3/2007	Moses
D412,689 S	8/1999	Onopa	D539,704 S	4/2007	Angelo et al.
D412,874 S	8/1999	Meryman et al.	D540,725 S	4/2007	Gunter et al.
D421,734 S	3/2000	Sacco et al.	D540,727 S	4/2007	Elliott et al.
6,041,878 A	3/2000	Daniels et al.	D545,250 S	6/2007	Angelo et al.
D422,251 S	4/2000	Bader et al.	D545,251 S	6/2007	Angelo et al.
D424,993 S	5/2000	Farzam	D545,254 S	6/2007	Angelo et al.
D425,835 S	5/2000	Cook et al.	D545,255 S	6/2007	Angelo et al.
6,085,481 A	7/2000	Lee	D545,728 S	7/2007	Golden et al.
D431,806 S	10/2000	Damon et al.	D545,730 S	7/2007	Lee et al.
D433,655 S	11/2000	Sacco et al.	D545,735 S	7/2007	Angelo et al.
D433,980 S	11/2000	Conway et al.	D549,072 S	8/2007	Davidson
D434,358 S	11/2000	Conway et al.	D551,133 S	9/2007	Angelo
D435,816 S	1/2001	Delashaw et al.	D551,599 S	9/2007	Simons et al.
D436,066 S	1/2001	Wagner	D551,600 S	9/2007	Simons et al.
D436,563 S	1/2001	Delashaw et al.	D560,575 S	1/2008	Simons et al.
D439,209 S	3/2001	Pfeiffer	D560,582 S	1/2008	Simons et al.
D443,853 S	6/2001	Barracough et al.	D560,583 S	1/2008	Simons et al.
D445,383 S	7/2001	Price	D562,196 S	2/2008	Saito
D446,175 S	8/2001	Hoyle, Jr.	D563,281 S	3/2008	Simons et al.
D447,099 S	8/2001	Tirey et al.	D563,849 S	3/2008	Medina et al.
D450,277 S	11/2001	Onopa	D563,850 S	3/2008	Rosen et al.
D452,464 S	12/2001	Beigel	D563,851 S	3/2008	Rosen et al.
D455,381 S	4/2002	Maher	D563,852 S	3/2008	Rosen et al.
D460,023 S	7/2002	Beigel	D563,853 S	3/2008	Rosen et al.
D465,211 S	11/2002	Lawrence	D564,427 S	3/2008	Beigel et al.
D465,749 S	11/2002	Beigel	D566,635 S	4/2008	Rosen et al.
D466,450 S	12/2002	Maher et al.	D567,355 S	4/2008	Zakula et al.
D478,300 S	8/2003	Chiang	D571,696 S	6/2008	Rosen et al.
D479,166 S	9/2003	Tanaka et al.	D575,688 S	8/2008	Miyata et al.
D482,993 S	12/2003	Conway et al.	D577,316 S	9/2008	Rosen et al.
D484,077 S	12/2003	Conway et al.	D578,453 S	10/2008	Raghavendran et al.
D486,102 S	2/2004	Perfetti et al.	D580,312 S	11/2008	Opfer et al.
D488,112 S	4/2004	Satou	D582,716 S	12/2008	Averty
D490,749 S	6/2004	Satou	D588,512 S	3/2009	Raghavendran et al.
D491,858 S	6/2004	Velazco	D591,209 S	4/2009	Camacho et al.
D492,801 S	7/2004	Metros et al.	D592,561 S	5/2009	Otto et al.
D492,921 S	7/2004	Perfetti et al.	D592,574 S	5/2009	Larson
D493,759 S	8/2004	Pfeiffer	D597,003 S	7/2009	Yamazaki et al.
D494,514 S	8/2004	Pfeiffer	D601,932 S	10/2009	Rosen et al.
D494,900 S	8/2004	Satou	D604,209 S	11/2009	Chae
D495,633 S	9/2004	Chiang	D605,986 S	12/2009	Raghavendran et al.
D496,890 S	10/2004	Metros et al.	D606,339 S	12/2009	Jacobson et al.
D497,581 S	10/2004	Conway et al.	7,677,650 B2	3/2010	Huttenlocher
D498,186 S	11/2004	Iwai	D617,693 S	6/2010	Klobe
D502,897 S	3/2005	Delashaw et al.	D618,057 S	6/2010	Ormrod et al.
D502,901 S	3/2005	Delashaw et al.	D619,941 S	7/2010	Krauss
D502,904 S	3/2005	Delashaw et al.	D621,754 S	8/2010	Angelo
D504,642 S	5/2005	Perfetti et al.	D622,188 S	8/2010	Angelo et al.
D511,727 S	11/2005	Shaw et al.	D627,692 S	11/2010	Cheng
D512,666 S	12/2005	Chiang	D631,800 S	2/2011	Peltola et al.
			D632,224 S	2/2011	Peltola et al.
			D632,234 S	2/2011	Peltola et al.
			D634,093 S	3/2011	Wagner
			D635,567 S *	4/2011	Rashid ..... D14/341



(56)

References Cited

U.S. PATENT DOCUMENTS

D635,897 S 4/2011 Frei et al.  
 7,922,235 B1 4/2011 Smith  
 D640,175 S 6/2011 Villamizar et al.  
 D643,352 S 8/2011 Hjorten et al.  
 D645,797 S 9/2011 Beigel et al.  
 D647,016 S 10/2011 Medina et al.  
 D647,827 S 11/2011 Medina et al.  
 D647,832 S 11/2011 Medina et al.  
 D650,781 S \* 12/2011 Rashid ..... D14/341  
 D651,142 S 12/2011 Fushimi  
 D654,401 S 2/2012 Peltola et al.  
 D654,417 S 2/2012 Peltola et al.  
 D655,226 S 3/2012 Hanson et al.  
 D656,435 S 3/2012 Lambri et al.  
 D669,303 S 10/2012 Garman  
 D671,938 S \* 12/2012 Hsu ..... D14/341  
 D683,668 S 6/2013 Thurber  
 D685,294 S 7/2013 Hanson et al.  
 D686,122 S 7/2013 Peltola et al.  
 D690,242 S 9/2013 Conway et al.  
 D690,632 S 10/2013 Peltola et al.  
 D691,072 S 10/2013 Cheng  
 D692,805 S 11/2013 Morioka  
 D699,650 S 2/2014 Peltola et al.  
 D699,651 S 2/2014 Peltola et al.  
 D702,609 S 4/2014 Hovind et al.  
 D702,615 S 4/2014 Conway et al.  
 D706,577 S 6/2014 Funnell, II et al.  
 D706,690 S 6/2014 Peltola et al.  
 D707,160 S 6/2014 Peltola et al.  
 D707,161 S 6/2014 Peltola et al.  
 D707,163 S 6/2014 Peltola et al.  
 D708,104 S 7/2014 Conway et al.  
 D708,553 S 7/2014 Conway et al.  
 D708,985 S 7/2014 Peltola et al.  
 D708,986 S 7/2014 Conway et al.  
 D708,989 S 7/2014 Peltola et al.  
 D708,990 S 7/2014 Conway et al.  
 D708,992 S 7/2014 Ito et al.  
 D708,999 S 7/2014 Conway et al.  
 D709,000 S 7/2014 Peltola et al.  
 D709,001 S 7/2014 Conway et al.  
 D709,406 S 7/2014 Conway et al.  
 D709,407 S 7/2014 Conway et al.  
 D709,408 S 7/2014 Peltola et al.  
 D709,410 S 7/2014 Conway et al.  
 D709,411 S 7/2014 Peltola et al.  
 D709,421 S 7/2014 Conway et al.  
 D709,422 S 7/2014 Peltola et al.  
 D709,423 S 7/2014 Peltola et al.  
 D709,424 S 7/2014 Conway et al.  
 D709,425 S 7/2014 Conway et al.  
 D709,727 S 7/2014 Cloutier et al.  
 D710,765 S 8/2014 Conway et al.  
 D711,789 S 8/2014 Sahara et al.  
 8,800,703 B2 8/2014 Miller et al.  
 D714,195 S 9/2014 Conway et al.  
 D722,934 S 2/2015 Conway et al.  
 D729,705 S 5/2015 Gunnarson et al.  
 D729,709 S 5/2015 Conway et al.  
 D742,873 S \* 11/2015 Ahn ..... D14/341  
 D746,200 S 12/2015 Leetz  
 D751,470 S 3/2016 Buck et al.  
 D756,855 S 5/2016 Leetz et al.  
 D758,253 S 6/2016 Brzustowicz et al.  
 D759,550 S \* 6/2016 Vena ..... D12/163  
 D759,800 S 6/2016 Adrian et al.  
 D770,335 S 11/2016 Walterscheid et al.  
 D777,615 S \* 1/2017 Hanson ..... D12/163  
 D781,188 S 3/2017 Wolff et al.  
 D782,381 S 3/2017 Conway et al.  
 D784,077 S 4/2017 Zemel et al.  
 D786,742 S \* 5/2017 Ito ..... D12/163  
 D787,384 S 5/2017 Ito et al.  
 D787,476 S \* 5/2017 Lee ..... D14/218

D789,147 S 6/2017 Nilssen  
 D793,384 S \* 8/2017 Park ..... D14/341  
 D795,761 S 8/2017 Ito et al.  
 D799,677 S 10/2017 Jonas et al.  
 D803,730 S \* 11/2017 Ito ..... D12/163  
 D805,981 S 12/2017 Conway et al.  
 D807,798 S \* 1/2018 Piscitelli ..... D12/163  
 D826,931 S \* 8/2018 Chang ..... D14/341  
 D835,011 S \* 12/2018 Peltola ..... D12/163  
 D840,880 S \* 2/2019 Beaven ..... D12/163  
 2003/0179541 A1 \* 9/2003 Sullivan ..... G06F 1/1616  
 361/679.29  
 2013/0025954 A1 1/2013 Miller et al.

FOREIGN PATENT DOCUMENTS

CN 103423850 A 12/2013  
 CN 205971189 U 2/2017  
 CN 206131375 U 4/2017  
 DE 10238445 A1 3/2004  
 EP 3199395 A1 8/2017  
 GB 2513202 A 10/2014  
 JP 2009-83740 A 4/2009

OTHER PUBLICATIONS

“T270 Class 6 and T370 Class 7,” Kenworth Truck Company, Kirkland, Washington, 2008, 6-page brochure.  
 “T270 Class 6 and T370 Class 7,” Kenworth Truck Company, Kirkland, Washington, 2009, 6-page brochure.  
 “T300,” Kenworth Truck Company, Kirkland, Washington, 1994, 4-page brochure.  
 “T300,” Kenworth Truck Company, Kirkland, Washington, 1997, 5-page brochure.  
 “T300,” Kenworth Truck Company, Kirkland, Washington, 2001, 16-page brochure.  
 “T300,” Kenworth Truck Company, Kirkland, Washington, 2005, 16-page brochure.  
 “T400B and T450B,” Kenworth Truck Company, Kirkland, Washington, 1992, 10-page brochure.  
 “T440,” Kenworth Truck Company, Kirkland, Washington, 2010, 2-page brochure.  
 “T440,” Kenworth Truck Company, Kirkland, Washington, 2010, 6-page brochure.  
 “T470,” Kenworth Truck Company, Kirkland, Washington, 2010, 6-page brochure.  
 “T470H,” Kenworth Truck Company, Kirkland, Washington, 2009, 2-page brochure.  
 “T600,” Kenworth Truck Company, Kirkland, Washington, 1996, 7-page brochure.  
 “T600,” Kenworth Truck Company, Kirkland, Washington, 2002, 28-page brochure.  
 “T600,” Kenworth Truck Company, Kirkland, Washington, 2005, 24-page brochure.  
 “T600, Ten Years of Innovation,” Kenworth Truck Company, Kirkland, Washington, 1995, 6-page brochure.  
 “T600A,” Kenworth Truck Company, Kirkland, Washington, 1985, 10-page brochure.  
 “T660,” Kenworth Truck Company, Kirkland, Washington, 2007, 36-page brochure.  
 “T660,” Kenworth Truck Company, Kirkland, Washington, 2009, 36-page brochure.  
 “T700,” Kenworth Truck Company, Kirkland, Washington, 2010, 6-page brochure.  
 “T800B,” Kenworth Truck Company, Kirkland, Washington, 1993, 8-page brochure.  
 “T800,” Kenworth Truck Company, Kirkland, Washington, 1996, 7-page brochure.  
 “T800,” Kenworth Truck Company, Kirkland, Washington, 2002, 32-page brochure.  
 “T800,” Kenworth Truck Company, Kirkland, Washington, 2003, 32-page brochure.  
 “T800,” Kenworth Truck Company, Kirkland, Washington, 2005, 28-page brochure.



(56)

**References Cited**

## OTHER PUBLICATIONS

- “T800,” Kenworth Truck Company, Kirkland, Washington, 2009, 28-page brochure.
- “The Working Class,” Peterbilt Motors Company, Newark, California, Sep. 1976, 6-page brochure.
- “The World’s Best,” Kenworth Truck Company, Kirkland, Washington, 1992, 12-page brochure.
- “Unibilt™ Cab Sleeper System,” Peterbilt Motors Company, Denton Texas, Aug. 1994, 6-page brochure.
- “W900,” Kenworth Truck Company, Kirkland, Washington, 1996, 7-page brochure.
- “W900,” Kenworth Truck Company, Kirkland, Washington, 2002, 32-page brochure.
- “W900,” Kenworth Truck Company, Kirkland, Washington, 2005, 28-page brochure.
- “W900,” Kenworth Truck Company, Kirkland, Washington, 2009, 28-page brochure.
- “W900L Aero Cab,” Kenworth Truck Company, Kirkland, Washington, 1994, 2-page brochure.
- “T680,” Kenworth Truck Company, Kirkland, Washington, 2013, 34-page brochure.
- “T680,” Kenworth Truck Company, Kirkland, Washington, 2016, 34-page brochure.
- “T880,” Kenworth Truck Company, Kirkland, Washington, 2017, 32-page brochure.
- “Model 579,” Peterbilt Motors Company, Denton, Texas, 2013, 13-page brochure.
- “Model 587,” Peterbilt Motors Company, Denton, Texas, 2011, 4-page brochure.
- “Medium-Duty,” Peterbilt Motors Company, Denton, Texas, 2013, 9-page brochure.
- “On-Highway,” Peterbilt Motors Company, Denton, Texas, 2013, 13-page brochure.
- “Vocational,” Peterbilt Motors Company, Denton, Texas, 2013, 11-page brochure.
- “1960 MG Magnette Mark III 4 Door (Rare Find!)—Sold, Sold, Sold!!!” Happy Carz.com, <<http://www.happycarz.com/showroom/1960-mg-magnette-mark-iii-4-door-rare-find/>>.
- “2-Pc RC1 Classic Design Mesh Grille,” CarID, <<https://www.carid.com/2011-dodge-ram-grill/royally-core-rc-classic-design-grilles-561858656.html>>.
- “AeroCab,” Kenworth Truck Company, Kirkland, Washington, 1993, 5-page brochure.
- “AeroCab,” Kenworth Truck Company, Kirkland, Washington, as early as 1995, 3-page brochure.
- “AG130 Front Air Suspension,” Kenworth Truck Company, Kirkland, Washington, 2008, 2-page brochure.
- “C500B,” Kenworth Truck Company, Kirkland, Washington, as early as 1990, 4-page brochure.
- “Cabovers,” Peterbilt Motors Company, Newark, California, as early as 2000, 7-page brochure.
- “Cartek Auto Billet Grilles and ABS Grille Shells,” Tuned By Matrix, <[http://www.tunedbymatrix.com/Auto\\_Shells/300.php](http://www.tunedbymatrix.com/Auto_Shells/300.php)>.
- “Class Pays, Construction Trucks,” Peterbilt Motors Company, Denton, Texas, Nov. 2003, 16-page brochure.
- “Class Pays, Ergonomic Dash,” Peterbilt Motors Company, Denton, Texas, Mar. 2000, 2-page brochure.
- “Class Pays,” Medium Duty, Peterbilt Motors Company, Denton, Texas, Sep. 2000, 12-page brochure.
- “Class Pays,” Peterbilt Motors Company, Denton, Texas, Nov. 1998, 10-page brochure.
- “Class Pays,” Peterbilt Motors Company, Denton, Texas, Sep. 1997, 10-page brochure.
- “Class Pays, Platinum Interior,” Peterbilt Motors Company, Denton, Texas, May 2005, 4-page brochure.
- “Class Pays, Refuse Trucks,” Peterbilt Motors Company, Denton, Texas, Sep. 2003, 2-page brochure.
- “Class Pays, Truck Models,” Peterbilt Motors Company, Denton, Texas, Mar. 2005, 24-page brochure.
- “Construction Trucks,” Canadian Kenworth Truck, Mississauga, Ontario, Canada, Jul. 1990, 16-page brochure.
- “Daimler will kill the Maybach brand in 2013 and replace it with S600 Pullman,” 4WheelsNews, Nov. 25, 2011, <<https://www.4wheelsnews.com/auto/daimler-will-kill-the-maybach-brand-in-2013-and-replace-it-with-s600-pullma-18746-g-60963.html>>.
- “Installing a Pines Winterfront Grille on a 1932 Ford Vicky,” Seabright Hot Rods, Sep. 5, 2016, <<http://www.seabrighthotrods.com/?p=718>>.
- “Interiors,” Kenworth Truck Company, Kirkland, Washington, 2005, 16-page brochure.
- “Jaguar XJ Series X300 Parts—Radiator Grille and Badges,” Jaguar Classic Parts, <<https://www.jaguarclassicparts.com/uk/jaguar-xj-x300-parts/exterior-fillings-and-sunroofgrilles/radiator-grille-and-badges>>.
- “K100E,” Kenworth Truck Company, Kirkland, Washington, 1984, 8-page brochure.
- “Kenworth Truck Models,” Kenworth Truck Company, Kirkland, Washington, 2010, 16-page brochure.
- “MGA Mesh Grille Conversion Kit,” The MG Experience, Apr. 20, 2009, <<http://www.mgexp.com/phorum/read.php?2,1089209>>.
- “Model 320,” Peterbilt Motors Company, Denton, Texas, May 1996, 2-page brochure.
- “Model 330,” Peterbilt Motors Company, Denton, Texas, Oct. 1997, 3-page brochure.
- “Model 357 Heavy Haul,” Peterbilt Motors Company, Denton, Texas, Mar. 2005, 2-page brochure.
- “Model 357 Standard Specifications,” Peterbilt Motors Company, Newark, California, Sep. 1986, 5-page brochure.
- “Model 357, New Sloped Hood,” Peterbilt Motors Company, Denton, Texas, May 2002, 2-page brochure.
- “Model 357,” Peterbilt Motors Company, Denton, Texas, May 1994, 3-page brochure.
- “Model 357-115,” Peterbilt Motors Company, Denton, Texas, Mar. 2005, 2-page brochure.
- “Model 362,” Peterbilt Motors Company, Newark, California, 1985, 8-page brochure.
- “Model 375 Standard Specifications,” Peterbilt Motors Company, Newark, California, Sep. 1986, 6-page brochure.
- “Model 377A/E,” Peterbilt Motors Company, Denton, Texas, Aug. 1997, 2-page brochure.
- “Model 377A/E,” Peterbilt Motors Company, Denton, Texas, Jan. 1995, 6-page brochure.
- “Model 378,” Peterbilt Motors Company, Denton, Texas, Mar. 1998, 3-page brochure.
- “Model 379,” Peterbilt Motors Company, Denton, Texas, Apr. 2005, 2-page brochure.
- “Model 379,” Peterbilt Motors Company, Denton, Texas, Mar. 1996, 5-page brochure.
- “Model 385,” Peterbilt Motors Company, Denton, Texas, Oct. 1996, 5-page brochure.
- “Model 387,” Peterbilt Motors Company, Denton, Texas, Oct. 2002, 2-page brochure.
- “PACCAR Engines, 2010 Medium Duty Engines,” PACCAR Inc, Bellevue, Washington, 2010, 6-page brochure.
- “PACCAR MX,” PACCAR Inc, Bellevue, Washington, 2010, 4-page brochure.
- “Peterbilt Brochure,” Feb. 2011, <<http://web.archive.org/web/20060212234257/http://www.peterbilt.com/Full-line.htm>> [retrieved Nov. 22, 2013].
- “Peterbilt Parts & Accessories,” Peterbilt Motors Company, Denton, Texas, catalog, as early as 2000, 52-page brochure.
- “Rest with Class,” Peterbilt Motors Company, Newark, California, Apr. 1978, 4-page brochure.
- “Studio Sleeper,” Kenworth Truck Company, Kirkland, Washington, 1993, 5-page brochure.
- “T170 Class 5,” Kenworth Truck Company, Kirkland, Washington, 2008, 4-page brochure.
- “T2000,” Kenworth Truck Company, Kirkland, Washington, 1999, 20-page brochure.
- “T2000,” Kenworth Truck Company, Kirkland, Washington, 2002, 20-page brochure.

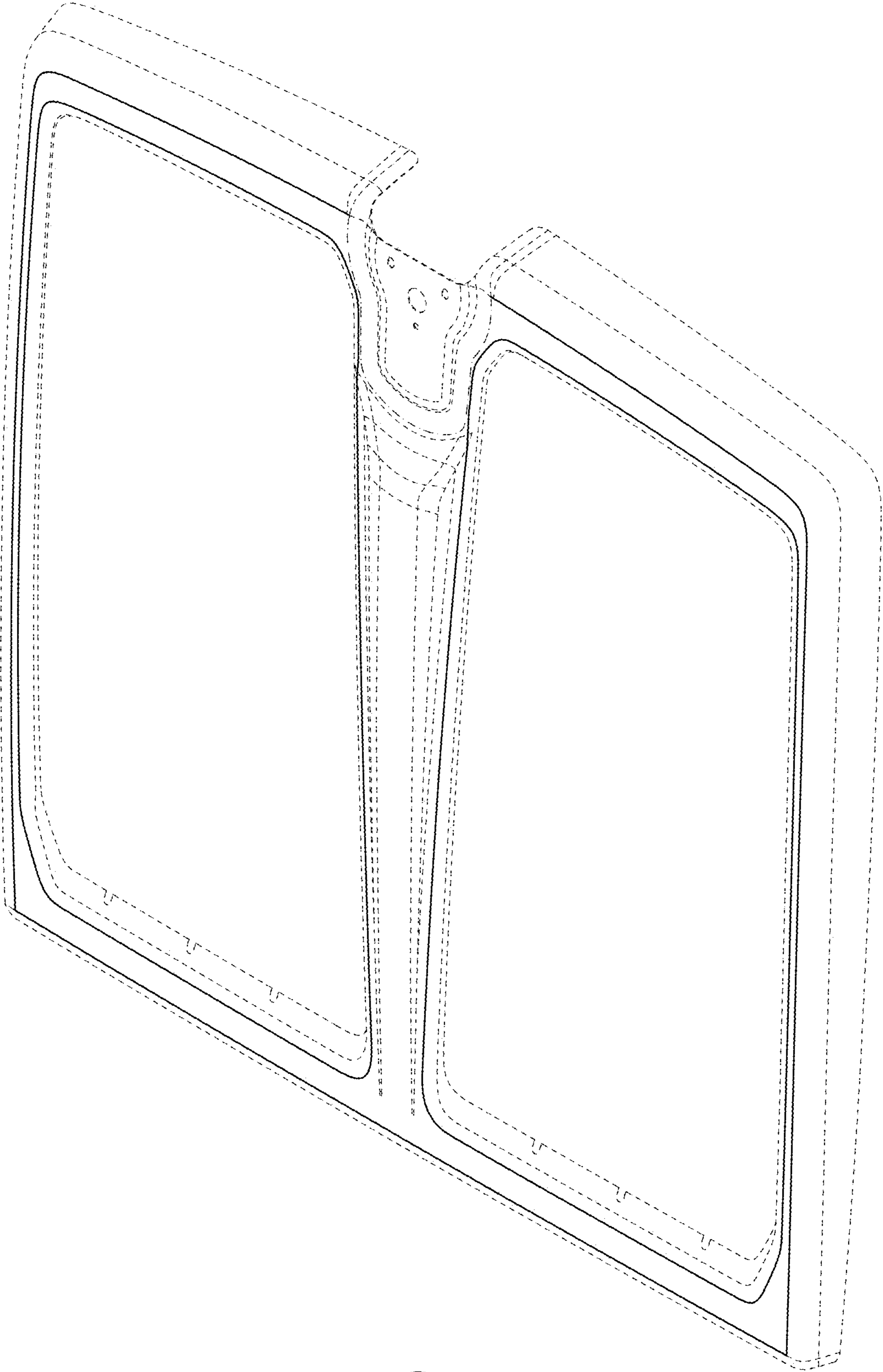
(56)

**References Cited**

OTHER PUBLICATIONS

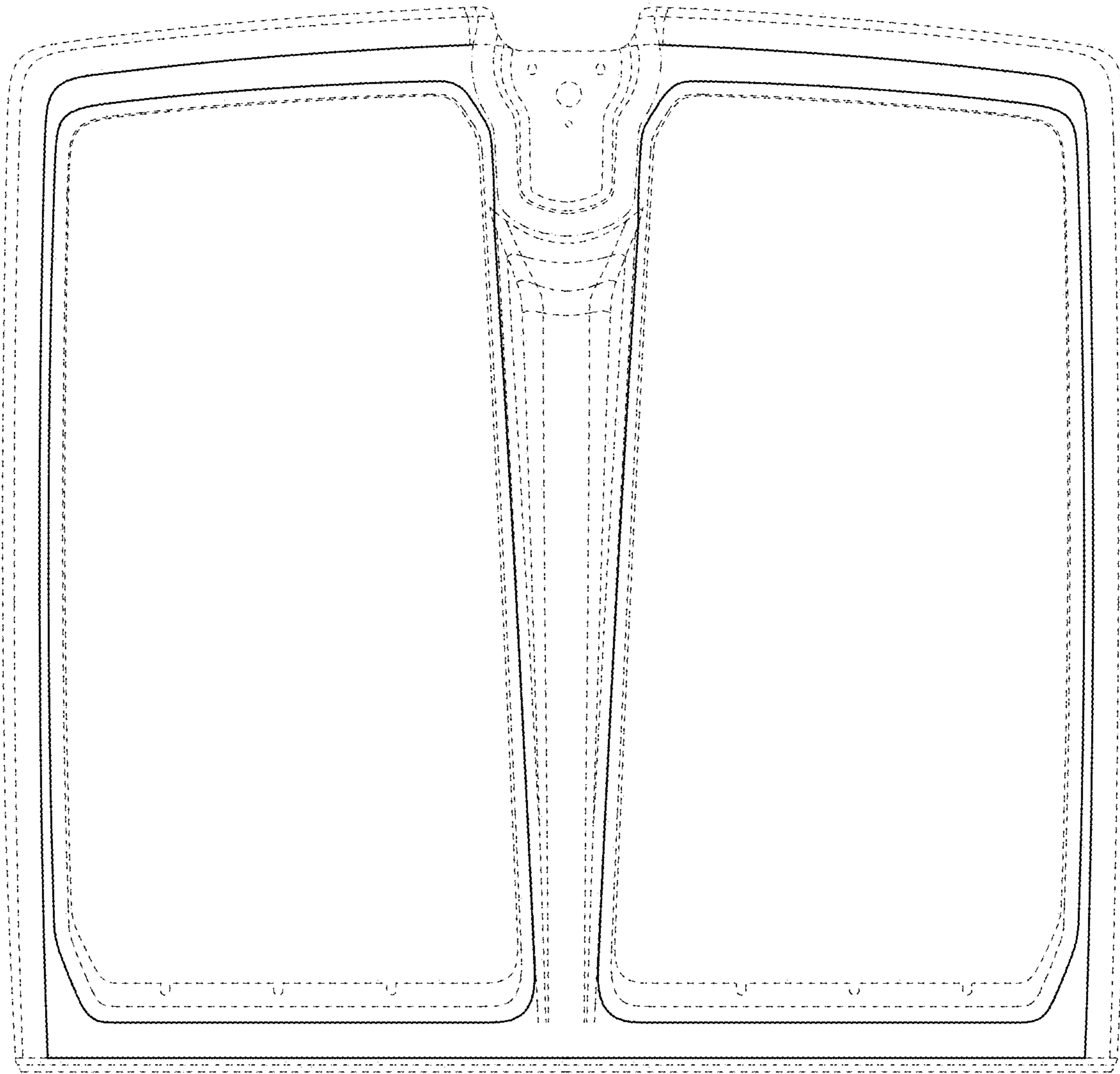
"T2000," Kenworth Truck Company, Kirkland, Washington, 2005,  
20-page brochure.

\* cited by examiner



*Fig. 1.*

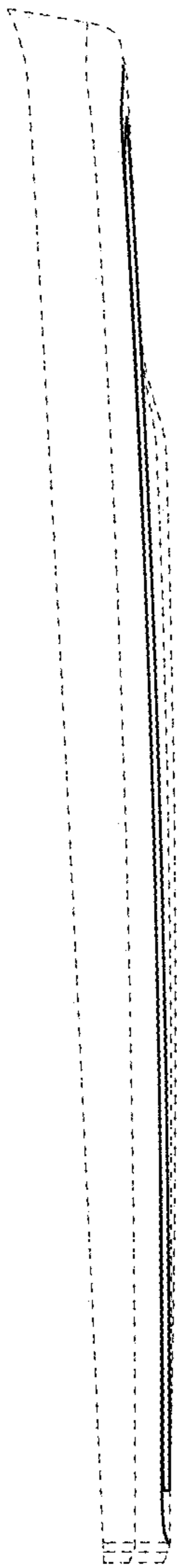




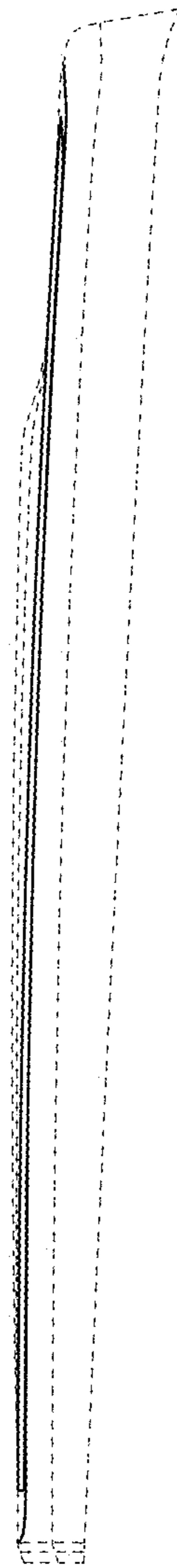
*Fig. 2.*



*Fig. 3.*



*Fig. 4.*



*Fig. 5.*