



US00D906582S

(12) **United States Design Patent**
Trzeciński

(10) **Patent No.:** **US D906,582 S**

(45) **Date of Patent:** **** *Dec. 29, 2020**

(54) **HOUSING FOR A LED-BASED LIGHTING APPARATUS**

(71) Applicant: **LED Labs sp. zoo**, Cracow (PL)

(72) Inventor: **Grzegorz Trzeciński**, Cracow (PL)

(73) Assignee: **LED Labs sp. z o.o**, Cracow (PL)

(*) Notice: This patent is subject to a terminal disclaimer.

(**) Term: **15 Years**

(21) Appl. No.: **29/661,254**

(22) Filed: **Aug. 26, 2018**

(51) **LOC (12) Cl.** **26-05**

(52) **U.S. Cl.**
USPC **D26/138**

(58) **Field of Classification Search**
USPC D26/61, 62, 63, 64, 65, 66, 71, 72, 73,
D26/74, 75, 87, 89, 76, 78, 79, 80, 81,
D26/82, 83, 85, 86, 88, 90, 113, 118,
D26/119, 120, 121

CPC F21S 2/00; F21S 4/00; F21S 4/003; F21S
4/005; F21S 4/006; F21S 6/00; F21S
8/00; F21S 8/024

See application file for complete search history.

(56) **References Cited**

U.S. PATENT DOCUMENTS

D695,955 S * 12/2013 Klus D26/138
D731,704 S * 6/2015 Klus D26/138

D733,355 S * 6/2015 Klus D26/138
D775,409 S * 12/2016 Klus D26/138
D807,572 S * 1/2018 Klus D26/138
D818,188 S * 5/2018 Trzesniowski D26/138
D818,190 S * 5/2018 Trzesniowski D26/138
D818,194 S * 5/2018 Trzesniowski D26/138
D824,584 S * 7/2018 Klus D26/138
D847,412 S * 4/2019 Trzeciński D26/138
D868,353 S * 11/2019 Trzeciński D26/138
D869,070 S * 12/2019 Trzeciński D26/138
D869,073 S * 12/2019 Trzeciński D26/138
D869,076 S * 12/2019 Trzeciński D26/138
D869,080 S * 12/2019 Trzeciński D26/138
D875,299 S * 2/2020 Trzeciński D26/138

* cited by examiner

Primary Examiner — Mark A Goodwin

Assistant Examiner — Benjamin M Weeks

(74) *Attorney, Agent, or Firm* — Andrew Malarz, Esq.

(57) **CLAIM**

The ornamental design for a housing for a LED-based lighting apparatus as shown and described.

DESCRIPTION

FIG. 1 is a front, a left side perspective view of a housing for a LED-based lighting apparatus showing my new design; FIG. 2 is a front elevational view thereof; FIG. 3 is a top plan view thereof; FIG. 4 is a bottom plan view thereof; and, FIG. 5 is a right side elevational view thereof, the left side being a mirror image.

1 Claim, 5 Drawing Sheets

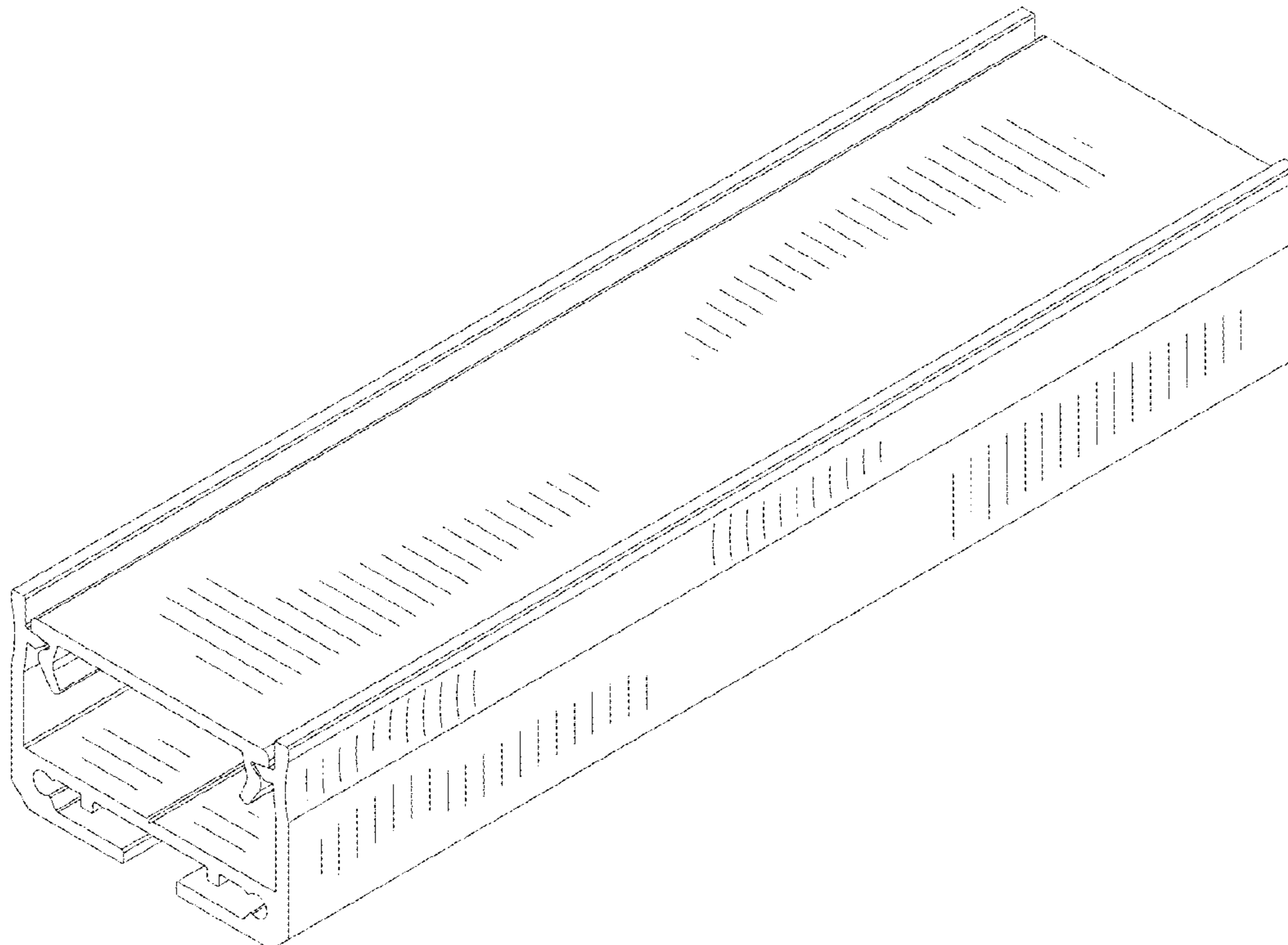

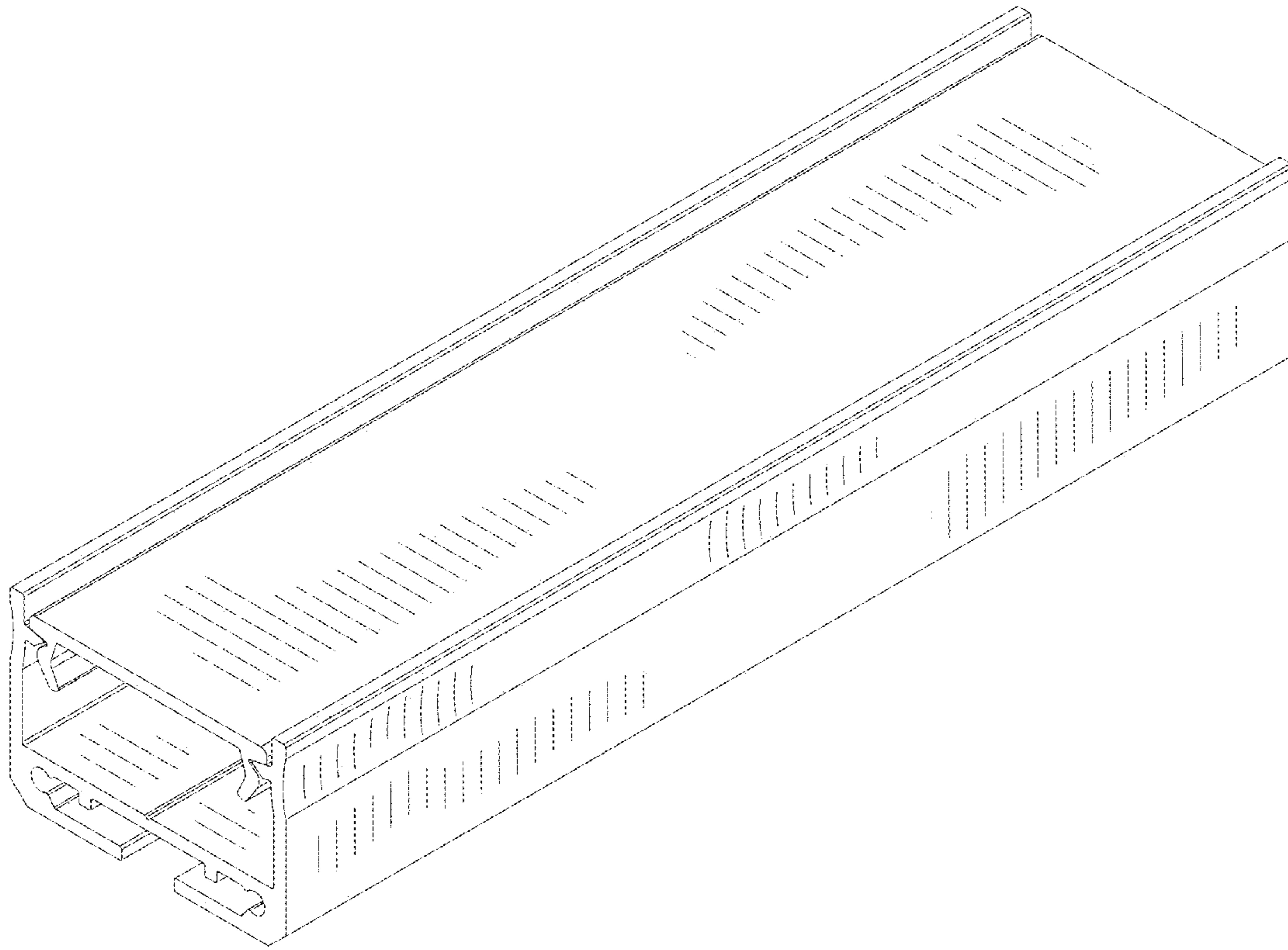

FIG. 1

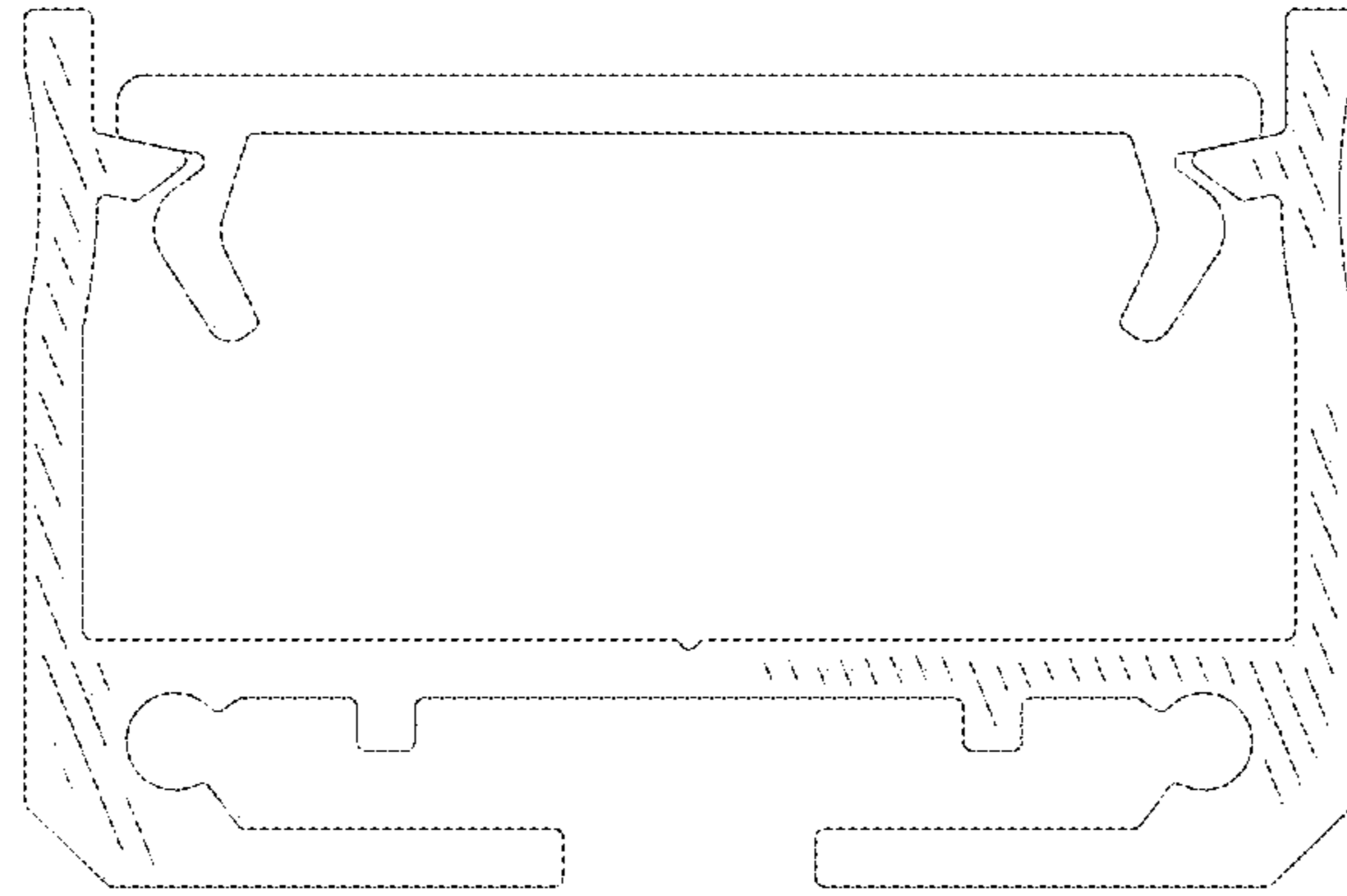

FIG. 2

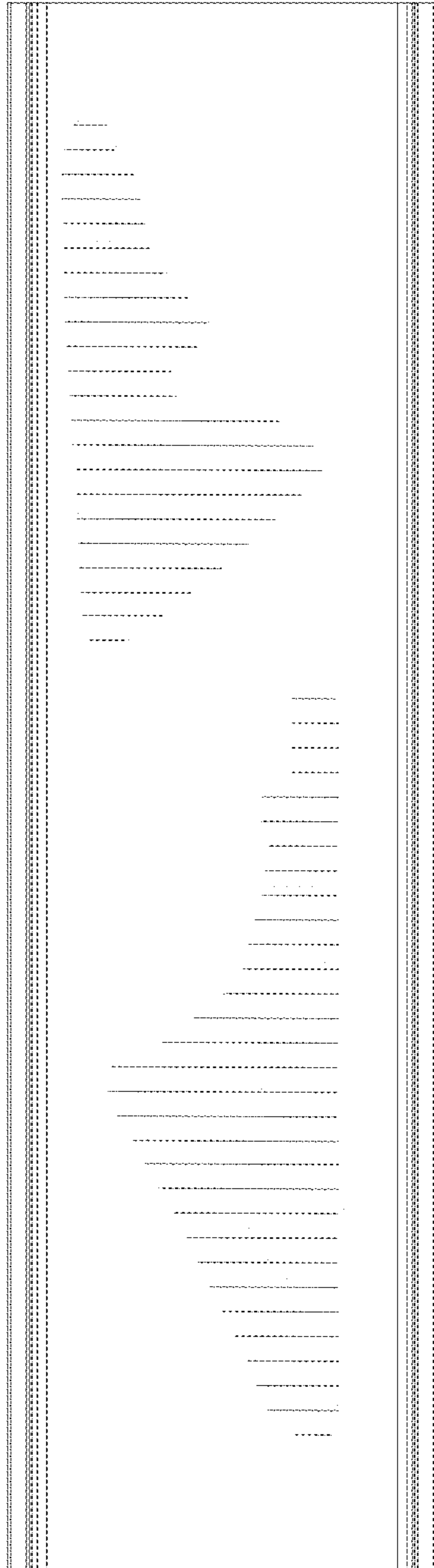

FIG. 3

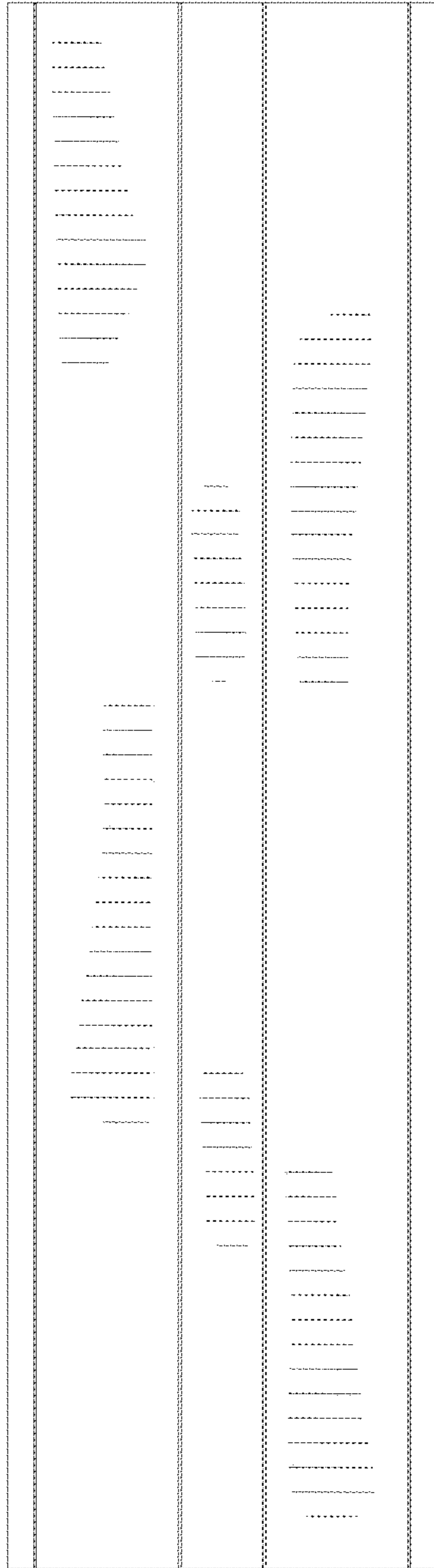

FIG. 4

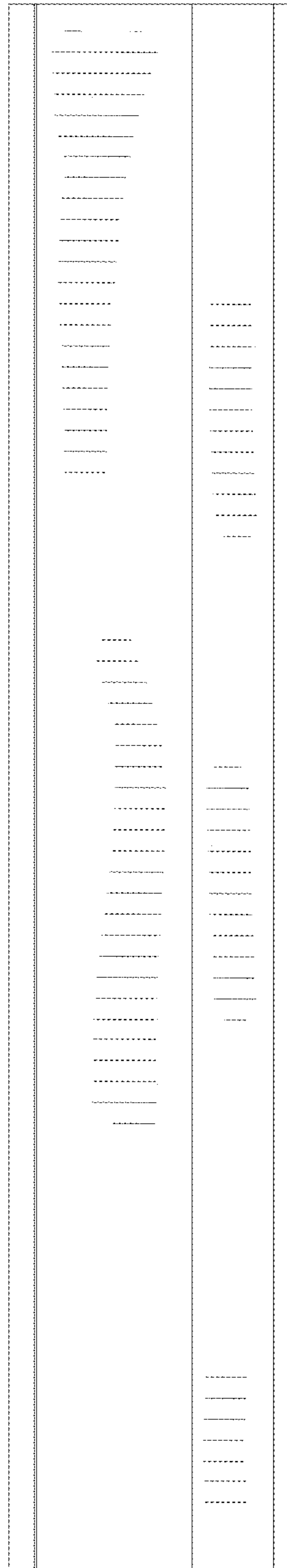

FIG. 5