



US00D906230S

(12) **United States Design Patent**
Sato et al.

(10) **Patent No.: US D906,230 S**
(45) **Date of Patent: ** Dec. 29, 2020**

(54) **TIRE**

FOREIGN PATENT DOCUMENTS

(71) Applicant: **TOYO TIRE & RUBBER CO., LTD.**,
Itami (JP)

JP 1071535 5/2000
JP 1122057 9/2001

(72) Inventors: **Yoshiki Sato**, Itami (JP); **Tetsuji Miyazaki**, Itami (JP)

OTHER PUBLICATIONS

(73) Assignee: **TOYO TIRE & RUBBER CO., LTD.**,
Itami (JP)

Press Release: "Uniroyal Tire Steals the Show with the Red Dot Award", RainSport 3, Apr. 4, 2014.

(Continued)

(**) Term: **15 Years**

Primary Examiner — George D. Kirschbaum

(21) Appl. No.: **29/659,072**

Assistant Examiner — Joseph J Kukella

(22) Filed: **Aug. 6, 2018**

(74) *Attorney, Agent, or Firm* — Sterne, Kessler, Goldstein & Fox P.L.L.C.

(30) **Foreign Application Priority Data**

(57) **CLAIM**

Feb. 7, 2018 (JP) 2018-002462

The ornamental design for a tire, as shown and described.

(51) **LOC (12) Cl.** **12-15**

(52) **U.S. Cl.**
USPC **D12/531**

DESCRIPTION

(58) **Field of Classification Search**

USPC D12/505-567
CPC B60C 11/0302; B60C 2011/0358; B60C
2011/0374; B60C 2011/0386; B60C
2011/0388

See application file for complete search history.

FIG. 1 is a front perspective view of a tire showing the claimed design;

FIG. 2 is a front view thereof;

FIG. 3 is a rear view thereof;

FIG. 4 is a top plan view thereof;

FIG. 5 is a bottom plan view thereof;

FIG. 6 is a right side view thereof;

FIG. 7 is a left side view thereof;

FIG. 8 is an enlarged view taken along line 8-8 in FIG. 1;

FIG. 9 is an enlarged view of the portion 9-9 in FIG. 2; and,

FIG. 10 is a cross-sectional view taken along line 10-10 in FIG. 9.

In the drawings, the broken lines defining the sidewall, inner bead and the peripheral boundary between the claimed tire tread and the unclaimed sidewall depict environmental subject matter that forms no part of the claimed design.

(56) **References Cited**

U.S. PATENT DOCUMENTS

6,439,286 B1 * 8/2002 Baumhofer B60C 19/001
152/209.8
D562,757 S * 2/2008 Iwai D12/519
D588,521 S * 3/2009 Tomatsu D12/519
D593,931 S * 6/2009 Fontaine D12/521
D603,784 S * 11/2009 Sareen D12/518
D701,822 S * 4/2014 Bindner D12/523
D720,681 S * 1/2015 Bindner B60C 19/001
D12/523

1 Claim, 10 Drawing Sheets

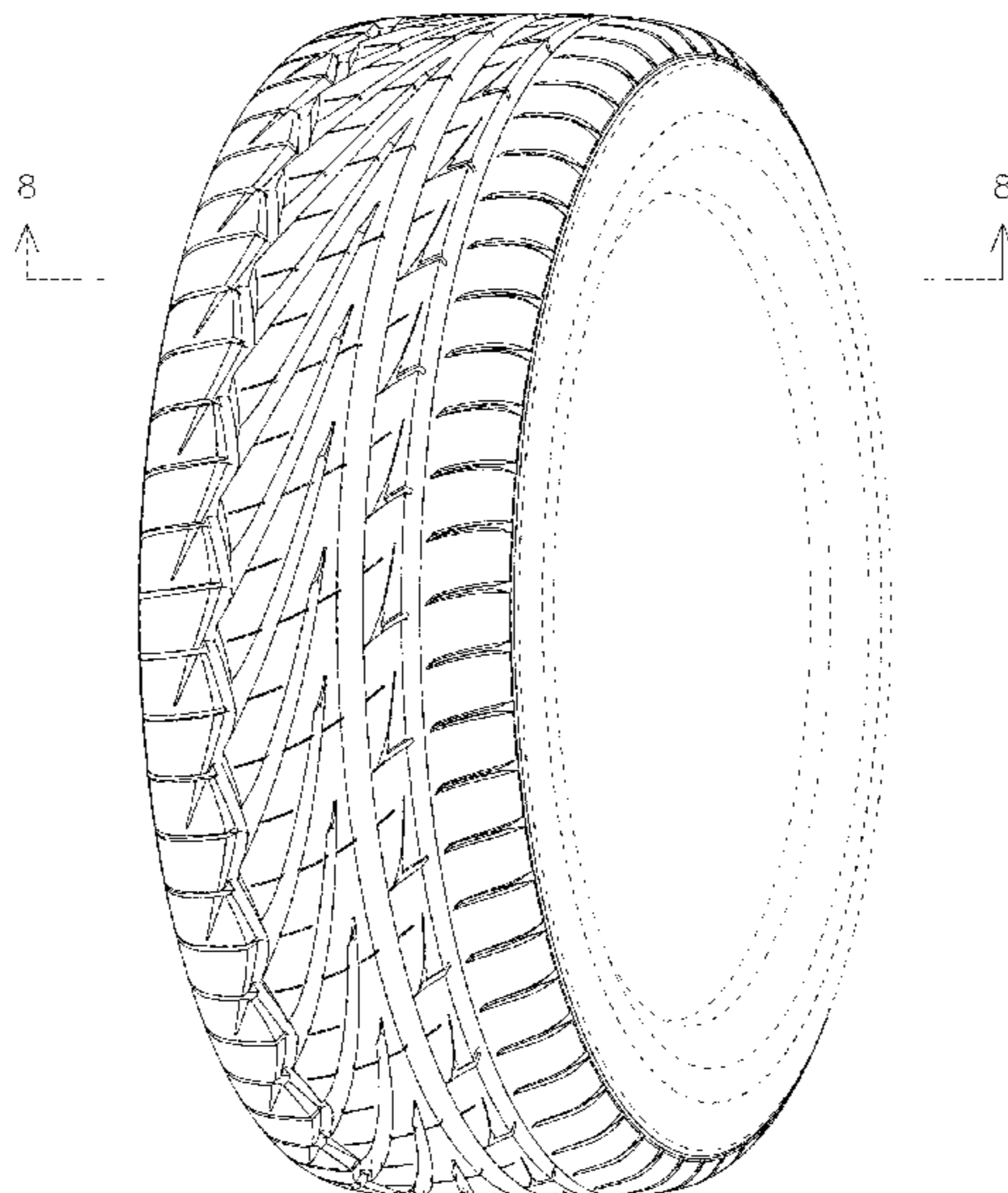

(56)

References Cited

OTHER PUBLICATIONS

“The Rain Tyre Uniroyal: RainSport3: The ultra high performance summer tyre”, retrieved from the Internet, <<https://www.uniroyal-tyres.com/car/tyres/rainsport-3>>, publication date as at least as early as Mar. 19, 2014.

“Uniroyal RainSport 3—225/45 R17 91Y—C/A/71—Summer Tyre (Passenger Car)”, retrieved from the internet, <<https://www.amazon.co.uk/dp/B00CJFWHAA>>, publication date as at least as early as Mar. 19, 2014.

* cited by examiner

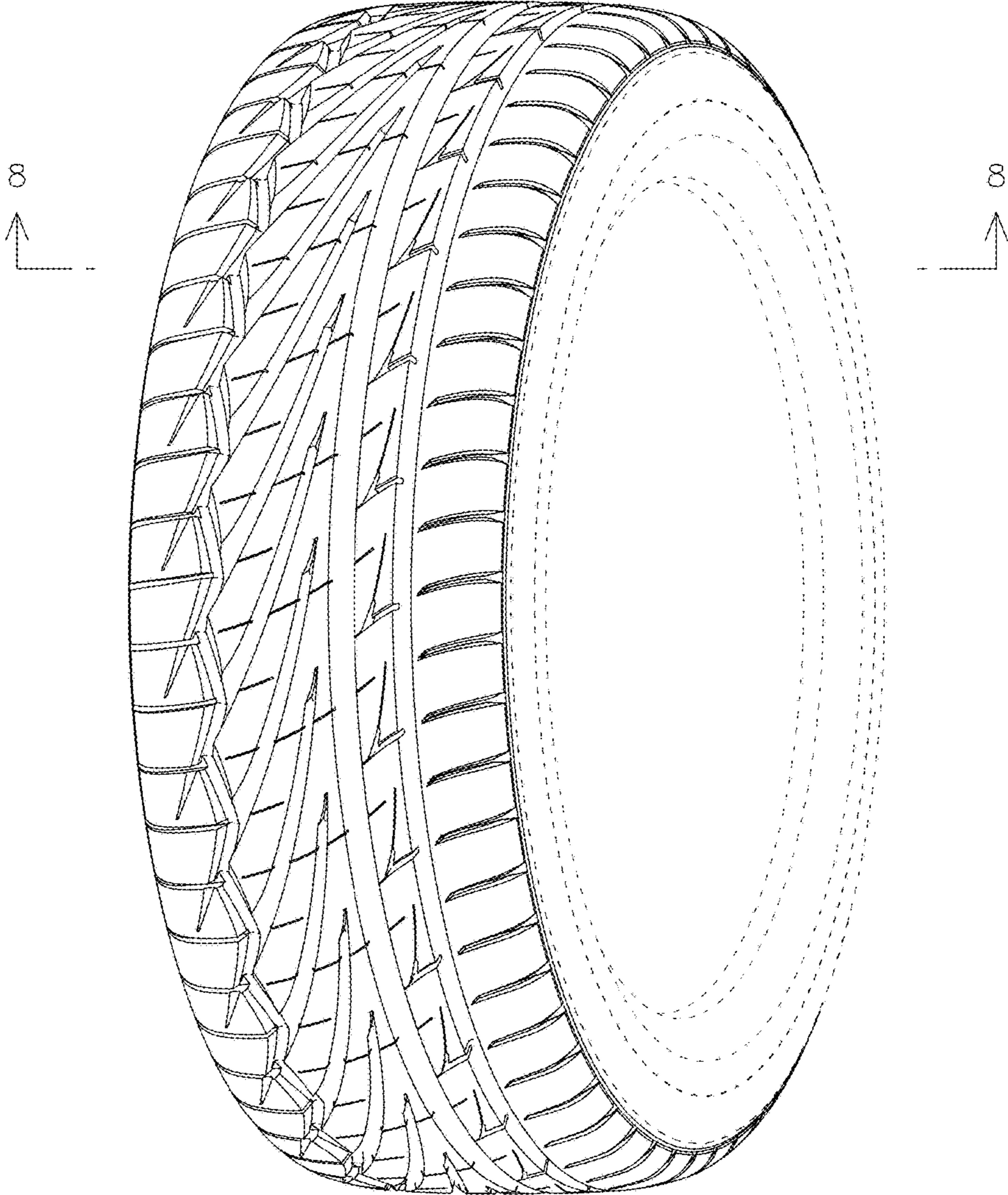

FIG. 1

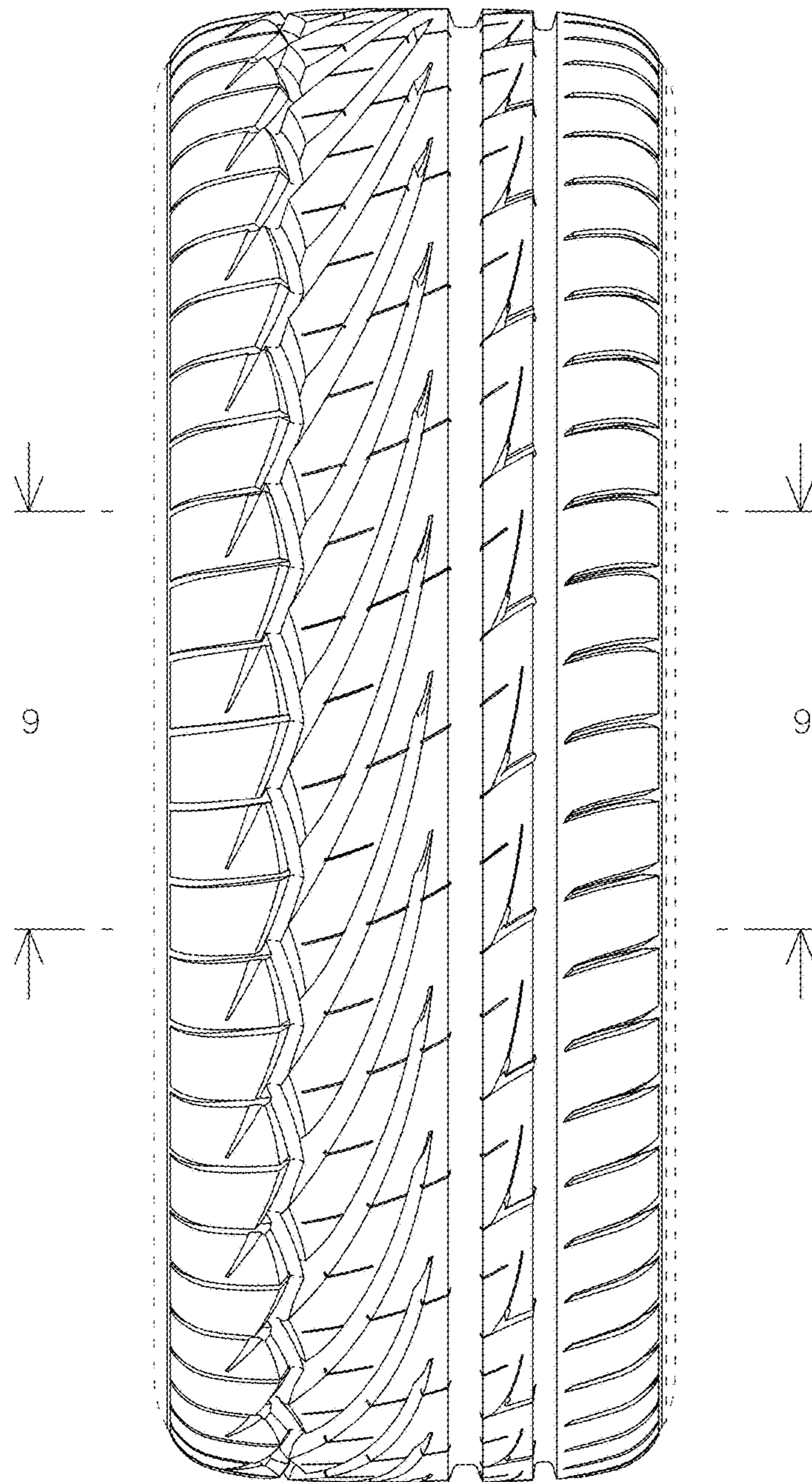

FIG. 2

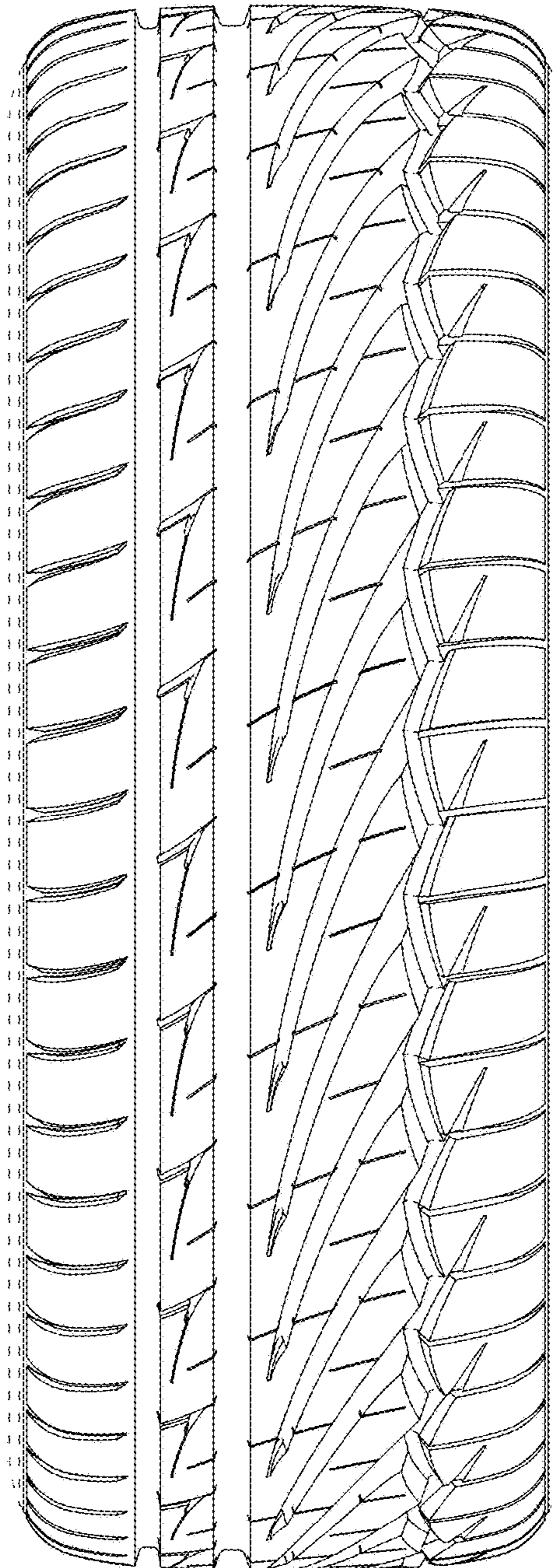

FIG. 3

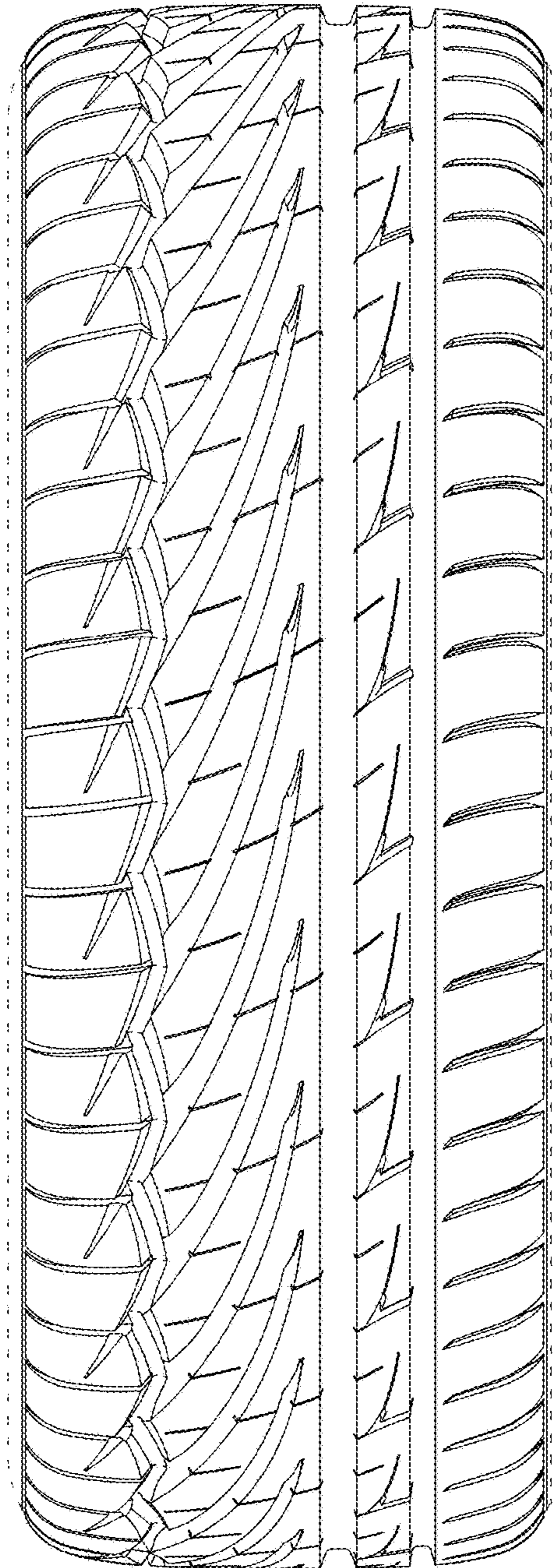

FIG. 4

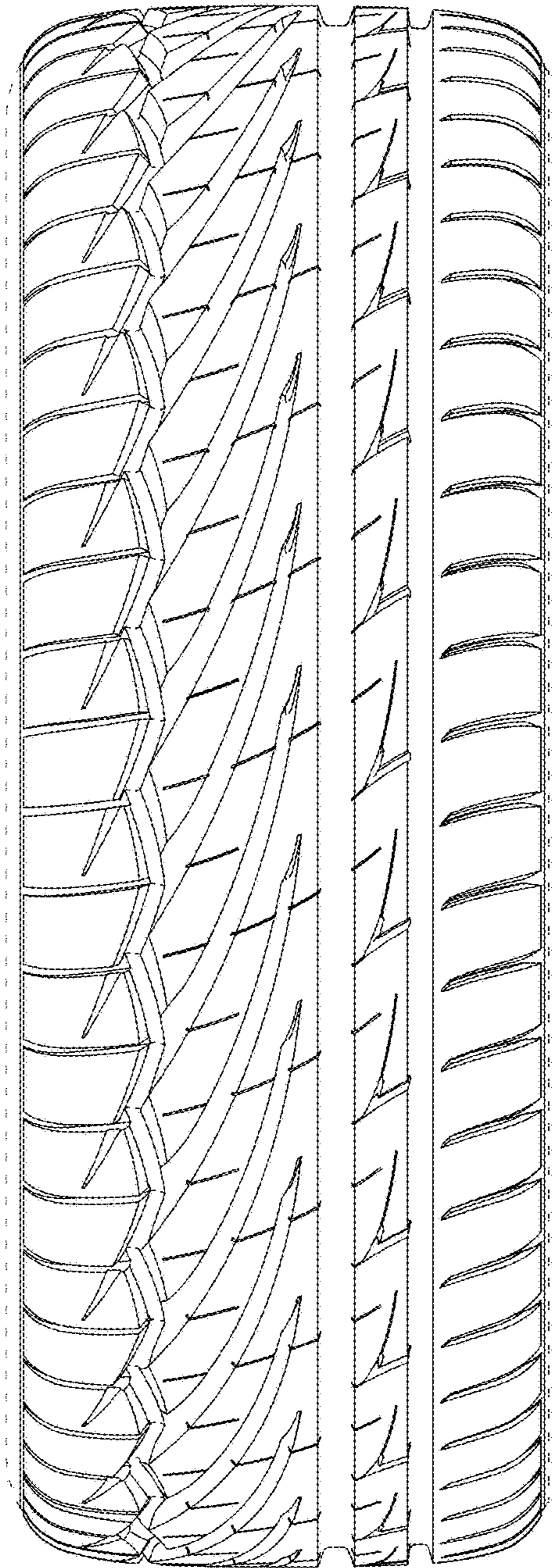

FIG. 5

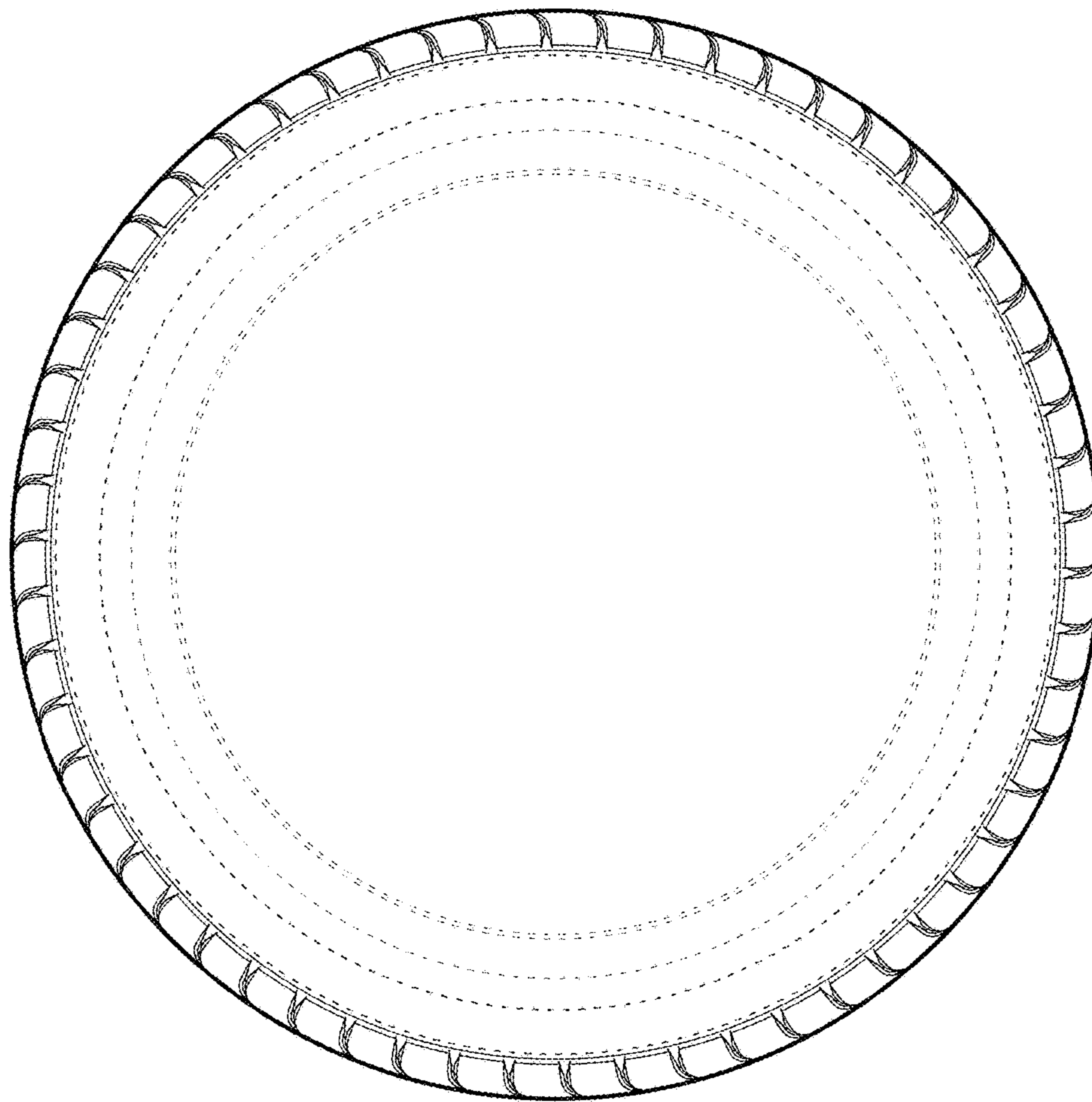

FIG. 6

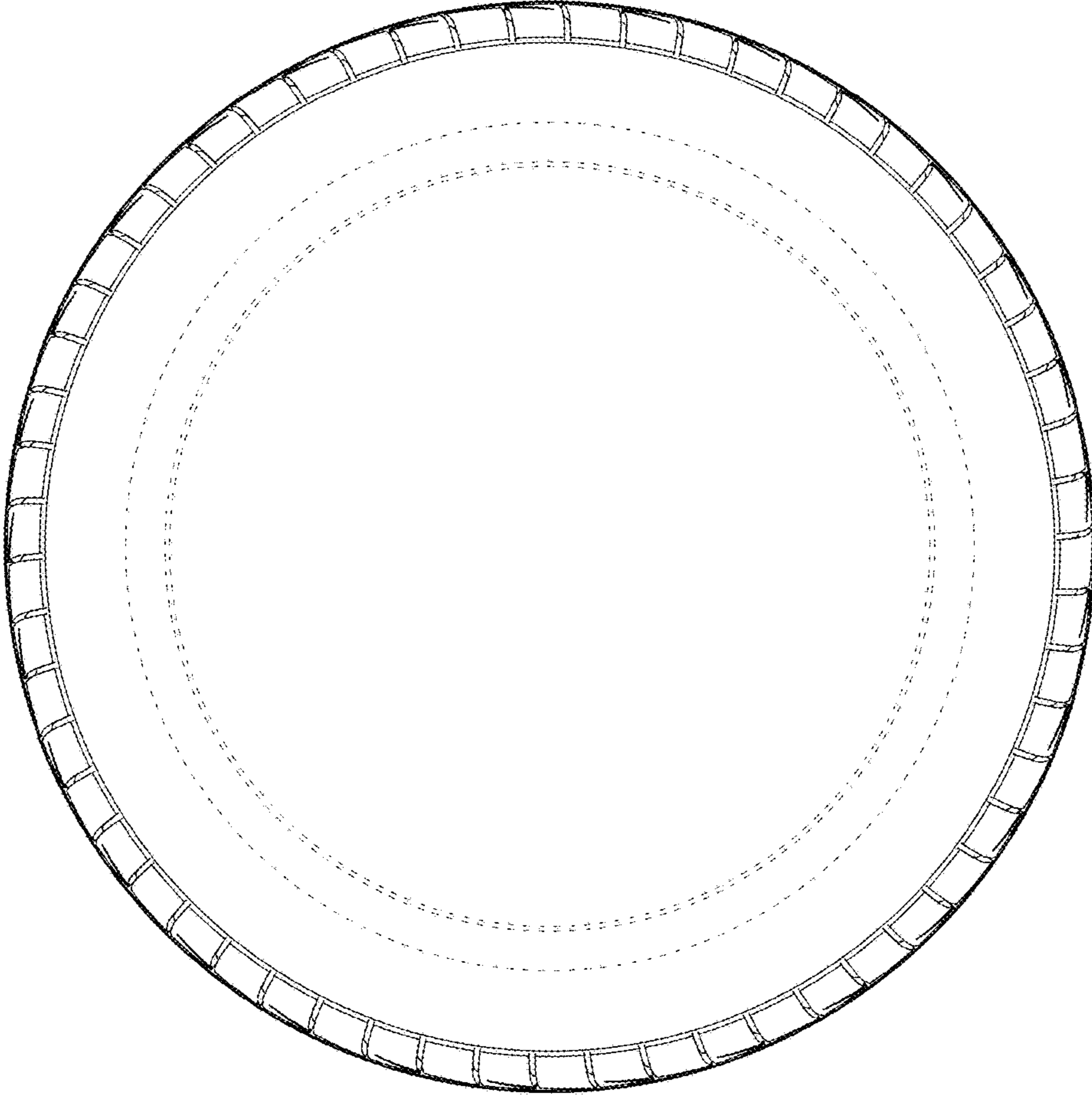

FIG. 7

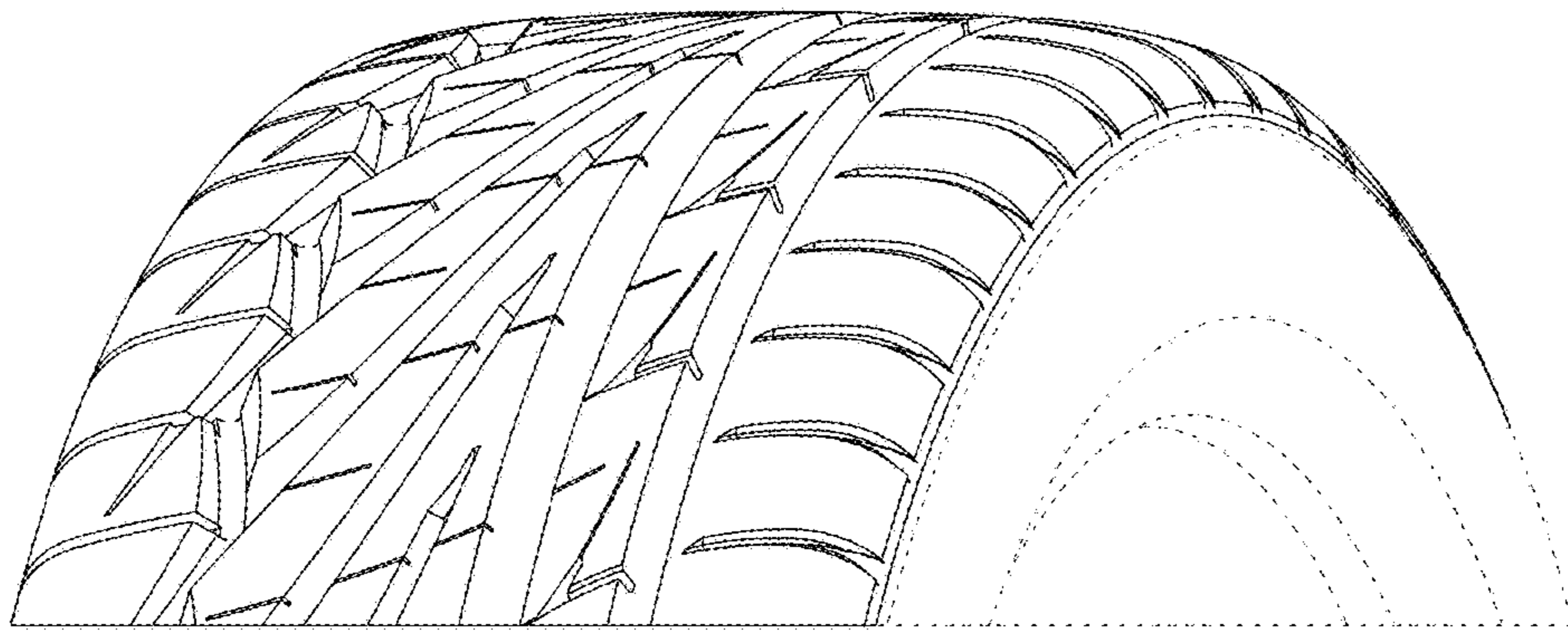

FIG. 8

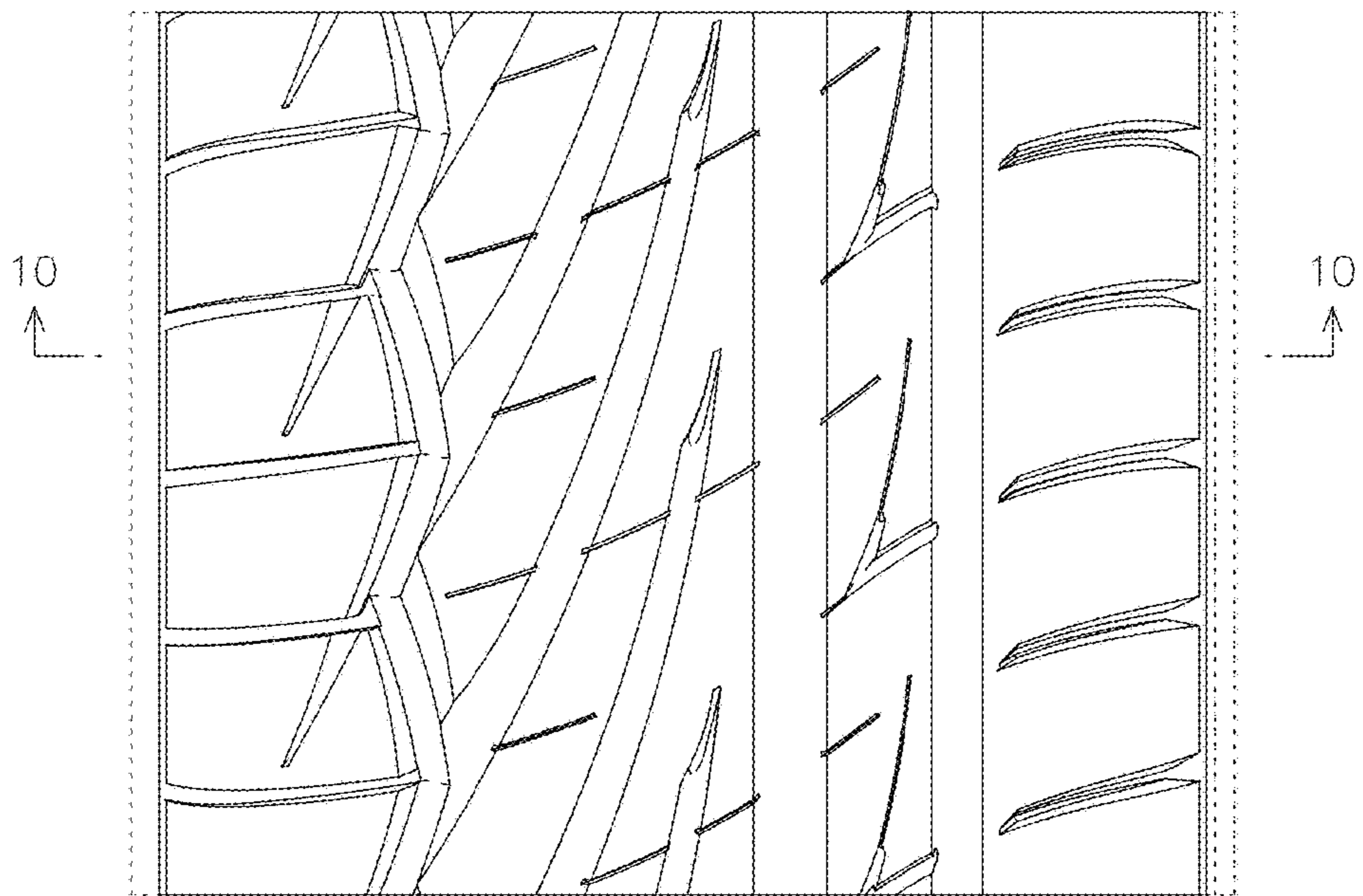

FIG. 9

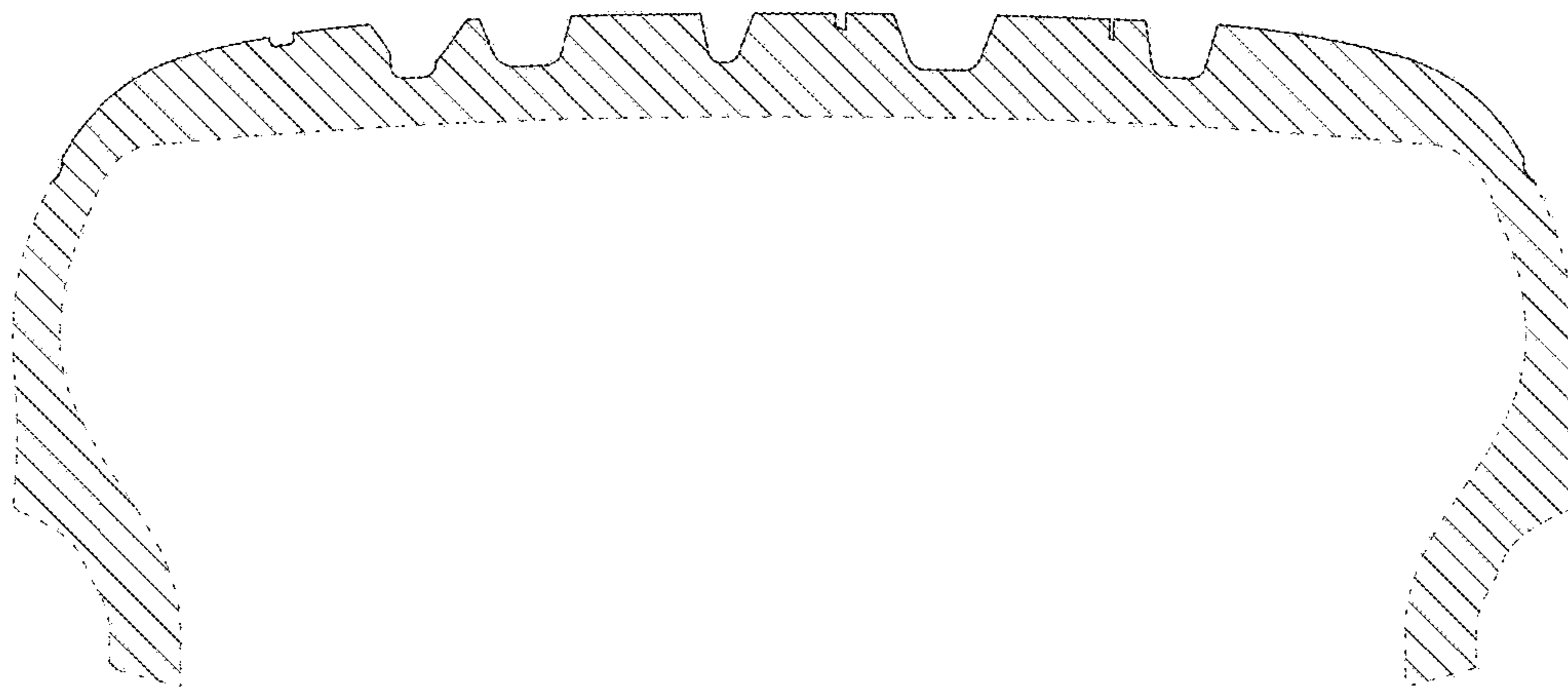

FIG. 10