



US00D906224S

(12) **United States Design Patent** (10) **Patent No.:** **US D906,224 S**
Kim et al. (45) **Date of Patent:** **** Dec. 29, 2020**

(54) **VEHICLE FRAME**
(71) Applicant: **Super73, Inc.**, Irvine, CA (US)
(72) Inventors: **John Kim**, Irvine, CA (US); **Aaron P. Wong**, Irvine, CA (US); **Legrand Crewse**, Irvine, CA (US)
(73) Assignee: **Super73, Inc.**, Irvine, CA (US)
(**) Term: **15 Years**
(21) Appl. No.: **29/655,285**
(22) Filed: **Jul. 2, 2018**
(51) **LOC (12) Cl.** **12-11**
(52) **U.S. Cl.**
USPC **D12/407**
(58) **Field of Classification Search**
USPC ... D12/115, 120, 407, 412, 413, 414, 414.1;
D3/304-306; D6/552
CPC B62J 7/00; B62J 7/02; B62J 7/04; B62J
7/08
See application file for complete search history.

5,505,490 A * 4/1996 Yun B60G 3/00
280/124.128
D392,247 S * 3/1998 Gogan D12/407
D395,420 S * 6/1998 Gogan D12/407
D395,628 S * 6/1998 Rougier D12/159
D397,189 S * 8/1998 Pierret D12/408
D427,963 S * 7/2000 Gogan D12/407
D575,722 S * 8/2008 Beauchamp D12/412
D690,618 S * 10/2013 Gordon D12/82
D719,904 S * 12/2014 Rickard D12/412
D735,635 S * 8/2015 Sonnentag D12/407
D817,854 S * 5/2018 Motherwell D12/407
D867,476 S * 11/2019 Wood D21/561
D875,848 S * 2/2020 Wood D21/561

* cited by examiner
Primary Examiner — Darlington Ly
(74) *Attorney, Agent, or Firm* — Stradling, Yocca,
Carlson & Rauth

(57) **CLAIM**
The ornamental design for a vehicle frame, as shown and described.

DESCRIPTION
FIG. 1 is a perspective view of a vehicle frame showing our new design;
FIG. 2 is a front elevation view thereof
FIG. 3 is a rear elevation view thereof;
FIG. 4 is a right side elevation view thereof;
FIG. 5 is a left side elevation view thereof;
FIG. 6 is a top plan view thereof; and,
FIG. 7 is a bottom plan view thereof.
The broken lines in the drawings illustrate portions of the vehicle frame that form no part of the claimed design.

1 Claim, 7 Drawing Sheets

(56) **References Cited**
U.S. PATENT DOCUMENTS
1,260,937 A * 3/1918 Muller, Jr. B62J 7/04
224/450
D264,233 S * 5/1982 Hundley D12/107
4,393,986 A * 7/1983 Sirey B62J 11/00
224/443
D312,229 S * 11/1990 Yun D12/111
D330,529 S * 10/1992 Yun D12/107
D330,530 S * 10/1992 Yun D12/107

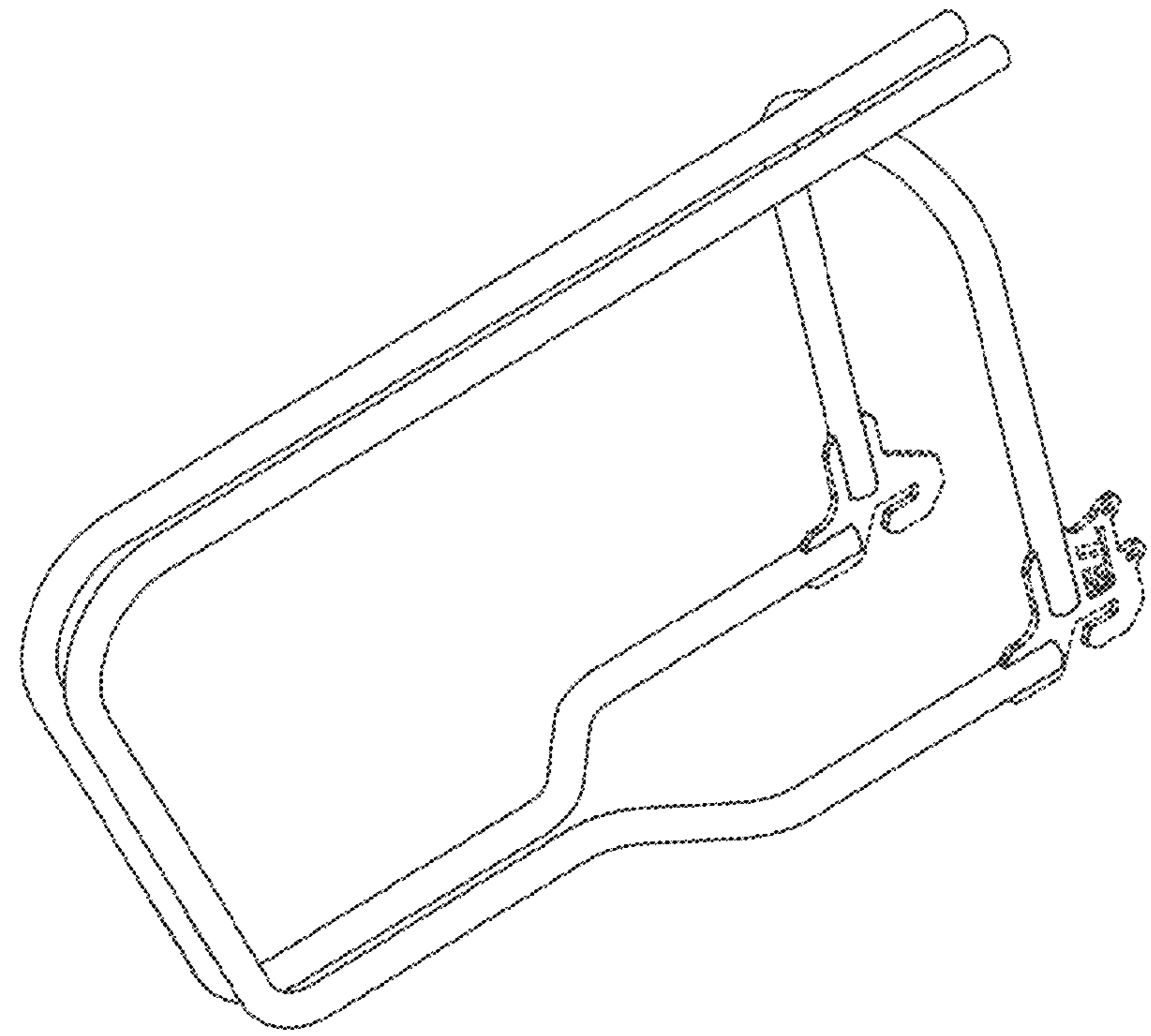

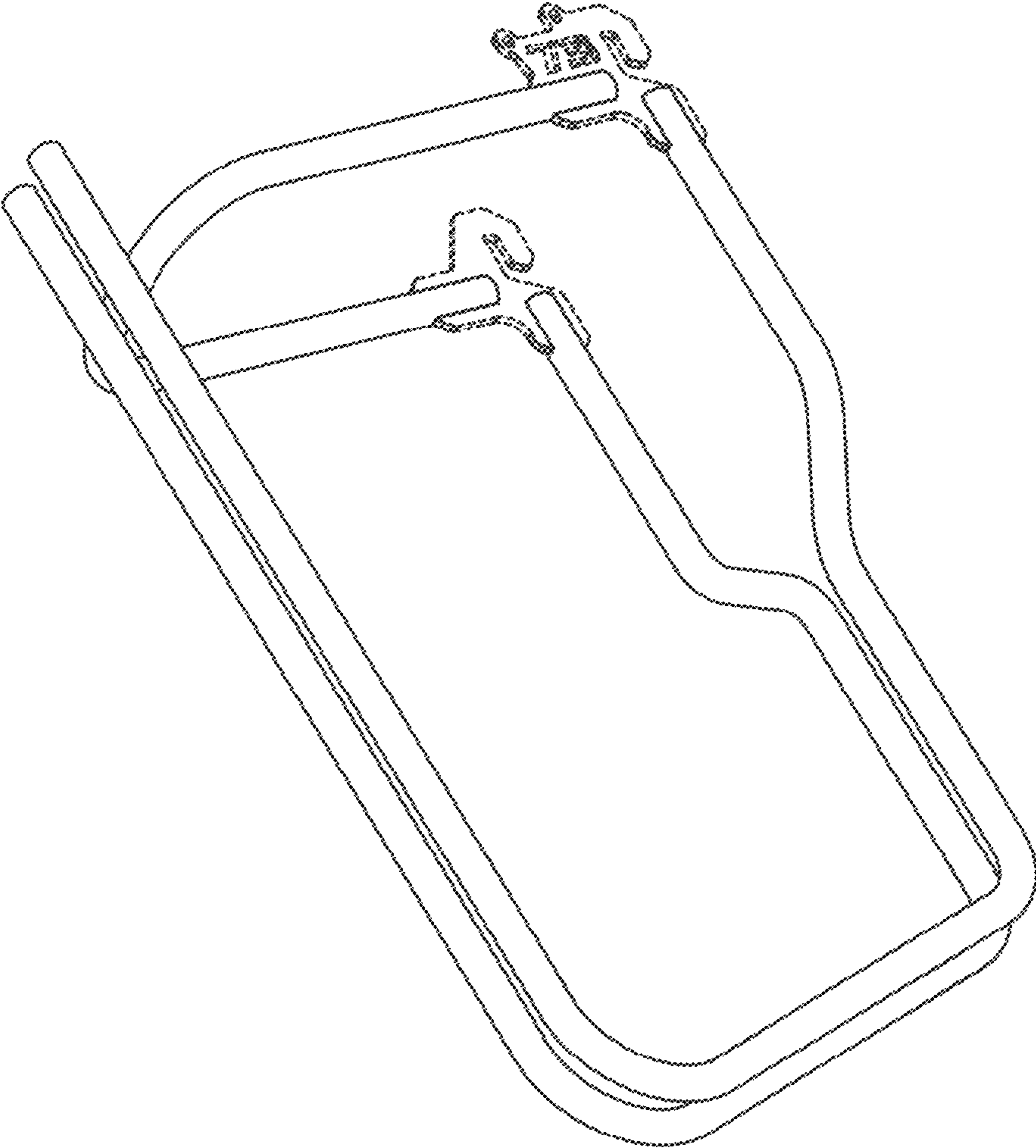

FIG. 1

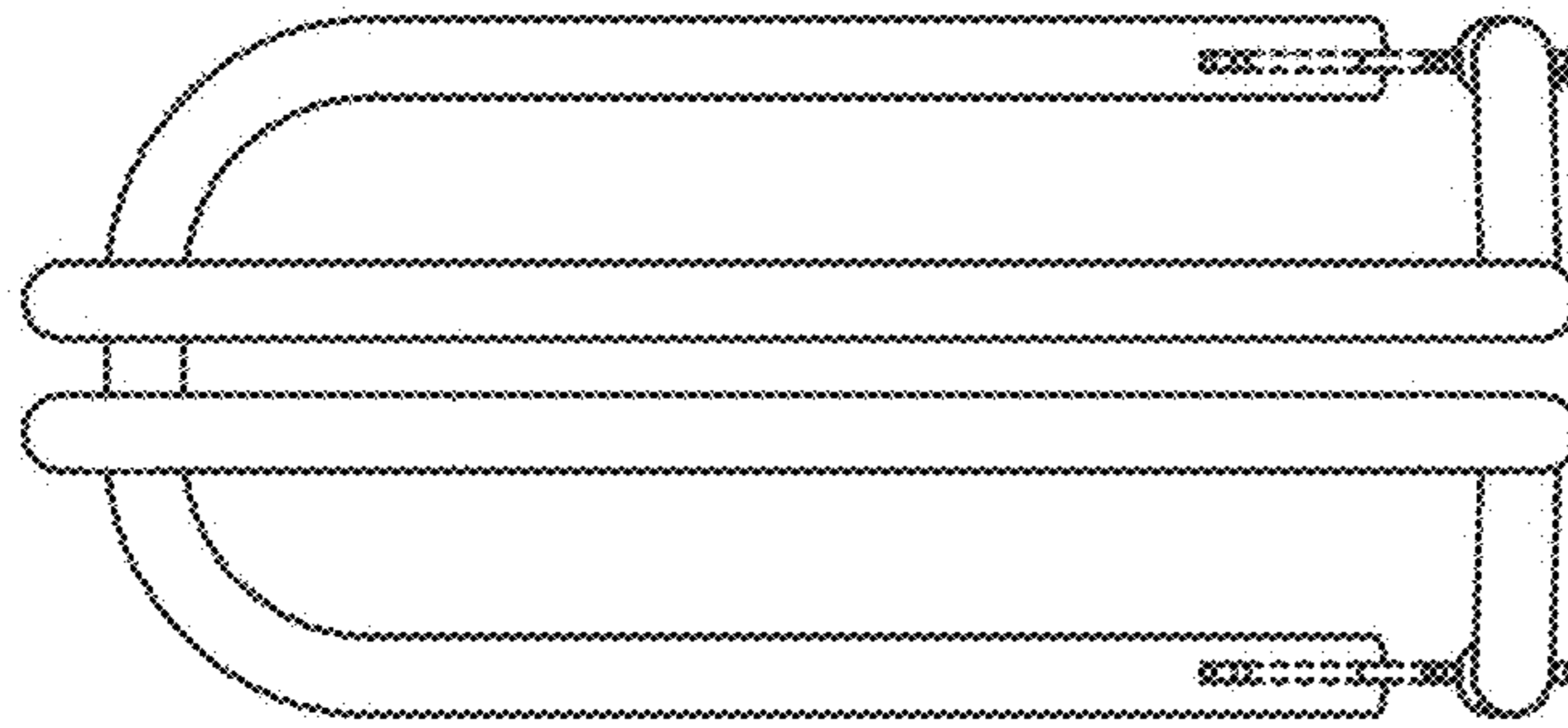

FIG. 2

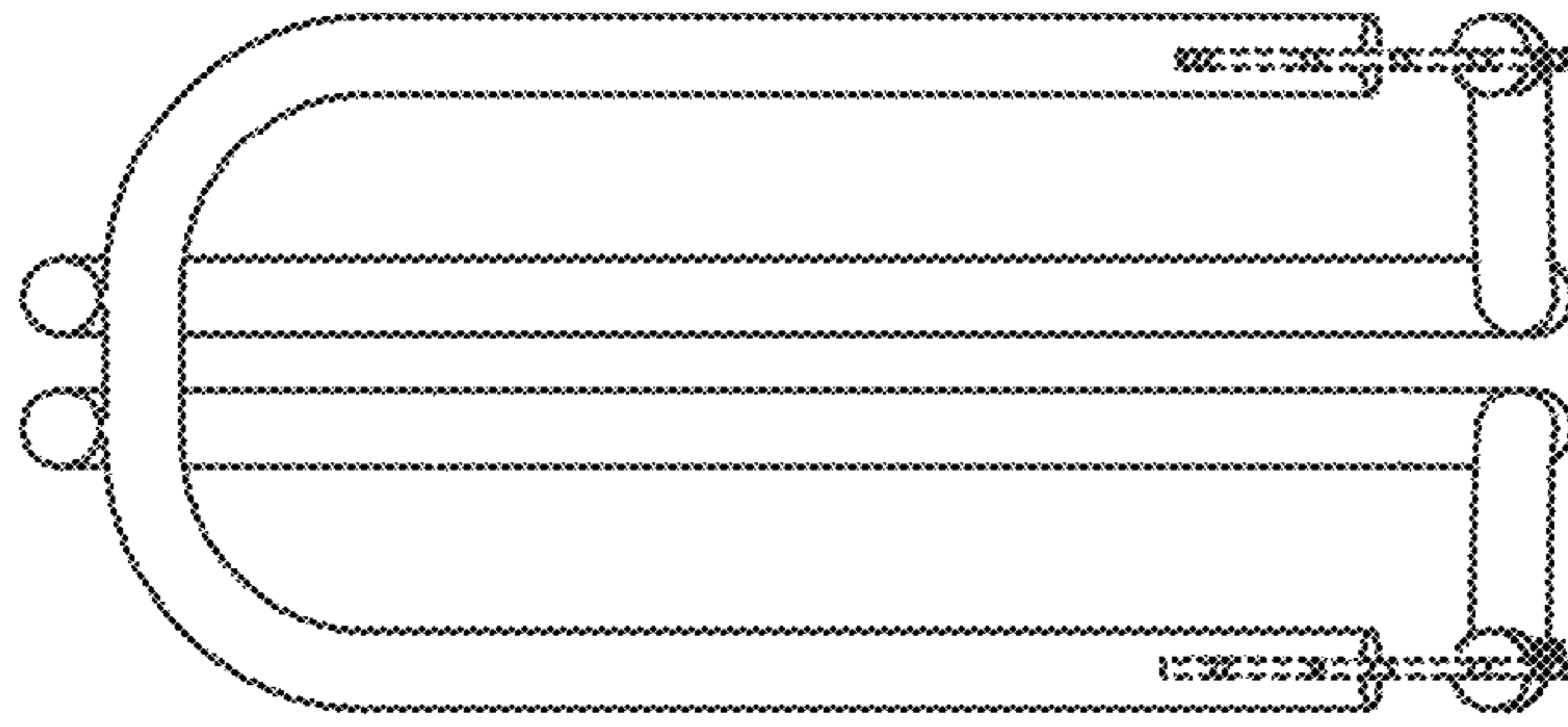

FIG. 3

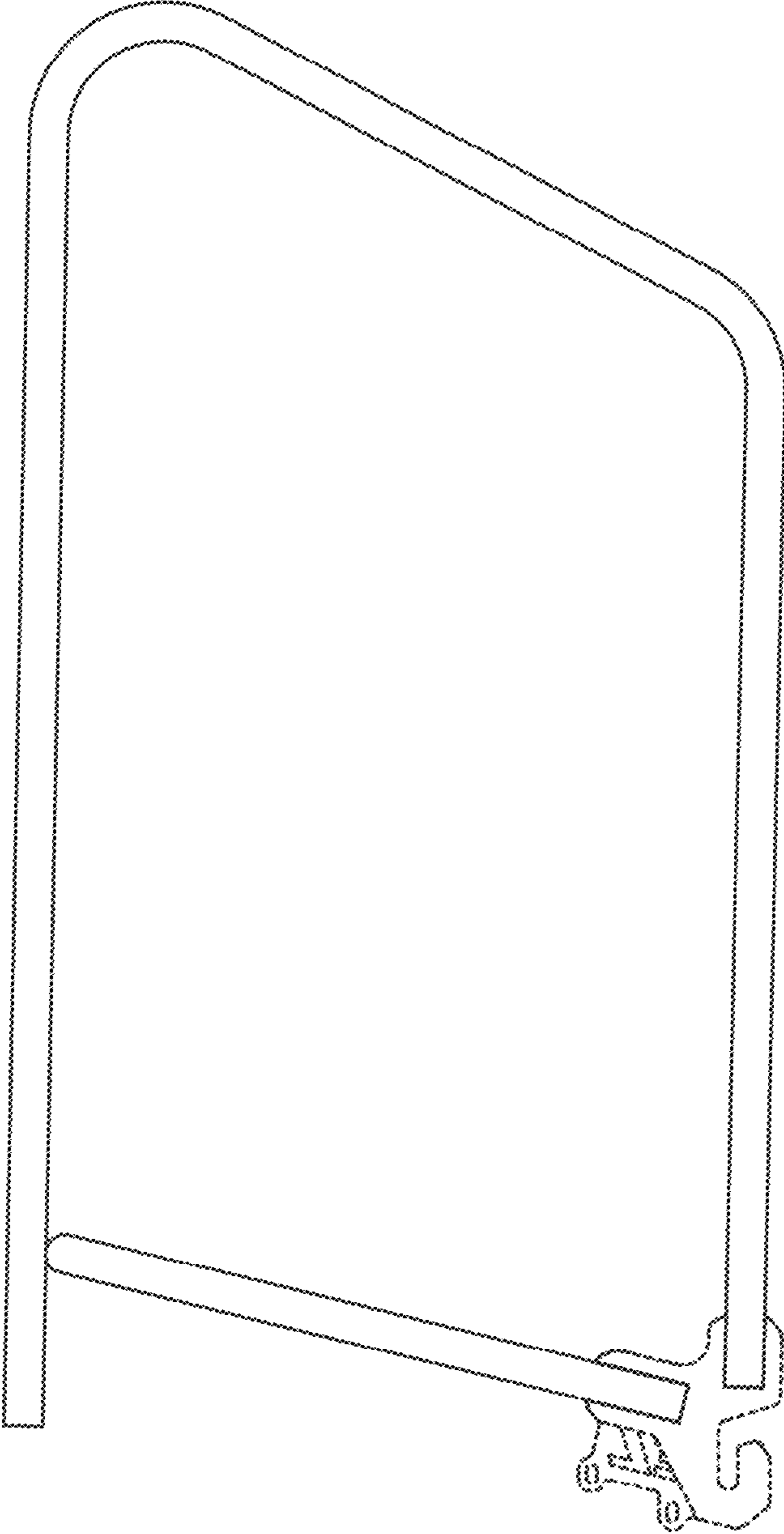

FIG. 4

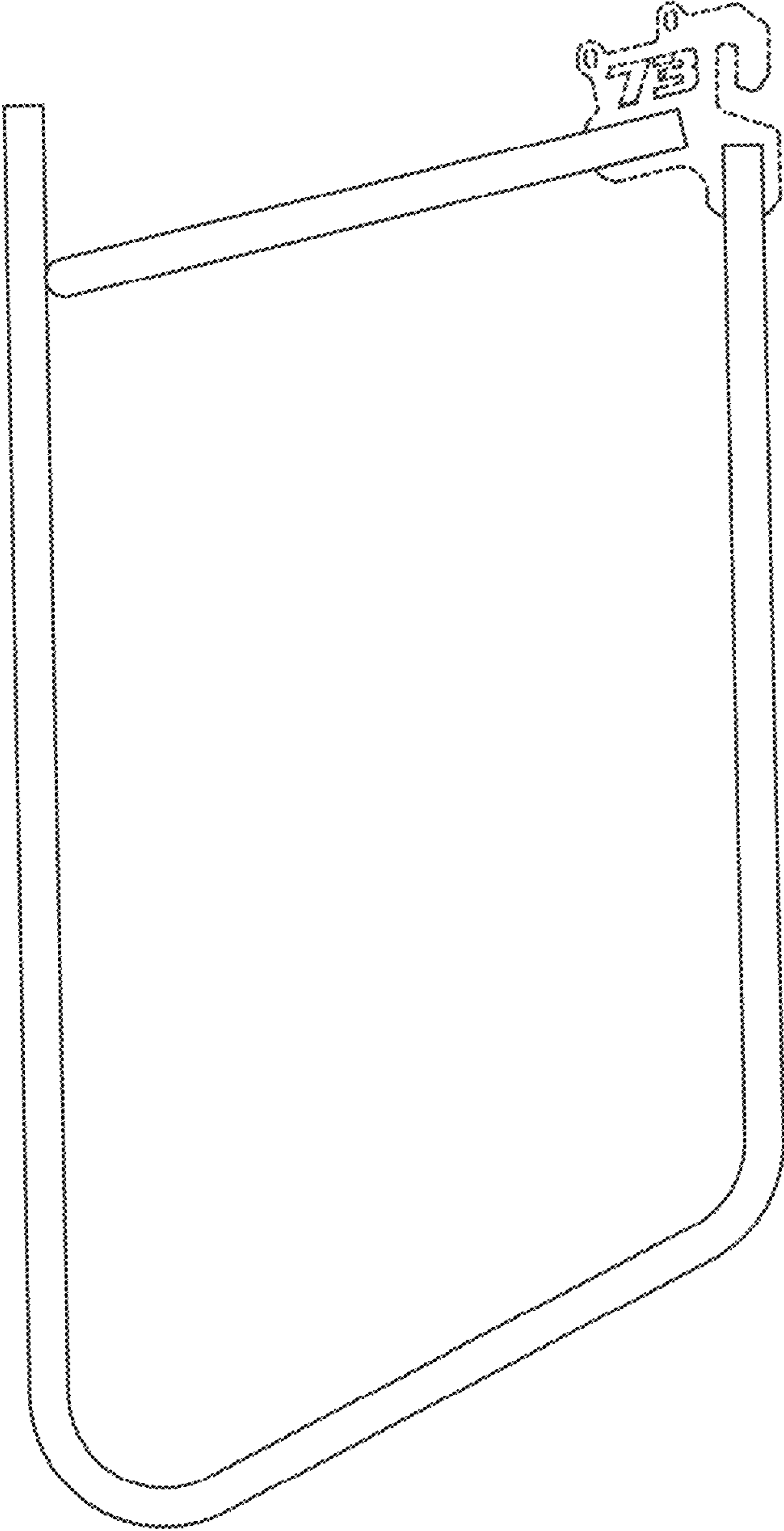

FIG. 5

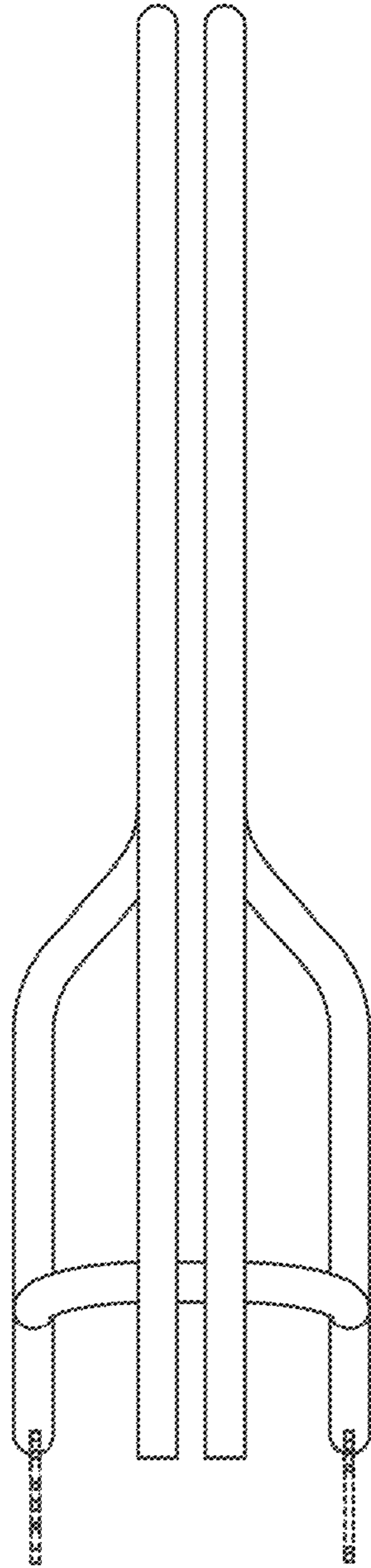

FIG. 6

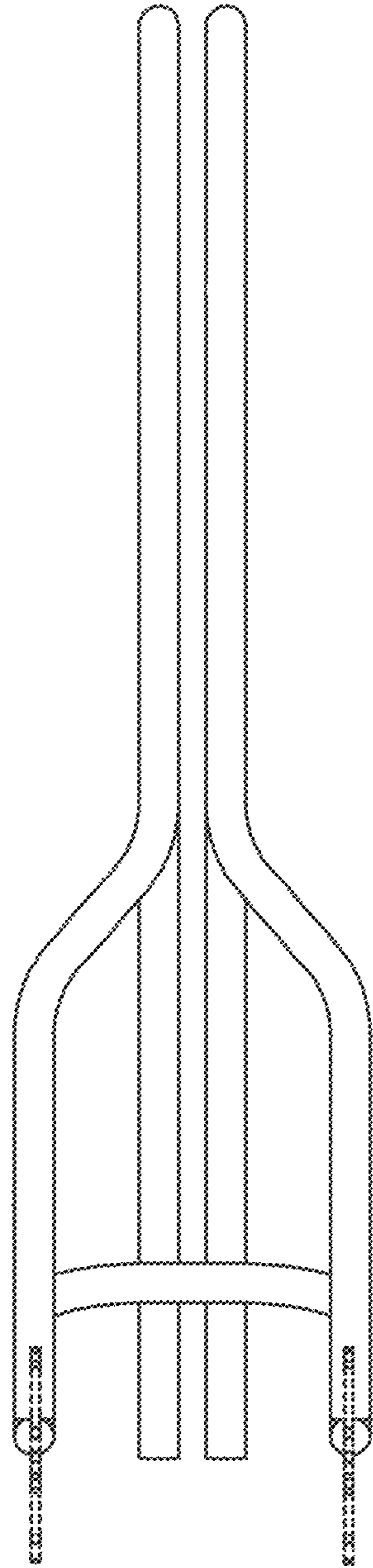

FIG. 7