



US00D906204S

(12) **United States Design Patent**
Brown

(10) **Patent No.:** **US D906,204 S**

(45) **Date of Patent:** **** Dec. 29, 2020**

(54) **SET OF AUTOMOBILE DOOR VISORS**

D563,854 S * 3/2008 Stuart D12/191
D597,912 S * 8/2009 Tsay D12/191

(71) Applicant: **Focus Auto Design Inc.**, Calgary (CA)

* cited by examiner

(72) Inventor: **Christopher Brown**, Calgary (CA)

Primary Examiner — Abraham Bahta

(**) Term: **15 Years**

(74) *Attorney, Agent, or Firm* — Thomas E. Malyszko

(21) Appl. No.: **29/676,561**

(57) **CLAIM**

The ornamental design for a set of automobile door visors, as shown and described.

(22) Filed: **Jan. 11, 2019**

DESCRIPTION

(30) **Foreign Application Priority Data**

Jul. 12, 2018 (CA) 182450

(51) **LOC (12) Cl.** **12-16**

(52) **U.S. Cl.**

USPC **D12/191**

(58) **Field of Classification Search**

USPC D12/190, 191, 163, 164, 181, 132, 418,
D12/420; 362/492; 296/97.1

CPC ... B60R 2001/1269; B60R 7/05; B60R 99/00;
B60J 3/00

See application file for complete search history.

(56) **References Cited**

U.S. PATENT DOCUMENTS

D310,652 S * 9/1990 Nagata D12/181
D404,698 S * 1/1999 Schenk D12/181
D544,821 S * 6/2007 Elwell D12/191
D554,571 S * 11/2007 Elwell D12/191
D556,657 S * 12/2007 Elwell D12/191

FIG. 1 is a front-right side perspective view of the set of automobile door visors showing my new design; FIG. 2 is a rear-right side perspective view thereof; FIG. 3 is a front-left side perspective view thereof; FIG. 4 is a rear-left side perspective view thereof; FIG. 5 is a perspective view thereof; FIG. 6 is another perspective view thereof; FIG. 7 is a top plan view thereof; FIG. 8 is a left end view thereof; FIG. 9 is a right end view thereof; FIG. 10 is a front-right side perspective view of a second embodiment of the set of automobile door visors; FIG. 11 is a rear-right side perspective view thereof; FIG. 12 is a front-left side perspective view thereof; FIG. 13 is a rear-left side perspective view thereof; FIG. 14 is a perspective view thereof; FIG. 15 is another perspective view thereof; FIG. 16 is a top plan view thereof; FIG. 17 is a left end view thereof; and, FIG. 18 is a right end view thereof.

The portions of the automobile shown in broken lines in FIGS. 5 and 14 illustrate environment which forms no part of the claimed design.

1 Claim, 8 Drawing Sheets

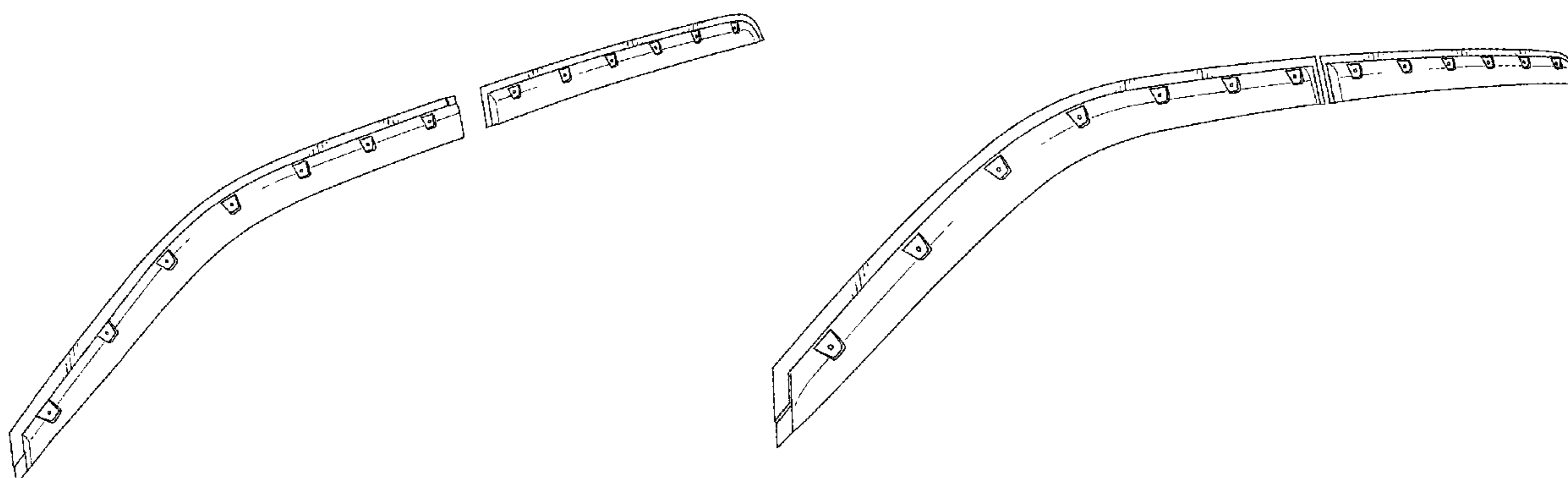

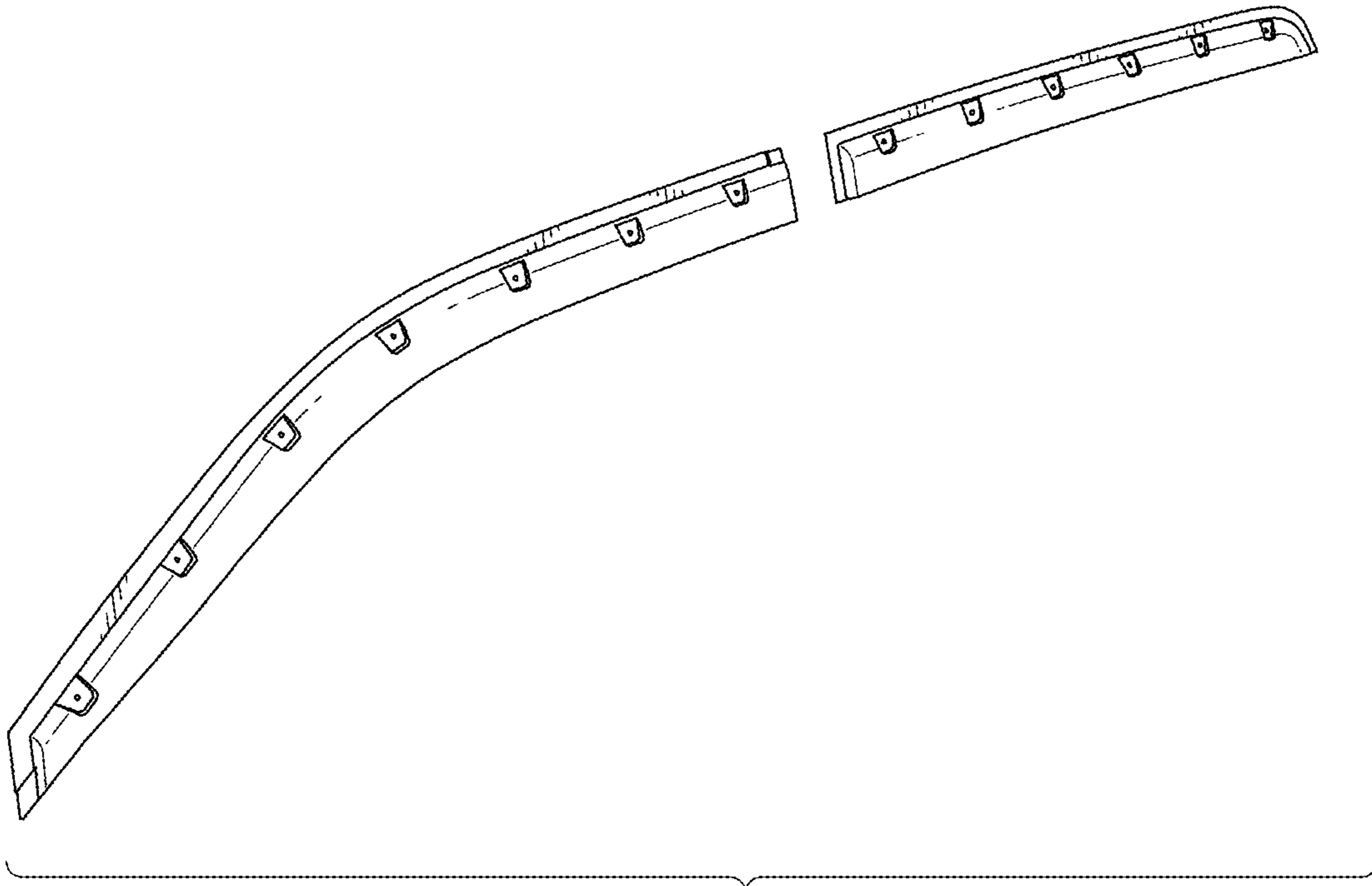

FIGURE 1

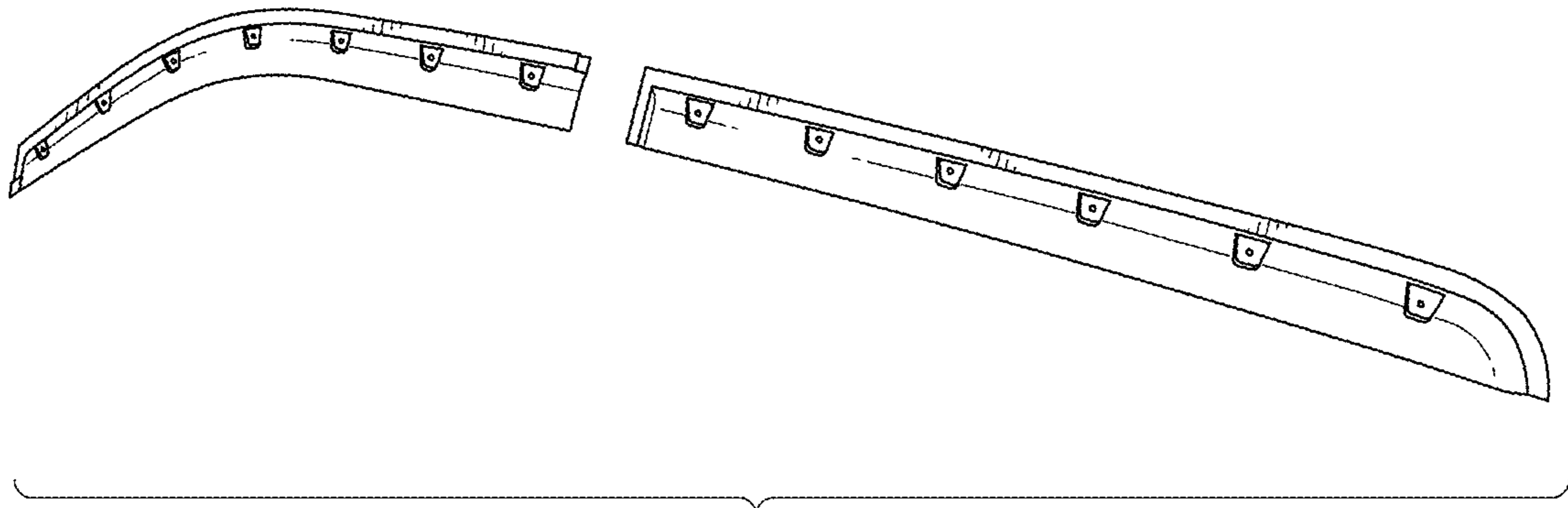

FIGURE 2

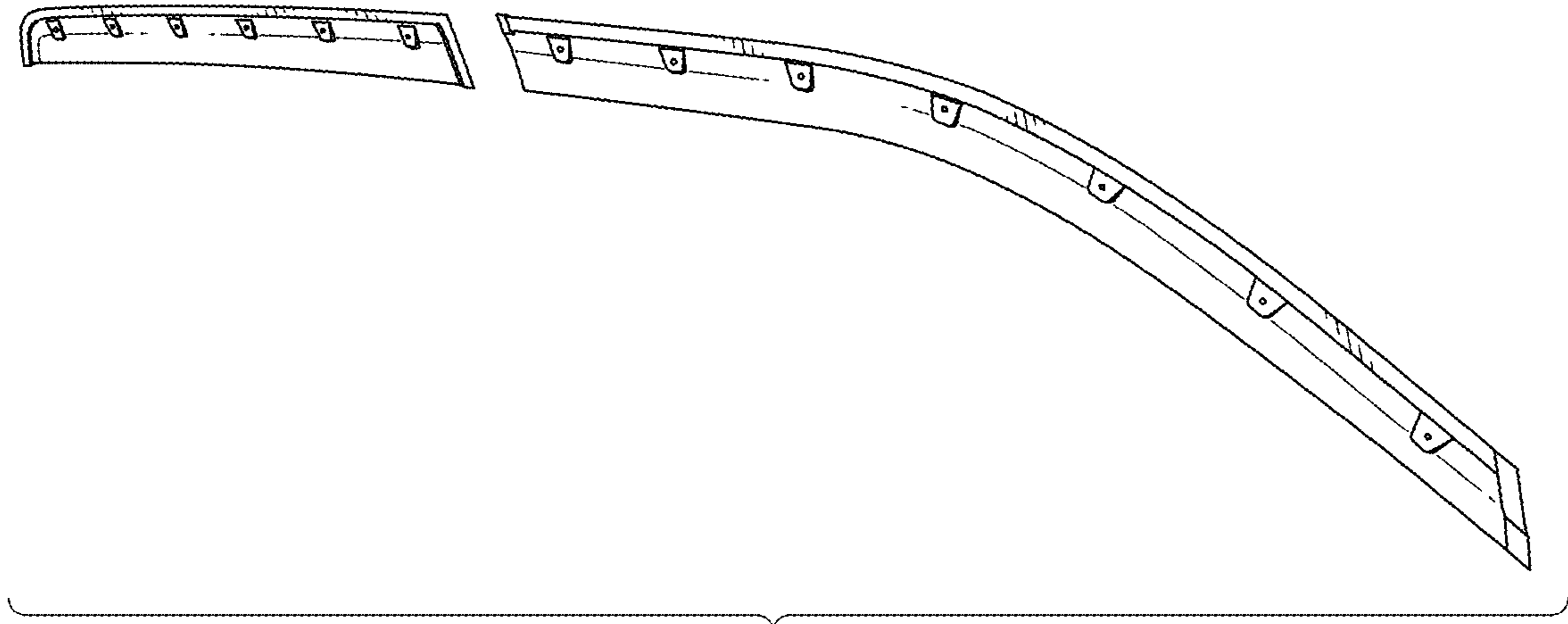

FIGURE 3

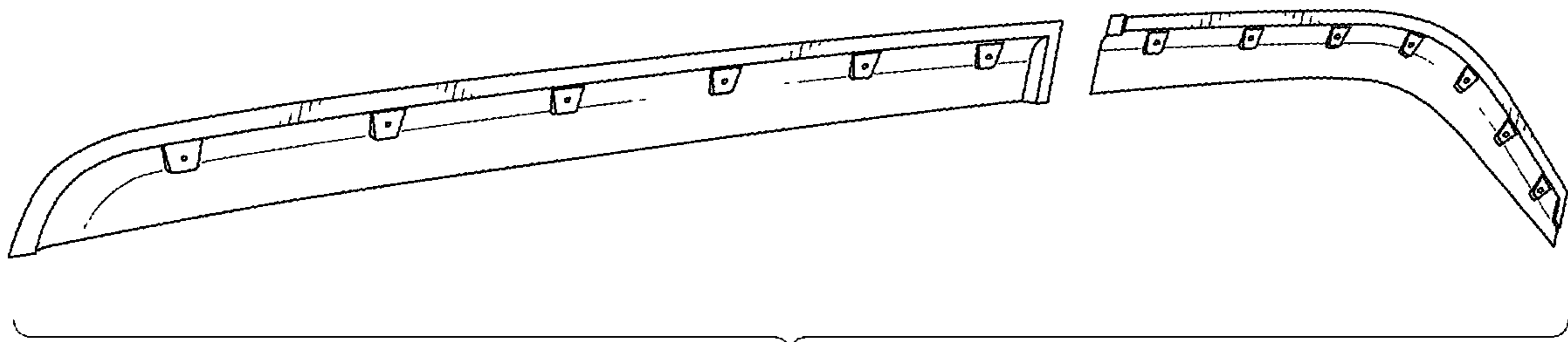

FIGURE 4

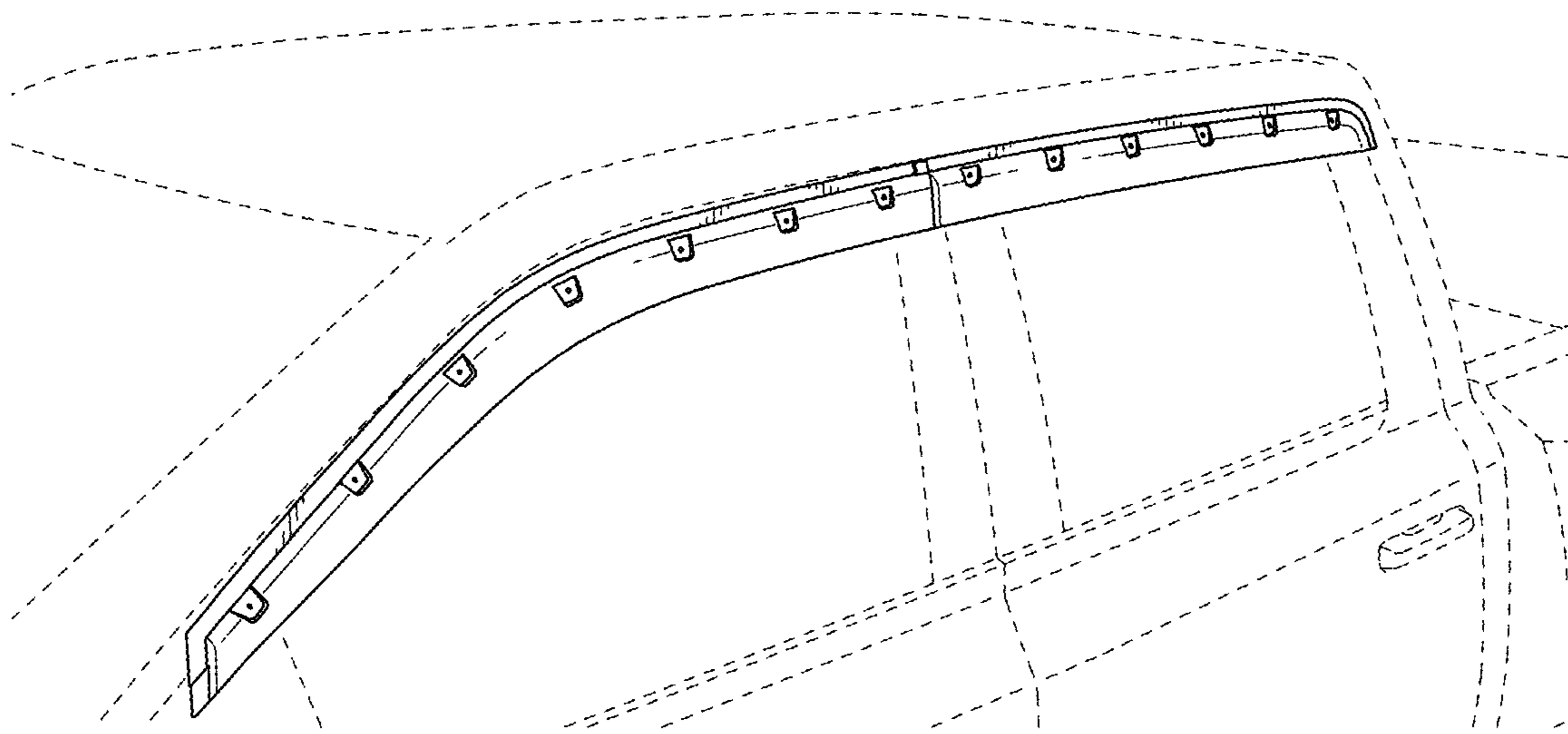

FIGURE 5

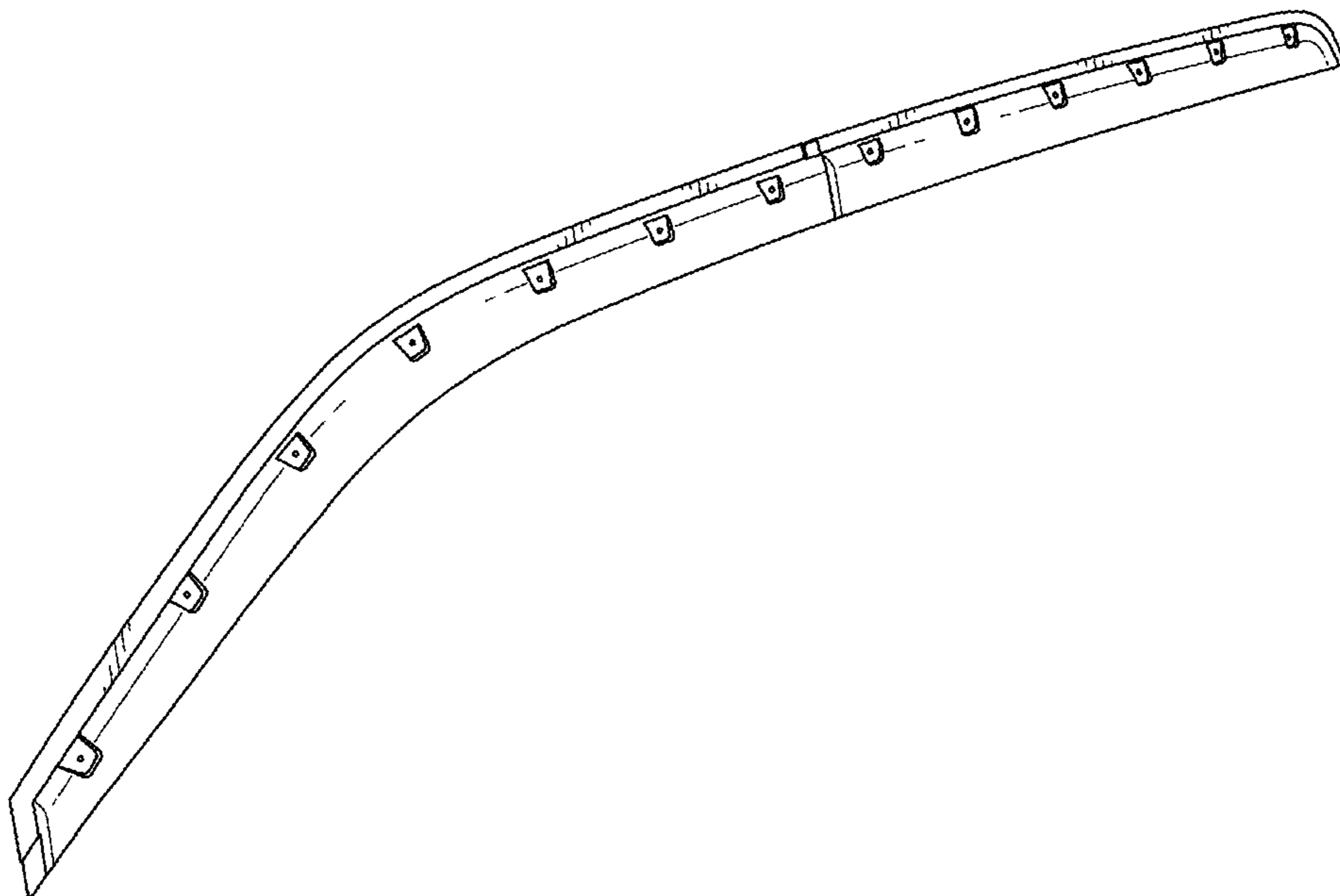

FIGURE 6

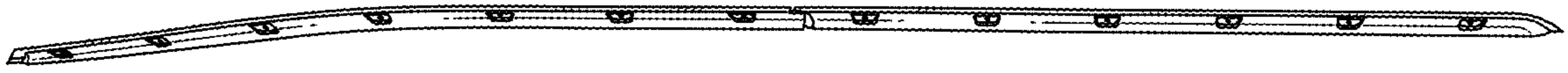

FIGURE 7

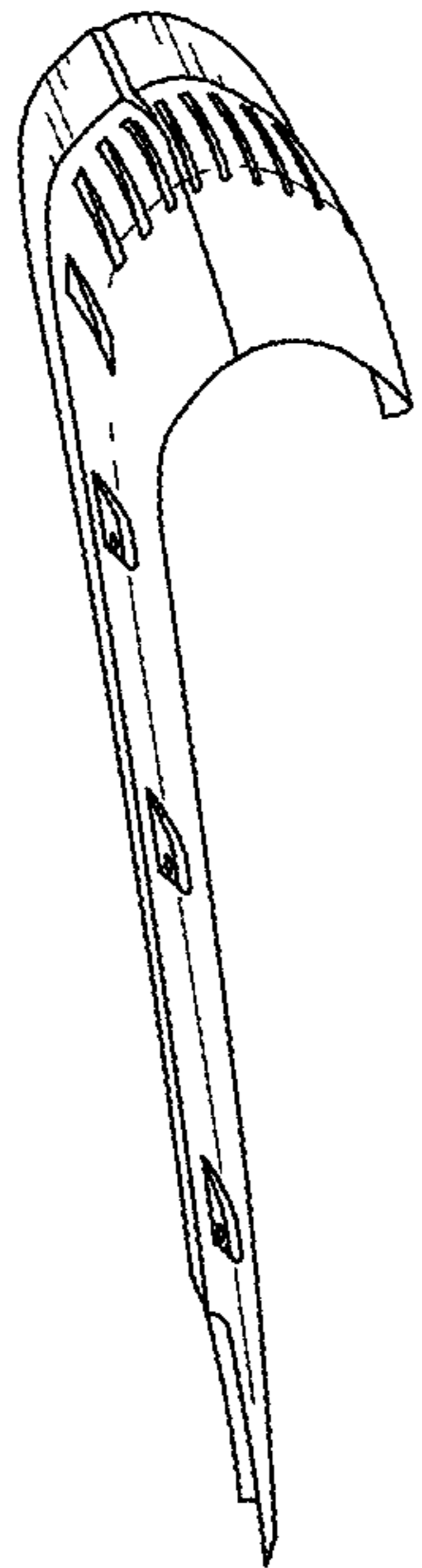

FIGURE 8

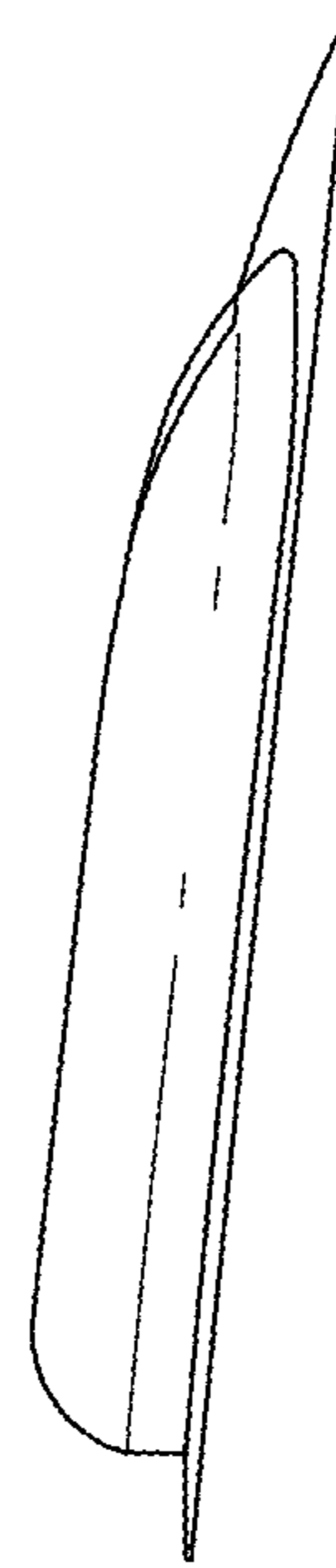

FIGURE 9

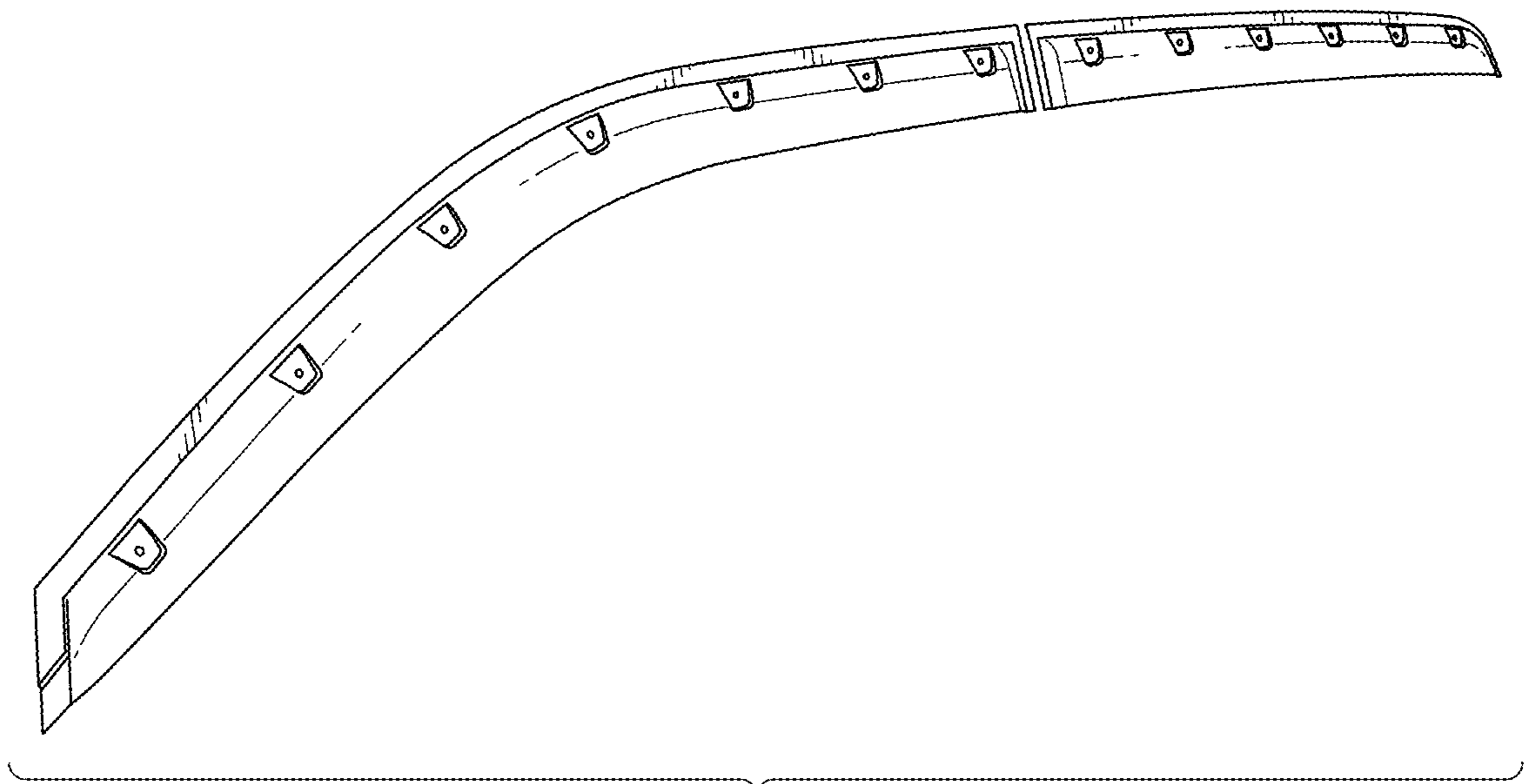

FIGURE 10

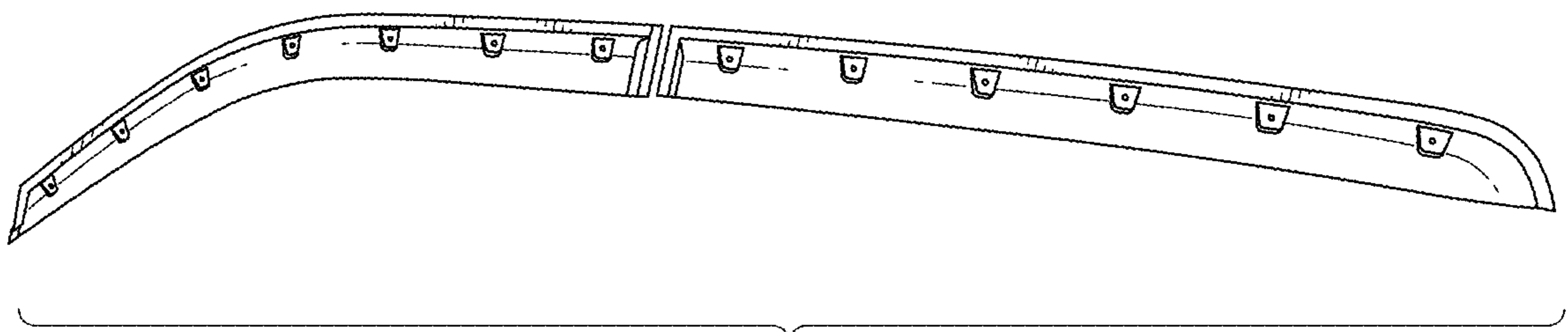

FIGURE 11

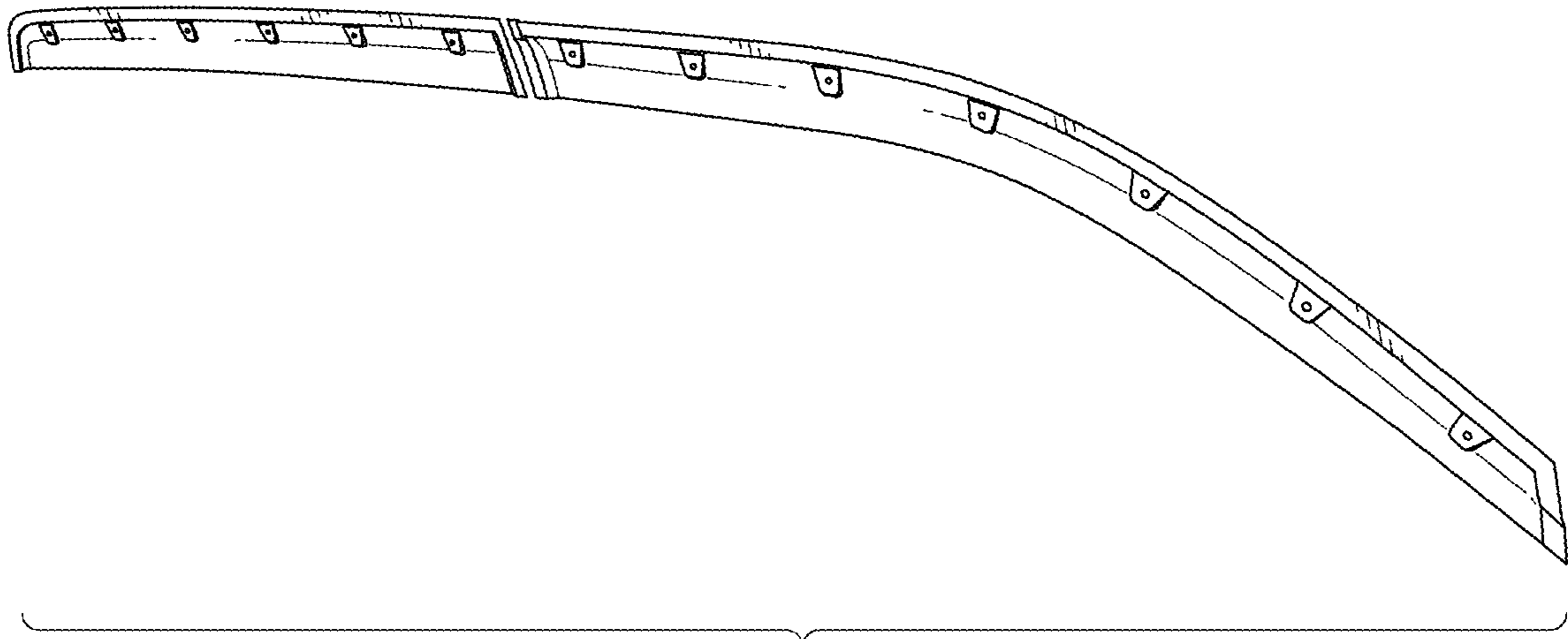

FIGURE 12

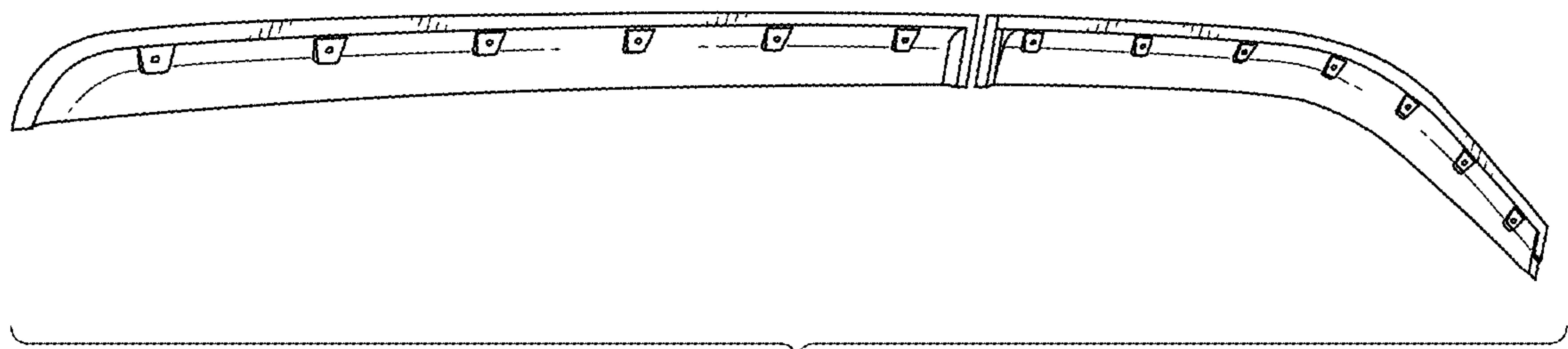

FIGURE 13

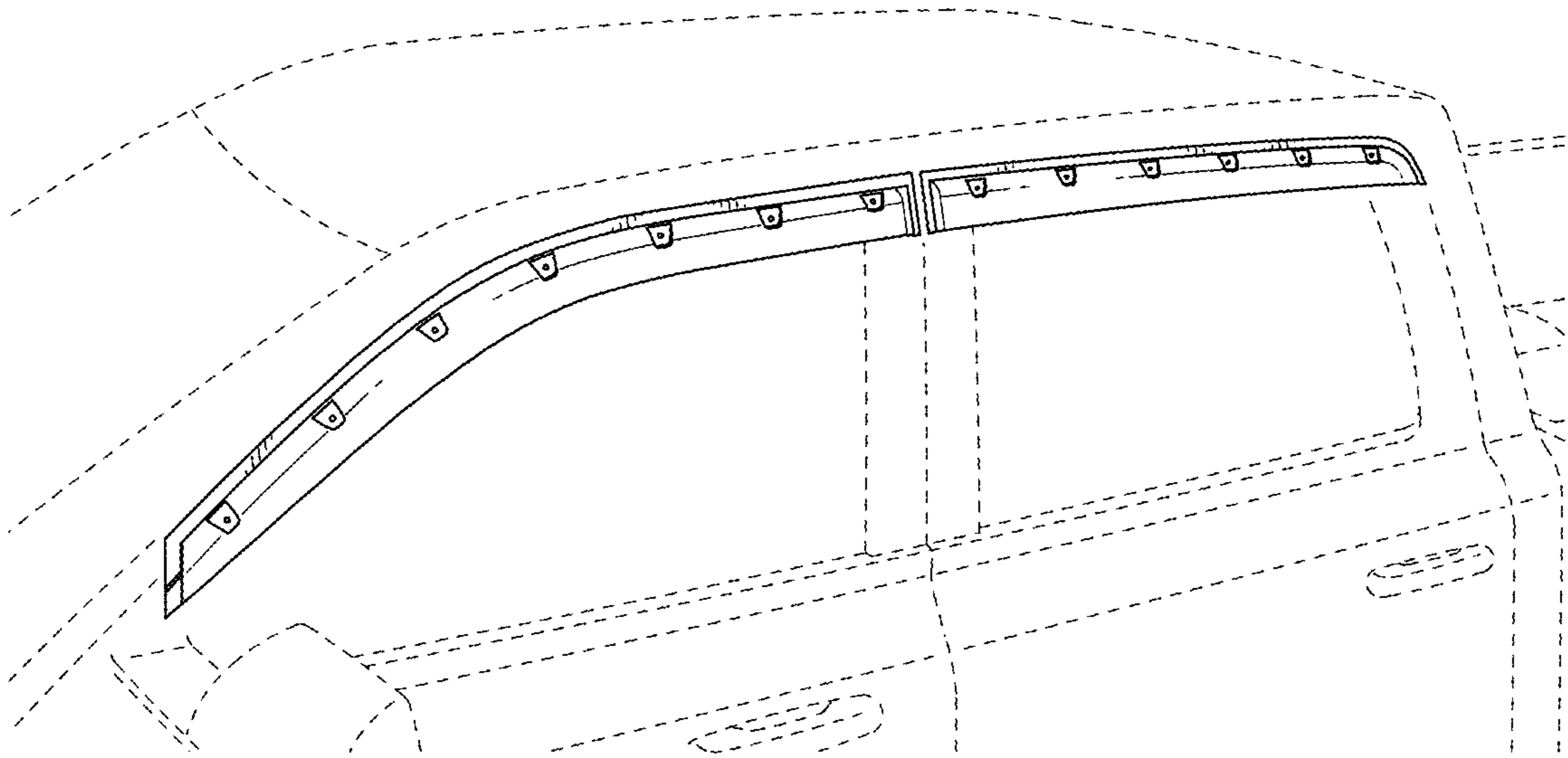

FIGURE 14

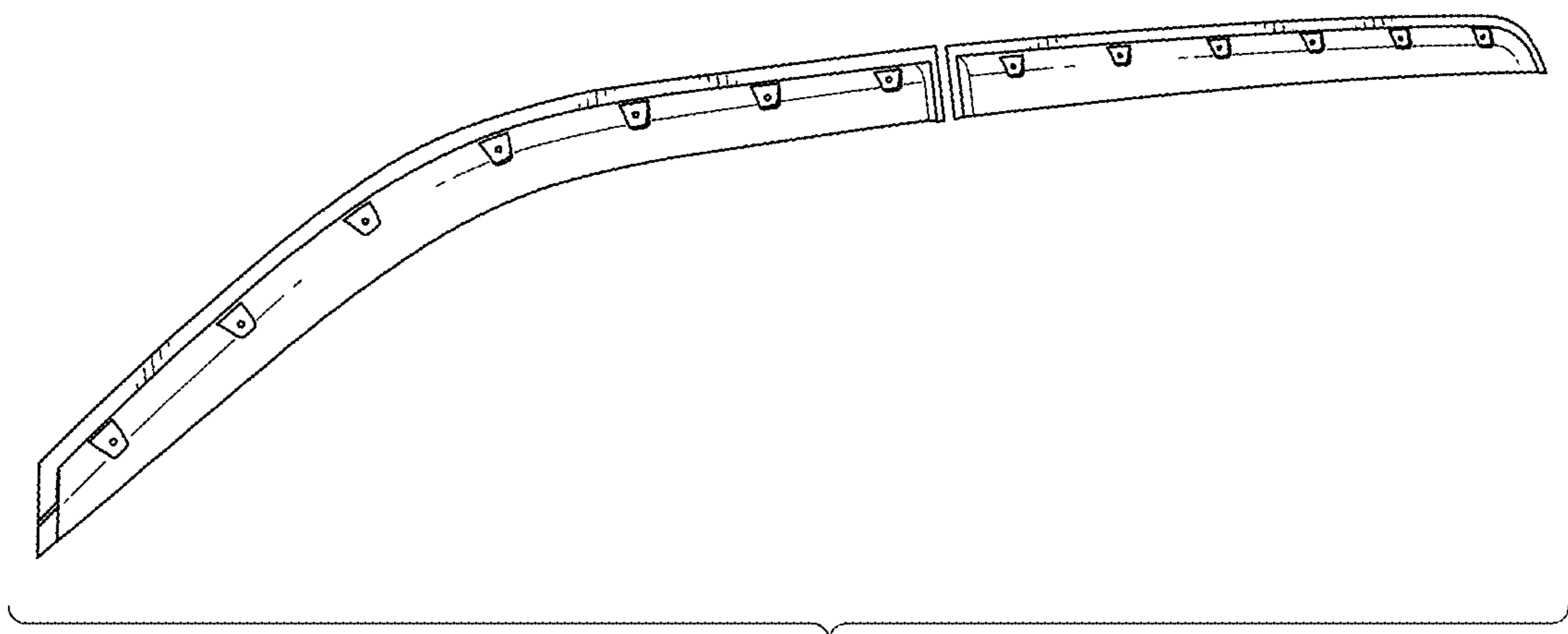

FIGURE 15

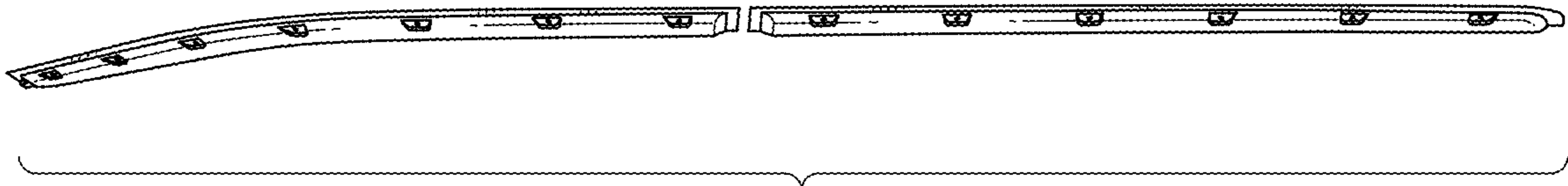

FIGURE 16

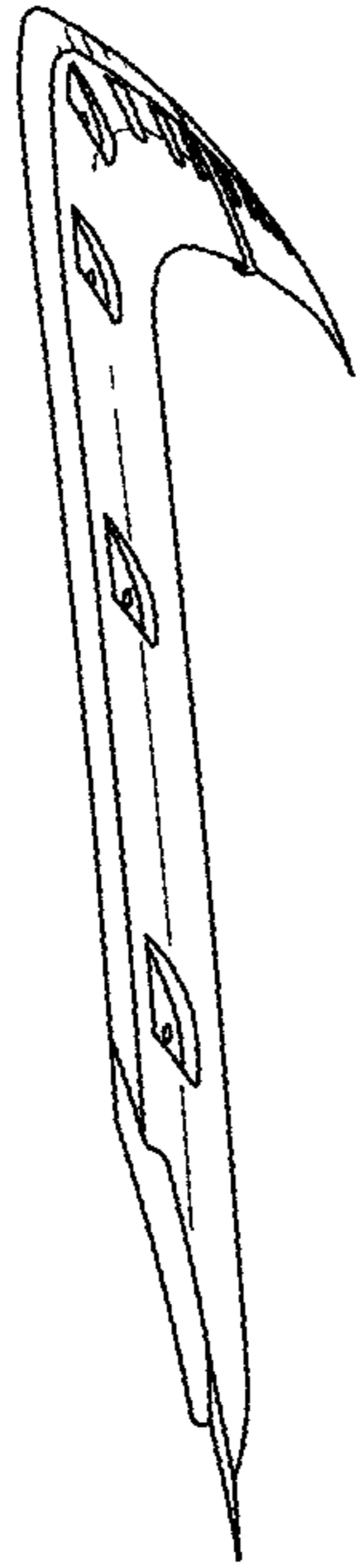

FIGURE 17

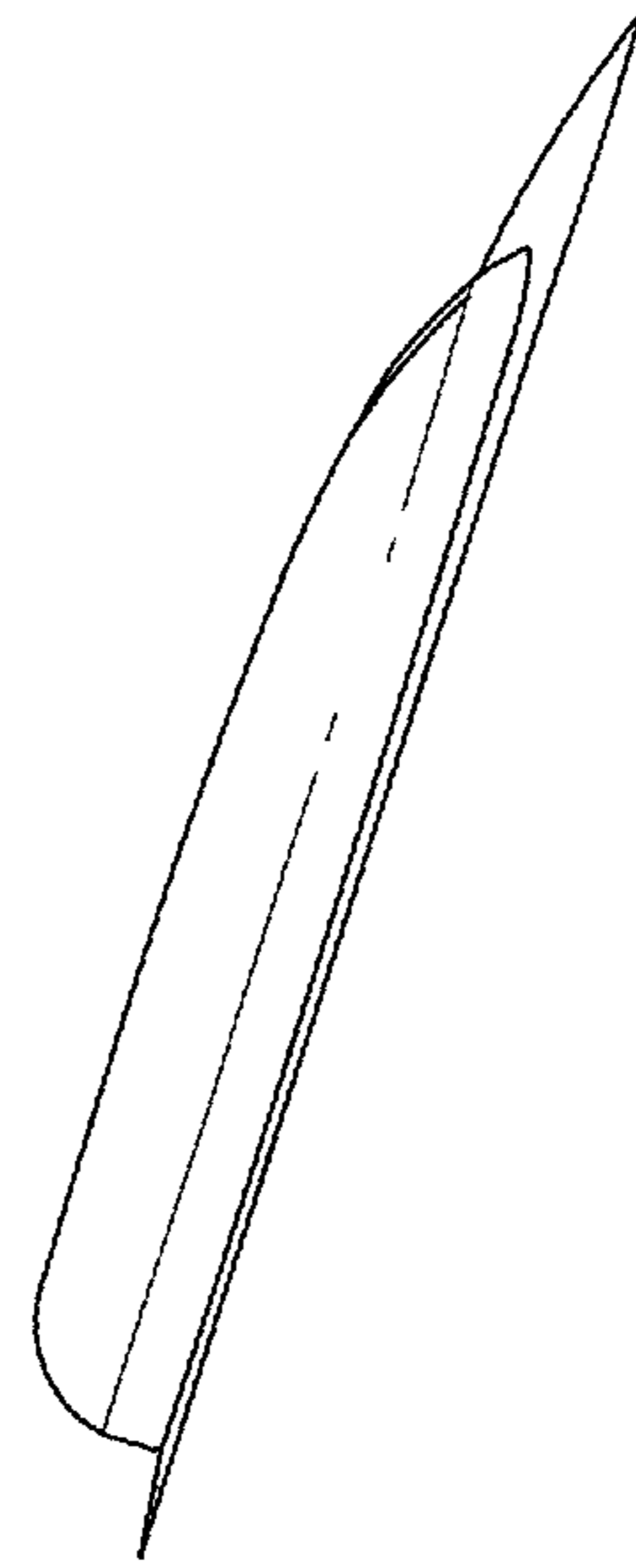

FIGURE 18