



US00D905799S

(12) **United States Design Patent** (10) **Patent No.:** **US D905,799 S**  
**Ewing et al.** (45) **Date of Patent:** **\*\* Dec. 22, 2020**

(54) **MODEL VEHICLE LOWER SUSPENSION ARM**

(71) Applicant: **TRAXXAS LP**, McKinney, TX (US)

(72) Inventors: **Adam Cole Ewing**, McKinney, TX (US); **Otto Karl Allmendinger**, Rowlett, TX (US)

(73) Assignee: **TRAXXAS LP**, McKinney, TX (US)

(\*\*) Term: **15 Years**

(21) Appl. No.: **29/696,390**

(22) Filed: **Jun. 27, 2019**

(51) **LOC (12) Cl.** ..... **21-01**

(52) **U.S. Cl.**

USPC ..... **D21/562**; D21/548; D21/561; D12/159

(58) **Field of Classification Search**

USPC ..... D21/424, 433, 434, 483, 495, 522, D21/533-562; D12/86-93, 98, 159, D12/163-172, 401; 446/431, 448, 446/454-456, 465-466, 470-471

CPC ..... B60G 2204/128; B60G 13/003; B62D 25/00; B62D 35/00; A63H 17/262; A63H 17/00; A63H 17/395; A63H 17/38; A63H

(Continued)

(56) **References Cited**

**U.S. PATENT DOCUMENTS**

D46,086 S 7/1914 Clark  
1,135,577 A 4/1915 Hague

(Continued)

**FOREIGN PATENT DOCUMENTS**

DE 2137757 A1 2/1973  
DE 3622552 A1 1/1988

(Continued)

**OTHER PUBLICATIONS**

Traxxas X-Maxx 8s F/R Left Lower Suspension Arm (1), Tin-Eye date May 26, 2017 [Online], [Site Visited Oct. 23, 2020] Available From Internet, URL: <https://www.modelsport.co.uk/traxxas-x-maxx-8s-f-r-left-lower-suspension-arm-1-/rc-car-products/396018> (Year: 2017).\*

(Continued)

*Primary Examiner* — Sandra Snapp

*Assistant Examiner* — Donald B Rose, Jr.

(74) *Attorney, Agent, or Firm* — Daryl R. Wright; Greg Carr

(57) **CLAIM**

We claim the ornamental design for a model vehicle lower suspension arm, as shown and described.

**DESCRIPTION**

FIG. 1 is an upper, left, front perspective view of a model vehicle lower suspension arm;

FIG. 2 is a front elevation view thereof;

FIG. 3 is a rear elevation view thereof;

FIG. 4 is a left side elevation view thereof;

FIG. 5 is a right side elevation view thereof;

FIG. 6 is a top plan view thereof;

FIG. 7 is a bottom plan view thereof;

FIG. 8 is a lower, right, rear perspective view thereof; and,

FIG. 9 is an upper, left, front perspective environmental use view of the model vehicle lower suspension arm.

The broken lines within the body of the claim show portions of a model vehicle lower suspension arm that form no part of the claimed design.

The broken lines in FIG. 9 depict environmental subject matter that form no part of the claimed design.

In the drawings, a first embodiment of the left model vehicle lower suspension arm is shown. It is understood that a second embodiment of the right model vehicle lower suspension arm is a mirror image thereof.

**1 Claim, 7 Drawing Sheets**

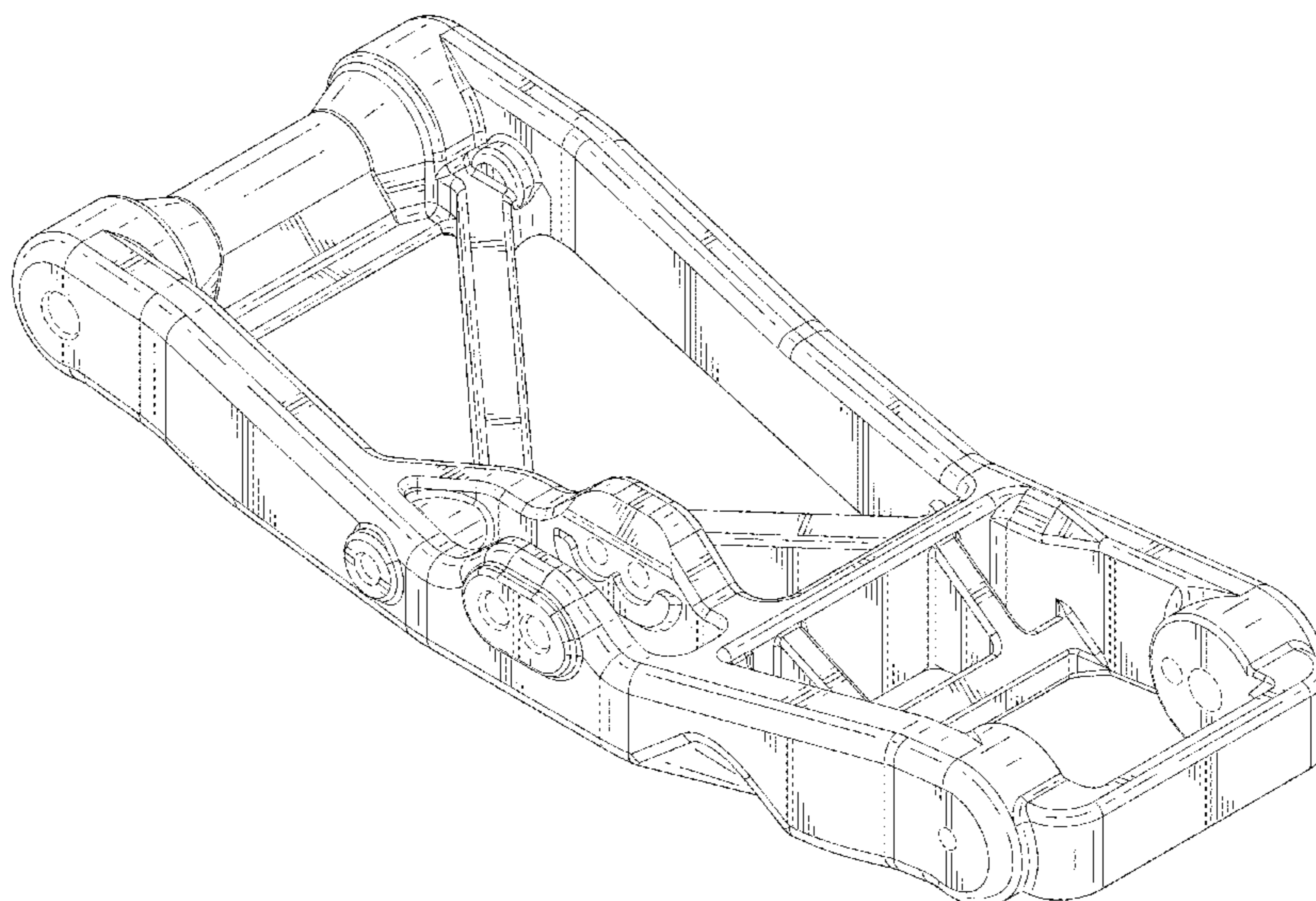

(58) **Field of Classification Search**  
 CPC ..... 17/26; A63H 17/28; A63H 33/042; A63H  
 3/16; A63H 3/50; A63H 30/00; A63H  
 7/04; A63H 17/36; A63H 17/264; B60R  
 19/02; B60R 19/023; B60R 19/18; B60R  
 19/24; B60R 19/44; B60R 19/48; B60R  
 19/56; B60R 2019/527; B60R 2019/1886  
 See application file for complete search history.

(56) **References Cited**  
 U.S. PATENT DOCUMENTS

|               |         |   |                   |         |  |
|---------------|---------|---|-------------------|---------|--|
| 1,647,438 A   | 11/1927 | De Ram                                  | 5,839,742 A       | 11/1998 | Holt                                       |
| 1,695,379 A   | 12/1928 | Keck                                    | 5,845,926 A       | 12/1998 | Davis et al.                               |
| 1,998,477 A   | 4/1935  | Wikander                                | 5,915,727 A       | 6/1999  | Bonnville                                  |
| 2,123,681 A   | 7/1938  | Willgoos                                | 5,934,696 A       | 8/1999  | Bloser et al.                              |
| 2,126,085 A   | 8/1938  | Balz                                    | 5,938,219 A       | 8/1999  | Hayami et al.                              |
| 2,131,661 A   | 9/1938  | Heyermans et al.                        | 5,992,863 A       | 11/1999 | Forbes-Robinson et al.                     |
| 2,153,083 A   | 4/1939  | Griswold                                | 6,076,840 A       | 6/2000  | Kincaid et al.                             |
| 2,186,065 A   | 1/1940  | Fischer                                 | 6,142,268 A       | 11/2000 | Kuo-An                                     |
| 2,219,361 A   | 10/1940 | Haberstump                              | D435,236 S        | 12/2000 | Hanlon et al.                              |
| 2,232,397 A   | 2/1941  | Leighton                                | 6,170,838 B1      | 1/2001  | Laurent et al.                             |
| 2,264,174 A   | 11/1941 | Crump et al.                            | 6,206,392 B1      | 3/2001  | Siecinski et al.                           |
| 2,580,559 A   | 1/1952  | Kolbe                                   | 6,478,655 B2      | 11/2002 | Wu   |
| 2,624,592 A   | 1/1953  | Macpherson                              | 6,550,796 B2      | 4/2003  | Behr                                       |
| 2,643,110 A   | 6/1953  | Gregoire                                | D475,001 S        | 5/2003  | Roll                                       |
| 2,678,803 A   | 5/1954  | Wilkerson                               | 6,595,714 B2      | 7/2003  | Moore                                      |
| 2,776,147 A   | 1/1957  | Bamford                                 | 6,641,457 B1      | 11/2003 | Lai  |
| 2,852,269 A   | 9/1958  | Gaines                                  | 6,655,118 B1      | 12/2003 | Thompson et al.                            |
| 2,913,253 A   | 11/1959 | Taber                                   | 6,668,779 B2      | 12/2003 | Hendriksma et al.                          |
| 2,931,663 A   | 4/1960  | Ferand                                  | 6,685,203 B1      | 2/2004  | Bodin et al.                               |
| 2,992,014 A   | 7/1961  | Muller                                  | 6,698,963 B1      | 3/2004  | Parker et al.                              |
| 3,034,810 A   | 5/1962  | Primean                                 | 6,702,307 B2      | 3/2004  | Becker et al.                              |
| 3,059,950 A   | 10/1962 | Hedges                                  | 6,719,313 B2      | 4/2004  | Zadok                                      |
| 3,177,004 A   | 4/1965  | Schmidt                                 | 6,752,411 B2      | 6/2004  | Few  |
| 3,231,040 A   | 1/1966  | Blanchette                              | 6,761,372 B2      | 7/2004  | Bryant                                     |
| 3,410,575 A   | 11/1968 | Tumbull et al.                          | 6,767,021 B2      | 7/2004  | Schnurpel                                  |
| 3,448,991 A   | 6/1969  | Leggett                                 | 6,881,122 B2      | 4/2005  | Bloch et al.                               |
| 3,545,125 A   | 12/1970 | Okuma                                   | 6,929,273 B2      | 8/2005  | Dobson et al.                              |
| 3,583,052 A   | 6/1971  | Herbenar et al.                         | 6,932,366 B2      | 8/2005  | Jones et al.                               |
| 3,591,198 A   | 7/1971  | Brando                                  | 6,945,843 B1      | 9/2005  | Motosko                                    |
| 3,632,127 A   | 1/1972  | Grosseau                                | 6,968,931 B2      | 11/2005 | Huisman                                    |
| 3,671,694 A   | 6/1972  | Masuda                                  | 7,152,866 B2      | 12/2006 | Chalin et al.                              |
| 3,721,455 A   | 3/1973  | Blanton                                 | 7,185,902 B1      | 3/2007  | Lloyd                                      |
| 3,727,938 A   | 4/1973  | Goodbary et al.                         | 7,367,573 B2      | 5/2008  | Kudo et al.                                |
| 3,738,631 A   | 6/1973  | Haley                                   | 7,883,099 B2      | 2/2011  | Byers et al.                               |
| 3,787,073 A   | 1/1974  | Lievore                                 | 7,887,074 B2      | 2/2011  | Byers et al.                               |
| 3,938,822 A   | 2/1976  | Guerrero                                | 8,549,752 B1      | 10/2013 | Byers                                      |
| D262,959 S    | 2/1982  | Cowan                                   | D785,513 S *      | 5/2017  | Park ..... D12/159                         |
| 4,470,611 A   | 9/1984  | Duphily et al.                          | D788,653 S *      | 6/2017  | Smith ..... D12/159                        |
| D277,952 S    | 3/1985  | Nakano et al.                           | D827,054 S *      | 8/2018  | Ewing ..... D21/561                        |
| 4,534,575 A   | 8/1985  | Grove et al.                            | D828,460 S        | 9/2018  | Wood                                       |
| 4,546,997 A   | 10/1985 | Smyers                                  | 10,266,025 B2     | 4/2019  | Lorenz et al.                              |
| D281,772 S    | 12/1985 | Heideman et al.                         | D852,095 S        | 6/2019  | Walter                                     |
| 4,706,989 A   | 11/1987 | Iijima et al.                           | D856,432 S        | 8/2019  | Ewing et al.                               |
| 4,786,075 A   | 11/1988 | Takahashi                               | D865,079 S *      | 10/2019 | Ewing ..... A63H 17/262<br>D21/561         |
| 4,807,901 A   | 2/1989  | Kondo                                   | 10,435,075 B2     | 10/2019 | Lorenz et al.                              |
| 4,881,752 A   | 11/1989 | Tanaka                                  | D867,475 S *      | 11/2019 | Ewing ..... A63H 17/262<br>D21/561         |
| 4,955,634 A   | 9/1990  | Smith                                   | D875,186 S *      | 2/2020  | Ewing ..... B60G 7/001<br>D21/561          |
| 5,004,257 A   | 4/1991  | MacIsaac                                | 2002/0041076 A1   | 4/2002  | Becker et al.                              |
| 5,080,389 A   | 1/1992  | Kawano et al.                           | 2002/0077025 A1 * | 6/2002  | Wu ..... A63H 17/262<br>446/465            |
| 5,108,126 A   | 4/1992  | Banse                                   | 2002/0125676 A1   | 9/2002  | Bryant                                     |
| D335,851 S    | 5/1993  | Lofy                                    | 2003/0107198 A1   | 6/2003  | VanDenberg                                 |
| D337,555 S    | 7/1993  | McNab et al.                            | 2003/0122336 A1   | 7/2003  | Zadok                                      |
| 5,284,353 A   | 2/1994  | Shinji et al.                           | 2003/0209217 A1   | 11/2003 | Hendriksma et al.                          |
| 5,288,101 A   | 2/1994  | Minnett                                 | 2003/0227151 A1   | 12/2003 | Schreiber et al.                           |
| 5,332,255 A   | 7/1994  | Velazquez                               | 2004/0004335 A1   | 1/2004  | Rudder et al.                              |
| 5,516,130 A * | 5/1996  | Mitchell ..... B60G 3/20<br>280/124.134 | 2004/0045518 A1   | 3/2004  | Abe  |
| 5,522,281 A   | 6/1996  | Herman                                  | 2004/0261739 A1   | 12/2004 | Shimizuya                                  |
| 5,603,583 A   | 2/1997  | Jackson                                 | 2005/0040619 A1   | 2/2005  | Melcher                                    |
| D385,835 S *  | 11/1997 | Webster ..... D12/159                   | 2005/0200096 A1 * | 9/2005  | Izquierdo Nuez ..... B60G 7/001<br>280/287 |
| 5,682,849 A   | 11/1997 | Regueiro                                | 2005/0220535 A1   | 10/2005 | Griffin                                    |
| 5,692,853 A   | 12/1997 | Litz et al.                             | 2006/0006622 A1   | 1/2006  | Gesmer et al.                              |
| 5,774,984 A   | 7/1998  | Kotani                                  | 2006/0246819 A1   | 11/2006 | Byers et al.                               |
| 5,816,357 A   | 10/1998 | Camlin                                  | 2014/0361507 A1 * | 12/2014 | Park ..... B60G 7/001<br>280/124.134       |
|               |         |   | 2016/0318362 A1   | 11/2016 | Watanabe et al.                            |
|               |         |   | 2017/0050483 A1   | 2/2017  | Gordon et al.                              |
|               |         |   | 2017/0050485 A1   | 2/2017  | Eleazar                                    |
|               |         |   | 2017/0274932 A1   | 9/2017  | Thomas J Bymes, Jr.                        |
|               |         |   | 2018/0065465 A1   | 3/2018  | Ward et al.                                |
|               |         |   | 2018/0111433 A1 * | 4/2018  | Compigne ..... B60G 7/005                  |
|               |         |   | 2018/0326843 A1   | 11/2018 | Danielson et al.                           |
|               |         |   | 2018/0370310 A1   | 12/2018 | Becker et al.                              |
|               |         |   | 2019/0070919 A1   | 3/2019  | Andou et al.                               |
|               |         |   | 2019/0143871 A1   | 5/2019  | Weber et al.                               |

(56)

**References Cited**

U.S. PATENT DOCUMENTS

|              |     |         |                |            |
|--------------|-----|---------|----------------|------------|
| 2019/0145465 | A1  | 5/2019  | Olason         |            |
| 2019/0217894 | A1  | 7/2019  | Upah et al.    |            |
| 2019/0225042 | A1  | 7/2019  | Upah et al.    |            |
| 2019/0241035 | A1  | 8/2019  | Wolf-Monheim   |            |
| 2019/0283516 | A1  | 9/2019  | Gordon et al.  |            |
| 2019/0285131 | A1  | 9/2019  | Garrett        |            |
| 2019/0315174 | A1* | 10/2019 | Kwon .....     | B29C 45/17 |
| 2019/0367117 | A1  | 12/2019 | Fischer et al. |            |

FOREIGN PATENT DOCUMENTS

|    |              |    |        |
|----|--------------|----|--------|
| DE | 202018103151 | U1 | 6/2018 |
| EP | 0070025      | A2 | 1/1983 |
| EP | 3271195      | B1 | 5/2019 |
| WO | 2010066226   | A1 | 6/2010 |

OTHER PUBLICATIONS

Traxxas 7831G Suspension arm lower left F orR Green X-Maxx series, Earliest available date Oct. 15, 2020 [Online], [Site Visited Oct. 23, 2020] Available From Internet, URL in PDF (Year: 2020).\*

Associated Electrics, “Monster GT” model truck; Associated Electrics, Inc., Costa Mesa, California, photograph.

Associated Electrics, “RC10GT” model vehicle; Associated Electrics, Inc., Costa Mesa, California, photograph.

Bradley, John; “The Racing Motorcycle”; 1996, pp. 246-273, 322-325; Broadland Leisure Publications, England.

Ellsworth, Tony; “Suspension Design Enhancements—The Ellsworth Dare”; Dreamride Mountain Bike Tours and Film Services, Moab, Utah, 2001.

Horizon Hobby, “Losi XXX buggy”; Horizon Hobby, Inc., Champaign, Illinois; 1 sketch of suspension geometry.

HPI Racing, “Savage 21” model truck; Hobby Products International, Foothill Ranch, California; 1 sketch of suspension geometry.

HyperPRO\_USA; “What is Progressive Suspension?” HyperPRO\_USA.com.

Kyosho Inferno MP7.5 model car; Kyosho America, Lake Forest, California; 2 sketches of suspension geometry.

Milliken, William F. and Milliken, Douglas L.; “Race Car Vehicle Dynamics” 1995, pp. 580-583, 595-597, 628-631; SAE Publications Group, Pennsylvania USA.

Phillpotts, Peter; “Rising Rate Suspension”; Off Road Design, 2001.

Race Tech, “Profile—Chalmers Formula SAE Car” Race Tech magazine, Oct./Nov. 2003, p. 74; Racecar Graphic Ltd, London, England.

Racecar Engineering, Jun. 2003—vol. 13 No. 06, pp. 15, 106; Country & Leisure Media Ltd./IPC Media Ltd., Croydon, England.

Salven, Michael; “Progressive Suspension” Nov. 10, 2000; myTSN—Publication, Netherlands.

Serpent, Veteq; Serpent Model Racing Cars, Noord-Holland, Netherlands; 3 pictures.

Serpent, Veteq; Serpent Model Racing Cars, Noord-Holland, Netherlands; 1 sletch of suspension geometry.

Staniforth, Allan; “Competition Car Suspension” 1988, pp. 76-81, 84-85; Haynes Publications, Newbury Park, California.

Tamiya, “Terra Crusher” model truck; Tamiya America, Inc., Aliso Viejo, California; 1 sketch of suspension geometry.

Traxxas LP; “T-MAXX Assemblies, Front Assembly” exploded view; Traxxas LP, Plano, Texas.

Traxxas, “Nitro Rustler” model vehicle; Traxxas LP, Plano, Texas; 1 photograph.

Traxxas, “T-MAXX” model vehicle; Traxxas LP, Plano, Texas; 1 photograph.

Full size vehicle with suspension linkage #1.

Full size vehicle with suspension linkage #2.

Chassis Shop, “Tube Adapters” Catalog pp. 46-51, Chassis Shop Performance Products, Mears, MI, USA.

Coleman Racing, “Hex Trailing Arm” web pages: [http://www.colemanracing.com/catalog/index.php?cPath=49\\_1024](http://www.colemanracing.com/catalog/index.php?cPath=49_1024) [http://www.colemanracing.com/catalog/product\\_info.php?cPath=49\\_1024&products\\_id=4714](http://www.colemanracing.com/catalog/product_info.php?cPath=49_1024&products_id=4714) Coleman Racing, Memominee, MI, USA.

Traxxas, “T-Maxx Rear Assembly” exploded view drawing; Traxxas LP, Plano, TX, USA.

Aerosticks, “What Are They” web page article, Dec. 26, 2004, DPD Enterprises, Ventura, CA, USA.

Aerosticks, “Fabrication” web page article, Dec. 26, 2004, DPD Enterprises, Ventura, CA, USA.

Aerosticks, “Design Basis” web page article, Jun. 7, 2004, DPD Enterprises, Ventura, CA, USA.

Aerosticks, 2 pages photographs, DPD Enterprises, Ventura, CA, USA.

CN-304138171, posted at Orbit.com, publication date May 17, 2017. Site visited Apr. 12, 2019. Available from Internet. (Year: 2017).

CN-304110963, posted at Orbit.com, publication date Apr. 19, 2017. Site visited Apr. 12, 2019. Available from Internet. (Year: 2017).

ARTINCbydb, Traxxas E-Revo Upper/Lower Arm Replacement, posted at YouTube, posting date Feb. 4, 2013. Site visited Apr. 12, 2019. URL: <<https://www.youtube.com/watch?v=fGMtjrezT0>> (Year: 2013).

Traxxas 5331 Right Front Upper & Lower Arms, posted at Amazon, review posted Dec. 30, 2014. Site visited Apr. 12, 2019. URL <<https://www.amazon.com/Traxxas-Right-Front-Upper-Suspension/dp/B000BOPT0G>> (Year 2014).

Granieri, Luigi, U.S. Pat. No. 903,080, Patented Nov. 3, 1908.

Ewing, Hugh, U.S. Pat. No. 951,000, Patented Mar. 1, 1910.

\* cited by examiner

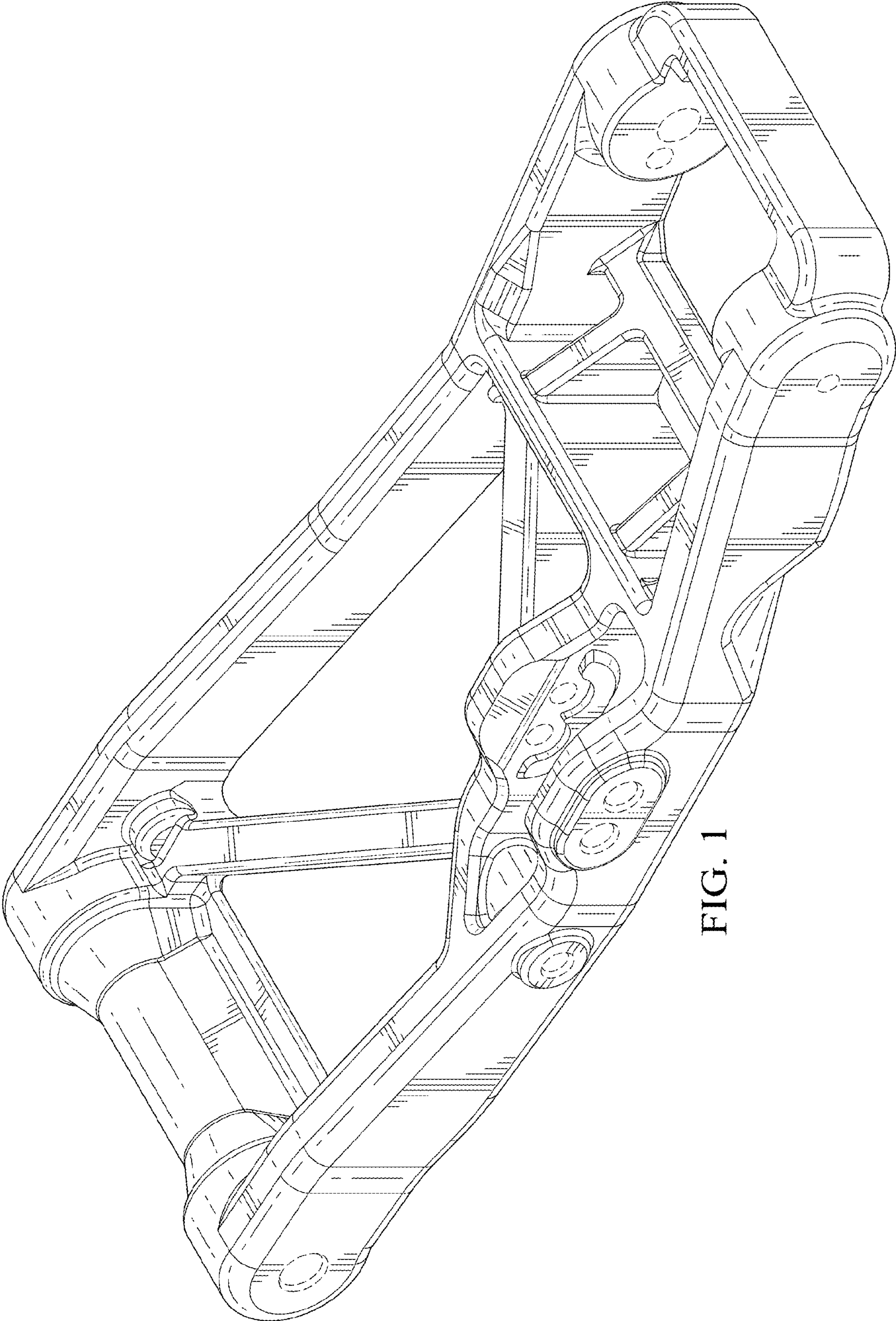

FIG. 1

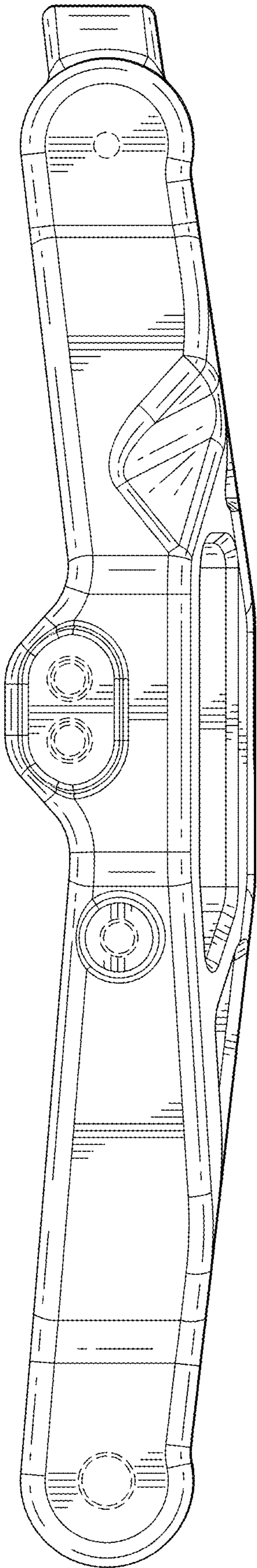

FIG. 2

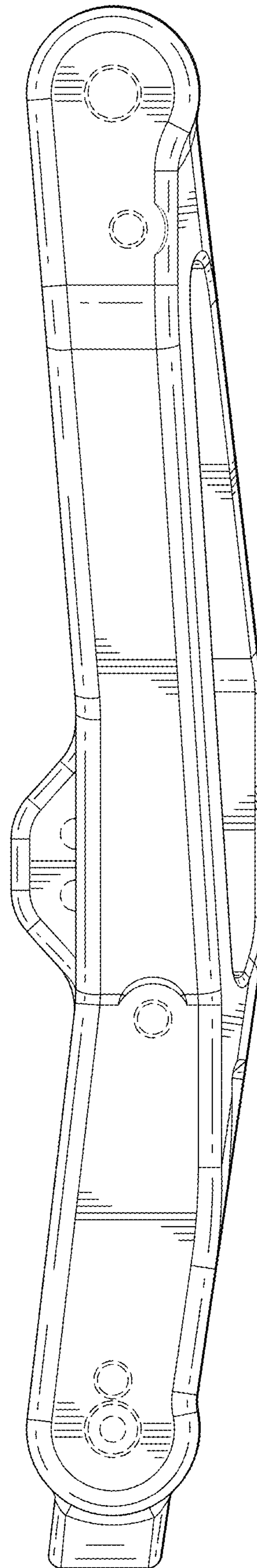

FIG. 3

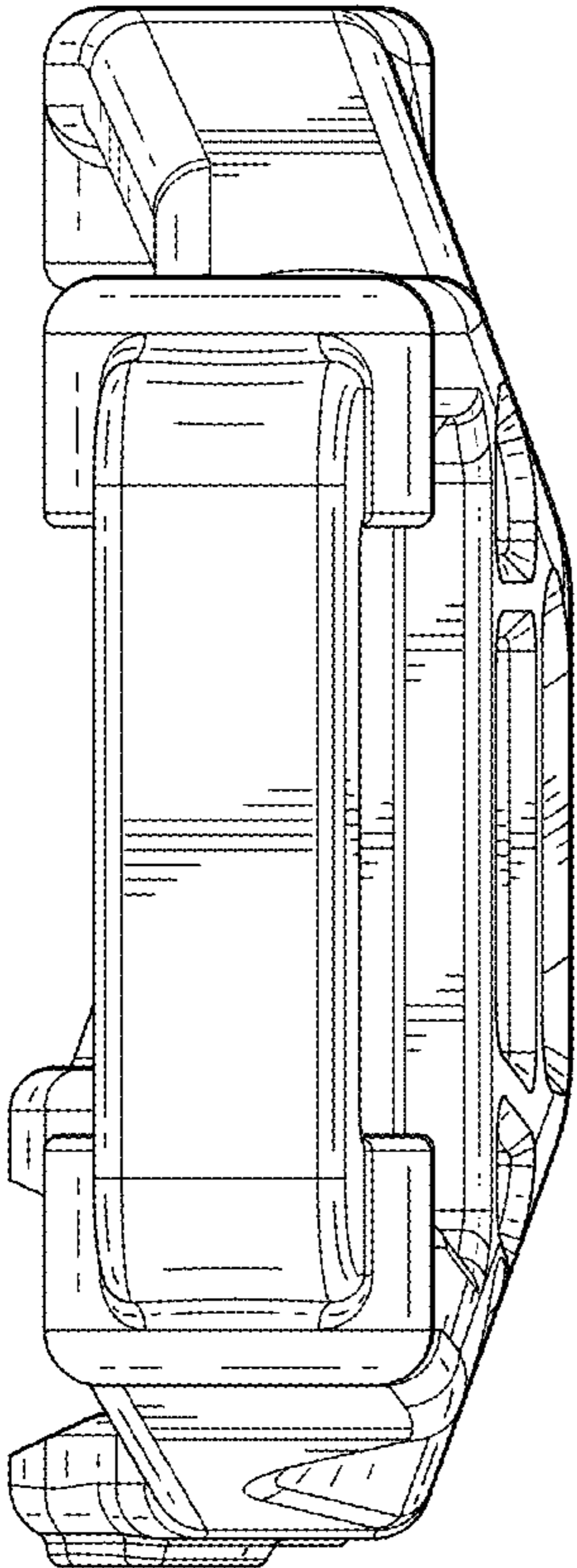

FIG. 4

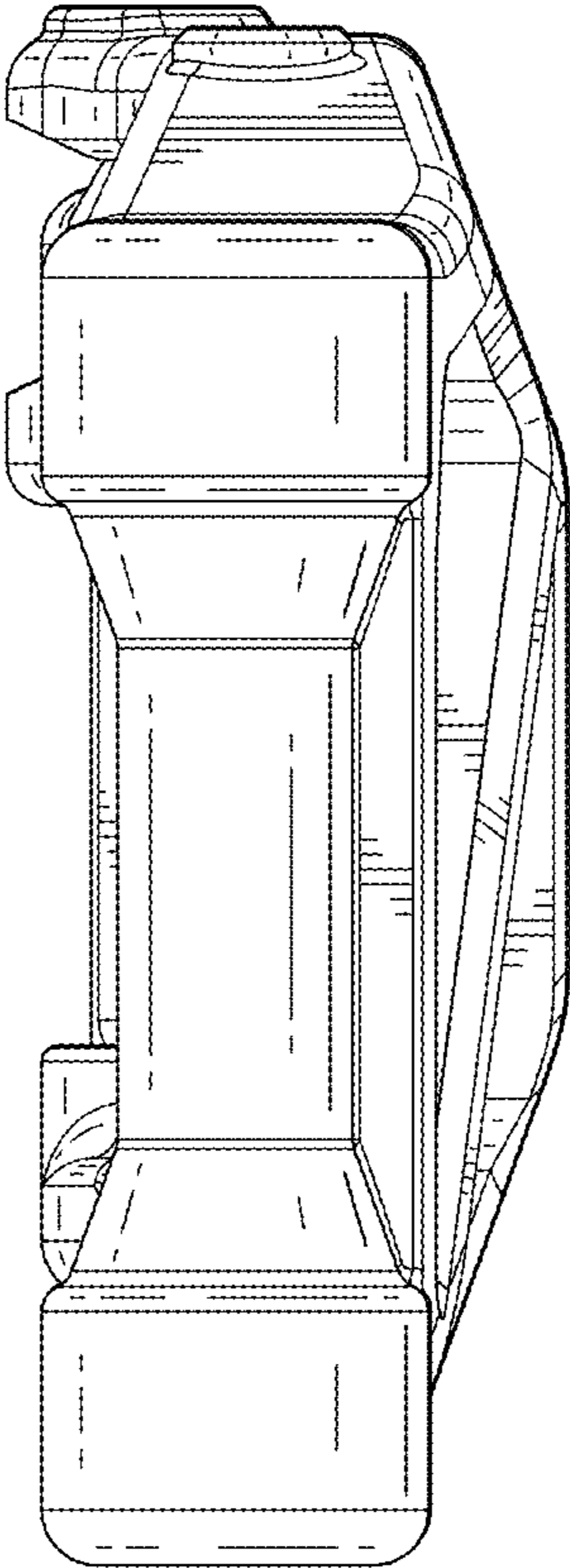

FIG. 5

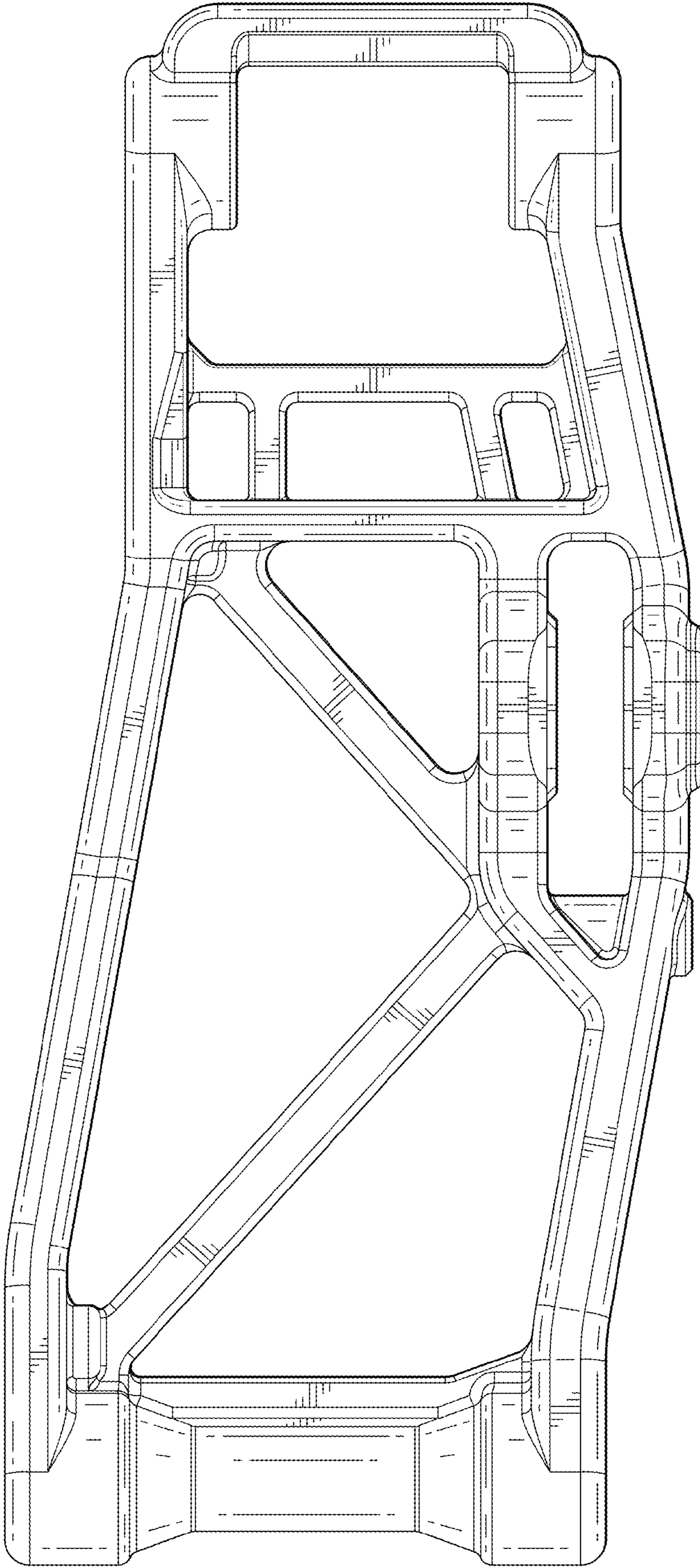

FIG. 6

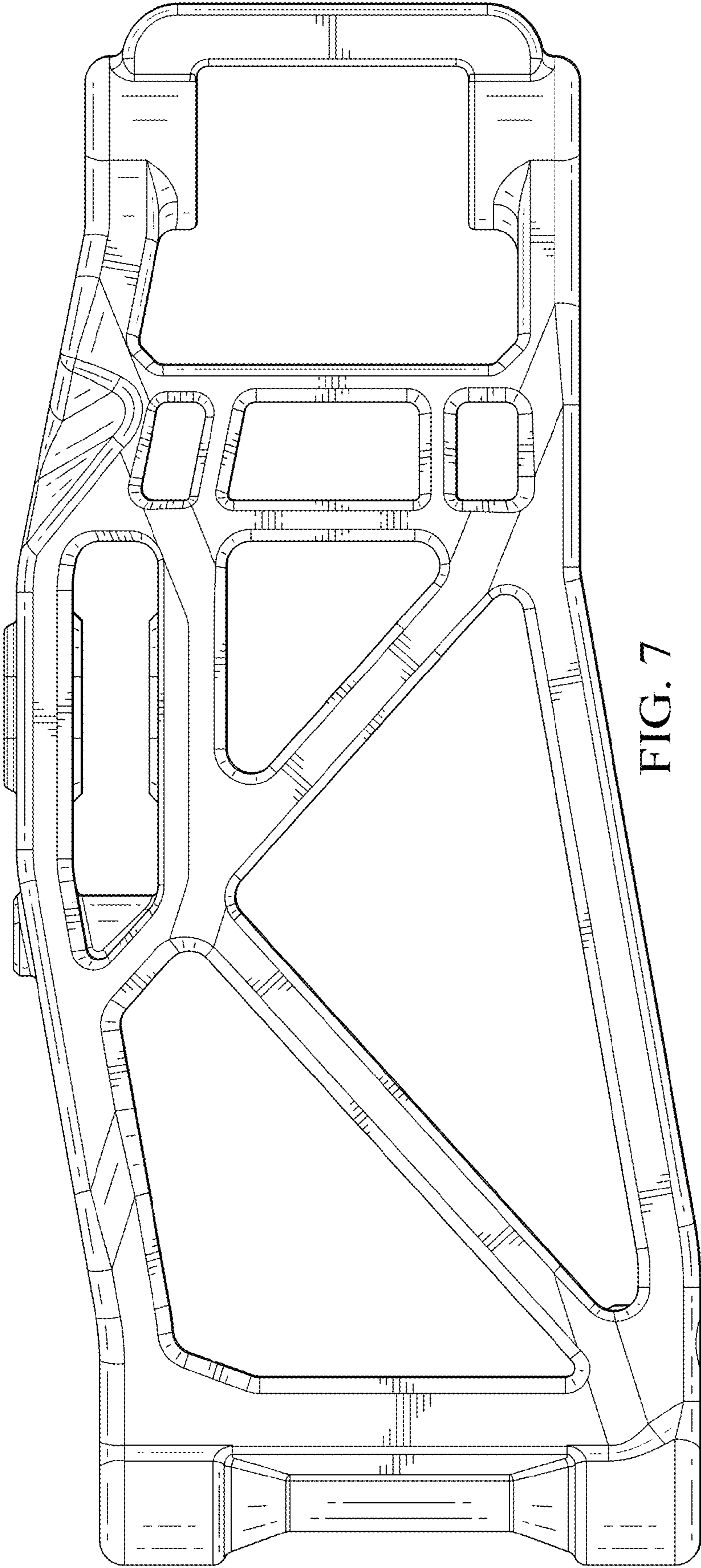

FIG. 7



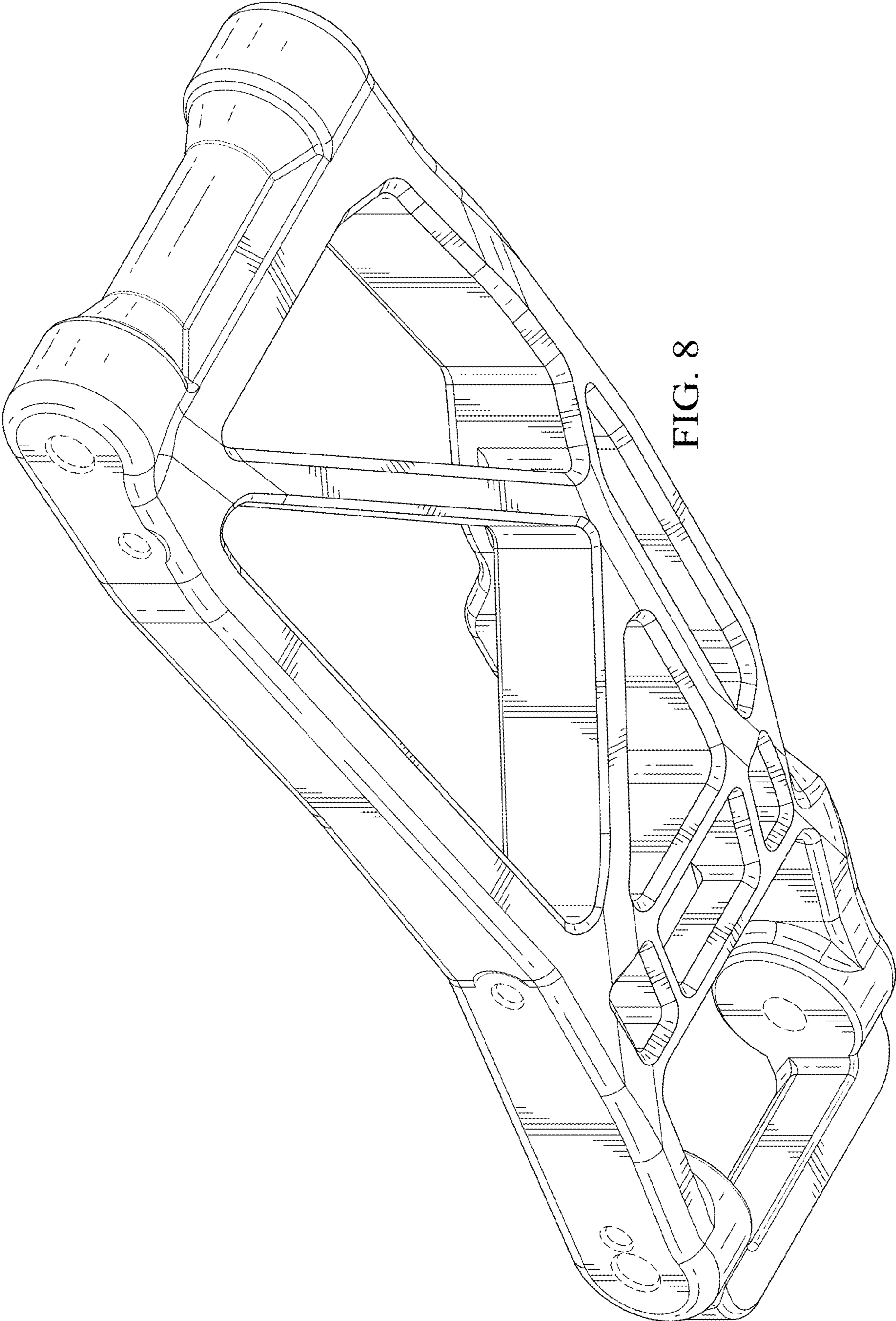

FIG. 8

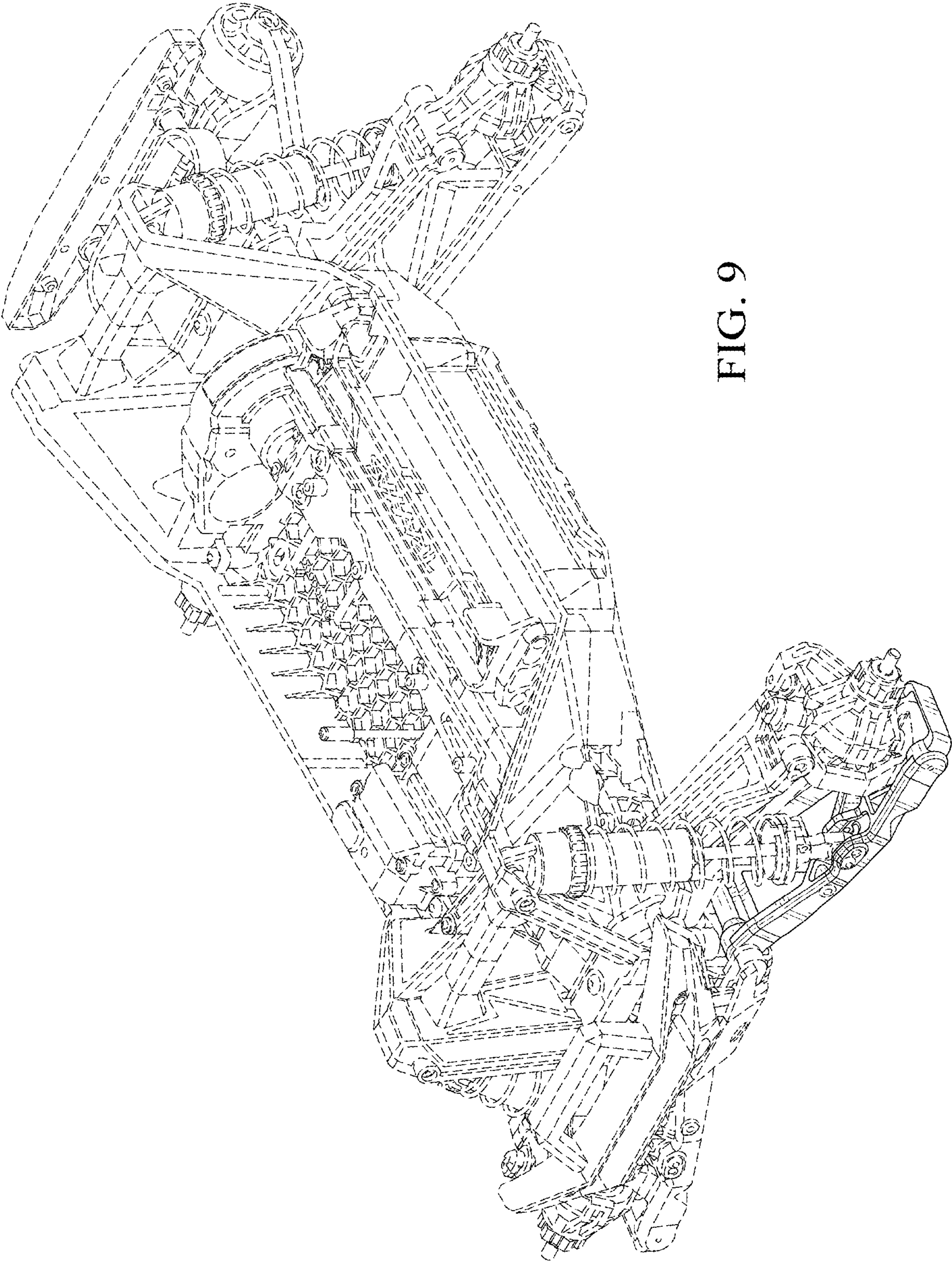

FIG. 9