



US00D905758S

(12) **United States Design Patent** (10) **Patent No.:** **US D905,758 S**  
**Tomczak et al.** (45) **Date of Patent:** **\*\* Dec. 22, 2020**

(54) **ELECTRIC MOTOR STARTER**

(71) Applicant: **Siemens Aktiengesellschaft**, Munich (DE)

(72) Inventors: **Christoph Tomczak**, Erlangen (DE); **Frank Zeitler**, Uttenreuth (DE)

(73) Assignee: **Siemens Aktiengesellschaft**, Munich (DE)

(\*\*) Term: **15 Years**

(21) Appl. No.: **29/648,810**

(22) Filed: **May 24, 2018**

(30) **Foreign Application Priority Data**

Nov. 24, 2017 (EM) ..... 004520963

(51) **LOC (12) Cl.** ..... **15-01**

(52) **U.S. Cl.**  
USPC ..... **D15/5**

(58) **Field of Classification Search**

USPC ..... D15/5; D13/113, 101, 110, 122, 123,  
D13/184, 199, 158, 162, 164; D10/49,  
D10/50

CPC ..... H05K 5/0017; H02P 1/029; H02P 1/42  
See application file for complete search history.

(56) **References Cited**

**U.S. PATENT DOCUMENTS**

D348,674 S \* 7/1994 Lindeman ..... D13/164  
D380,737 S \* 7/1997 Weir ..... D13/162

D381,960 S \* 8/1997 Chandler ..... D10/49  
D503,379 S \* 3/2005 Gheno ..... D13/110  
D590,122 S \* 4/2009 Shaw ..... D34/35  
D675,565 S \* 2/2013 Choi ..... D13/110  
D676,461 S \* 2/2013 Wertz ..... D10/49  
D680,501 S \* 4/2013 Elliott ..... H05K 5/0017  
D771,566 S \* 11/2016 Saarivirta ..... D13/110  
D772,161 S \* 11/2016 Saarivirta ..... D13/110  
D772,162 S \* 11/2016 Saarivirta ..... D13/110  
D821,446 S \* 6/2018 Squire ..... D15/5  
D862,399 S \* 10/2019 Andersson ..... D13/162

\* cited by examiner

*Primary Examiner* — Ania Aman

(74) *Attorney, Agent, or Firm* — Cozen O'Connor

(57) **CLAIM**

The ornamental design for an electric motor starter, as shown and described.

**DESCRIPTION**

FIG. 1 is a front elevational view of an electric motor starter showing our new design;  
FIG. 2 is a rear elevational view thereof;  
FIG. 3 is a top plan view thereof;  
FIG. 4 is a bottom plan view thereof;  
FIG. 5 is a right-side elevation view thereof;  
FIG. 6 is left-side elevation view thereof; and,  
FIG. 7 is a front, top and right-side perspective view thereof.  
The broken lines shown in the drawings are for the purpose of illustrating portions of the article and form no part of the claimed design.

**1 Claim, 7 Drawing Sheets**

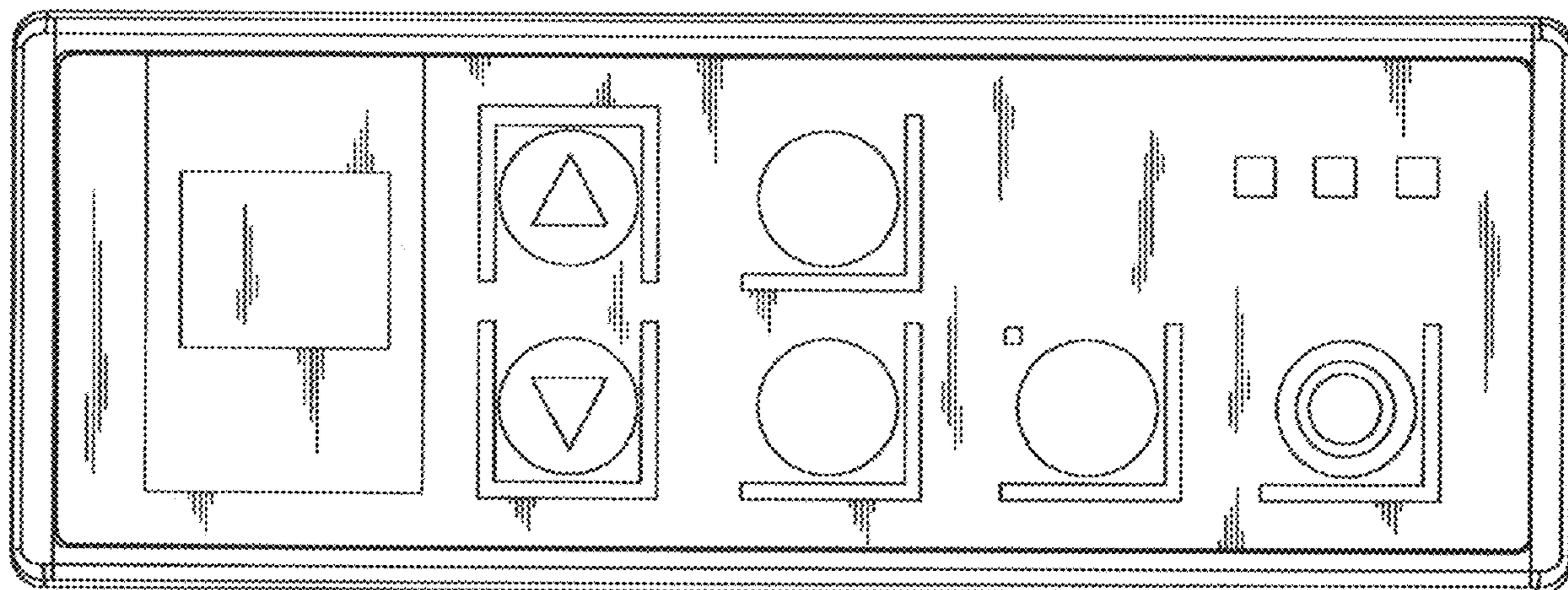

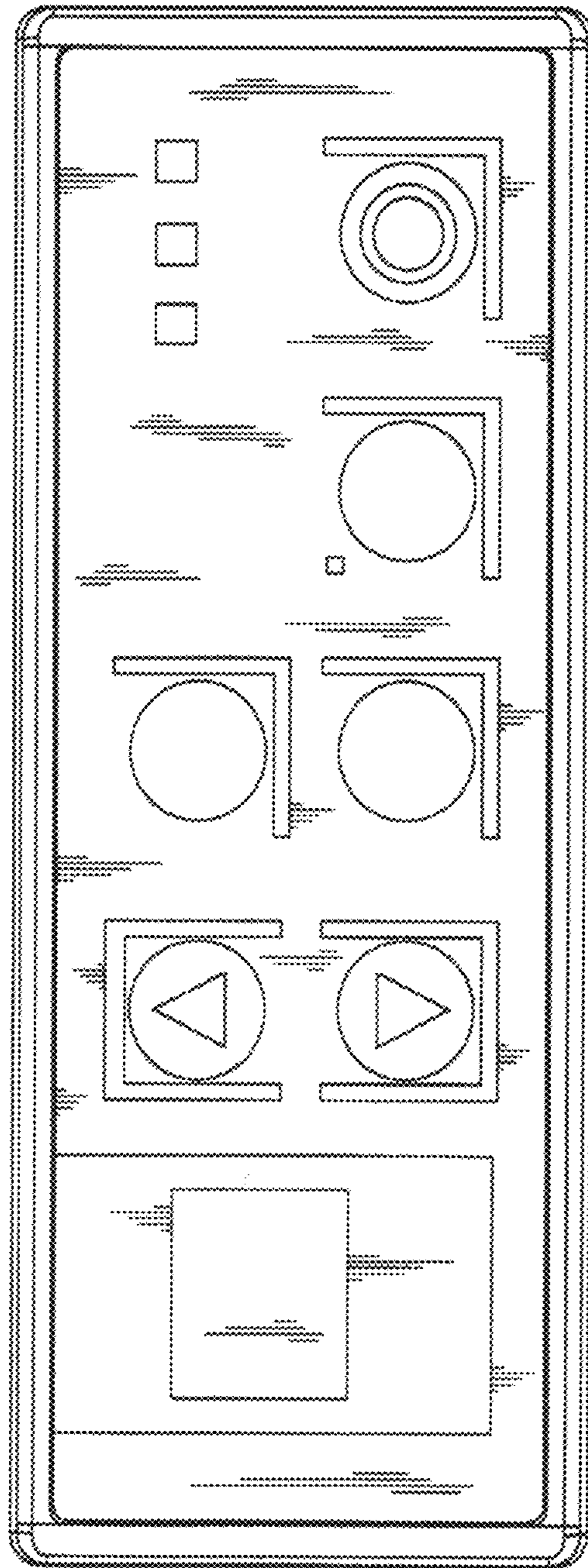

FIG. 1

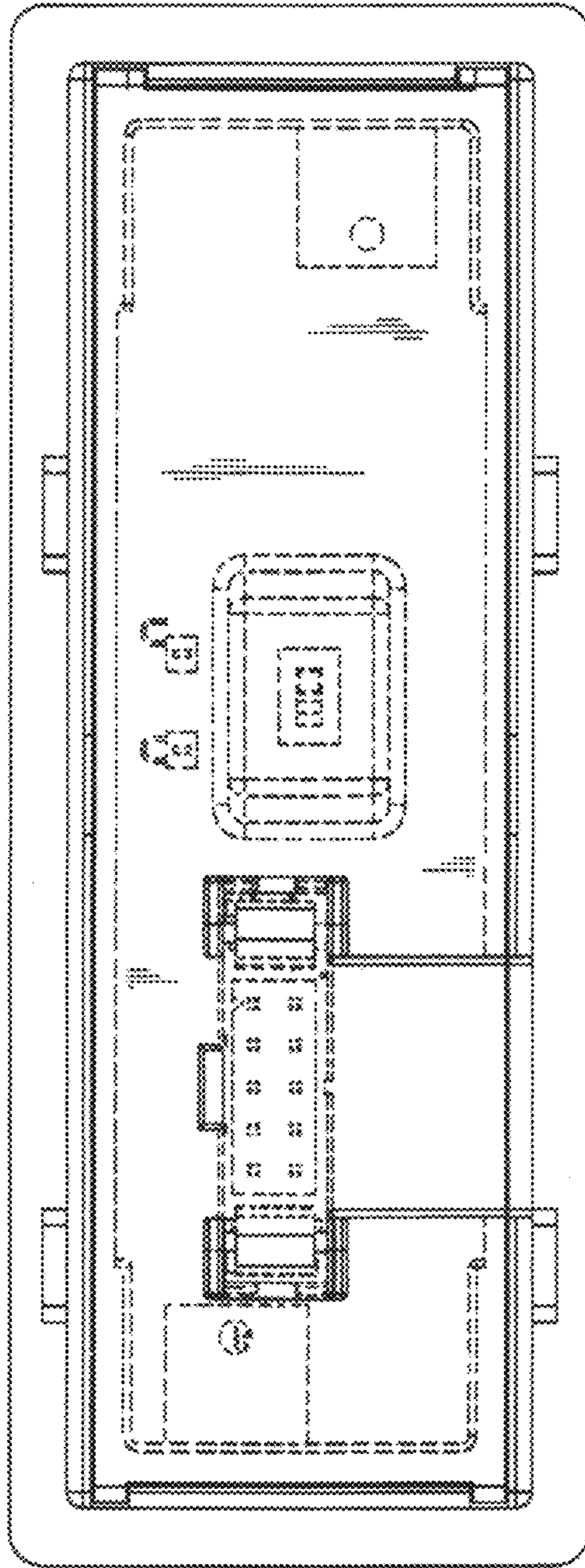

FIG. 2

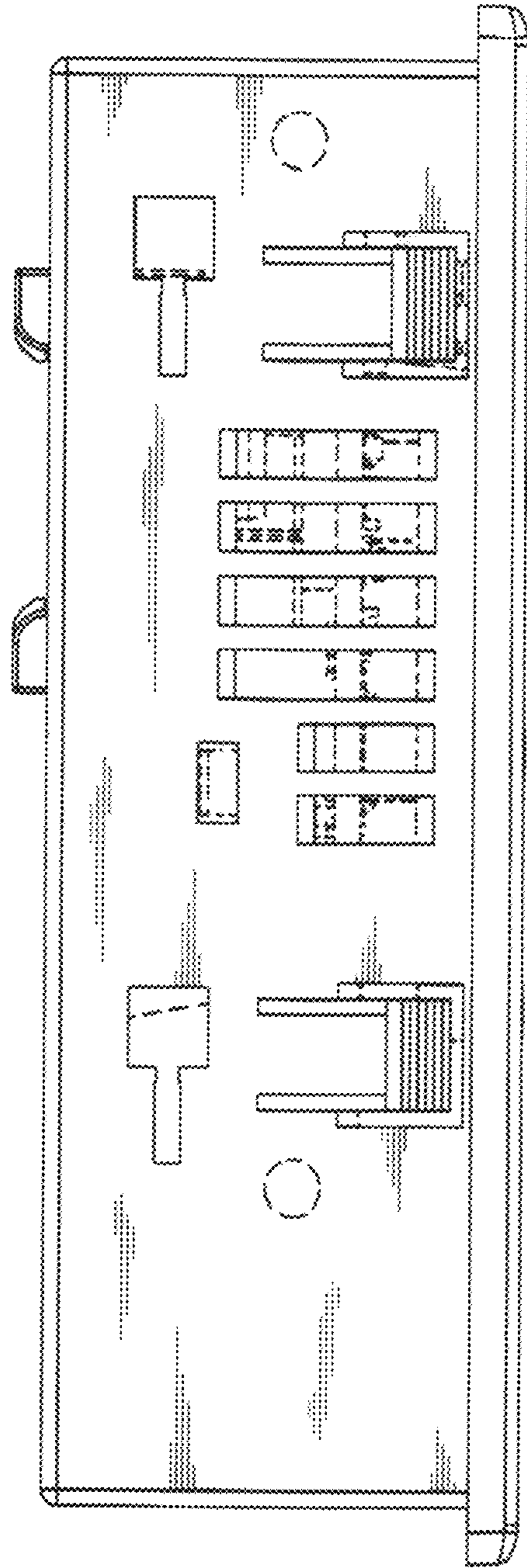

FIG. 3

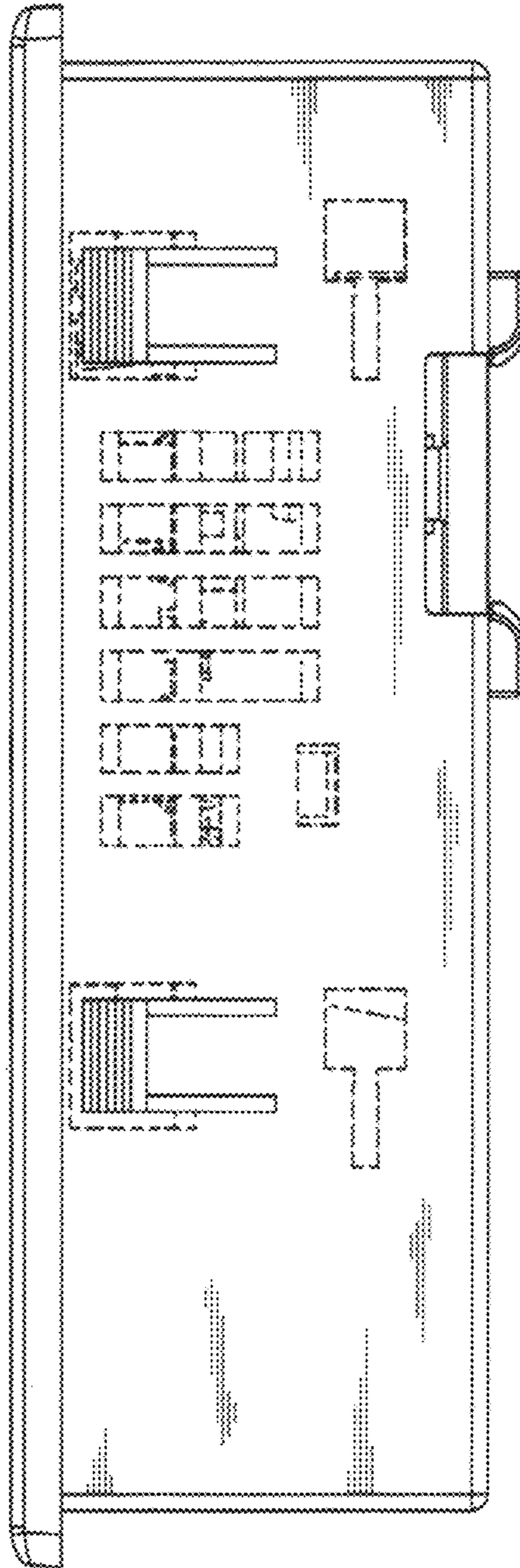

FIG. 4

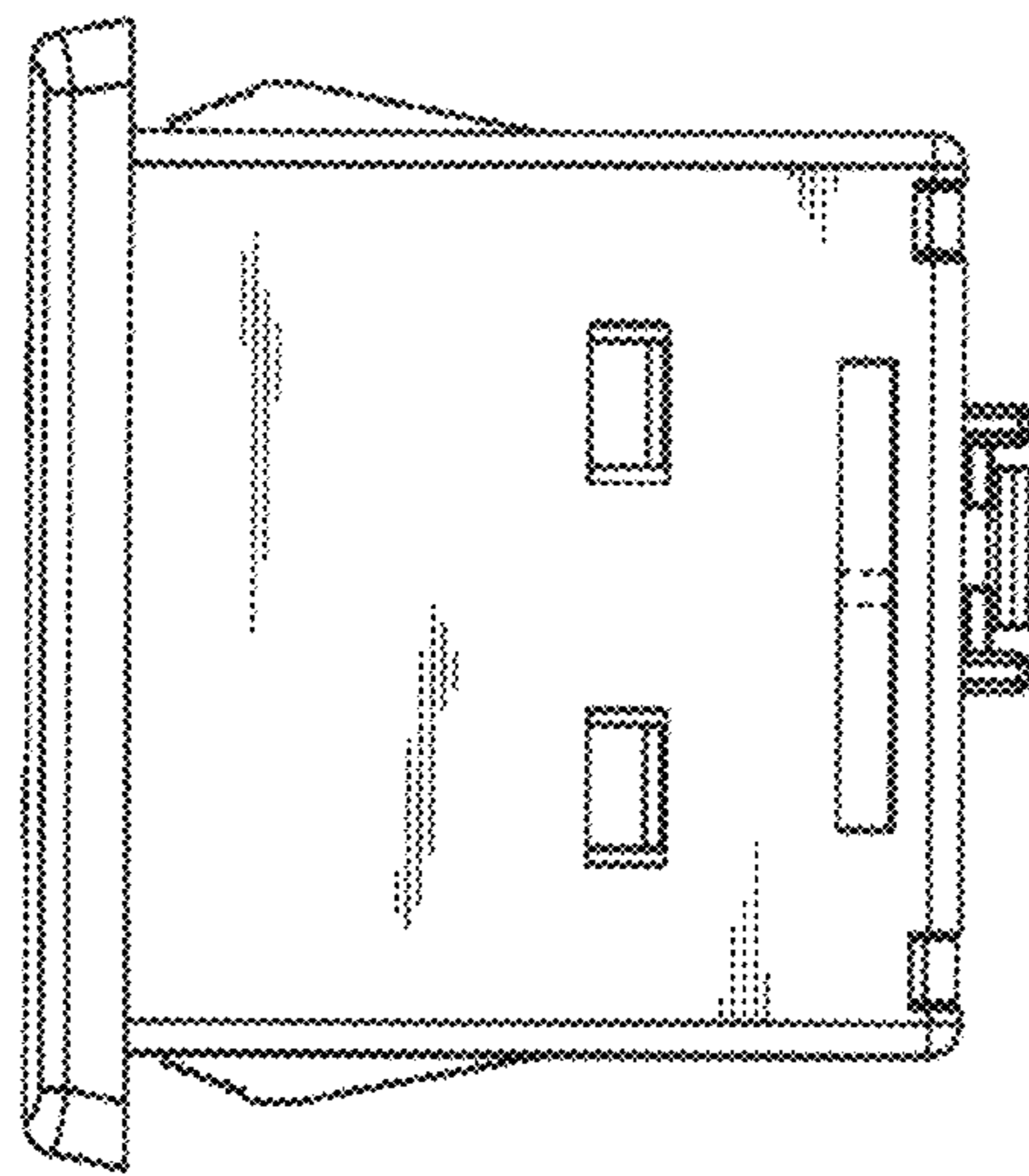

FIG.5

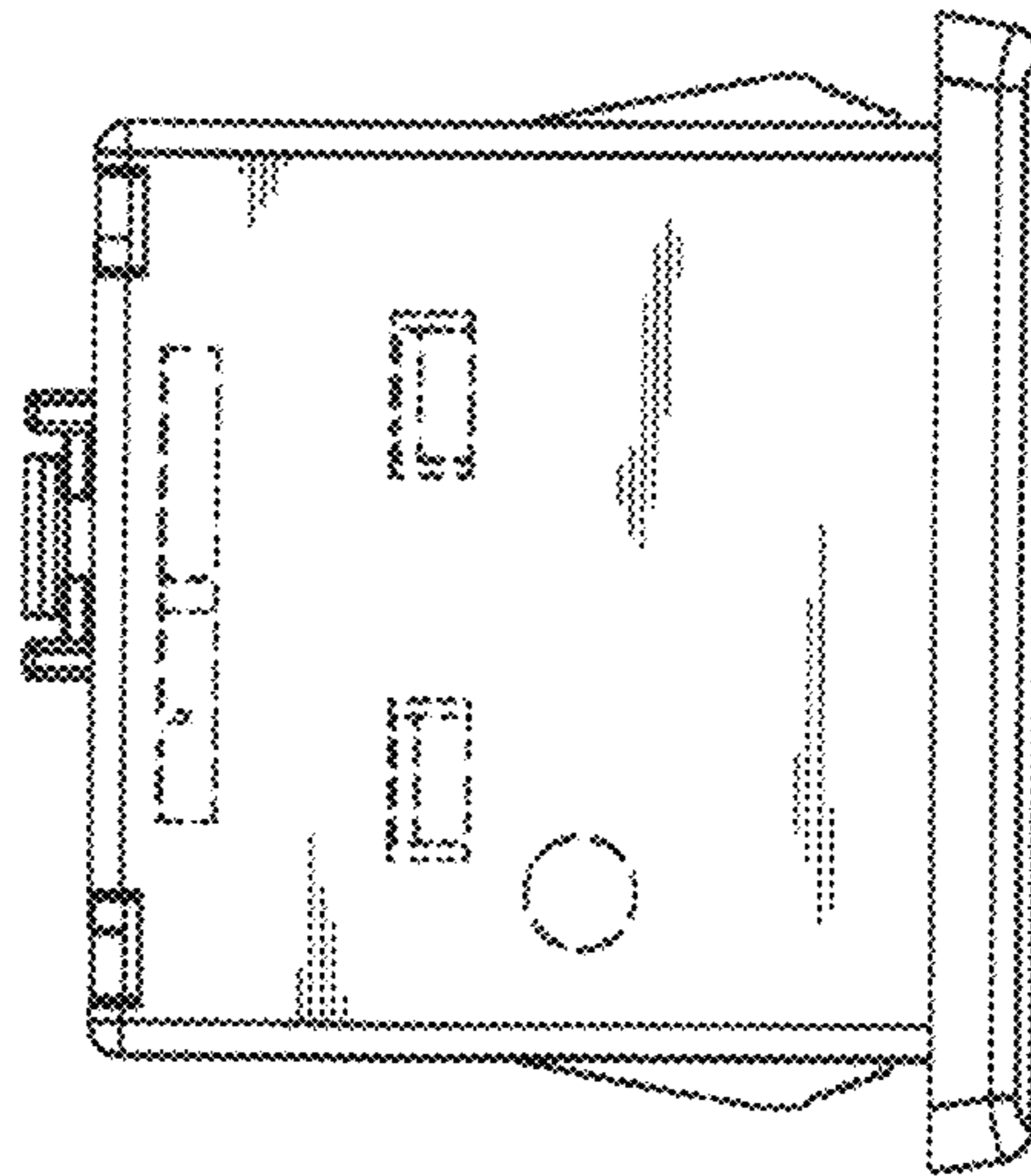

FIG. 6

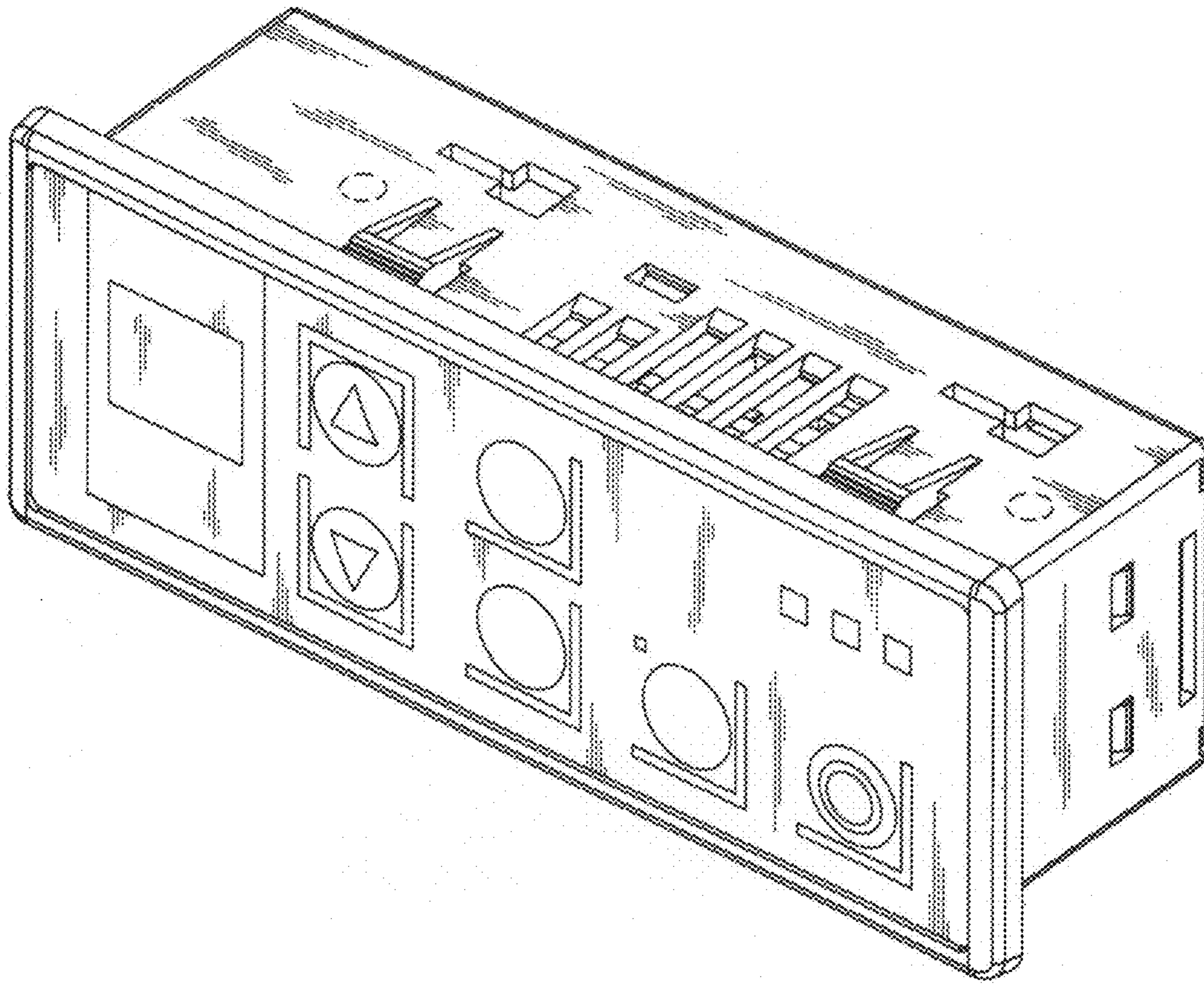

FIG.7