

US00D905675S

(12) **United States Design Patent** (10) **Patent No.:** **US D905,675 S**
Lee (45) **Date of Patent:** **** Dec. 22, 2020**

(54) **CASE FOR ELECTRONIC COMMUNICATIONS DEVICE**

(71) Applicant: **SPIGEN KOREA CO., LTD.**, Seoul (KR)

(72) Inventor: **Jong Hwa Lee**, Seoul (KR)

(73) Assignee: **SPIGEN KOREA CO., LTD.**, Seoul (KR)

(**) Term: **15 Years**

(21) Appl. No.: **29/696,163**

(22) Filed: **Jun. 25, 2019**

(51) **LOC (12) Cl.** **14-03**

(52) **U.S. Cl.**
 USPC **D14/250**

(58) **Field of Classification Search**
 USPC D14/250, 440, 203.3-203.7, 439, 238.1, D14/251-253, 447, 217, 240, 248; D3/201, 218, 247, 269, 273, 301, 303; D13/103, 119, 107-108
 CPC H04B 1/3888; H04M 1/0283; H04M 1/0202; A45C 1/06; A45C 11/00; A45C 13/02; A45C 2011/002; A45F 2005/026; A45F 2200/0525; A45F 2200/0516
 See application file for complete search history.

D614,668 S 4/2010 Jones
 D619,361 S 7/2010 Andre
 D624,908 S 10/2010 Huskinson
 D636,387 S 4/2011 Willes
 D637,589 S 5/2011 Willes et al.
 D646,265 S 10/2011 Fathollahi
 D657,354 S 4/2012 Kim
 D663,294 S 7/2012 Buxton
 D673,547 S 1/2013 Melanson et al.
 D676,035 S 2/2013 Chang
 D679,271 S 4/2013 Liu
 D681,054 S * 4/2013 Koh D14/496
 D681,615 S 5/2013 Fathollahi
 8,517,172 B1 8/2013 Chang
 D693,820 S * 11/2013 Eastwood D14/432
 D696,256 S 12/2013 Piedra et al.
 D702,673 S 4/2014 Murchison et al.
 8,706,176 B1 4/2014 Jia
 D705,534 S * 5/2014 Manjerico D3/218
 D706,254 S 6/2014 Chang
 D707,670 S 6/2014 Chang et al.
 D709,871 S 7/2014 Lee
 D714,053 S * 9/2014 Yoo D3/269
 8,854,834 B2 * 10/2014 O'Connor G06F 1/1641 361/807
 D716,751 S * 11/2014 Lee D14/138 AB
 D718,758 S 12/2014 Jaffee
 D721,071 S 1/2015 Nelson
 D729,812 S * 5/2015 Ahn D14/440
 D733,111 S 6/2015 Kim
 9,049,283 B1 6/2015 Kim
 D733,714 S 7/2015 Ballou et al.
 9,185,954 B2 11/2015 Cheung
 D744,491 S * 12/2015 Lee D14/440
 D745,013 S * 12/2015 Brierley D14/440
 D749,068 S 2/2016 Zaborski
 D749,535 S 2/2016 Joung
 D749,594 S 2/2016 Kim
 D753,099 S 4/2016 Kim
 D755,168 S * 5/2016 Kim D14/250
 D755,764 S 5/2016 Dong
 D755,772 S 5/2016 Sasaki
 D756,339 S 5/2016 Tussy
 D756,340 S 5/2016 Babichenko
 D756,342 S 5/2016 Lee et al.
 D756,343 S 5/2016 Wall et al.
 D756,909 S 5/2016 Gupta
 D756,977 S 5/2016 Schriefer
 D756,978 S 5/2016 Addonisio
 D756,980 S 5/2016 Beeman
 D757,703 S 5/2016 Kanazawa
 D759,641 S 6/2016 Lai et al.
 D759,642 S 6/2016 Chao

(56) **References Cited**
 U.S. PATENT DOCUMENTS

6,758,335 B2 7/2004 Kajiya
 D517,545 S 3/2006 Buckel et al.
 7,032,984 B2 * 4/2006 Kim G06F 1/1601 312/223.2
 D524,806 S 7/2006 Eguchi
 7,155,266 B2 * 12/2006 Stefansen H04M 1/022 455/575.3
 D551,846 S 10/2007 Ko et al.
 D559,843 S 1/2008 Takamori et al.
 D560,216 S 1/2008 Takamori et al.
 D613,761 S 4/2010 Jones
 D613,762 S 4/2010 Jones
 D613,763 S 4/2010 Jones

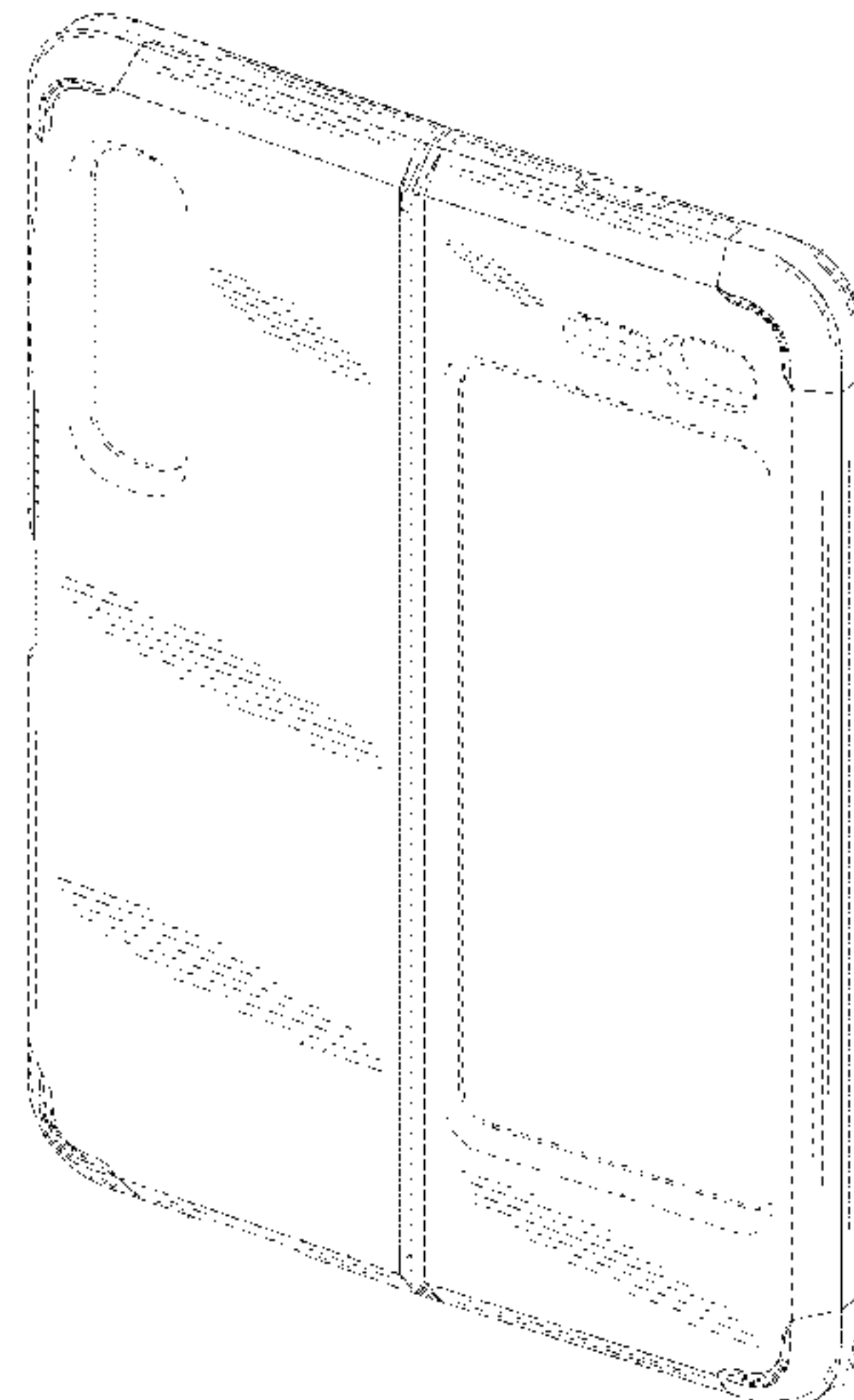

D762,633	S	8/2016	Fife	
D763,839	S	8/2016	Shin et al.	
D765,634	S	9/2016	McCray	
D765,635	S	9/2016	Chang	
D765,638	S	9/2016	Gaylord	
D765,640	S	9/2016	Bulkley	
D768,615	S	10/2016	Wang	
9,467,189	B2	10/2016	Day et al.	
D771,028	S	11/2016	Kim	
D771,068	S	11/2016	Kim et al.	
D771,608	S	11/2016	Kim	
D772,209	S	11/2016	Kim	
D772,214	S	* 11/2016	Daniel	D14/250
D772,858	S	11/2016	Hu	
D772,881	S	11/2016	Chang et al.	
9,503,147	B2	11/2016	Witter et al.	
D775,620	S	1/2017	Kim	
D776,104	S	1/2017	Tien	
D776,648	S	1/2017	Kim	
D776,649	S	1/2017	Kim	
D777,155	S	1/2017	Kim	
D777,156	S	1/2017	Kim	
D777,159	S	* 1/2017	Lee	D14/250
D777,160	S	1/2017	Kim	
9,545,140	B1	1/2017	Johnson et al.	
D778,897	S	2/2017	Kim	
D778,898	S	2/2017	Kim	
D780,166	S	2/2017	Lin	
D780,167	S	2/2017	Tien	
D786,233	S	5/2017	Kim	
D786,851	S	5/2017	Kim	
D786,852	S	5/2017	Kim	
D787,491	S	5/2017	Kim	
D787,492	S	5/2017	Kim	
D787,942	S	5/2017	Kim	
D788,090	S	5/2017	Kim	
D788,757	S	6/2017	Kim	
D789,344	S	6/2017	Kim	
D791,755	S	7/2017	Kim	
D795,826	S	* 8/2017	Yoon	D14/138
D796,497	S	9/2017	Kim	
D798,257	S	* 9/2017	Choo	D14/138 AB
D798,284	S	9/2017	Kim	
D800,112	S	* 10/2017	Park	D14/345
D800,713	S	10/2017	Kim	
D800,732	S	10/2017	Dang et al.	
D803,206	S	11/2017	Kim	
D806,378	S	* 1/2018	Lerenthal	D3/201
D807,368	S	1/2018	Stewart et al.	
D808,955	S	1/2018	Park	
D810,065	S	2/2018	Tien et al.	
D810,066	S	2/2018	Tien et al.	
D810,067	S	* 2/2018	Lee	D14/250
D810,726	S	2/2018	Chou et al.	
D813,854	S	3/2018	Lee et al.	
D814,455	S	* 4/2018	Kwon	D14/341
D823,293	S	7/2018	Kim et al.	
D823,296	S	7/2018	Kim et al.	
D823,297	S	7/2018	Kim et al.	
D823,298	S	7/2018	Kim et al.	
10,064,298	B2	* 8/2018	Cavenagh	H05K 5/0004
D832,245	S	* 10/2018	Jeon	D14/250
D832,268	S	10/2018	Mecchella et al.	
D835,089	S	12/2018	Nelson et al.	
10,162,389	B2	* 12/2018	Tazbaz	G06F 1/1681
D837,795	S	1/2019	Stewart et al.	
D839,274	S	1/2019	Stewart	
D840,393	S	2/2019	Kim et al.	
D841,646	S	2/2019	Son et al.	
2009/0017883	A1	1/2009	Lin	
2011/0050606	A1	3/2011	Zhang	
2013/0077211	A1	3/2013	Wang	
2013/0126531	A1	5/2013	Hynecek	
2014/0262855	A1	9/2014	Gandhi	
2014/0290009	A1	* 10/2014	Kasai	E05D 3/12 16/386
2014/0360892	A1	12/2014	Lin	
2015/0156297	A1	6/2015	Crawford	
2015/0335116	A1	11/2015	Kim	

2015/0370287	A1*	12/2015	Ko	G06F 1/1626 361/749
2016/0028430	A1	1/2016	Crawford		
2016/0187935	A1*	6/2016	Tazbaz	G06F 1/163 361/679.03

OTHER PUBLICATIONS

This is what folding phone cases will look like, Spigen reveals its first models, publication date Mar. 1, 2019, [online][site visited Jun. 12, 2019] URL: <https://www.theverge.com/2019/3/1/18246183/samsung-galaxy-fold-foldable-phone-case-screen-protector-spigen-zagg> (Year: 2019).*

“Spigen Tough Armor iPhone SE/5S/5 Case with Extreme Heavy Duty Protection and Air Cushion Technology for iPhone SE/iPhone 5S/iPhone 5—Metal Slate”, <https://www.amazon.com/Spigen-Extreme-Protection-Cushion-Technology/dp/B00DMKGPP4>, Earliest review date of Aug. 1, 2013, Downloaded on Aug. 9, 2018.

“Spigen Tough Armor Designed for Apple iPad Mini 3 Case, iPad Mini 2 Case, iPad Mini Case—Metal Slate”, <https://www.amazon.com/Spigen-Tough-Armor-Designed-Apple/dp/B00FRVDVXK>, Earliest review date of Dec. 27, 2013, Downloaded on Jan. 15, 2019.

“Spigen Tough Armor Galaxy S5 Case with Extreme Heavy Duty Protection and Air Cushion Technology for Samsung Galaxy S5 2014—Gunmetal”, <https://www.amazon.com/Spigen-Extreme-Protection-Cushion-Technology/dp/B00I3UWDV8>, Earliest review date of Mar. 9, 2014, Downloaded on Aug. 9, 2018.

“Spigen Tough Armor iPhone 6 Plus Case with Kickstand and Extreme Heavy Duty Protection and Air Cushion Technology for iPhone 6S Plus / iPhone 6 Plus—Gunmetal”, <https://www.amazon.com/dp/B00LL987W2>, Earliest review date of Jul. 8, 2014, Downloaded on Oct. 4, 2017.

“Spigen Tough Armor iPhone 6 Case with Extreme Heavy Duty Protection and Air Cushion Technology for iPhone 6S/iPhone 6—Smooth Black”, <https://www.amazon.com/Spigen-Extreme-Protection-Cushion-Technology/dp/B00NSSX23I>, Earliest review date of Aug. 14, 2014, Downloaded on Aug. 9, 2018.

“Spigen Tough Armor iPhone 6 Case with Extreme Heavy Duty Protection and Air Cushion Technology for iPhone 6S / iPhone 6—Gunmetal”, <https://www.amazon.com/Spigen-Extreme-Protection-Cushion-Technology/dp/B00LL60JU8>, Earliest review date of Sep. 10, 2014, Downloaded on Jan. 15, 2019.

“Spigen Tough Armor S iPhone 6 Case with Extreme Heavy Duty Protection and Card Kickstand Feature for iPhone 6S / iPhone 6—S Mint”, <https://www.amazon.com/Spigen-Extreme-Protection-Kickstand-Feature/dp/B00LL65B06>, Earliest review date of Sep. 18, 2014, Downloaded on Jan. 15, 2019.

“Spigen Tough Armor Galaxy Note 4 Case with Extreme Heavy Duty Protection and Air Cushion Technology for Samsung Galaxy Note 4 2014—Gunmetal”, <https://www.amazon.com/dp/B00MAWQU14>, Earliest review date of Oct. 9, 2014, Downloaded on Aug. 31, 2018.

“Spigen Tough Armor FX iPhone 6 Case with Extreme Protection and Front Built-In Screen Protector Cover for iPhone 6S / iPhone 6—Gunmetal”, <https://www.amazon.com/Spigen-iPhone-Extreme-Protection-Protector/dp/B00PR9XE5C>, Earliest review date of Jan. 8, 2015, Downloaded on Jan. 15, 2019.

“Spigen Tough Armor Galaxy S6 Edge Case with Kickstand and Extreme Heavy Duty Protection and Air Cushion Technology for Galaxy S6 Edge 2015—Gunmetal”, <https://www.amazon.com/dp/B00SV63L38>, Earliest review date of Mar. 12, 2015, Downloaded on Aug. 9, 2018.

“Spigen Tough Armor Galaxy S6 Case with Kickstand and Air Cushion Techonology for Galaxy S6 2015—Gunmetal”, <https://www.amazon.com/dp/B00QU4PUKK>, Earliest review date of Mar. 23, 2015, Downloaded on Aug. 9, 2018.

“Spigen Tough Armor iPhone 6S Case with Extreme Heavy Duty Protection and Air Cushion Technology for iPhone 6S/iPhone 6—Rose Gold”, <https://www.amazon.com/dp/B013TKNNGK>, Earliest review date of Aug. 30, 2015, Downloaded on Aug. 8, 2018.

“Spigen Tough Armor iPhone 6S Plus Case with Kickstand and Heavy Duty Air Cushion Technology Protection for iPhone 6S Plus/iPhone 6 Plus Only—Gunmetal”, <https://www.amazon.com/Spigen-Kickstand-Cushion-Technology-Protection/dp/B010MVQJPQ>, Earliest review date of Sep. 9, 2015, Downloaded on Aug. 9, 2018.

“Spigen Tough Armor Galaxy S7 Edge Case with Kickstand and Extreme Heavy Duty Protection and Air Cushion Technology for Samsung Galaxy S7 Edge 2016—Gunmetal”, <https://www.amazon.com/dp/B01A7IDNWQ>, Earliest review date of Feb. 24, 2016, Downloaded on Aug. 9, 2018.

“Spigen Tough Armor Galaxy S7 Case with Extreme Heavy Duty Protection and Air Cushion Technology for Samsung Galaxy S7 2016—Gunmetal”, <https://www.amazon.com/dp/B01A7ID3PS>, Earliest review date of Feb. 25, 2016, Downloaded on Aug. 9, 2018.

“Spigen Tough Armor LG G5 Case with Reinforced Kickstand and Heavy Duty Protection and Air Cushion Technology for LG G5 (2016)—Gunmetal”, <https://www.amazon.com/dp/B01B1GQL6L>, Earliest review date of Mar. 11, 2016, Downloaded on Aug. 9, 2018.

“Spigen Tough Armor iPhone SE Case with Extreme Heavy Duty Protection and Air Cushion Technology for iPhone SE 2016—Black”, <https://www.amazon.com/Spigen-Extreme-Protection-Cushion-Technology/dp/B01BEJB9XM>, Earliest review date of Apr. 7, 2016, Downloaded on Aug. 9, 2018.

“Spigen Tough Armor Heavy Duty Extreme Protection Rugged Slim Dual Layer Protective Cover Case for Apple iPhone 7—Gunmetal”, <https://www.amazon.co.uk/dp/B01GIVWY30>, Date first available at Amazon.co.uk of Aug. 2, 2016, Downloaded on Sep. 17, 2018.

“Spigen Tough Armor iPhone 7 Plus / iPhone 8 Plus Case with Extreme Heavy Duty Protection and Air Cushion Technology with Kickstand for Apple iPhone 7 Plus 2016 / iPhone 8 Plus 2017—Rose Gold”, <https://www.amazon.com/dp/B01GIWGE8A>, Earliest review date of Sep. 6, 2016, Downloaded on Aug. 9, 2018.

“Spigen Tough Armor iPhone 7 Case with Extreme Heavy Duty Protection and Air Cushion Technology for iPhone 7 2016—Black”, <https://www.amazon.com/dp/B01GIVX30I>, Earliest review date of Sep. 9, 2016, Downloaded on Aug. 9, 2018.

“Spigen Tough Armor iPhone 7 Case with Jet Black Optimized Color and Extreme Heavy Duty Protection and Air cushion Technology for iPhone 7 2016—Jet Black”, <https://www.amazon.com/Spigen-Optimized-Extreme-Protection-Technology/dp/B01LRSFLFM>, Earliest review date of Sep. 25, 2016, Downloaded on Aug. 9, 2018.

“Spigen Tough Armor Google Pixel Case with Kickstand and Heavy Duty Air Cushion Technology Protection for Google Pixel 2016—Black”, <https://www.amazon.com/Spigen-Kickstand-Cushion-Technology-Protection/dp/B01M12Z4PY>, Earliest review date of Oct. 20, 2016, Downloaded on Aug. 9, 2018.

“Spigen Tough Armor Google Pixel XL Case with Kickstand and Heavy Duty Air Cushion Technology Protection for Google Pixel XL 2016—Gunmetal”, <https://www.amazon.com/Spigen-Kickstand-Cushion-Technology-Protection/dp/B01LZGCH6E>, Earliest review date of Oct. 21, 2016, Downloaded on Aug. 9, 2018.

“Spigen Tough Armor LG V20 Case with Kickstand and Extreme Heavy Duty Protection and Air Cushion Technology for LG V20—Gunmetal”, <https://www.amazon.com/Spigen-Kickstand-Extreme-Protection-Technology/dp/B01M9FI54B>, Earliest review date of Dec. 2, 2016, Downloaded on Aug. 9, 2018.

“Spigen Tough Armor Designed for Apple Watch Case for 42mm Series 3 / Series 2/1 / Original (2015) / Nike+ Sport Edition and Built in Screen Protector—Gunmetal”, <https://www.amazon.com/dp/B01N74P26H>, Earliest review date of Jan. 4, 2017, Downloaded on Jan. 15, 2019.

“Spigen Tough Armor LG G6 Case with Extreme Heavy Duty Protection and Air Cushion Technology for LG G6 (2017)—Black”, <https://www.amazon.com/dp/B01MR8C4RY>, Earliest review date of Mar. 26, 2017, Downloaded on Aug. 3, 2018.

“Spigen Tough Armor Galaxy S8 Plus Case with Reinforced Kickstand and Heavy Duty Protection and Air Cushion Technology for Samsung Galaxy S8 Plus (2017)—Black”, <https://www.amazon.com/dp/B06XP4FP8N>, Earliest review late of Apr. 8, 2017, Downloaded on Aug. 9, 2018.

“Spigen Tough Armor Galaxy S8 Case with Kickstand and Extreme Heavy Duty Protection and Air Cushion Technology for Samsung Galaxy S8 (2017)—Black”, <http://www.amazon.com/dp/B0716CZ3Z1>, Earliest review date of Apr. 9, 2017, downloaded on Aug. 9, 2018.

“Spigen Tough Armor [2nd Generation] iPhone 8 Plus Case/iPhone 7 Plus Case with Kickstand Air Cushion Technology for Apple iPhone 8 Plus (2017) / iPhone 7 Plus (2016)—Black”, <http://www.amazon.com/dp/B07482KRLP>, Earliest review date of Aug. 8, 2018, downloaded on Jan. 15, 2019.

“Spigen Tough Armor [2nd Generation] iPhone 8 Plus Case/iPhone 7 Plus Case with Kickstand Air Cushion Technology for Apple iPhone 8 Plus (2017)/iPhone 7 Plus (2016)—Rose Gold”, <http://www.amazon.com/dp/B074826HMD>, Earliest review date of Aug. 18, 2017, downloaded on Aug. 9, 2018.

“Spigen Tough Armor Galaxy Note 8 Case with Kickstand and Extreme Heavy Duty Protection and Air Cushion Technology for Galaxy Note 8 (2017)—Orchid Gray”, <http://www.amazon.com/dp/B073R7MND3>, Earliest review date of Aug. 26, 2017, downloaded on Aug. 9, 2018.

“Spigen Tough Armor [2nd Generation] iPhone 8 Case/iPhone 7 Case with Kickstand and Heavy Duty Protection and Air Cushion Technology for Apple iPhone 8 (2017)/iPhone 7 (2016)—Gunmetal”, <http://www.amazon.com/dp/B07482KVD3>, Earliest review date of Sep. 2, 2017, downloaded on Aug. 9, 2018.

“Spigen Tough Armor LG V30 Case with Kickstand and Heavy Duty Protection for LG V30 (2017)—Black”, <http://www.amazon.com/dp/B071WS1TYG>, Earliest review date of Sep. 8, 2017, downloaded on Aug. 9, 2018.

“Spigen Tough Armor Galaxy S8 Active Case with Kickstand and Extreme Heavy Duty Protection and Air Cushion Technology for Galaxy S8 Active (2017)—Gunmetal”, <http://www.amazon.com/dp/B0746PT25T>, Earliest review date of Sep. 15, 2017, downloaded on Aug. 9, 2018.

“Spigen Tough Armor Designed for Apple iPhone X Case (2018) / Designed for Apple iPhone X Case (2017)—Matte Black”, <http://www.amazon.com/dp/B074CMT7HV>, Earliest review date of Sep. 27, 2017, downloaded on Jan. 15, 2019.

“Spigen Tough Armor Designed for Apple iPad Pro 10.5 Case (2017)—Black”, <http://www.amazon.com/dp/B0751GFB8X>, Earliest review date of Oct. 11, 2017, downloaded on Jan. 15, 2019.

“Spigen Tough Armor Designed for Apple iPad 9.7 Case iPad Case (2017/2018)—Black”, <http://www.amazon.com/dp/B072F7DGMJ>, Earliest review date of Jan. 23, 2017, downloaded on Jan. 15, 2019.

“Spigen Tough Armor Google Pixel 2 Case with Kickstand and Extreme Heavy Duty Protection and Air Cushion Technology for Google Pixel 2 (2017)—Gunmetal”, <http://www.amazon.com/dp/B0747523HC>, Earliest review date of Oct. 28, 2017, downloaded on Aug. 9, 2018.

“Spigen Tough Armor Google Pixel 2 XL Case with Kickstand and Extreme Heavy Duty Protection and Air Cushion Technology for Google Pixel 2 XL (2017)—Black”, <http://www.amazon.com/dp/B07477LL8Q>, Earliest review date of Oct. 29, 2017, downloaded on Aug. 9, 2018.

“Spigen Tough Armor Moto Z2 Force Case with Kickstand and Extreme Heavy Duty Protection and Air Cushion Technology for Moto Z2 Force (2017)—Gunmetal”, <http://www.amazon.com/dp/B074PB5HQ1>, Earliest review date of Nov. 21, 2017, downloaded on Aug. 9, 2018.

“Spigen Tough Armor Tech Designed for Apple iPad 9.7 Case iPad Case (2017/2018)—Black”, <http://www.amazon.com/dp/B078FGC17H>, Earliest review date of Feb. 18, 2018, downloaded on Jan. 15, 2019.

“Spigen Tough Armor Galaxy S9 Plus Case with Reinforced Kickstand and Heavy Duty Protection and Air Cushion Technology for Samsung Galaxy S9 Plus (2018)—Lilac Purple”, <http://www.amazon.com/dp/B078BBPY98>, Earliest review date of Mar. 1, 2018, downloaded on Jan. 15, 2019.

“Spigen Tough Armor Galaxy S9 Case with Reinforced Kickstand and Heavy Duty Protection and Air Cushion Technology for Samsung Galaxy S9 (2018)—Graphite Gray”, <http://www.amazon.com/dp/B078B3K513>, Earliest review date of Mar. 10, 2018, downloaded on Jan. 16, 2019.

“Spigen Tough Armor Galaxy S9 Case with Reinforced Kickstand and Heavy Duty Protection and Air Cushion Technology for Samsung Galaxy S9 (2018)—Graphite Gray”, <http://www.amazon.com/dp/B078B3K513>, Earliest review date of Mar. 10, 2018, downloaded on Aug. 9, 2018.

“Spigen Tough Armor LG G7 Case/LG G7 ThinQ Case with Reinforced Kickstand and Heavy Duty Protection and Air cushion Technology for LG G7 ThinQ (2018)—Gunmetal”, <https://www.amazon.com/Spigen-Reinforced-Kickstand-Protection-Technology/dp/B078MVT4YD>, Earliest review date of Jun. 1, 2018, downloaded on Aug. 9, 2018.

* cited by examiner

Primary Examiner — Carla J Wright

(74) *Attorney, Agent, or Firm* — Heedong Chae; Lucem, PC

(57) **CLAIM**

The ornamental design for a case for electronic communications device, as shown and described.

DESCRIPTION

FIG. 1 is a front perspective view of the case for electronic communications device showing my new design;

FIG. 2 is a rear perspective view thereof;

FIG. 3 is a front elevational view thereof;

FIG. 4 is a rear elevational view thereof;

FIG. 5 is a left side elevational view thereof;

FIG. 6 is a right side elevational view thereof;

FIG. 7 is a top plan view thereof;

FIG. 8 is a bottom plan view thereof;

FIG. 9 is a rear perspective view of the case in a folded position in an environment of use;

FIG. 10 is a front perspective view of the impact foam component of the left half of the case;

FIG. 11 is a rear perspective view of the impact foam component of the left half of the case;

FIG. 12 is a front perspective view of the inner shell component of the left half of the case;

FIG. 13 is a rear perspective view of the inner shell component of the left half of the case;

FIG. 14 is a front perspective view of the outer frame component of the left half of the case;

FIG. 15 is a rear perspective view of the outer frame component of the right half of the case;

FIG. 16 is a front perspective view of the impact foam component of the right half of the case;

FIG. 17 is a rear perspective view of the impact foam component of the right half of the case;

FIG. 18 is a front perspective view of the inner shell component of the right half of the case;

FIG. 19 is a rear perspective view of the inner shell component of the right half of the case;

FIG. 20 is a front perspective view of the outer frame component of the right half of the case;

FIG. 21 is a rear perspective view of the outer frame component of the right half of the case;

FIG. 22 is another rear elevational view of the case showing the left half and right half of the case being extended laterally from each other;

FIG. 23 is an exploded front perspective view showing the components of the case separated for clarity of disclosure;

FIG. 24 is an exploded rear perspective view showing the components of the case separated for clarity of disclosure;

FIG. 25 is an enlarged view of the encircled region of FIG. 9;

FIG. 26 is an enlarged view of the encircled region of FIGS. 13 and 24; and,

FIG. 27 is an enlarged view of the encircled region of FIG. 1.

For clarity of disclosure, the components of the case are shown in isolation in FIGS. 10-21 and separated in FIGS. 23-24. Although the case for electronic communications device, in which the claimed design is embodied, has two impact foam components, two inner shell components, and two outer frame components, the claim is directed to the overall ornamental appearance of the case in its entirety and does not extend to the ornamental appearance of each of the individual components in isolation.

The dot-dash broken line circles in FIGS. 1, 9, 13, and 24-27 delineate portions of the case, including claimed subject matter, that are shown on an enlarged scale in FIGS. 25-27. The dash-dash broken lines throughout the drawing figures depict environmental subject matter and portions of the case that form no part of the claimed design.

1 Claim, 27 Drawing Sheets

FIG. 1

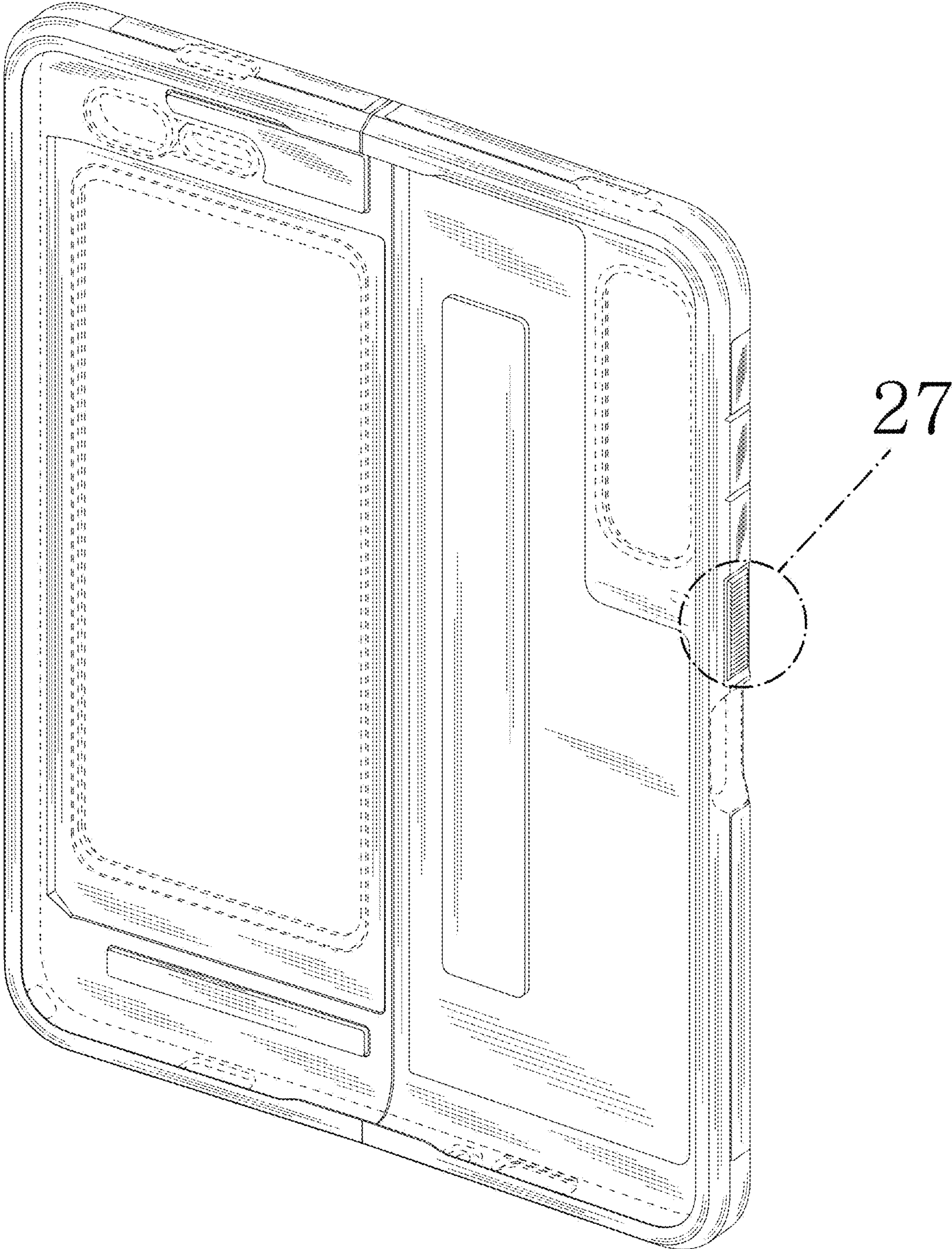

FIG. 2

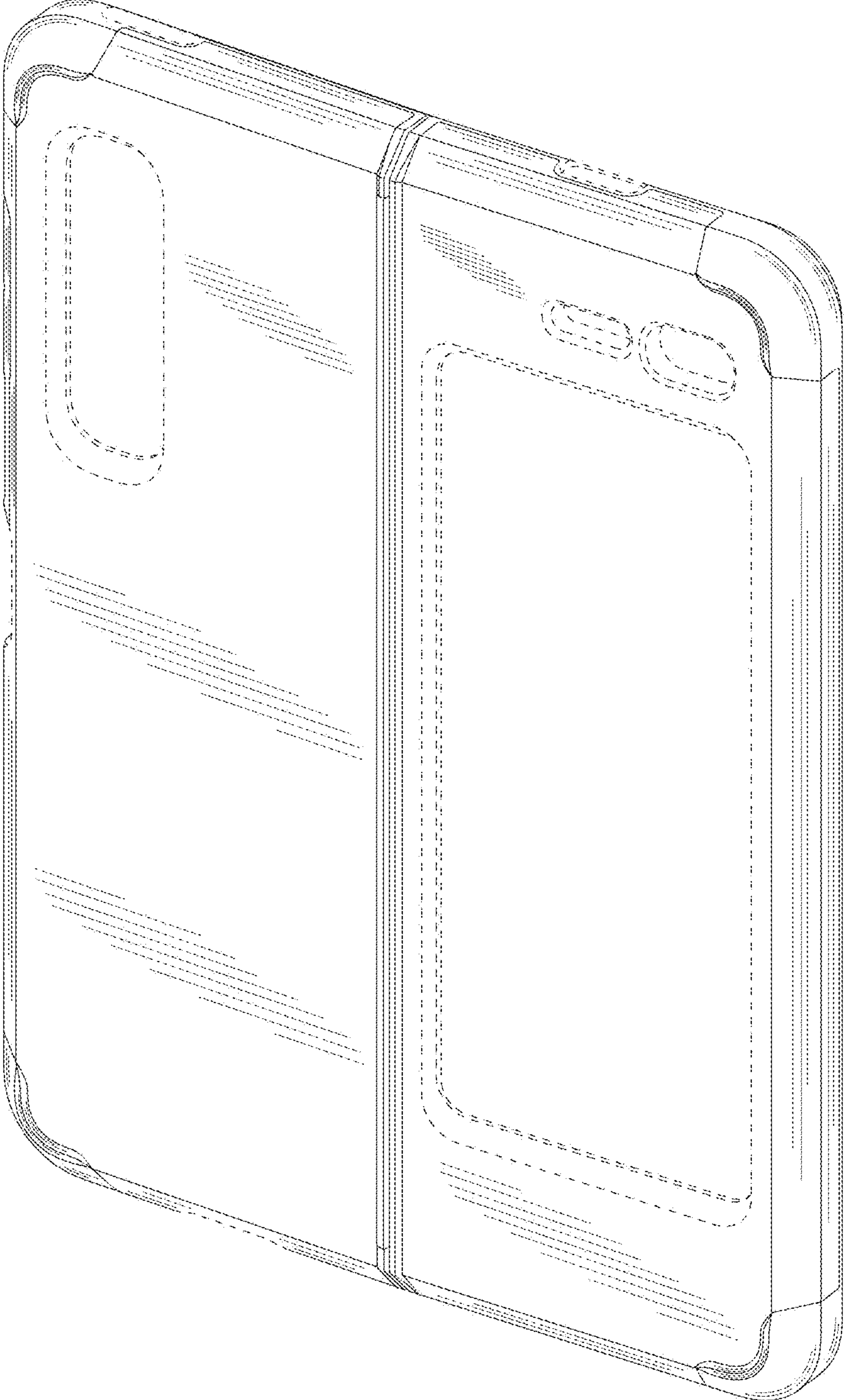

FIG. 3

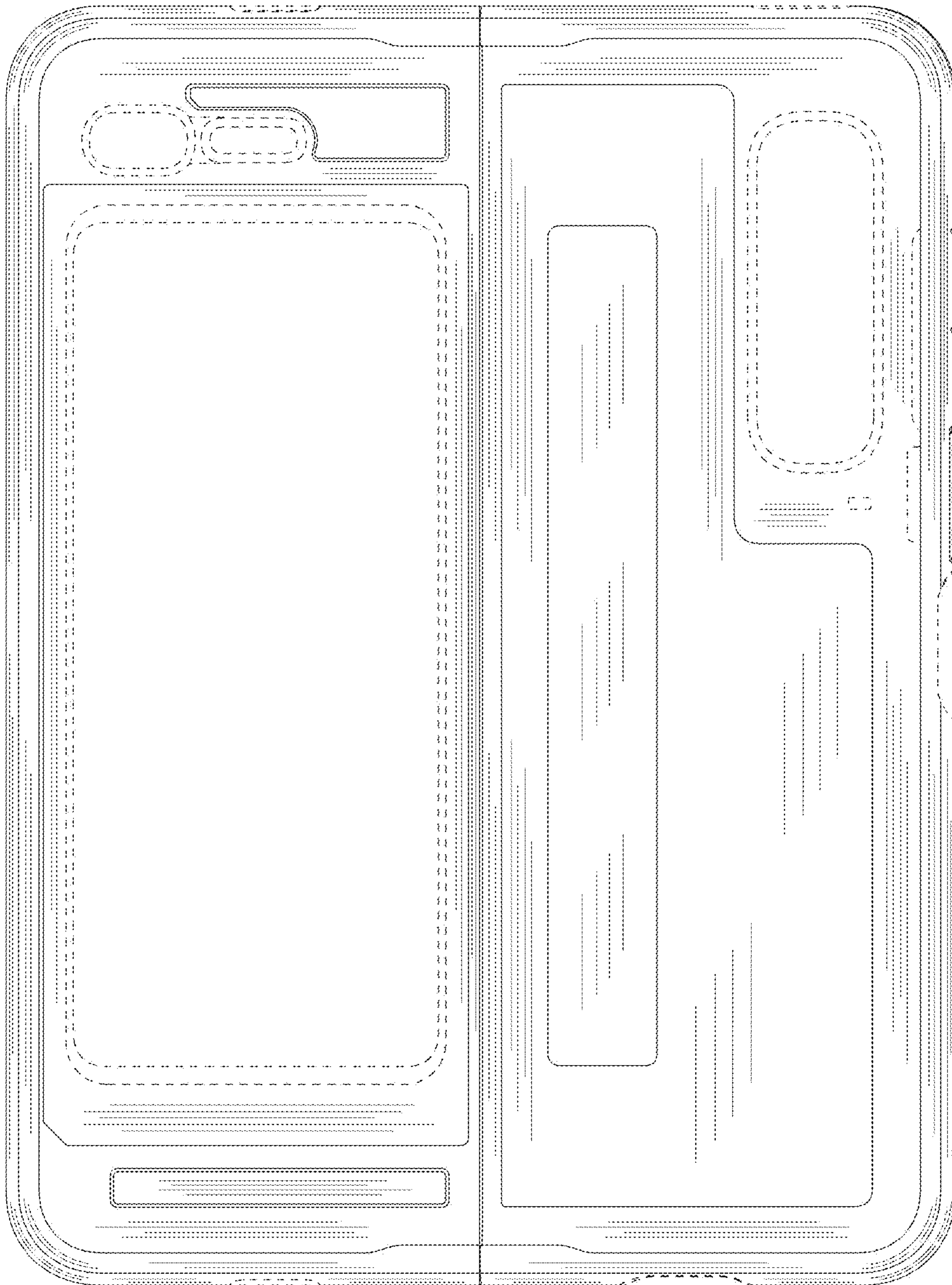

FIG. 4

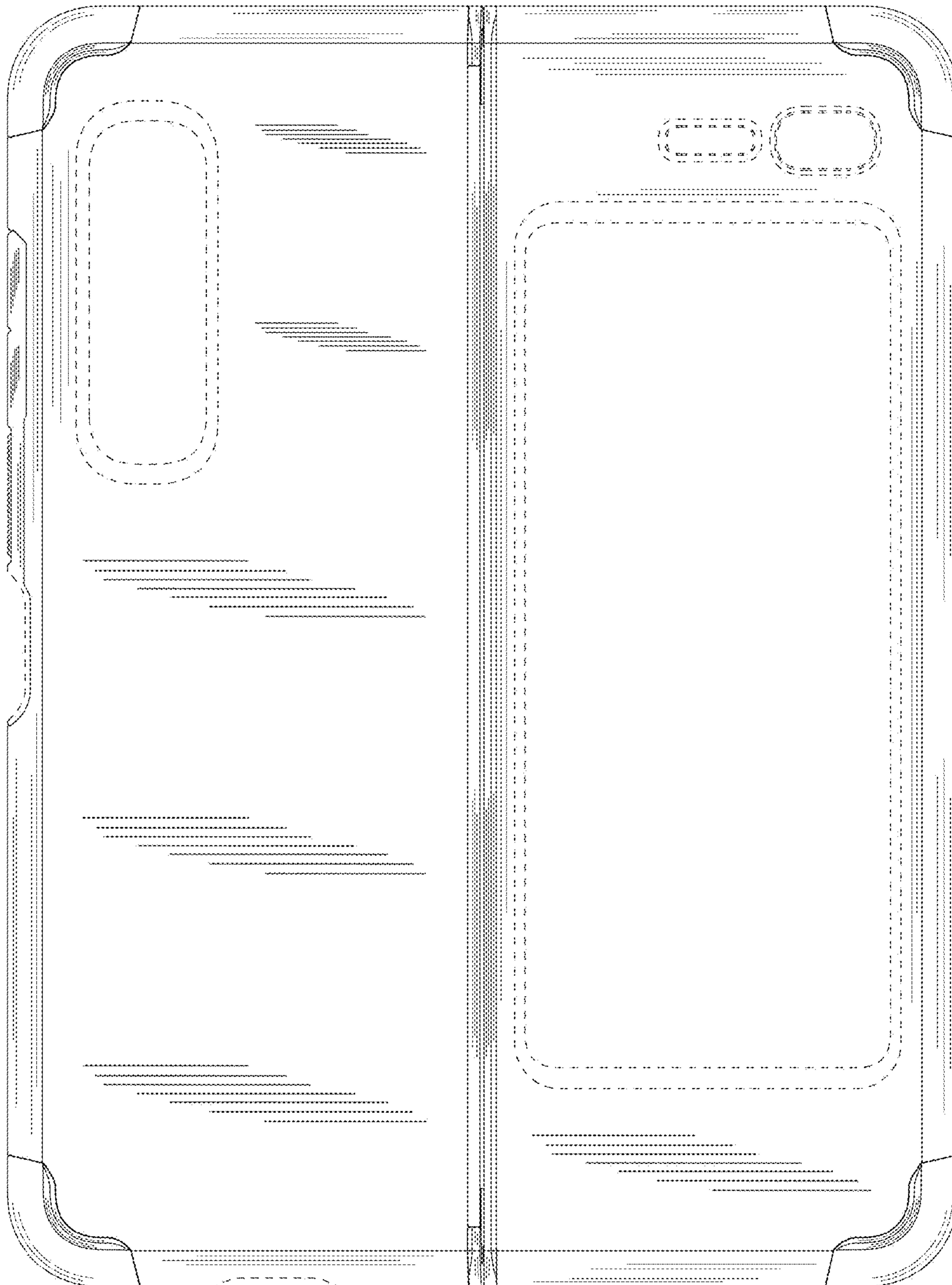

FIG. 5

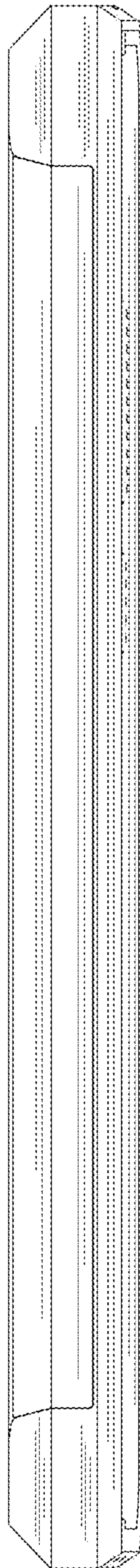

FIG. 6

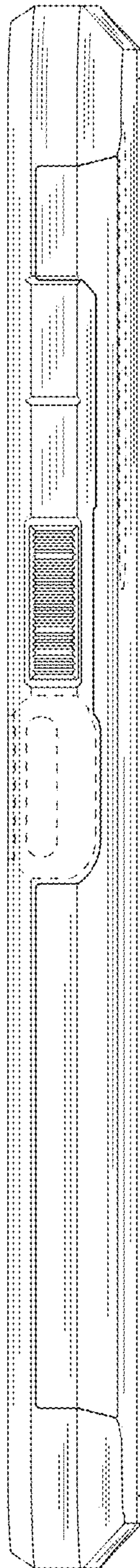

FIG. 7

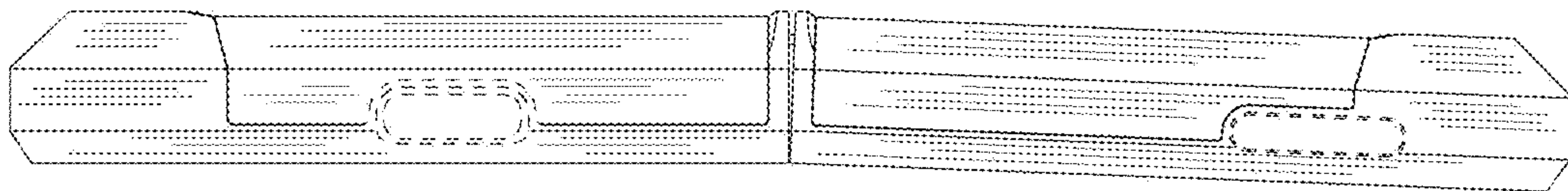

FIG. 8

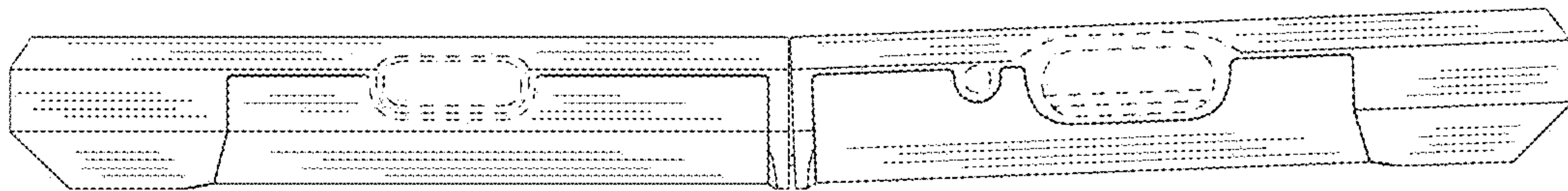

FIG. 9

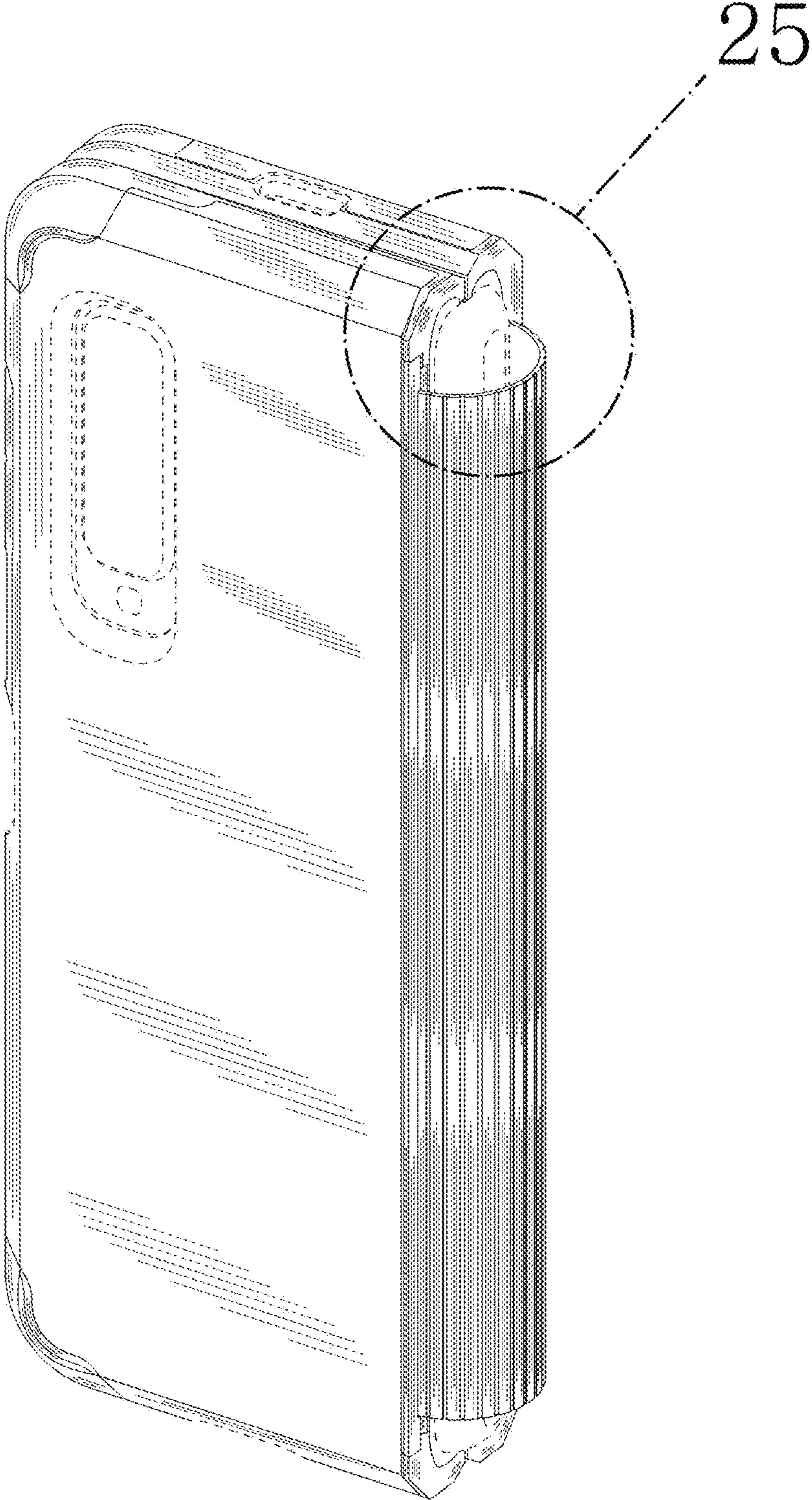

FIG. 10

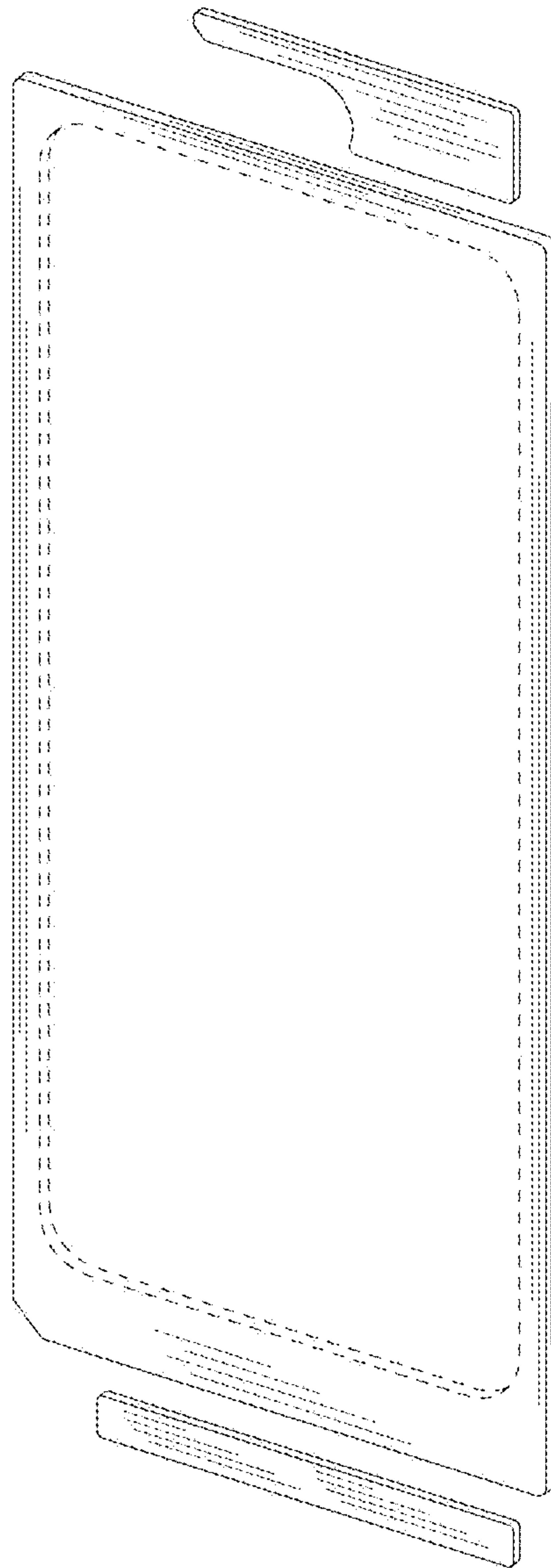
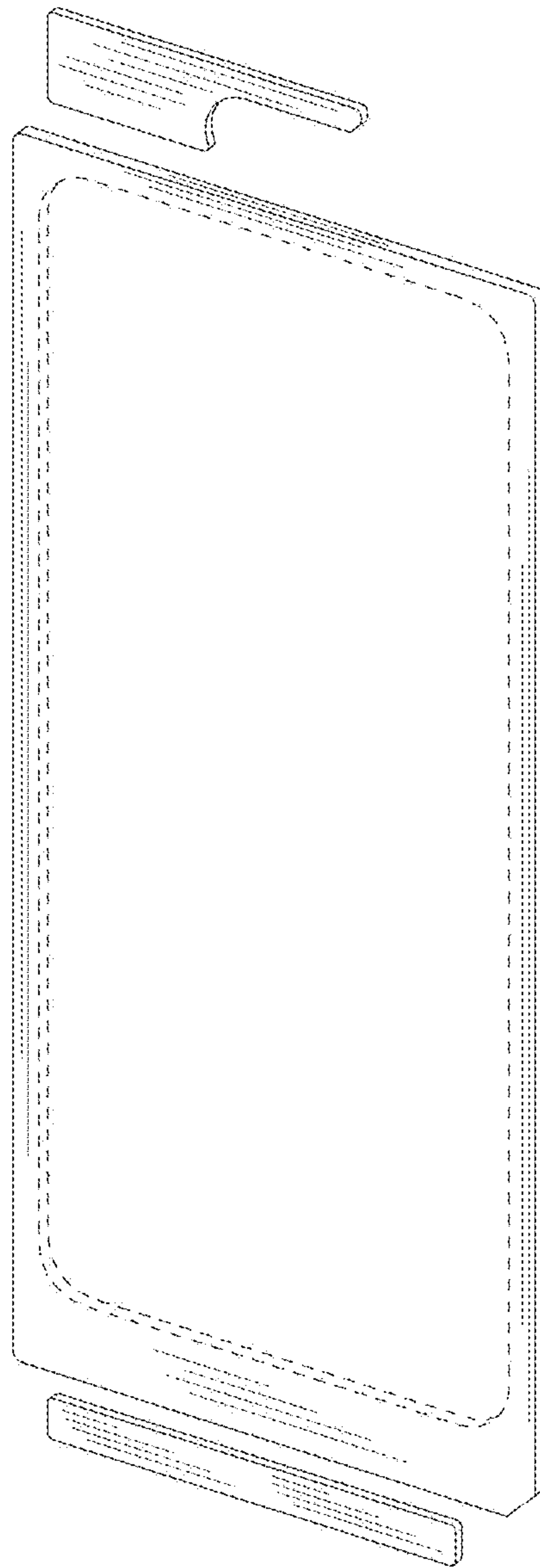

FIG. 11



[REPLACEMENT SHEET]

FIG. 12

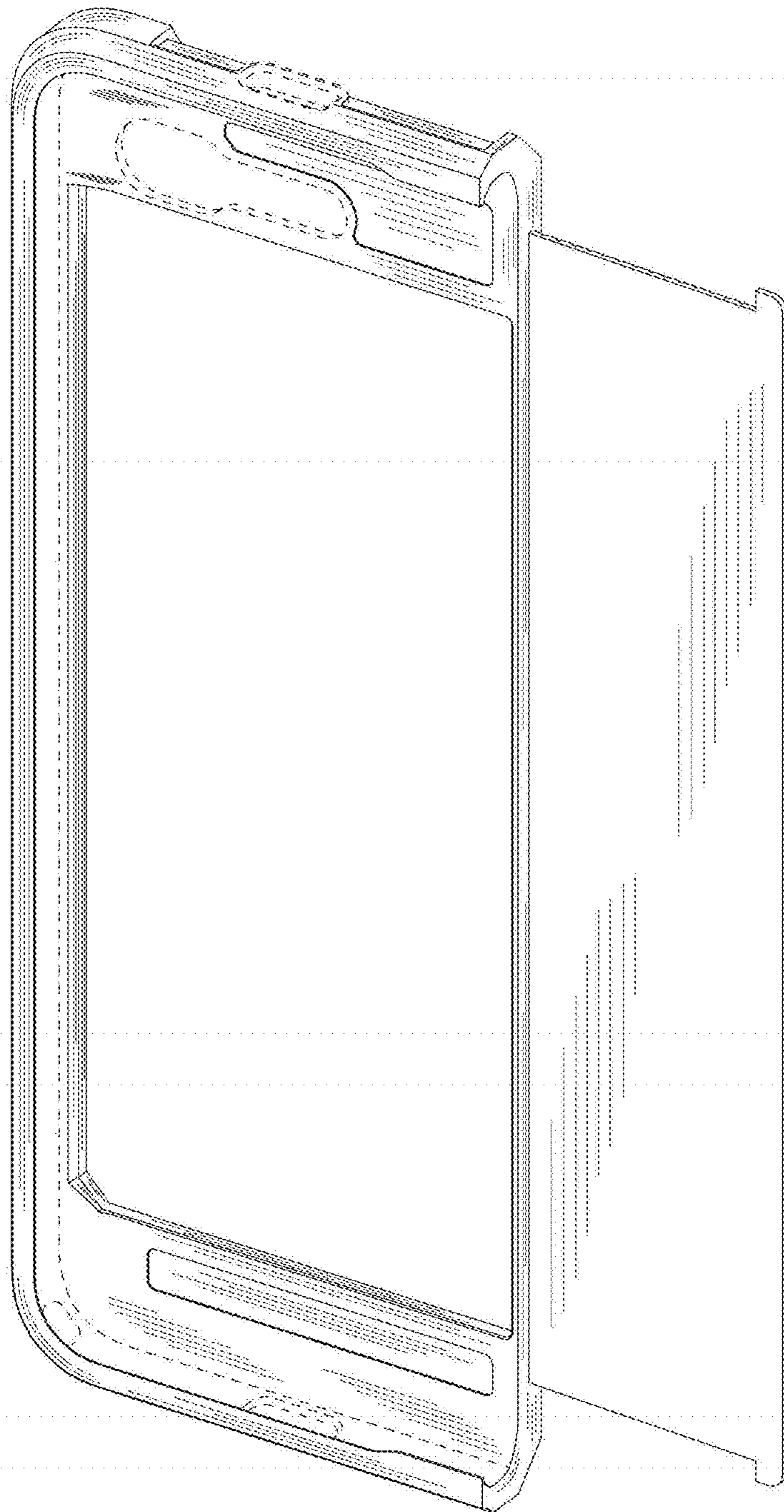

FIG. 13

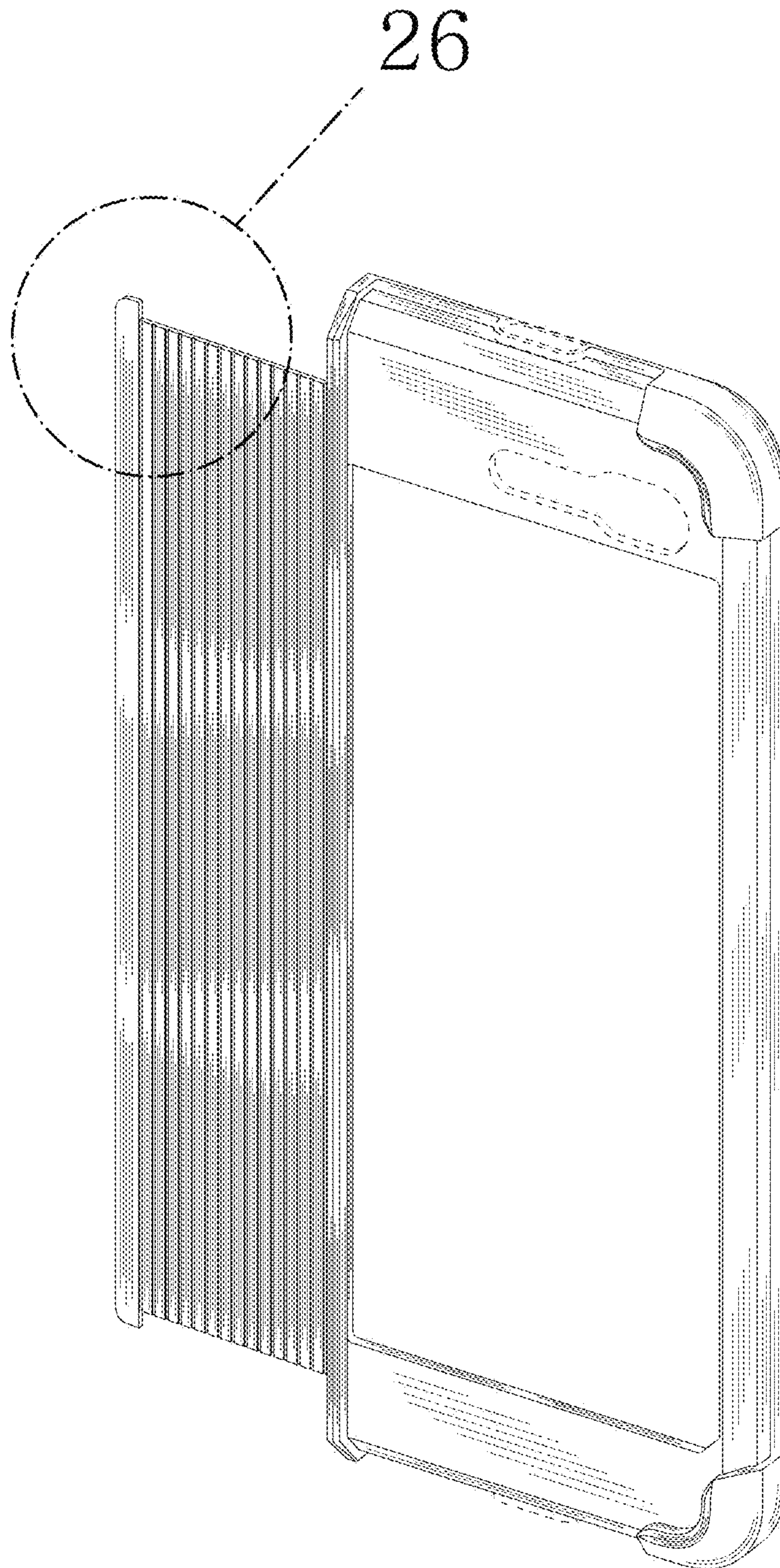
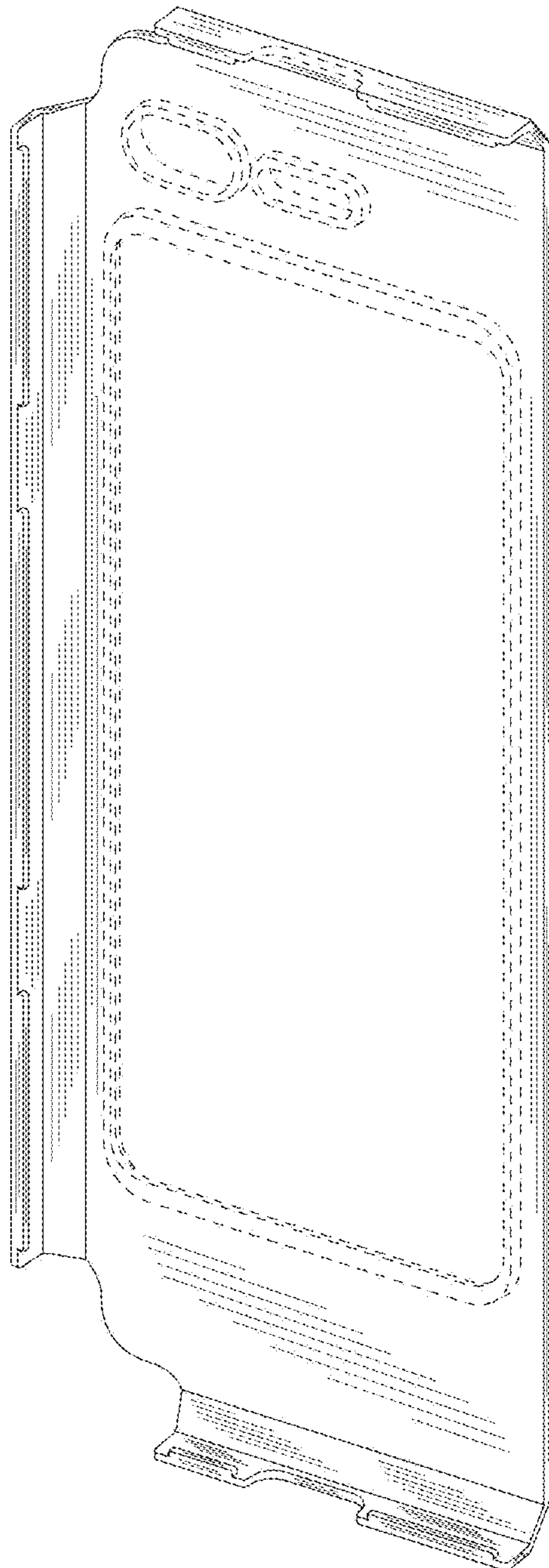

FIG. 14



[REPLACEMENT SHEET]

FIG. 15

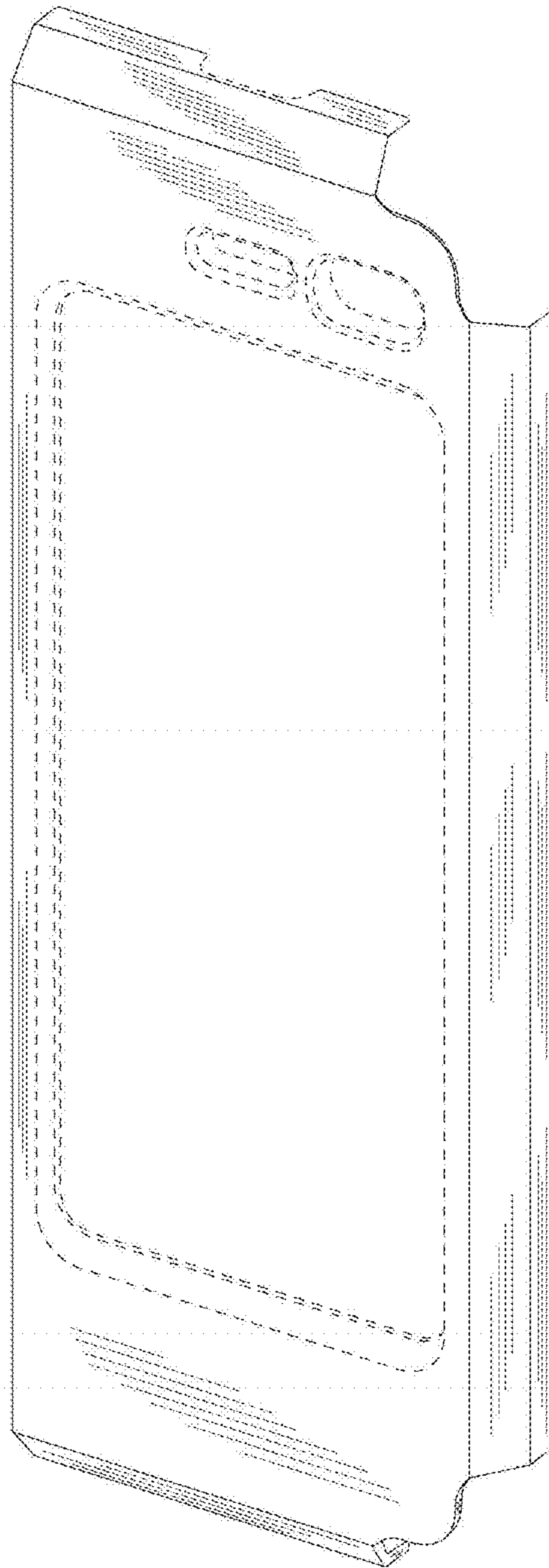

FIG. 16

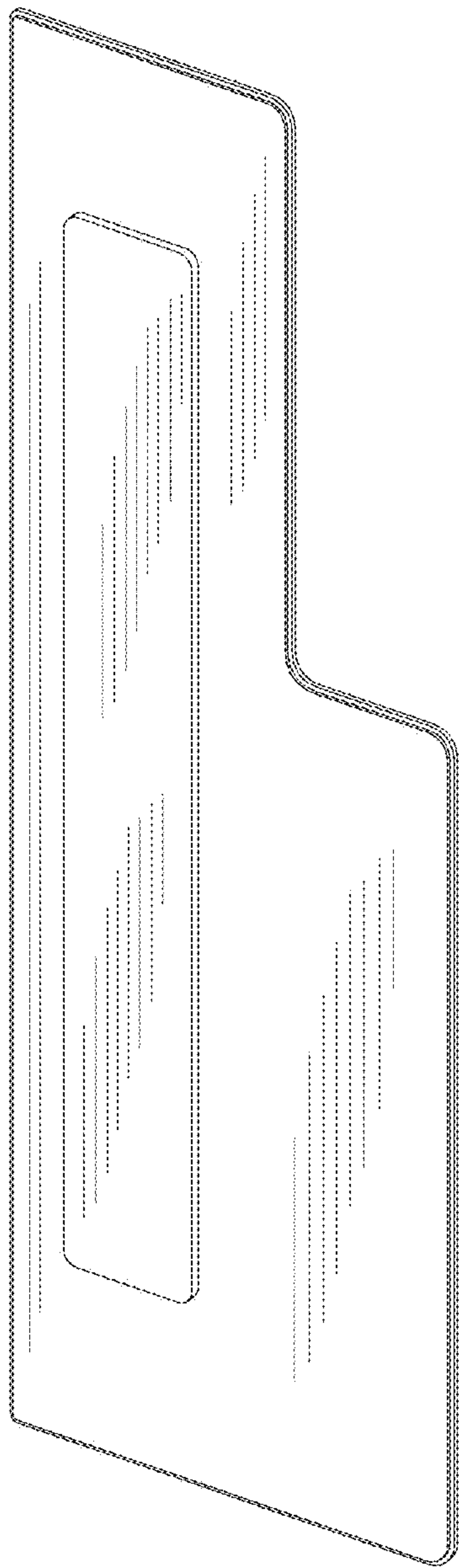

FIG. 17

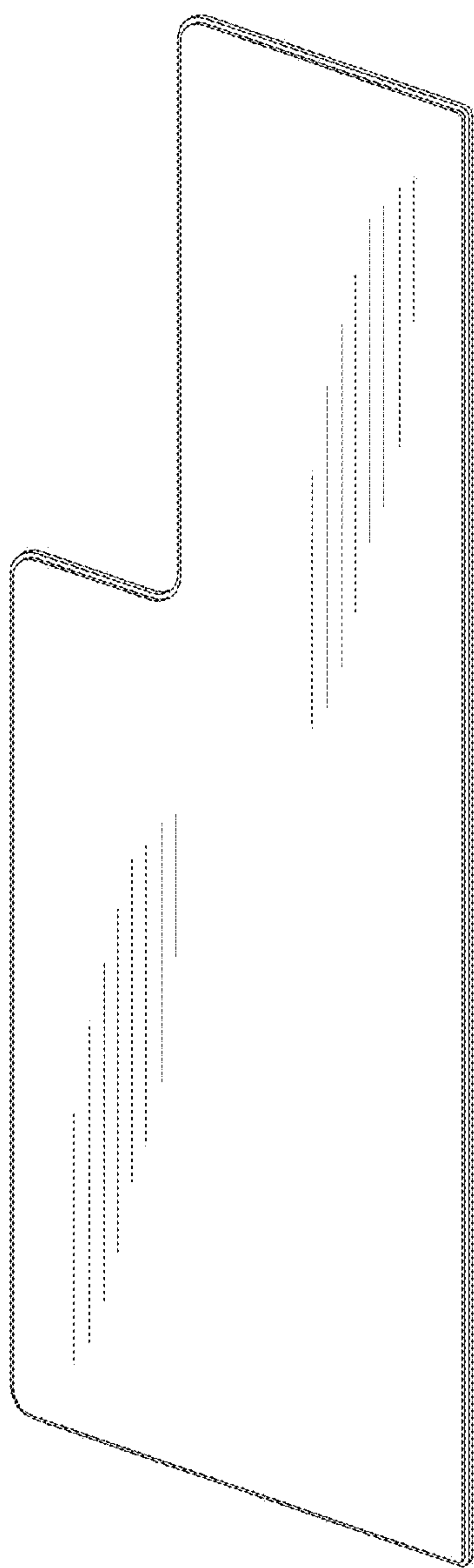

FIG. 18

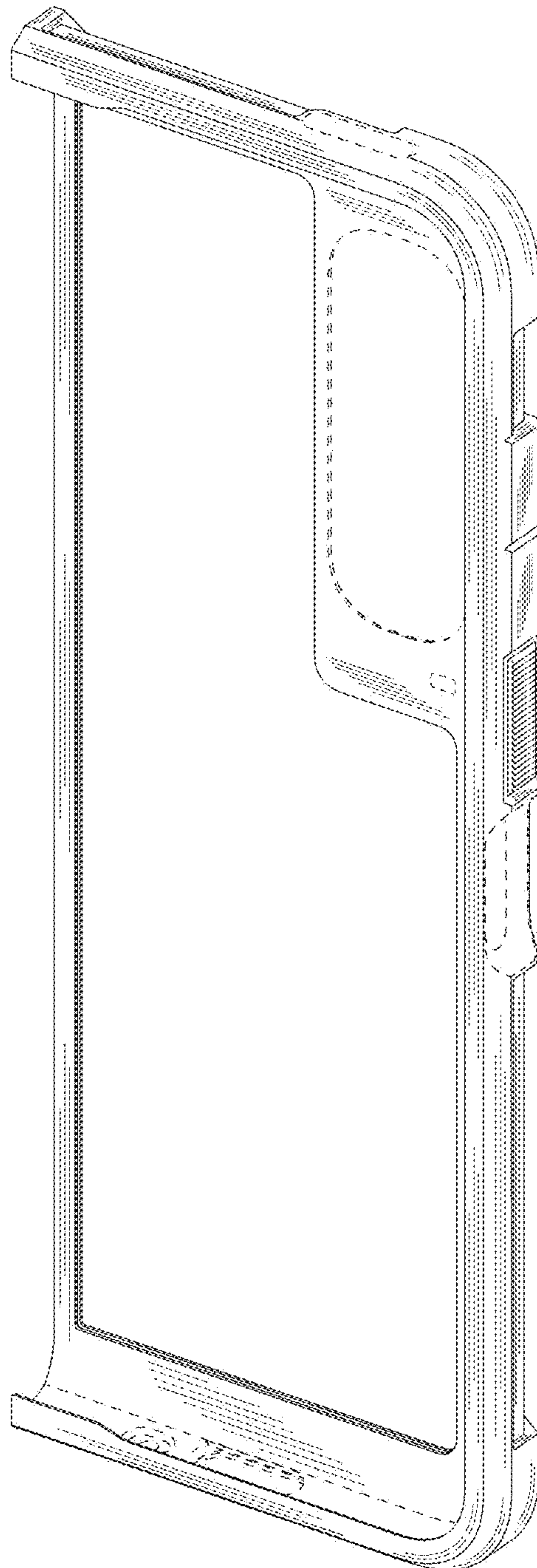

FIG. 19

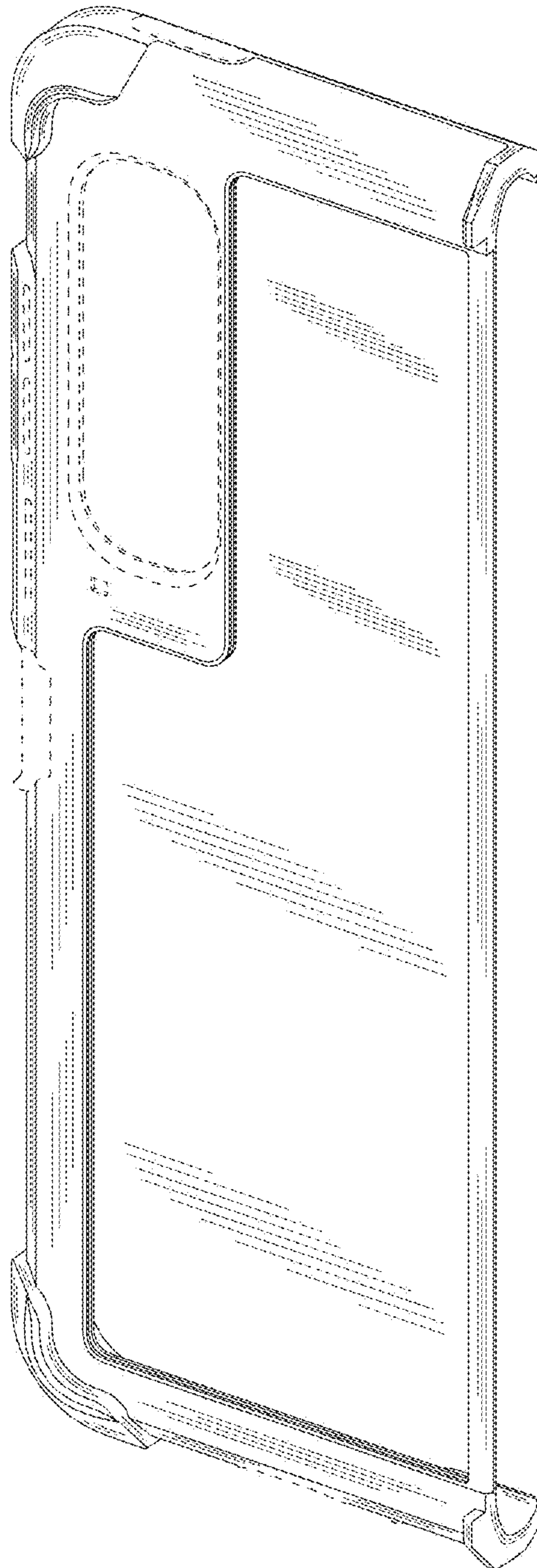

FIG. 20

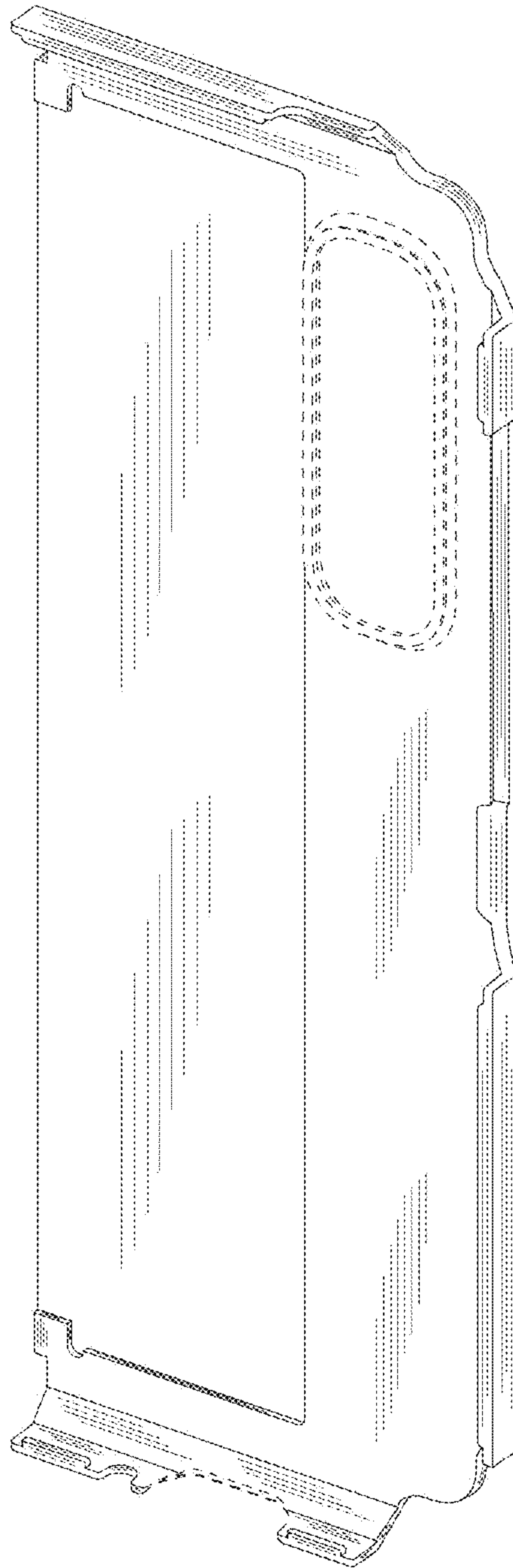

FIG. 21

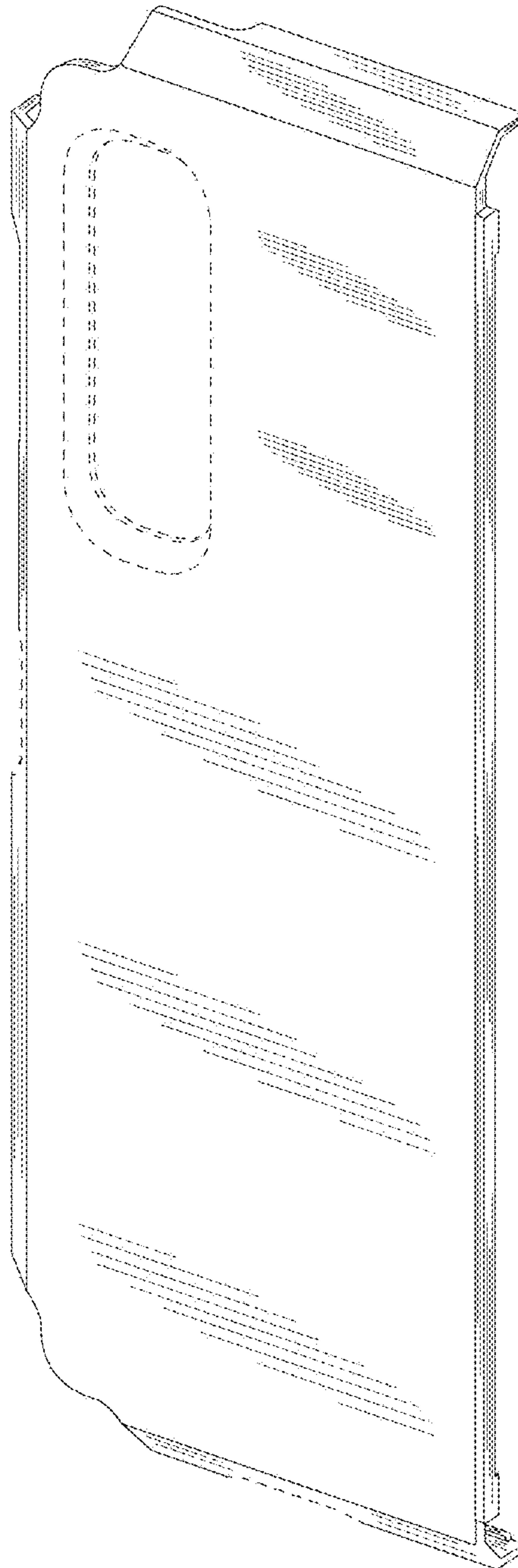

FIG. 22

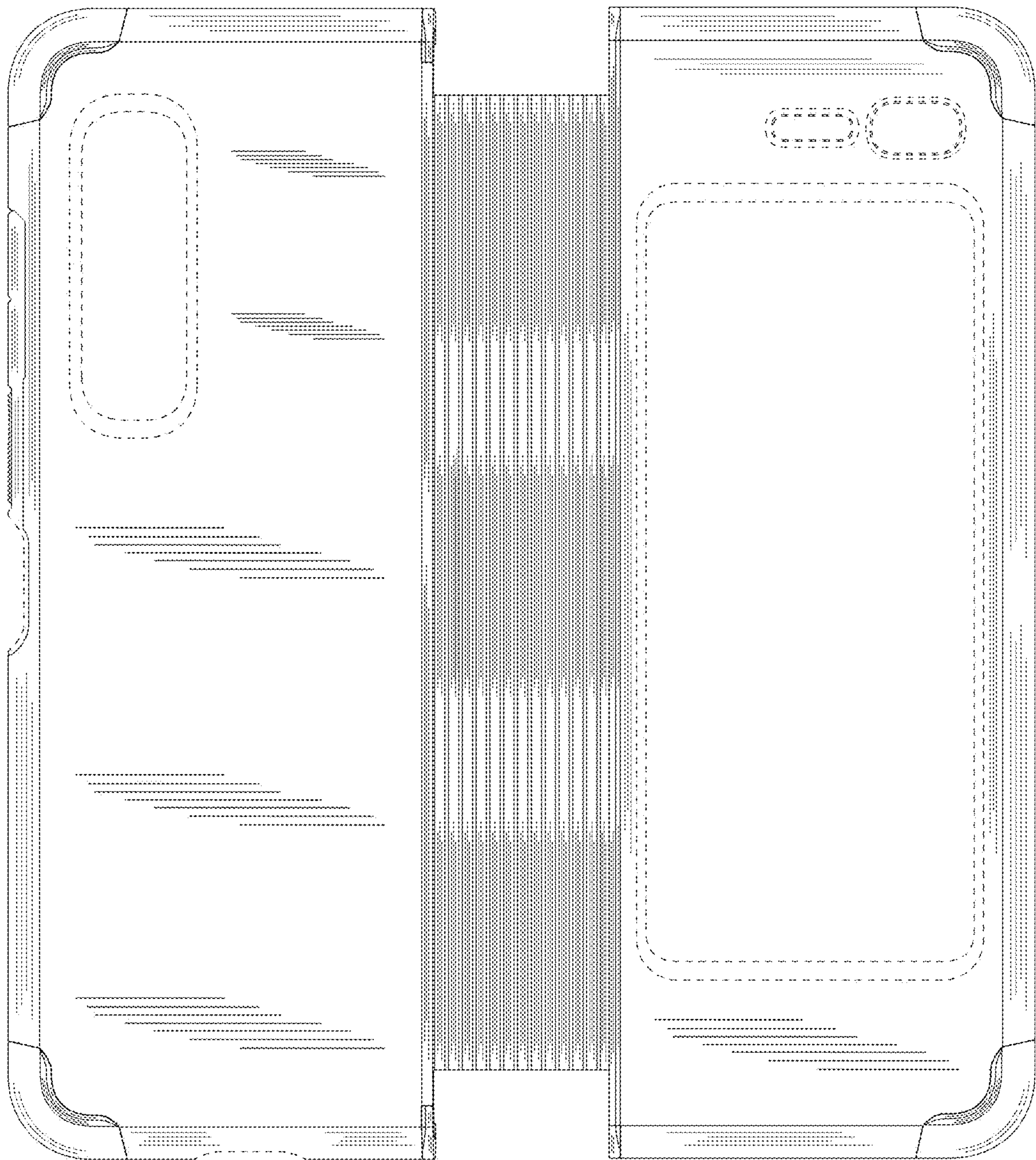

FIG. 23

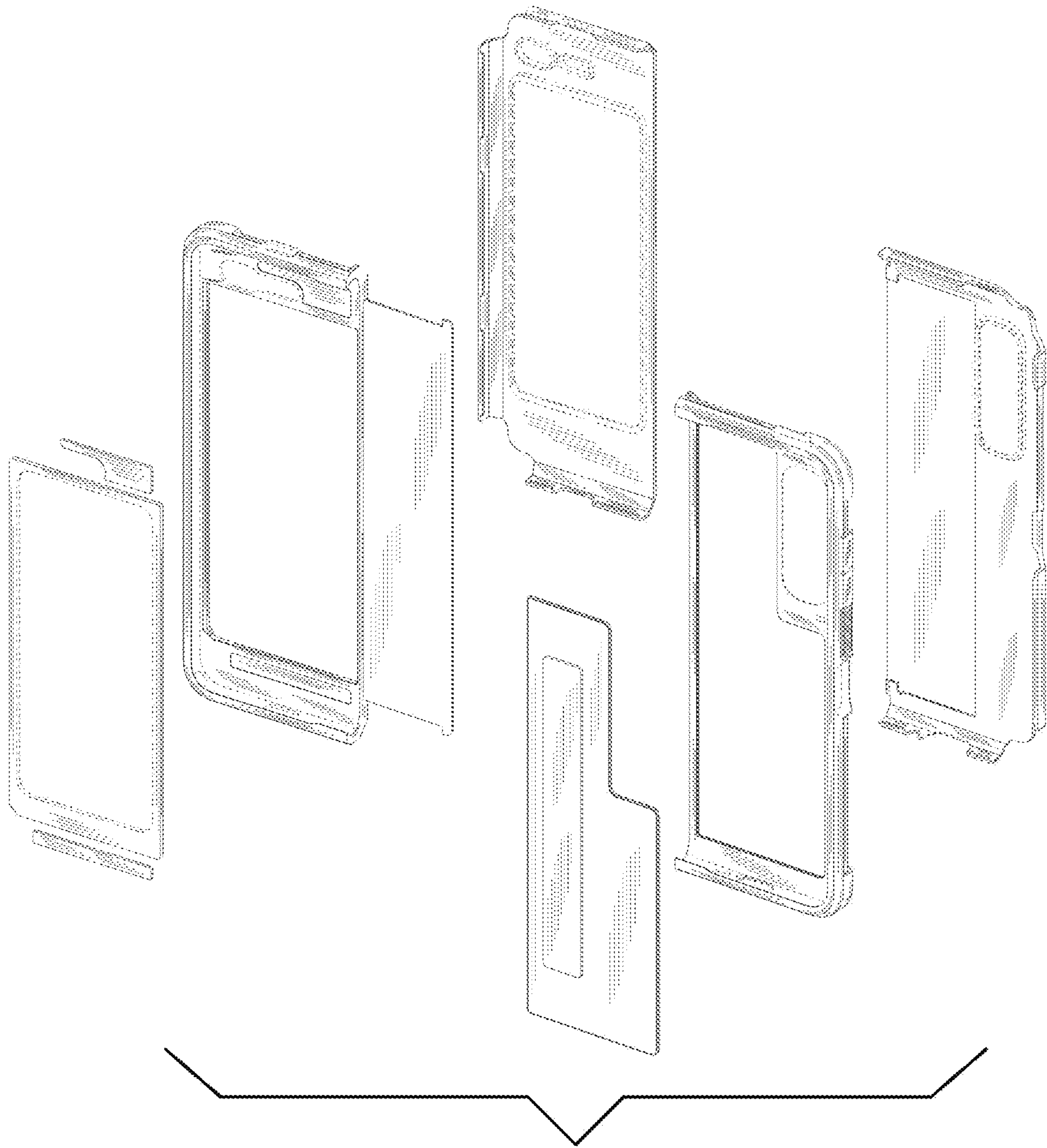

FIG. 24

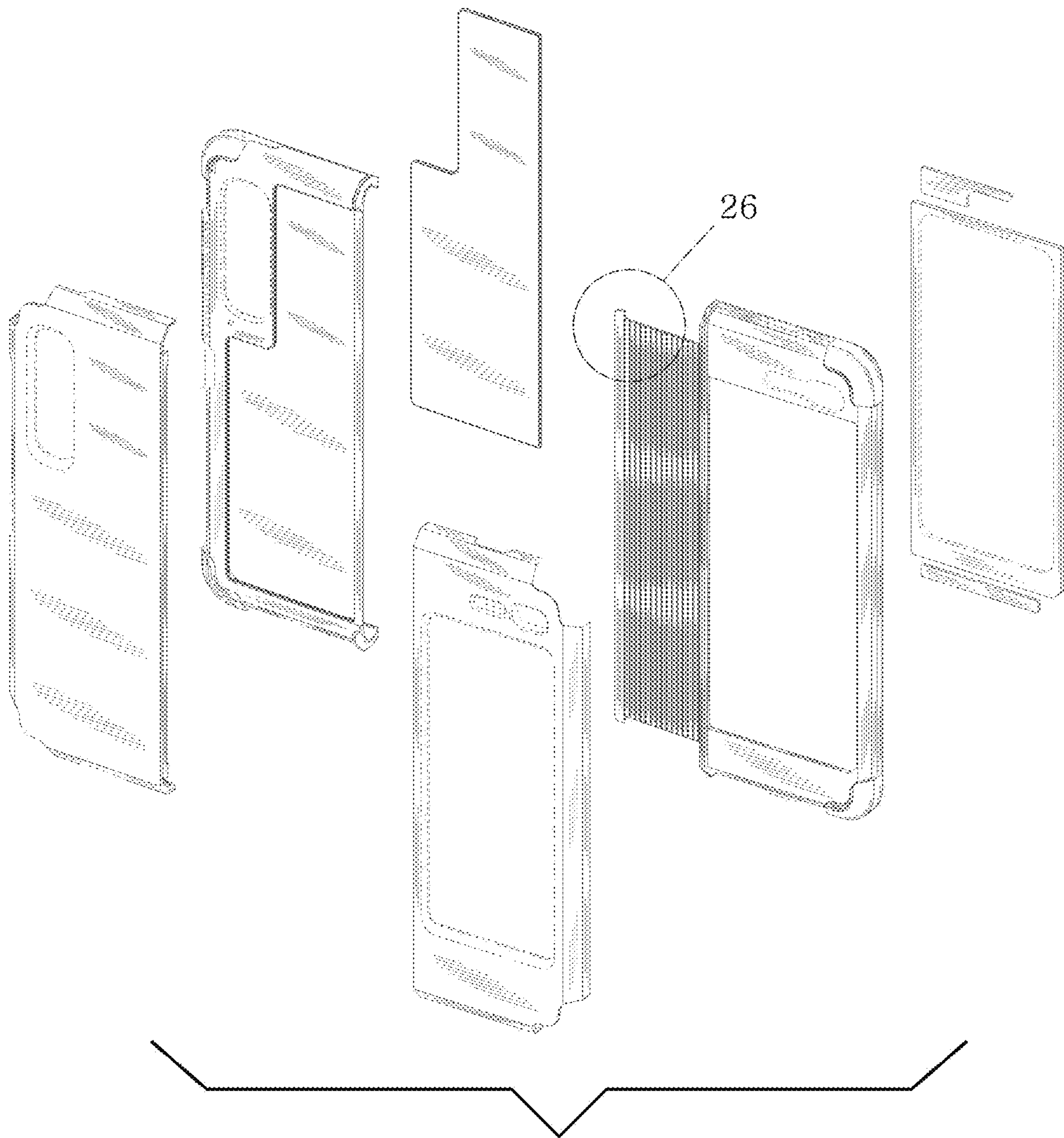

FIG. 25

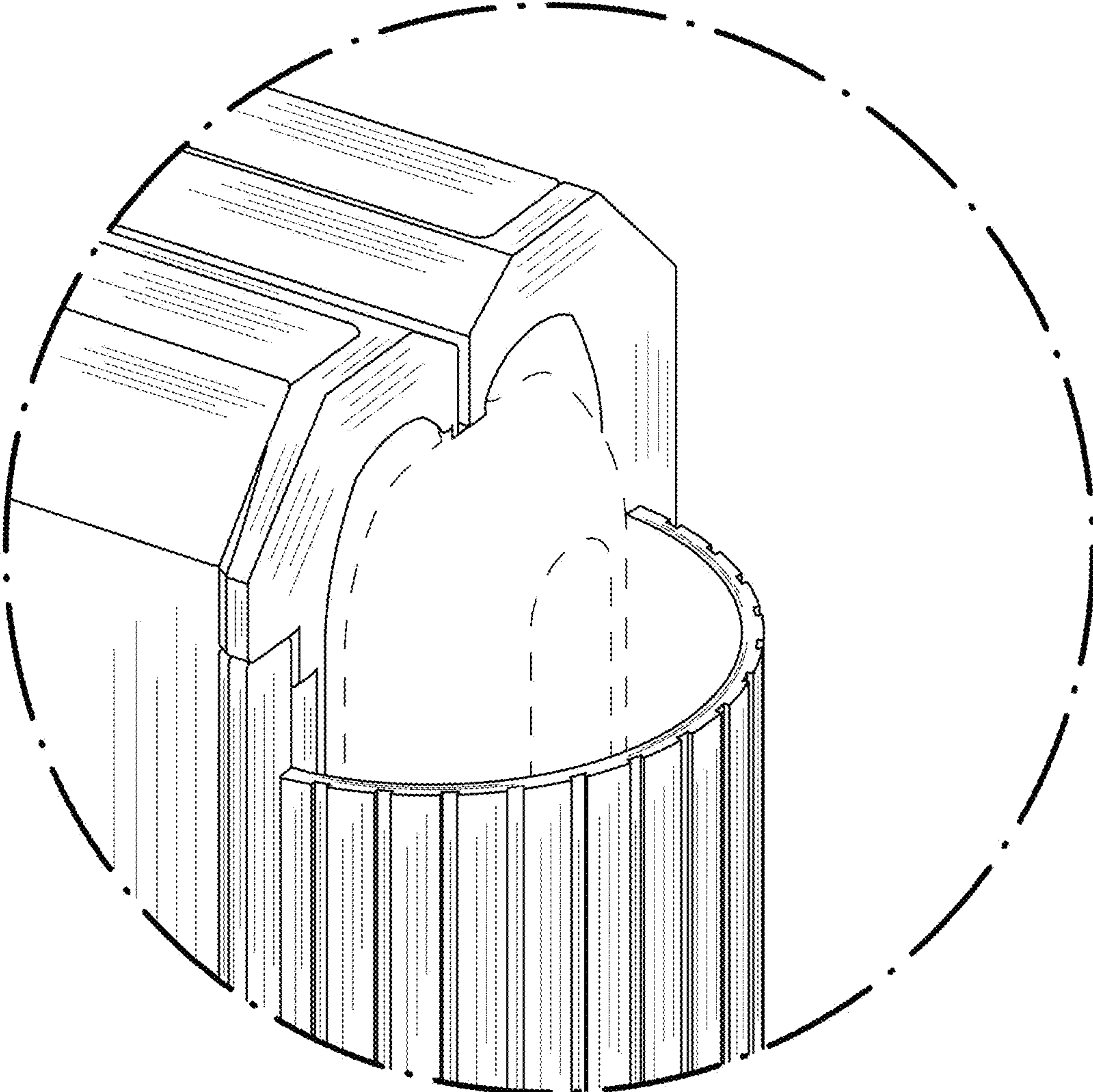

FIG. 26

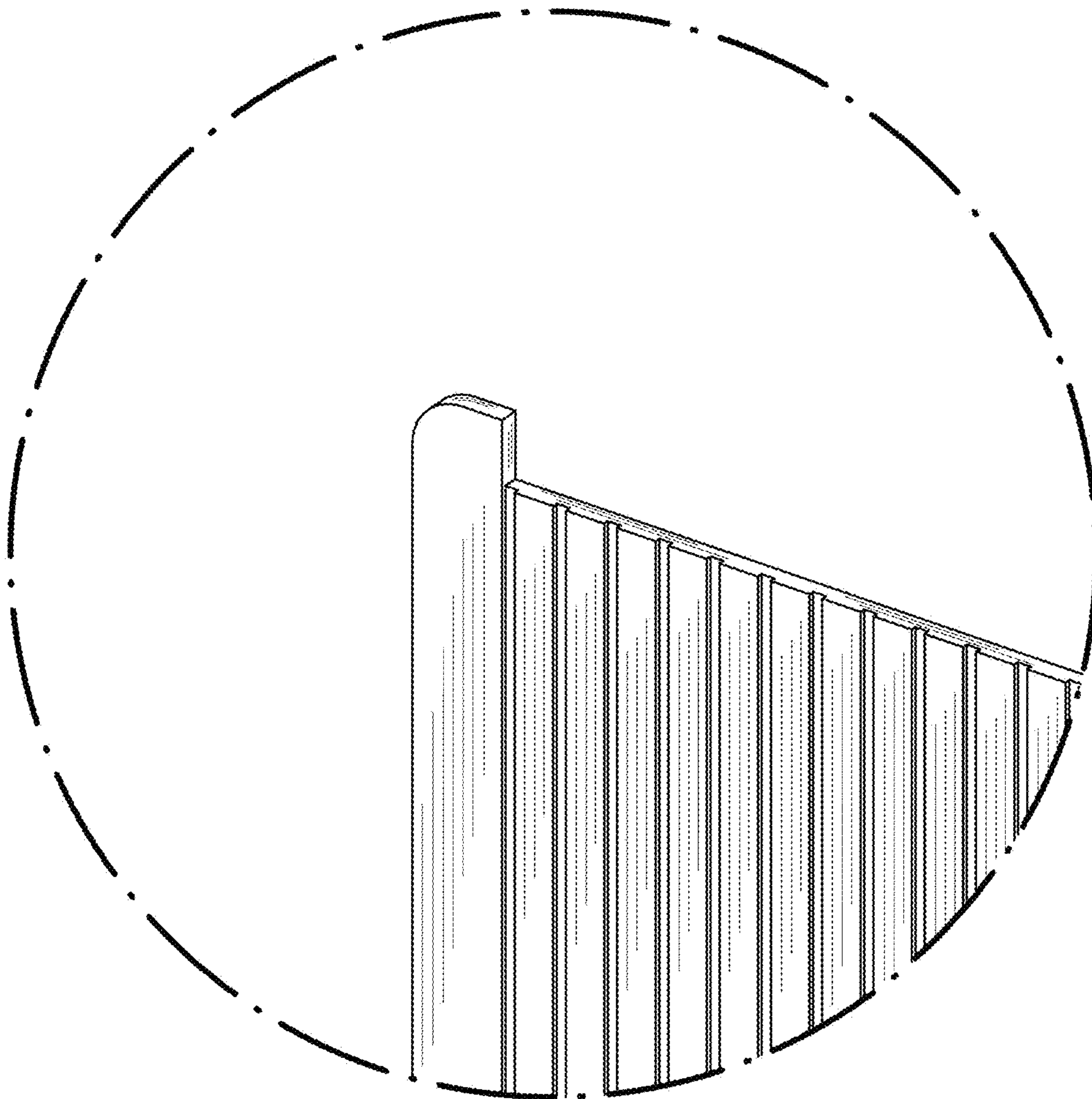

FIG. 27

