



US00D905639S

(12) **United States Design Patent** (10) **Patent No.:** **US D905,639 S**
Azuma (45) **Date of Patent:** **** Dec. 22, 2020**

(54) **ELECTRIC POWER UNIT**
(71) Applicant: **HONDA MOTOR CO., LTD.**, Tokyo (JP)
(72) Inventor: **Koichi Azuma**, Wako (JP)
(73) Assignee: **HONDA MOTOR CO., LTD.**, Tokyo (JP)
(**) Term: **15 Years**
(21) Appl. No.: **29/701,564**
(22) Filed: **Aug. 13, 2019**
(30) **Foreign Application Priority Data**
Feb. 15, 2019 (JP) 2019-003048
(51) **LOC (12) Cl.** **13-01**
(52) **U.S. Cl.**
USPC **D13/116**
(58) **Field of Classification Search**
USPC D13/103, 107, 108, 110, 112, 113, 114,
D13/116, 117, 118, 119, 122, 184, 199;
D15/1, 5
CPC H02K 11/00; H02K 15/16; H02K 11/0094
See application file for complete search history.

D712,834 S * 9/2014 Munro D13/116
D768,078 S * 10/2016 Wu D13/112
D790,466 S * 6/2017 Lin D13/112
D826,149 S * 8/2018 Cooper D13/103
D834,517 S * 11/2018 Fritz D13/116
D858,441 S * 9/2019 Chen D13/110
2017/0104243 A1 * 4/2017 Velderman H01M 10/425

OTHER PUBLICATIONS

“Honda Power Unit”. Found online Sep. 14, 2020 at global.honda.
Reference dated Mar. 29, 2019. Retrieved from <https://global.honda/newsroom/news/2019/p190329eng.html>. (Year: 2019).*

(Continued)

Primary Examiner — Kendra Leslie Hamilton
Assistant Examiner — Amanda Christensen
(74) *Attorney, Agent, or Firm* — Westerman, Hattori,
Daniels & Adrian, LLP

(57) **CLAIM**

The ornamental design for, an electric power unit, as shown and described.

DESCRIPTION

FIG. 1 is a front, right perspective view of an electric power unit, showing my new design;
FIG. 2 is a front, left perspective view thereof;
FIG. 3 is a rear, right perspective view thereof;
FIG. 4 is a rear, left perspective view thereof;
FIG. 5 is a front elevation view thereof;
FIG. 6 is a rear elevation view thereof;
FIG. 7 is a right side elevation view thereof;
FIG. 8 is a left side elevation view thereof;
FIG. 9 is a top plan view thereof; and,
FIG. 10 is a bottom plan view thereof.
The broken lines depict portions of the electric power unit that form no part of the claimed design.

1 Claim, 10 Drawing Sheets

(56) **References Cited**
U.S. PATENT DOCUMENTS
6,331,740 B1 * 12/2001 Morohoshi F02B 63/04
123/41.56
D523,807 S * 6/2006 Murayama D13/103
7,089,889 B2 * 8/2006 Johnson F02B 63/04
123/198 E
7,492,050 B2 * 2/2009 Brandenburg H02K 9/06
290/1 B
D593,032 S * 5/2009 Wang D13/116
D711,825 S * 8/2014 Wilson D13/112

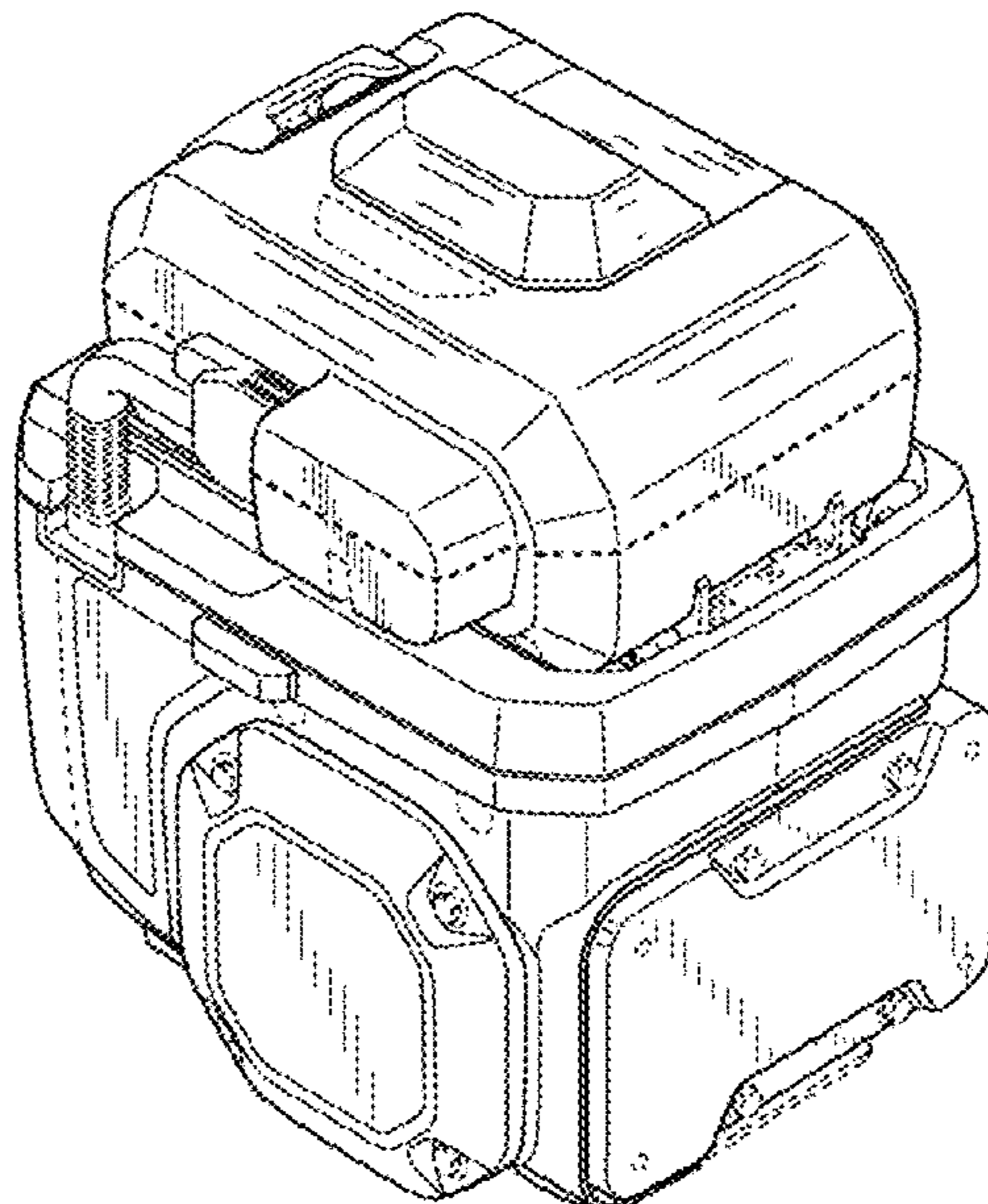

(56)

References Cited

OTHER PUBLICATIONS

“Honda eGX”. Found online Sep. 14, 2020 at facebook.com. Reference dated Apr. 10, 2019. Retrieved from <https://www.facebook.com/demal/photos/a.588805704565570/2088533404592785/?type=3&theater>. (Year: 2019).*

“Champion Inverter”. Found online Sep. 17, 2020 at amazon.com. Reference dated Aug. 24, 2017. Retrieved from https://www.amazon.com/Champion-4000-Watt-Ready-Inverter-Technology/dp/B01M3R711N/ref=asc_df_B01M3R711N/?th=1. (Year: 2017).*

* cited by examiner

FIG. 1

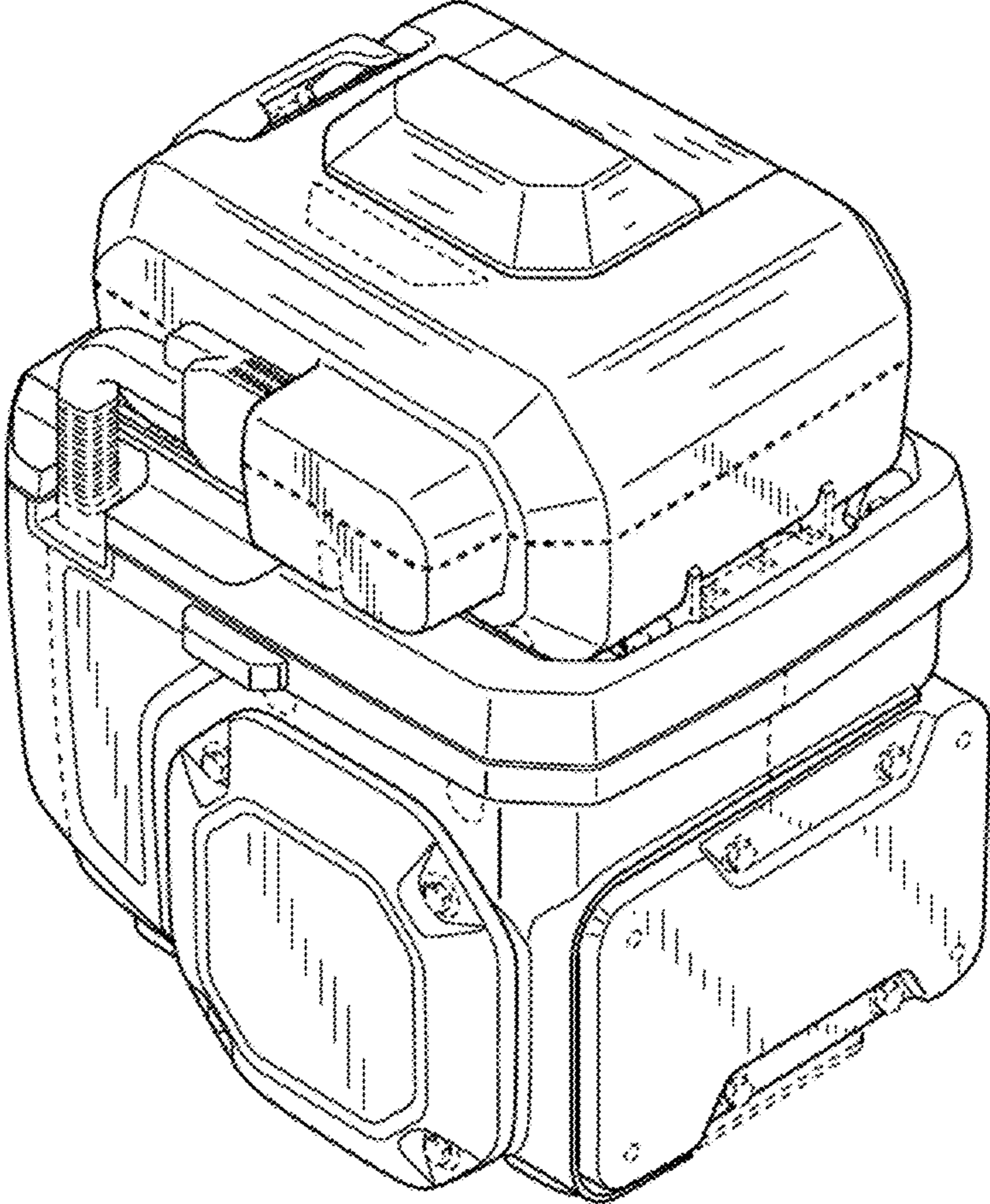

FIG. 2

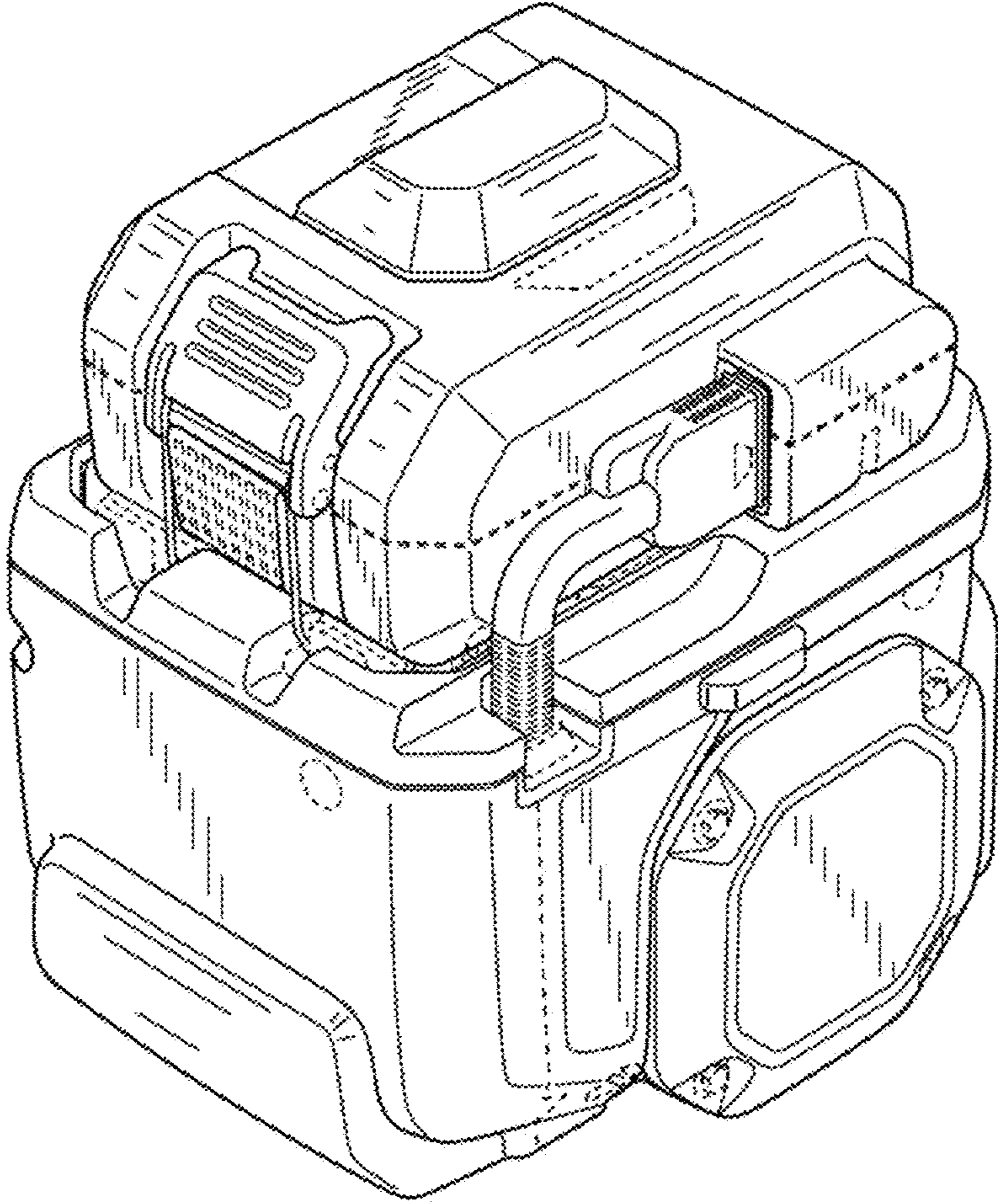

FIG. 3

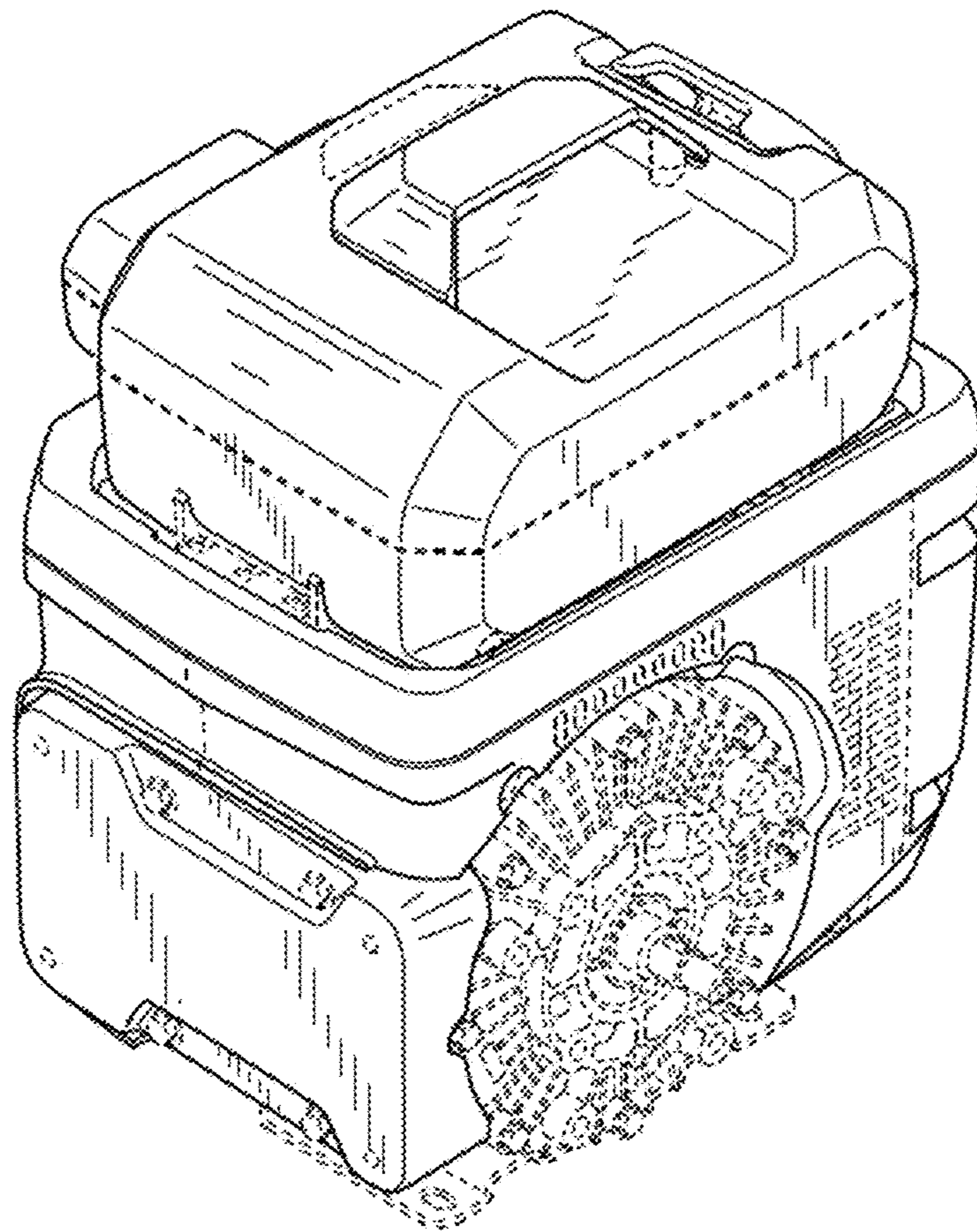

FIG. 4

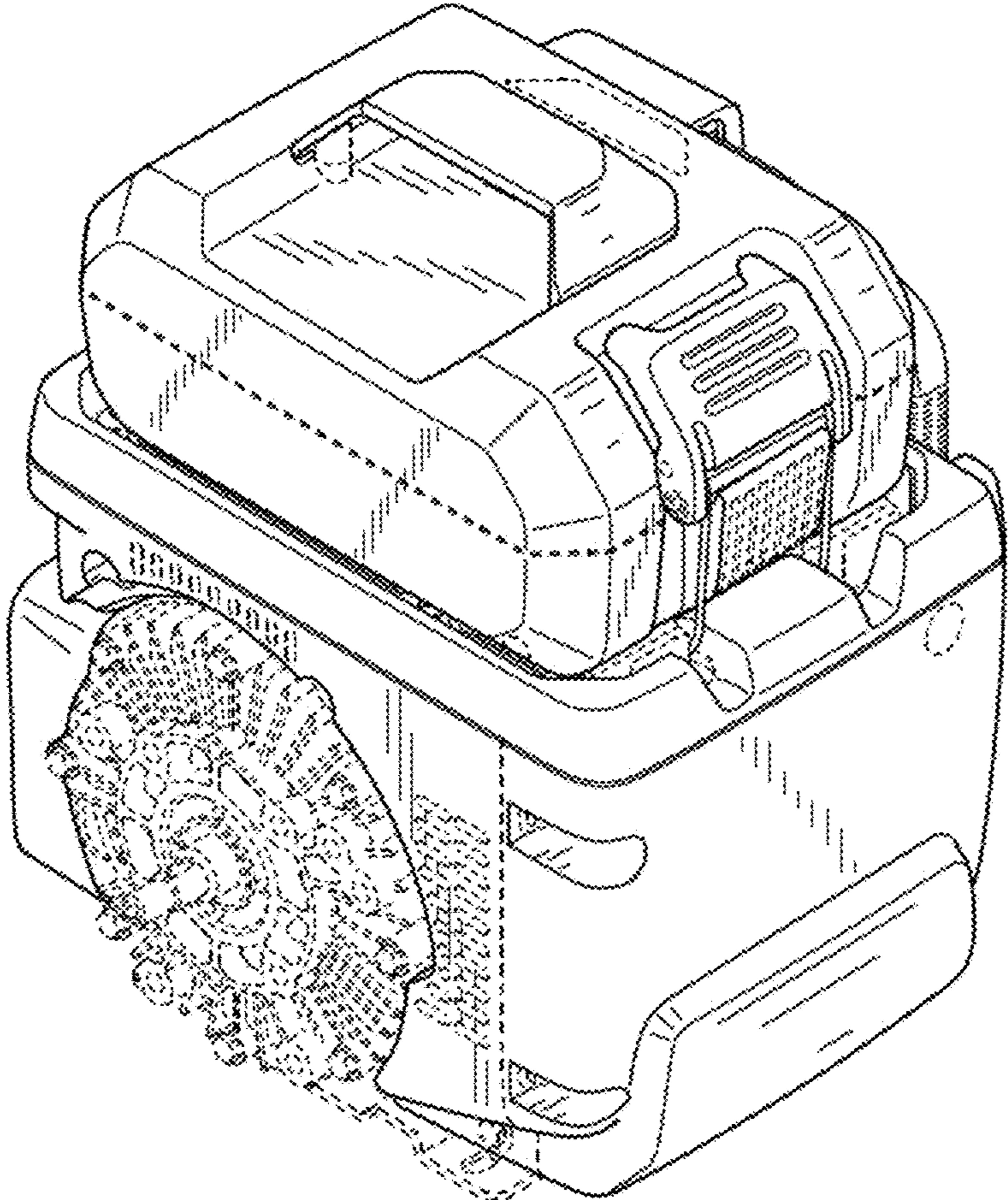

FIG. 5

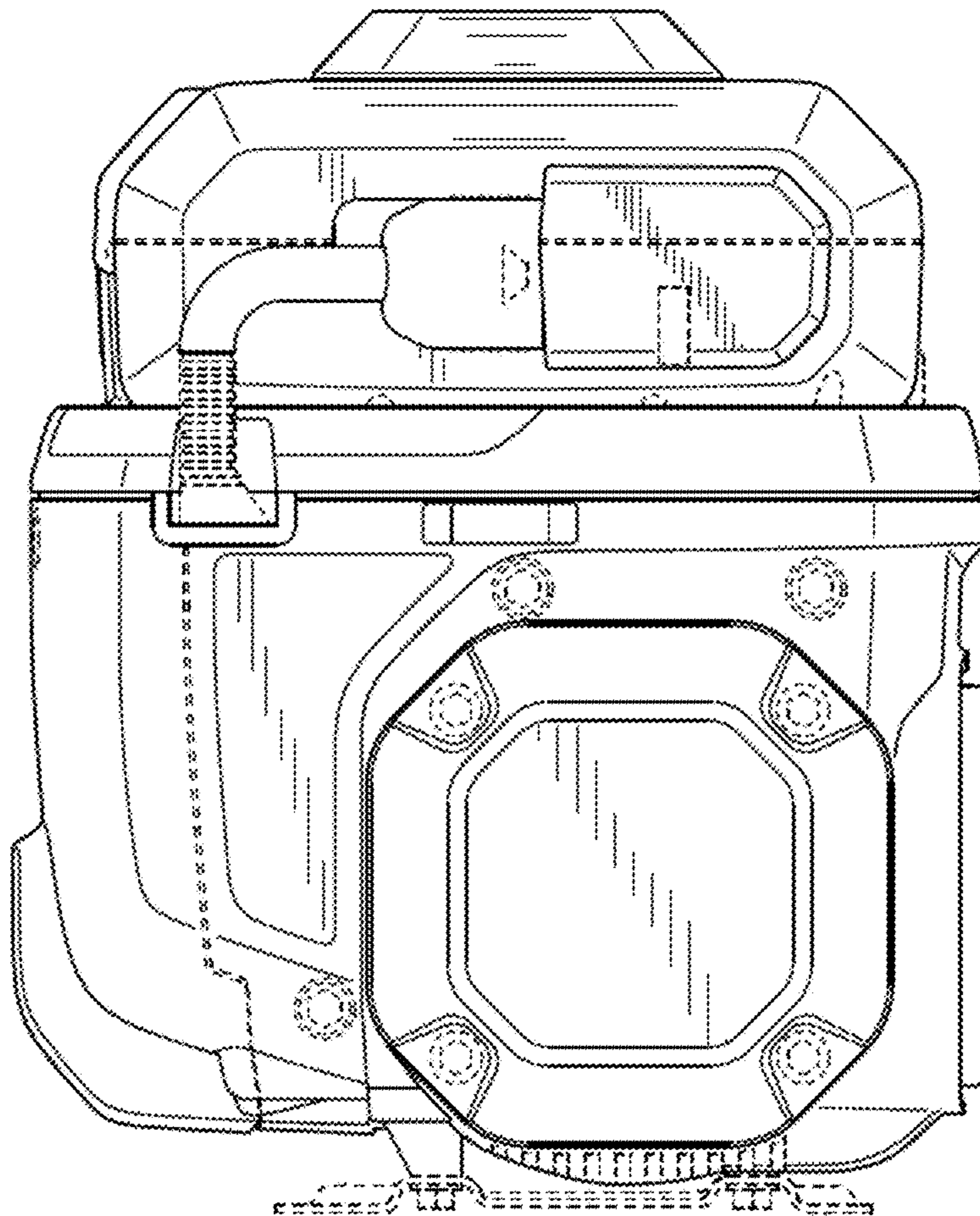

FIG. 6

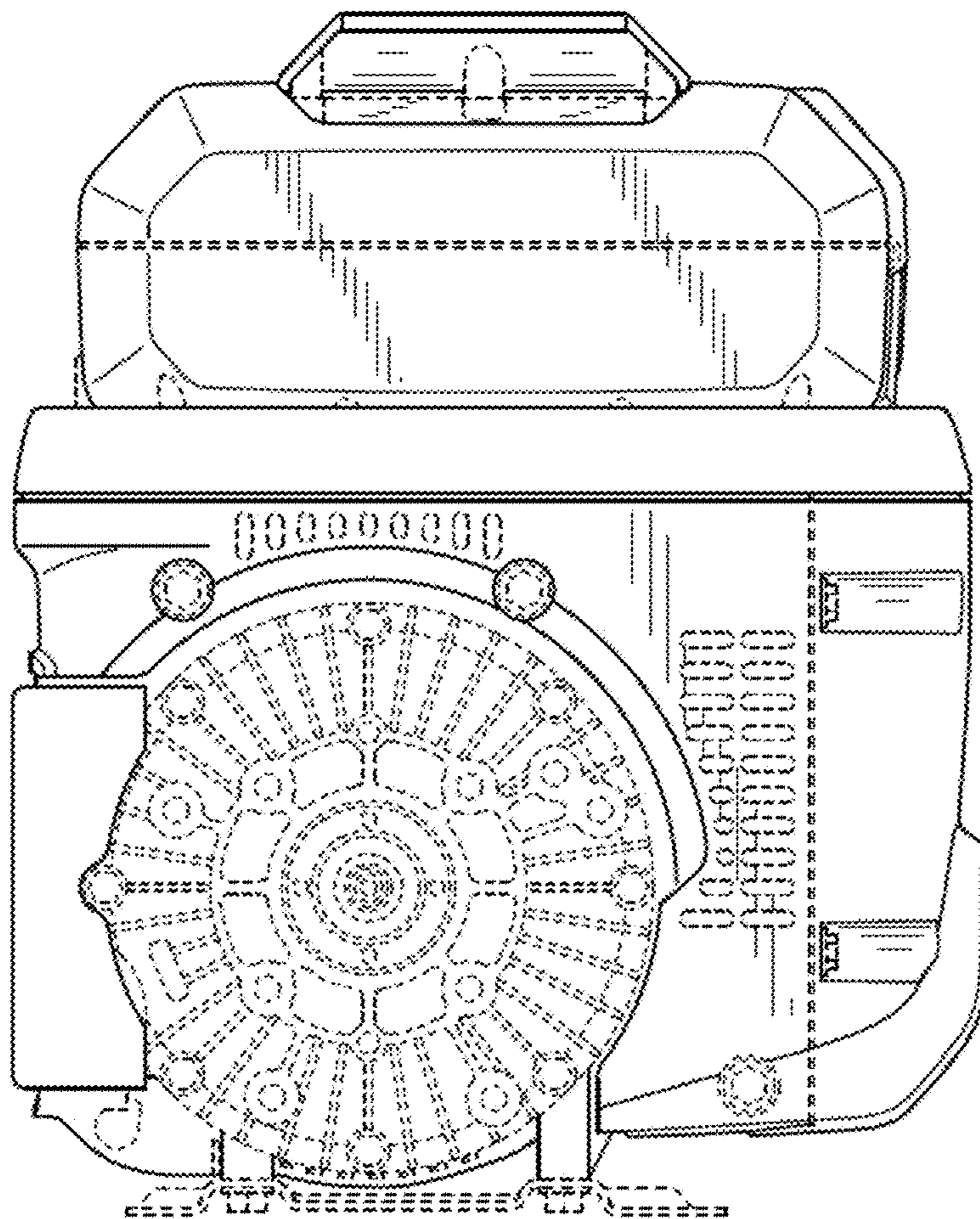

FIG. 7

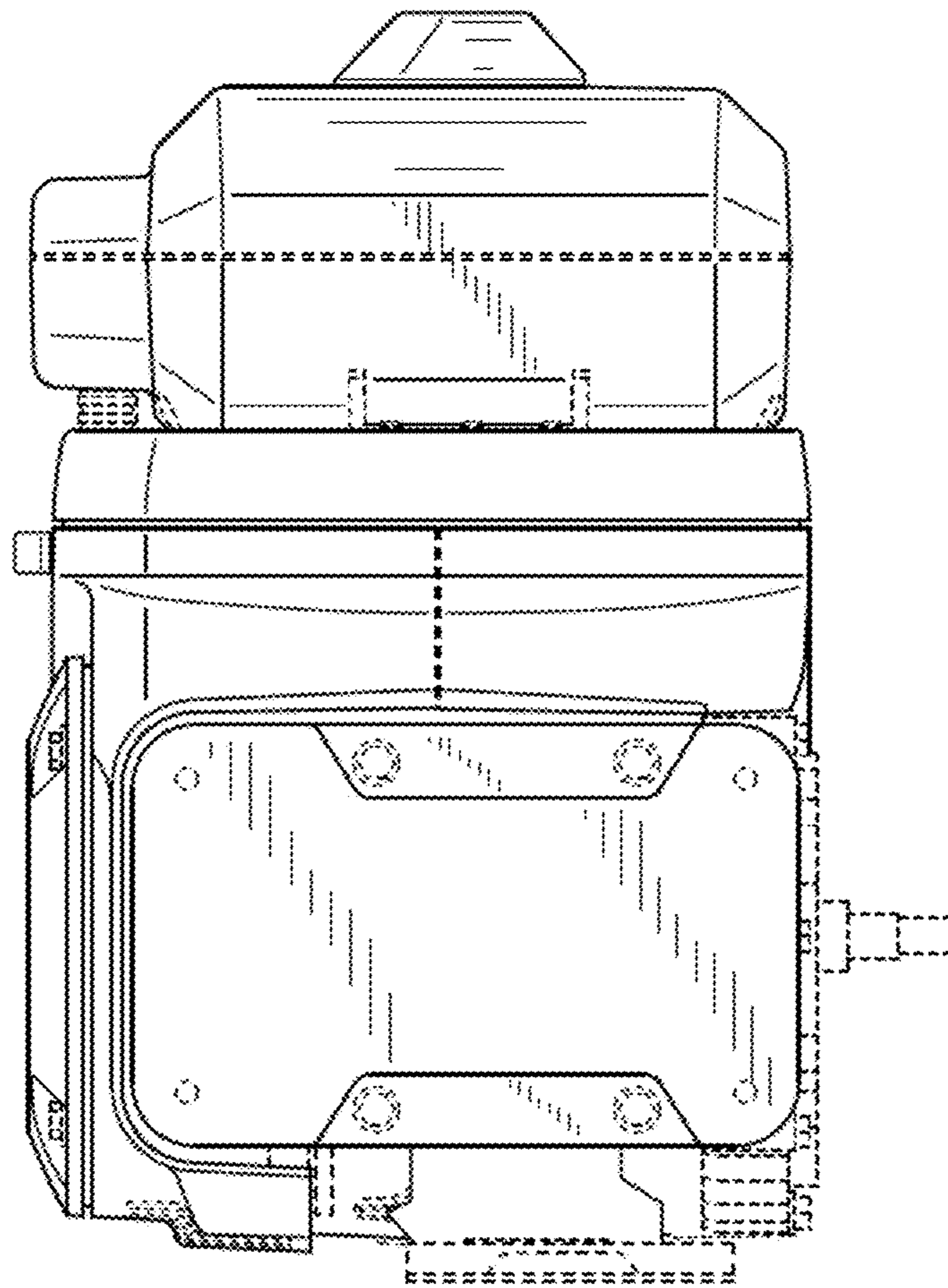

FIG. 8

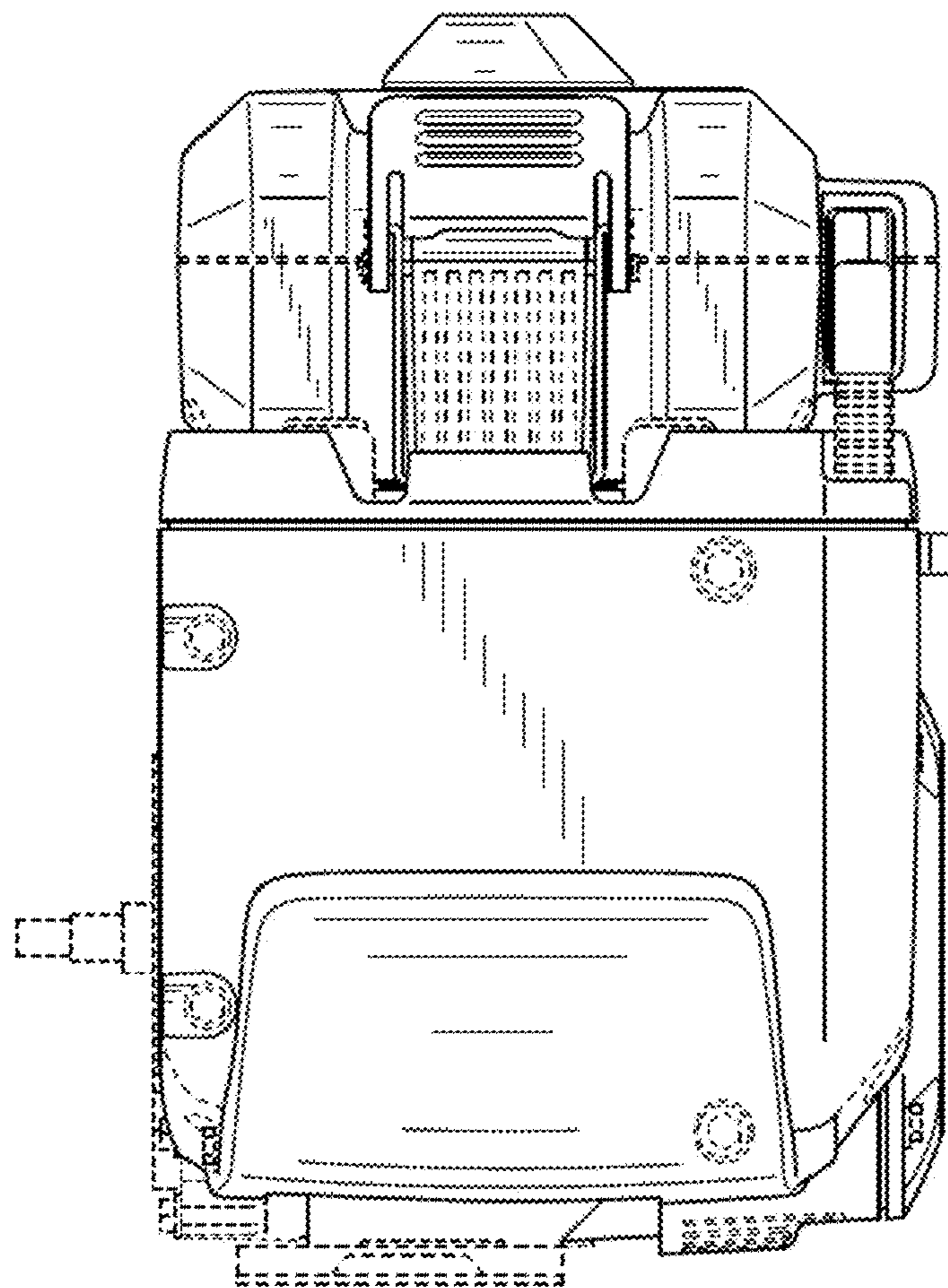

FIG. 9

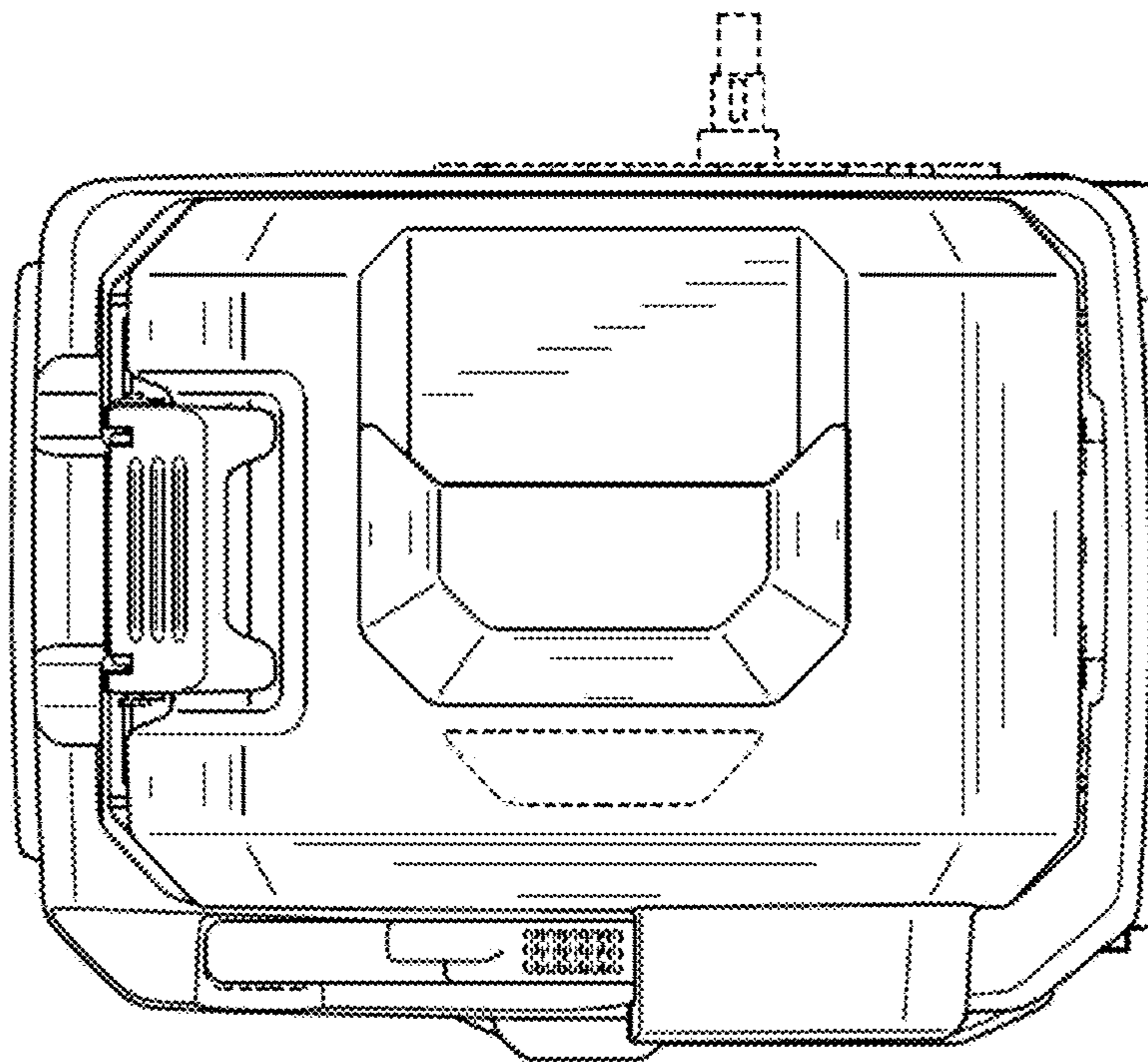

FIG. 10

