



US00D905544S

(12) **United States Design Patent** (10) **Patent No.:** **US D905,544 S**  
**Schroeder et al.** (45) **Date of Patent:** **\*\* Dec. 22, 2020**

(54) **EQUIPMENT MOUNTING PLATE**  
(71) Applicant: **Ferno-Washington, Inc.**, Wilmington, OH (US)  
(72) Inventors: **Timothy Paul Schroeder**, Mason, OH (US); **James C. West, III**, Midland, OH (US); **Peter Smolan**, Trencin (SK)  
(73) Assignee: **Ferno-Washington, Inc.**, Wilmington, OH (US)

716,852 A 12/1902 Baker  
1,055,050 A 3/1913 Knape  
1,055,201 A \* 3/1913 Mason ..... A47B 57/567  
248/244  
1,178,360 A 4/1916 Tudor  
1,263,918 A 4/1918 Miller  
1,288,010 A 12/1918 William  
1,576,034 A 3/1926 Butt  
1,702,937 A 2/1929 Friedemann  
(Continued)

(\*\*) Term: **15 Years**  
(21) Appl. No.: **29/712,873**  
(22) Filed: **Nov. 12, 2019**

**Related U.S. Application Data**

(63) Continuation of application No. 29/666,974, filed on Oct. 17, 2018, now Pat. No. Des. 868,569, which is a continuation of application No. 29/630,337, filed on Dec. 20, 2017, now Pat. No. Des. 835,499, which is a continuation of application No. 14/455,471, filed on Aug. 8, 2014, now Pat. No. 9,944,217, which is a continuation-in-part of application No. PCT/US2014/015898, filed on Feb. 11, 2014.

(51) **LOC (12) Cl.** ..... **08-05**  
(52) **U.S. Cl.**  
USPC ..... **D8/381**  
(58) **Field of Classification Search**  
USPC ..... 211/125, 187, 90.02, 90.03, 90.04;  
D8/354, 373, 381; D25/38.1, 123  
CPC ..... A47B 57/42; A47B 96/067  
See application file for complete search history.

(56) **References Cited**  
U.S. PATENT DOCUMENTS

269,985 A 1/1883 Joseph  
619,174 A 2/1899 Harry, II

**FOREIGN PATENT DOCUMENTS**

CH 432266 A 3/1967  
DE 2000967 B 7/1971  
(Continued)

*Primary Examiner* — Janice Hallmark  
*Assistant Examiner* — Harold E Blackwell, II  
(74) *Attorney, Agent, or Firm* — Dinsmore & Shohl, LLP

(57) **CLAIM**

The ornamental design for an equipment mounting plate, as shown and described.

**DESCRIPTION**

FIG. 1 is a top perspective view of an equipment mounting plate according to the present design;  
FIG. 2 is a top side view of the equipment mounting plate of FIG. 1;  
FIG. 3 is a bottom side view of the equipment mounting plate of FIG. 1;  
FIG. 4 is a side view of the equipment mounting plate of FIG. 1 and the opposite side being the same; and,  
FIG. 5 is a sectional view taken in the direction of line 5-5 of FIG. 1.

The long dash-short dash broken lines in the figures represent the bounds of the claimed design. The dash-dash broken lines in the figures illustrate portions of the equipment mounting plate which form no part of the claimed design.

**1 Claim, 5 Drawing Sheets**

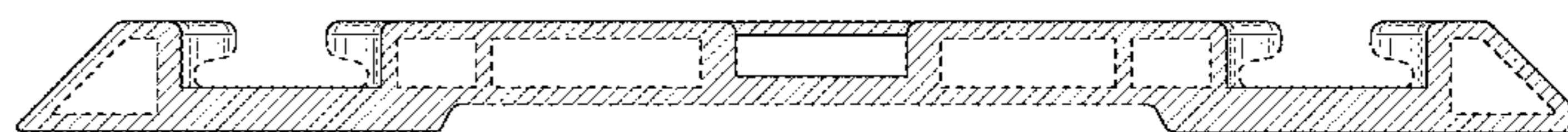
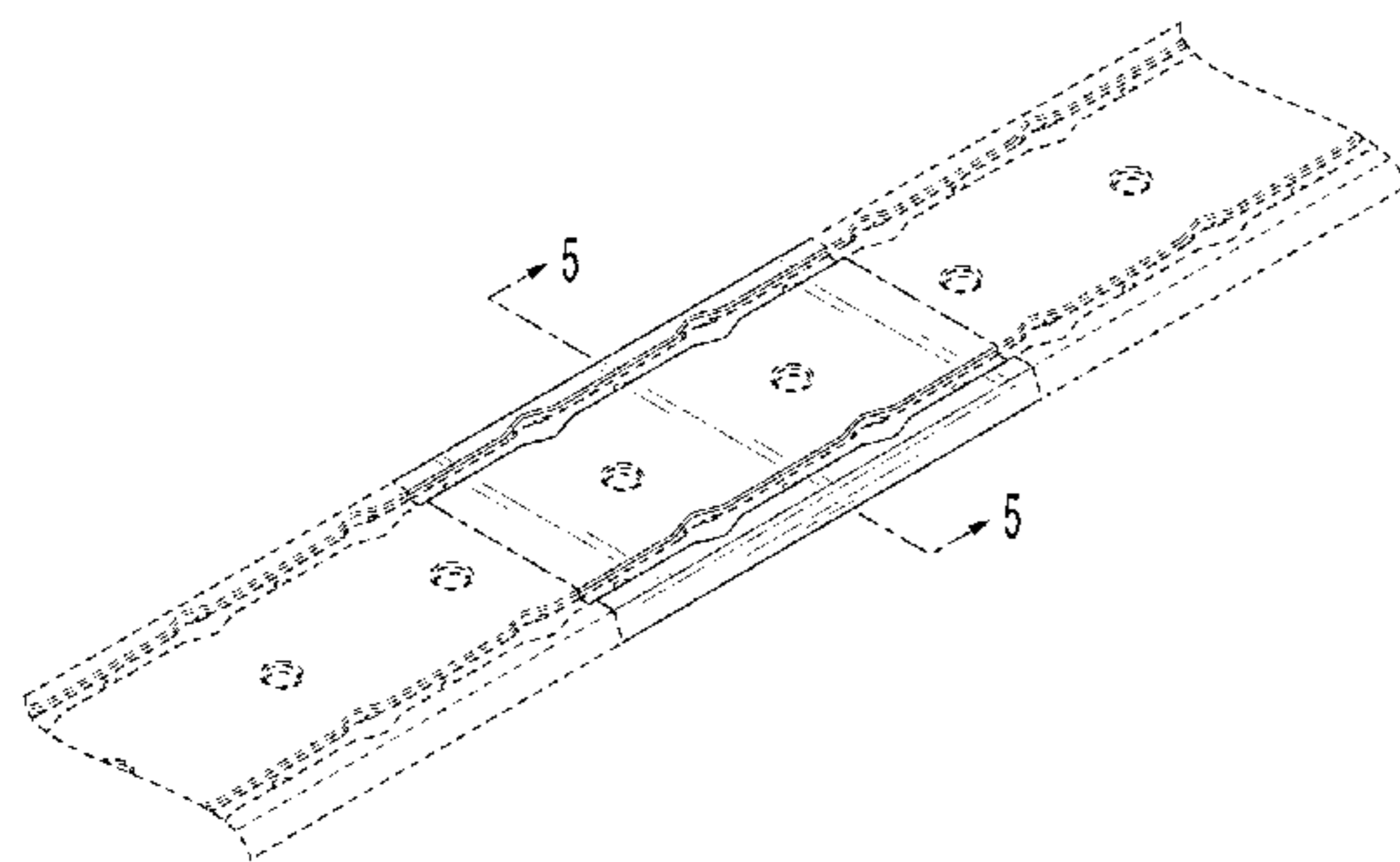

(56)

References Cited

U.S. PATENT DOCUMENTS

1,817,962 A	8/1931	Breuer	6,244,400 B1	6/2001	Bowers	
2,391,051 A	12/1945	Windsor	6,273,366 B1	8/2001	Sprenger et al.	
2,456,024 A	12/1948	Schofield	6,296,094 B1	10/2001	Knecht	
2,473,364 A	6/1949	Dickinson et al.	6,367,603 B1	4/2002	Tiramani et al.	
2,480,322 A	8/1949	Cozzoli	6,585,188 B2	7/2003	Alli	
2,556,076 A	6/1951	Evans et al.	6,595,379 B1	7/2003	Powell	
2,644,591 A	7/1953	McMahan	6,618,018 B1	9/2003	Sylvester et al.	
2,685,912 A	8/1954	Evans et al.	6,726,075 B1	4/2004	Patel et al.	
2,688,504 A	9/1954	Parker	6,746,138 B1	6/2004	Neeld et al.	
3,042,221 A	7/1962	Rasmussen	6,762,727 B2	7/2004	Rochford et al.	
3,116,773 A	1/1964	Kikas	6,789,714 B1	9/2004	Benson et al.	
3,204,998 A	9/1965	Hans	6,811,043 B2 *	11/2004	Perkins .....	A47B 21/06 211/94.01
3,358,300 A	12/1967	Smith	6,945,414 B1	9/2005	Stevens et al.	
3,375,936 A	4/1968	Kessler	7,000,810 B1	2/2006	Farmer	
3,392,848 A	7/1968	McConnell et al.	7,048,242 B2	5/2006	Oddsens, Jr.	
3,451,580 A	6/1969	Husby	7,097,204 B2	8/2006	Jessup et al.	
3,480,265 A	11/1969	Deve	7,228,977 B2 *	6/2007	Perkins .....	A47B 83/001 211/87.01
3,591,121 A	7/1971	Parris	7,234,619 B2	6/2007	Hicks et al.	
3,605,637 A	9/1971	Prete, Jr.	7,328,926 B1	2/2008	Myers et al.	
3,606,619 A	9/1971	Stollenwerk	7,502,226 B2	3/2009	Searby et al.	
3,613,900 A	10/1971	Chiu	7,507,005 B1	3/2009	Mier-Langner	
3,718,886 A	2/1973	Hoffmeister	7,600,619 B2	10/2009	Sapyta	
3,770,234 A	11/1973	Fovall	7,654,834 B1	2/2010	Mier-Langner et al.	
3,840,265 A	10/1974	Stirling et al.	7,669,945 B2	3/2010	Blersch et al.	
3,846,944 A	11/1974	Lambert	7,677,400 B2	3/2010	Bayazit et al.	
D235,181 S	5/1975	Brown	7,798,323 B1	9/2010	McCann et al.	
3,973,818 A	8/1976	Soquenne	7,946,771 B2	5/2011	Boneschanscher et al.	
4,114,947 A	9/1978	Nelson	7,984,889 B2	7/2011	Whitley et al.	
4,170,335 A	10/1979	King	8,167,131 B1	5/2012	Anderson	
4,173,382 A	11/1979	Booty	8,172,077 B1	5/2012	Gray	
4,178,032 A	12/1979	Hone	8,267,363 B2 *	9/2012	Begic .....	A47B 96/067 211/4
4,190,377 A	2/1980	Pleuss	8,276,795 B1	10/2012	Dean et al.	
4,210,355 A	7/1980	Legueu	8,387,783 B2	3/2013	Zack et al.	
D257,195 S	10/1980	Swett et al.	8,505,794 B2	8/2013	Ardigo	
4,230,432 A	10/1980	Howell	8,636,154 B2	1/2014	Chinn	
D257,709 S	12/1980	Lewis	8,701,952 B1	4/2014	Tripp	
4,256,424 A	3/1981	Knox et al.	8,776,454 B2 *	7/2014	Zuritis .....	F24S 25/65 52/173.3
D259,080 S	5/1981	Conti	8,807,376 B1	8/2014	Mastors et al.	
4,386,642 A	6/1983	Durbin	8,864,004 B2	10/2014	Crawford et al.	
4,397,432 A	8/1983	Resetar	8,992,238 B2	3/2015	Chinn	
4,423,817 A	1/1984	Monjo-Rufi	9,078,501 B2	7/2015	Johnson	
4,425,978 A	1/1984	Star	9,282,794 B2	3/2016	Farrelly	
4,458,864 A	7/1984	Colombo et al.	9,379,504 B2	6/2016	Chinn	
4,513,866 A	4/1985	Thomas	9,611,975 B2	4/2017	Chinn et al.	
4,568,050 A	2/1986	Radoy et al.	9,789,416 B2 *	10/2017	Fiebig .....	18/2
4,576,319 A	3/1986	Brown	9,861,178 B1	1/2018	Vanman et al.	
4,602,756 A	7/1986	Chatfield	9,944,217 B2	4/2018	Schroeder et al.	
4,677,794 A	7/1987	Parron et al.	D825,952 S	8/2018	Garcia	
4,763,360 A	8/1988	Daniels et al.	10,072,788 B2	9/2018	Chinn et al.	
4,783,034 A	11/1988	Ostrander et al.	D835,499 S *	12/2018	Schroeder .....	B60P 7/0815 D8/381
4,853,555 A	8/1989	Wheat	D850,651 S *	6/2019	Ward, Jr. ....	D25/38.1
4,915,435 A	4/1990	Levine	D868,569 S	12/2019	Schroeder et al.	
4,974,377 A	12/1990	Dominitz et al.	2003/0143052 A1	7/2003	Fehrle	
5,007,608 A	4/1991	Carroll, Jr.	2004/0178309 A1	9/2004	Crowley et al.	
5,157,409 A	10/1992	Hamin	2004/0253856 A1	12/2004	Hoffmann	
5,207,303 A	5/1993	Oswalt et al.	2005/0039644 A1	2/2005	Sheahan et al.	
5,383,629 A	1/1995	Morgan	2005/0232519 A1	10/2005	Grimes	
5,425,520 A	6/1995	Masumoto	2006/0243766 A1	11/2006	Lan	
5,490,703 A	2/1996	Hewko	2006/0255221 A1	11/2006	Tseng	
5,615,848 A	4/1997	Ceriani	2007/0056921 A1	3/2007	Lo	
5,732,867 A	3/1998	Perkins et al.	2007/0097617 A1	5/2007	Searby et al.	
5,732,965 A	3/1998	Wiley	2008/0023976 A1	1/2008	Myers et al.	
5,738,306 A	4/1998	Moss et al.	2008/0121730 A1	5/2008	Calkin	
5,755,478 A	5/1998	Kamiya et al.	2008/0169739 A1	7/2008	Goldenberg	
5,779,296 A	7/1998	Hewko	2008/0302553 A1	12/2008	Ross et al.	
5,785,277 A	7/1998	Manning et al.	2009/0014584 A1	1/2009	Rudduck et al.	
5,815,629 A	9/1998	Finzel et al.	2009/0014602 A1	1/2009	Frost	
5,833,095 A	11/1998	Russell et al.	2009/0140112 A1	6/2009	Carnevali	
5,850,891 A	12/1998	Olms et al.	2009/0165208 A1	7/2009	Reed et al.	
5,865,314 A	2/1999	Jacober	2010/0307649 A1	12/2010	Santos Dominguez	
5,886,674 A	3/1999	Yoshimi	2011/0147428 A1	6/2011	Crawford et al.	
5,988,409 A	11/1999	Gusdorf et al.	2012/0006873 A1	1/2012	Chinn	
6,000,509 A	12/1999	Chisholm	2012/0126075 A1	5/2012	Chinn et al.	
6,157,350 A	12/2000	House et al.	2013/0081233 A1	4/2013	Lu	
6,241,109 B1	6/2001	Kautz et al.				

(56)

**References Cited**

U.S. PATENT DOCUMENTS

2013/0193179 A1 8/2013 Davidson  
 2014/0016503 A1 1/2014 Altek et al.  
 2014/0073676 A1 3/2014 Kambe et al.  
 2014/0226315 A1 8/2014 Nicieja et al.  
 2014/0227892 A1 8/2014 Chinn  
 2014/0263502 A1 9/2014 Byham  
 2014/0374564 A1 12/2014 Schroeder et al.  
 2015/0344089 A1 12/2015 Bopanna et al.  
 2016/0031382 A1 2/2016 Chinn et al.  
 2017/0020249 A1 1/2017 Schroeder et al.  
 2017/0021775 A1 1/2017 Spector et al.  
 2017/0158145 A1 6/2017 Chinn et al.  
 2017/0202330 A1 7/2017 Schroeder et al.  
 2017/0209318 A1 7/2017 Schroeder et al.  
 2018/0073676 A1 3/2018 Schroeder et al.

FOREIGN PATENT DOCUMENTS

DE 3209091 A1 9/1983  
 DE 3209092 A1 9/1983  
 DE 3230905 A1 2/1984  
 DE 3910460 U1 12/1989  
 DE 19716046 A1 10/1998

DE 202006020143 U1 1/2008  
 DE 102009039471 A1 3/2011  
 DE 102010024544 A1 12/2011  
 EP 105675 A2 4/1984  
 EP 260726 A2 3/1988  
 EP 583491 A1 2/1994  
 EP 583492 A1 2/1994  
 EP 972616 A2 1/2000  
 EP 1790521 A1 5/2007  
 EP 1863119 A1 12/2007  
 EP 2206623 A1 7/2010  
 EP 2451418 A2 5/2012  
 EP 2614804 A1 7/2013  
 EP 2614805 A1 7/2013  
 FR 1085340 A 1/1955  
 FR 2481110 A1 10/1981  
 FR 2647323 A1 11/1990  
 FR 2649007 A1 1/1991  
 GB 1530794 A 11/1978  
 GB 2401541 A 11/2004  
 GB 2452083 A 2/2009  
 WO 3115178 A1 10/1991  
 WO 3927881 A1 6/1999  
 WO 0059466 A1 1/2000  
 WO 2006122351 A1 11/2006  
 WO 2011006163 A2 1/2011

\* cited by examiner

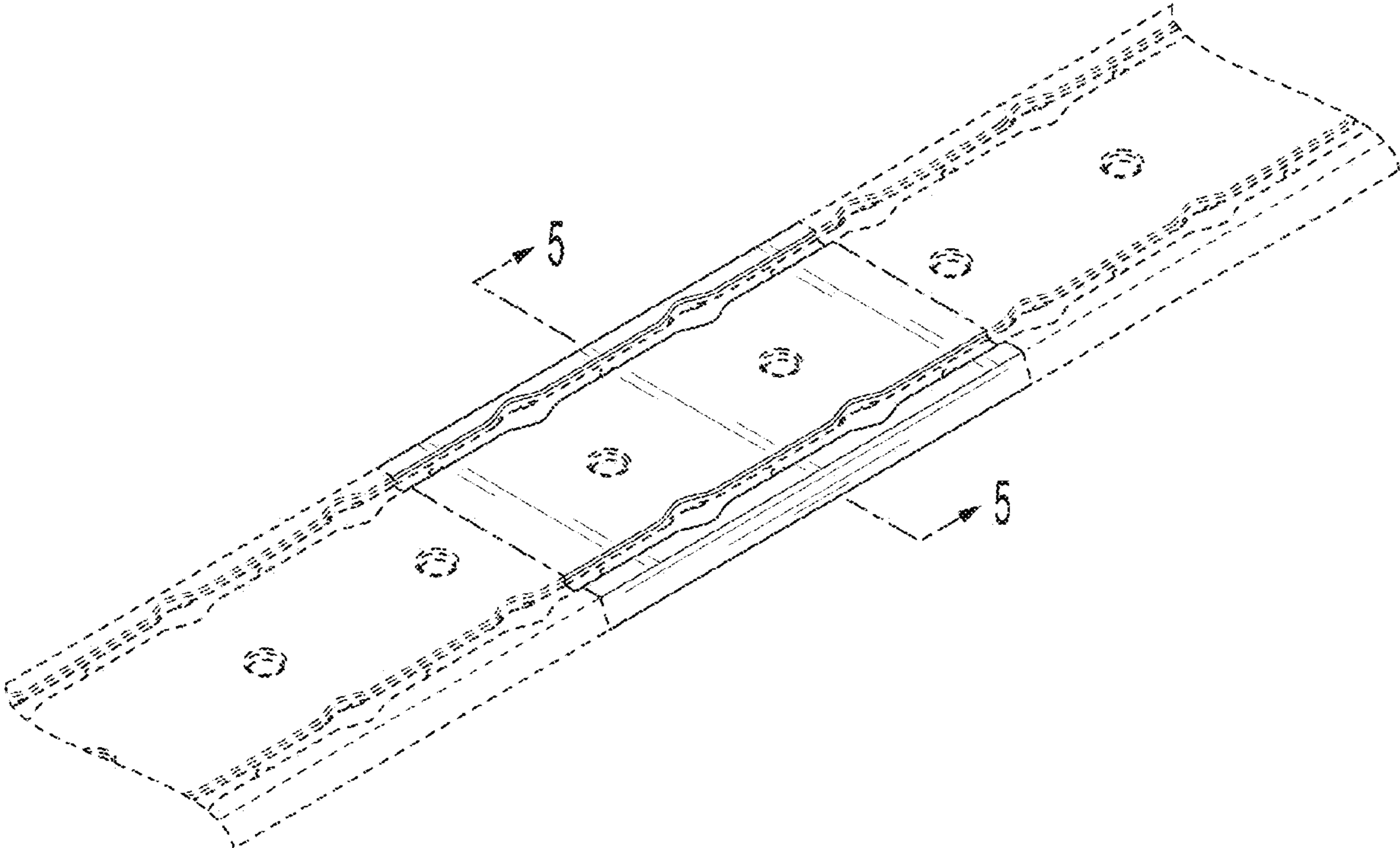

FIG. 1

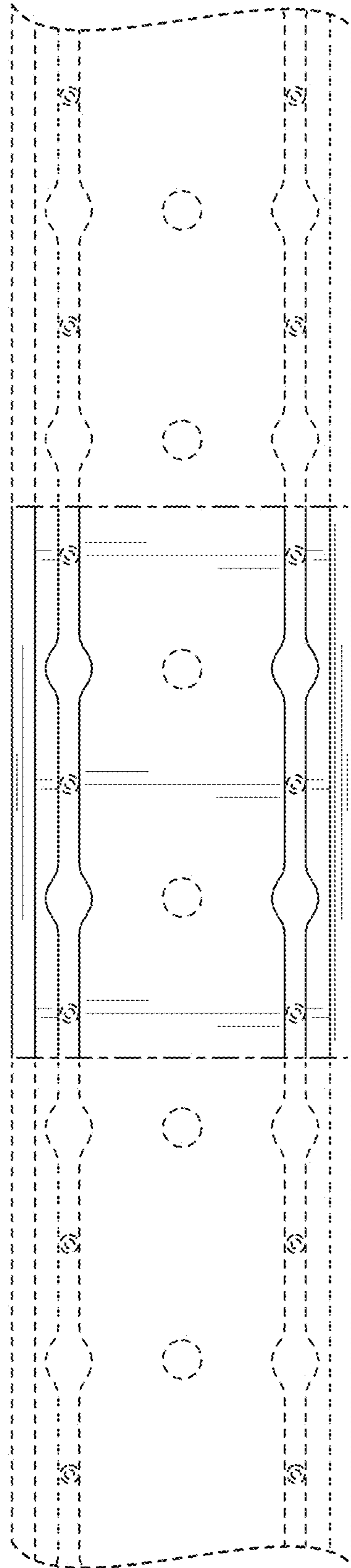

FIG. 2

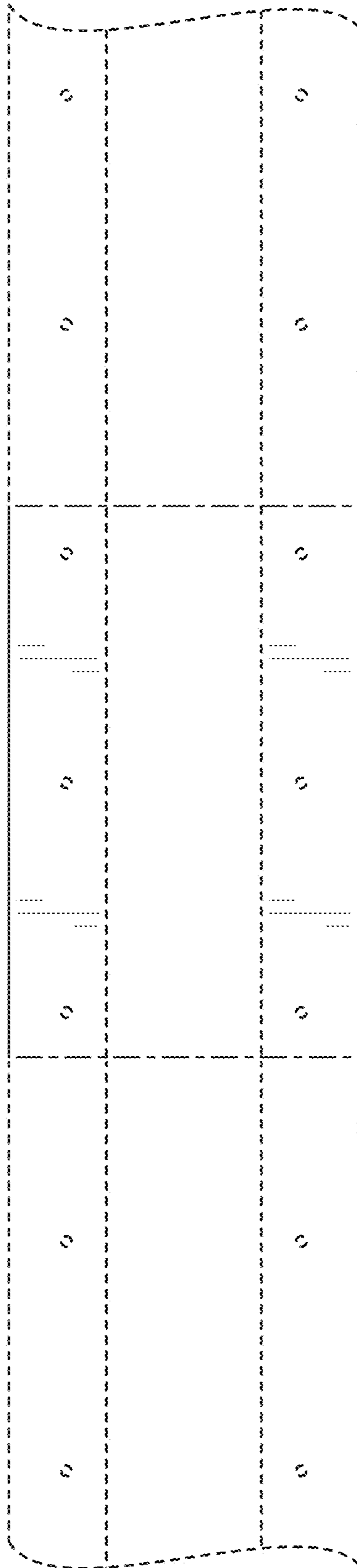

FIG. 3



FIG. 4

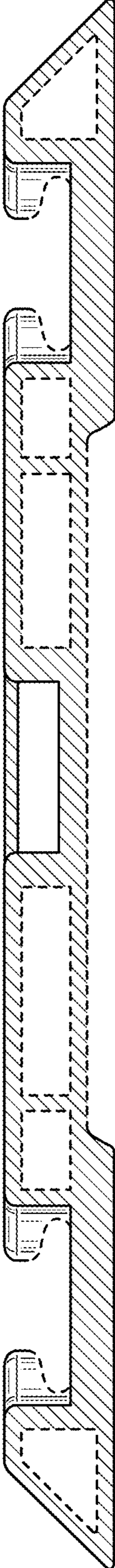

FIG. 5