



US00D905327S

(12) **United States Design Patent** (10) **Patent No.:** **US D905,327 S**  
**Williams et al.** (45) **Date of Patent:** **\*\* Dec. 15, 2020**

(54) **LIGHT FIXTURE**

FOREIGN PATENT DOCUMENTS

(71) Applicant: **DMF Inc.**, Carson, CA (US)

CA 2243934 C 1/1999  
CA 2502637 A1 9/2005

(72) Inventors: **Vincent Williams**, Torrance, CA (US);  
**Michael Danesh**, Carson, CA (US)

(Continued)

(73) Assignee: **DMF, Inc.**, Carson, CA (US)

OTHER PUBLICATIONS

(\*\*) Term: **15 Years**

Maxim Lighting International, "Wafer LED 7" RD 3000K Wall/  
Flush Mount", undated.

(21) Appl. No.: **29/648,046**

(Continued)

(22) Filed: **May 17, 2018**

*Primary Examiner* — Natasha Vujcic

(51) **LOC (12) Cl.** ..... **26-05**

(74) *Attorney, Agent, or Firm* — Smith Baluch LLP

(52) **U.S. Cl.**

(57) **CLAIM**

USPC ..... **D26/142**

We claim the ornamental design for a light fixture, as shown  
and described.

(58) **Field of Classification Search**

**DESCRIPTION**

USPC ..... D26/72, 74, 76, 78–83, 85, 86, 88, 90,  
D26/93, 111, 113, 118, 119, 120, 121,  
D26/122, 138, 139, 140, 141, 142, 152  
CPC ..... F21S 2/00; F21S 4/00; F21S 4/003; F21S  
4/005; F21S 4/006; F21S 4/007; F21S  
4/008; F21S 6/00; F21S 8/00; F21S  
8/024; F21S 8/026; F21S 8/031; F21S  
8/033; F21S 8/035–037; F21S 8/04; F21S  
8/043; F21S 8/063

FIG. 1 is a top, front, right perspective view of an embodi-  
ment of the claimed design;  
FIG. 2 is a bottom, front, right perspective view thereof;  
FIG. 3 is a right side elevation view thereof;  
FIG. 4 is a left side elevation view thereof;  
FIG. 5 is a front elevation view thereof;  
FIG. 6 is a rear elevation view thereof;  
FIG. 7 is a top plan view thereof;  
FIG. 8 is a bottom plan view thereof;  
FIG. 9 is a top, front, right perspective view of a second  
embodiment of the claimed design;  
FIG. 10 is a bottom, front, right perspective view thereof;  
FIG. 11 is a right side elevation view thereof;  
FIG. 12 is a left side elevation view thereof;  
FIG. 13 is a front elevation view thereof;  
FIG. 14 is a rear elevation view thereof;  
FIG. 15 is a top plan view thereof; and,  
FIG. 16 is a bottom plan view thereof.

See application file for complete search history.

The broken lines in the drawings illustrate portions of the  
light fixture which form no part of the claimed design.

(56) **References Cited**

U.S. PATENT DOCUMENTS

1,133,535 A 3/1915 Cain et al.  
1,471,340 A 10/1923 Knight  
1,856,356 A 5/1932 Owen  
2,038,784 A 4/1936 Ghadiali  
2,179,161 A 11/1939 Rambusch  
2,197,737 A 4/1940 Appleton  
2,352,913 A 7/1944 Morrill  
2,528,989 A 11/1950 Ammells  
2,597,595 A 5/1952 Ordas

(Continued)

**1 Claim, 10 Drawing Sheets**

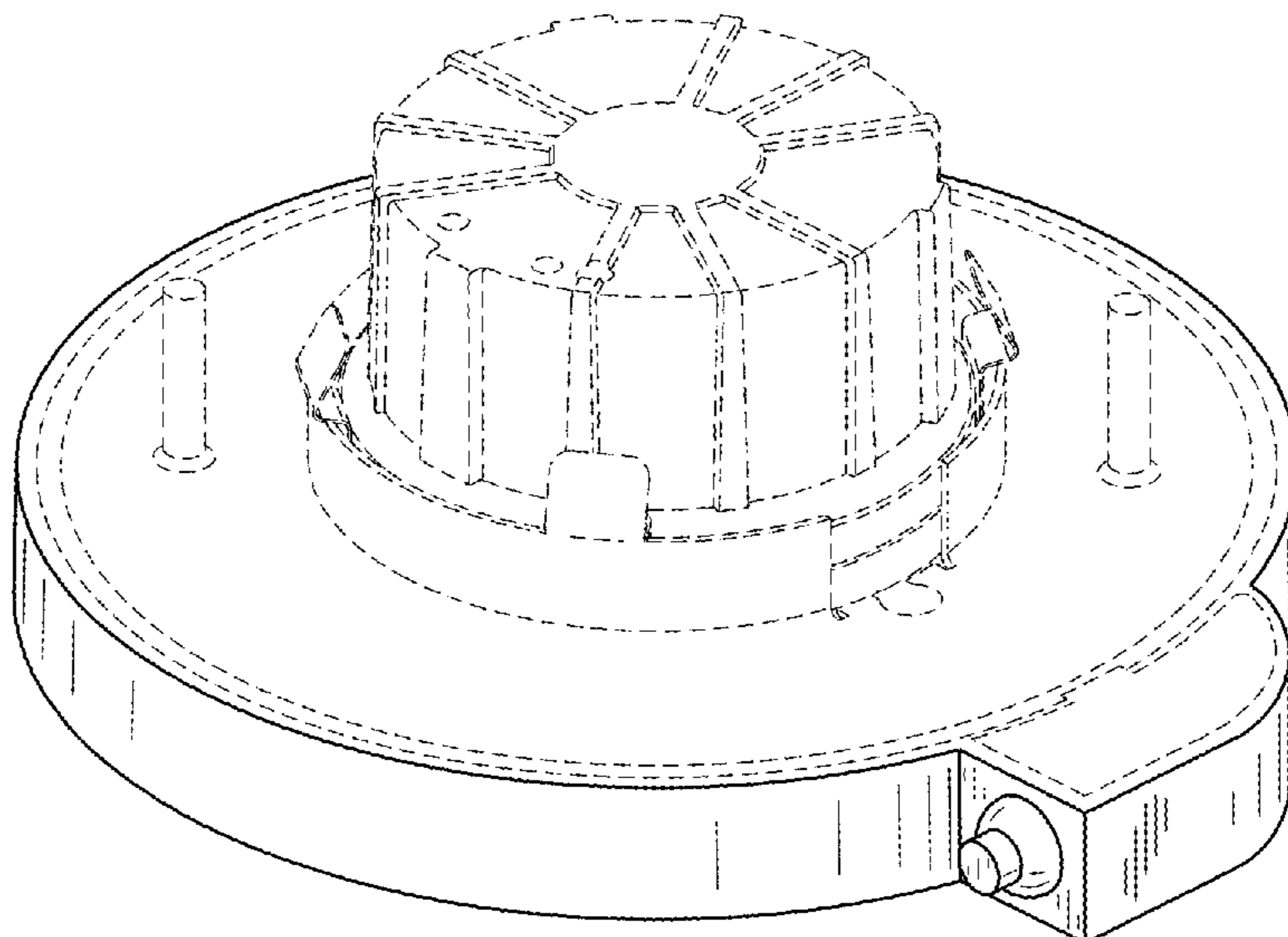

(56)

**References Cited**

U.S. PATENT DOCUMENTS

|   |   |
|---|---|
| <p>2,642,246 A      6/1953    Stephans<br/>                 2,670,919 A      3/1954    Esoldi<br/>                 2,697,535 A     12/1954   Olson<br/>                 2,758,810 A      8/1956    Good<br/>                 D180,844 S      8/1957    Poliakoff<br/>                 2,802,933 A      8/1957    Harry<br/>                 2,998,512 A      8/1961    Duchene et al.<br/>                 3,023,920 A      3/1962    Cook et al.<br/>                 3,057,993 A     10/1962   Gellert<br/>                 3,104,087 A      9/1963    Joseph et al.<br/>                 3,214,126 A     10/1965   Roos<br/>                 3,422,261 A      1/1969    McGinty<br/>                 3,460,299 A      8/1969    Wilson<br/>                 3,650,046 A      3/1972    Skinner<br/>                 3,675,807 A      7/1972    Lund et al.<br/>                 3,700,885 A     10/1972   Bobrick<br/>                 3,711,053 A      1/1973    Drake<br/>                 D227,989 S      7/1973    Geisel<br/>                 3,773,968 A     11/1973   Copp<br/>                 3,812,342 A      5/1974    McNamara, Jr.<br/>                 3,836,766 A      9/1974    Auerbach<br/>                 3,874,035 A      4/1975    Schuplin<br/>                 3,913,773 A     10/1975   Copp et al.<br/>                 D245,905 S      9/1977    Taylor<br/>                 4,088,827 A      5/1978    Kohaut<br/>                 4,154,218 A      5/1979    Hulet<br/>                 4,154,219 A      5/1979    Gupta et al.<br/>                 4,176,758 A     12/1979   Glick<br/>                 4,280,169 A      7/1981    Allen<br/>                 4,399,497 A      8/1983    Druffel<br/>                 4,450,512 A      5/1984    Kristofek<br/>                 4,520,435 A      5/1985    Baldwin<br/>                 4,539,629 A      9/1985    Poppenheimer<br/>                 4,601,145 A      7/1986    Wilcox<br/>                 4,667,840 A      5/1987    Lindsey<br/>                 4,723,747 A      2/1988    Karp et al.<br/>                 4,729,080 A      3/1988    Fremont et al.<br/>                 4,754,377 A      6/1988    Wenman<br/>                 4,770,311 A      9/1988    Wang<br/>                 4,880,128 A     11/1989   Jorgensen<br/>                 4,910,651 A      3/1990    Montanez<br/>                 4,919,292 A      4/1990    Hsu<br/>                 4,929,187 A      5/1990    Hudson et al.<br/>                 4,930,054 A      5/1990    Krebs<br/>                 5,044,582 A      9/1991    Walters<br/>                 5,216,203 A      6/1993    Gower<br/>                 5,222,800 A      6/1993    Chan et al.<br/>                 5,239,132 A      8/1993    Bartow<br/>                 5,250,269 A     10/1993   Langer<br/>                 5,266,050 A     11/1993   O'Neil et al.<br/>                 5,303,894 A      4/1994    Deschamps et al.<br/>                 5,382,752 A      1/1995    Reyhan et al.<br/>                 5,420,376 A      5/1995    RajECKi et al.<br/>                 5,444,606 A      8/1995    Barnes et al.<br/>                 5,465,199 A     11/1995   Bray et al.<br/>                 5,505,419 A      4/1996    Gabrius<br/>                 5,544,870 A      8/1996    Kelley et al.<br/>                 5,562,343 A     10/1996   Chan et al.<br/>                 5,571,993 A     11/1996   Jones et al.<br/>                 5,580,158 A     12/1996   Aubrey et al.<br/>                 5,588,737 A     12/1996   Kusmer<br/>                 D377,843 S *     2/1997    Schering ..... D26/138<br/>                 5,603,424 A      2/1997    Bordwell et al.<br/>                 5,609,408 A      3/1997    Targetti<br/>                 5,613,338 A      3/1997    Esposito<br/>                 D381,111 S      7/1997    Lecluze<br/>                 5,662,413 A      9/1997    Akiyama<br/>                 D386,277 S     11/1997   Lecluze<br/>                 5,690,423 A     11/1997   Hentz et al.<br/>                 D387,466 S     12/1997   Lecluze<br/>                 5,738,436 A      4/1998    Cummings et al.<br/>                 D400,281 S *   10/1998   Kerr ..... D26/74<br/>                 5,836,678 A     11/1998   Wright et al.<br/>                 5,942,726 A      8/1999    Reiker<br/>                 5,944,412 A      8/1999    Janos et al.</p> | <p>5,957,573 A      9/1999    Wedekind et al.<br/>                 5,975,323 A     11/1999   Turan<br/>                 6,082,878 A      7/2000    Doubek et al.<br/>                 6,105,334 A      8/2000    Monson et al.<br/>                 6,161,910 A     12/2000   Reisenauer et al.<br/>                 6,170,685 B1     1/2001    Currier<br/>                 6,170,965 B1     1/2001    Kotovsky<br/>                 6,174,076 B1     1/2001    Petrakis et al.<br/>                 6,176,599 B1     1/2001    Farzen<br/>                 6,267,491 B1     7/2001    Parrigin<br/>                 6,332,597 B1   12/2001   Korcz et al.<br/>                 6,350,043 B1     2/2002    Gloisten<br/>                 6,350,046 B1     2/2002    Lau<br/>                 6,364,511 B1     4/2002    Cohen<br/>                 6,375,338 B1     4/2002    Cummings et al.<br/>                 6,402,112 B1     6/2002    Thomas et al.<br/>                 D461,455 S       8/2002    Forbes<br/>                 D465,061 S *   10/2002   Guthrie ..... D23/269<br/>                 6,461,016 B1   10/2002   Jamison et al.<br/>                 6,474,846 B1   11/2002   Kelmelis et al.<br/>                 6,491,413 B1   12/2002   Benesohn<br/>                 D468,697 S      1/2003    Straub, Jr.<br/>                 D470,970 S      2/2003    Huang<br/>                 6,515,313 B1     2/2003    Ibbetson et al.<br/>                 6,521,833 B1     2/2003    DeFreitas<br/>                 D471,657 S      3/2003    Huang<br/>                 6,583,573 B2     6/2003    Bierman<br/>                 D477,104 S *     7/2003    Wang ..... D26/72<br/>                 6,585,389 B2     7/2003    Bonazzi<br/>                 6,600,175 B1     7/2003    Baretz et al.<br/>                 D478,872 S      8/2003    Heggem<br/>                 6,632,006 B1   10/2003   Rippel et al.<br/>                 6,657,236 B1   12/2003   Thibeault et al.<br/>                 6,666,419 B1   12/2003   Vrame<br/>                 D487,600 S      3/2004    Fickas<br/>                 D488,583 S      4/2004    Benghozi<br/>                 6,719,438 B2     4/2004    Sevrack et al.<br/>                 6,758,578 B1     7/2004    Chou<br/>                 6,777,615 B1     8/2004    Gretz<br/>                 6,779,908 B1     8/2004    Ng<br/>                 6,827,229 B2   12/2004   Dinh et al.<br/>                 6,838,618 B2     1/2005    Newbold et al.<br/>                 6,906,352 B2     6/2005    Edmond et al.<br/>                 D509,314 S      9/2005    Rashidi<br/>                 6,948,829 B2     9/2005    Verdes et al.<br/>                 6,958,497 B2   10/2005   Emerson et al.<br/>                 6,964,501 B2   11/2005   Ryan<br/>                 6,967,284 B1   11/2005   Gretz<br/>                 D516,235 S      2/2006    Rashidi<br/>                 7,025,476 B2     4/2006    Leadford<br/>                 7,025,477 B2     4/2006    Blessing<br/>                 7,064,269 B2     6/2006    Smith<br/>                 D528,673 S      9/2006    Maxik et al.<br/>                 7,102,172 B2     9/2006    Lynch<br/>                 D531,740 S     11/2006   Maxik<br/>                 D532,532 S     11/2006   Maxik<br/>                 7,148,420 B1   12/2006   Johnson et al.<br/>                 7,148,632 B2   12/2006   Berman et al.<br/>                 7,152,985 B2   12/2006   Benitez et al.<br/>                 7,154,040 B1   12/2006   Tompkins<br/>                 7,170,015 B1     1/2007    Roesch et al.<br/>                 D536,349 S      2/2007    Humber et al.<br/>                 D537,039 S      2/2007    Pincek<br/>                 7,181,378 B2     2/2007    Benitez et al.<br/>                 D539,229 S      3/2007    Murphey<br/>                 7,186,008 B2     3/2007    Patti<br/>                 7,190,126 B1     3/2007    Paton<br/>                 7,211,833 B2     5/2007    Slater et al.<br/>                 7,213,940 B1     5/2007    Van De Ven et al.<br/>                 7,234,674 B2     6/2007    Rippel et al.<br/>                 D547,889 S      7/2007    Huang<br/>                 D552,969 S     10/2007   Bobrowski et al.<br/>                 D553,267 S     10/2007   Yuen<br/>                 D555,106 S     11/2007   Pape et al.<br/>                 D556,144 S     11/2007   Dinh<br/>                 7,297,870 B1   11/2007   Sartini<br/>                 7,312,474 B2   12/2007   Emerson et al.<br/>                 7,320,536 B2     1/2008    Petrakis et al.<br/>                 D561,372 S      2/2008    Yan</p> |
|---|---|



(56)

References Cited

U.S. PATENT DOCUMENTS

|              |         |                        |              |         |                             |
|--------------|---------|------------------------|--------------|---------|-----------------------------|
| D691,315 S   | 10/2013 | Samson                 | D744,723 S   | 12/2015 | Yoo                         |
| D691,763 S   | 10/2013 | Hand et al.            | 9,217,560 B2 | 12/2015 | Harbers et al.              |
| 8,550,669 B2 | 10/2013 | Macwan et al.          | 9,222,661 B2 | 12/2015 | Kim et al.                  |
| D693,043 S   | 11/2013 | Schmalfluss et al.     | 9,239,131 B1 | 1/2016  | Wronski et al.              |
| D693,517 S   | 11/2013 | Davis                  | D748,842 S * | 2/2016  | Sakurai ..... D26/89        |
| D694,456 S   | 11/2013 | Rowlette et al.        | 9,285,103 B2 | 3/2016  | Van De Ven et al.           |
| 8,573,816 B2 | 11/2013 | Negley et al.          | 9,291,319 B2 | 3/2016  | Kathawate et al.            |
| D695,441 S   | 12/2013 | Lui et al.             | 9,301,362 B2 | 3/2016  | Dohn et al.                 |
| D695,941 S   | 12/2013 | Rashidi                | D754,078 S   | 4/2016  | Baldwin et al.              |
| D696,446 S   | 12/2013 | Huh                    | D754,079 S   | 4/2016  | Baldwin et al.              |
| D696,447 S   | 12/2013 | Huh                    | D754,605 S   | 4/2016  | McMillan                    |
| D696,448 S   | 12/2013 | Huh                    | 9,303,812 B2 | 4/2016  | Green et al.                |
| 8,602,601 B2 | 12/2013 | Khazi et al.           | 9,310,038 B2 | 4/2016  | Athalye                     |
| D698,067 S   | 1/2014  | Rashidi                | 9,310,052 B1 | 4/2016  | Shum                        |
| D698,068 S   | 1/2014  | Rashidi                | 9,322,543 B2 | 4/2016  | Hussell et al.              |
| 8,622,361 B2 | 1/2014  | Wronski                | D756,025 S   | 5/2016  | Wronski et al.              |
| D698,985 S   | 2/2014  | Lopez et al.           | 9,347,655 B2 | 5/2016  | Boomgaarden et al.          |
| D699,384 S   | 2/2014  | Rashidi                | 9,366,418 B2 | 6/2016  | Gifford                     |
| D699,687 S   | 2/2014  | Baldwin et al.         | 9,371,966 B2 | 6/2016  | Rowlette, Jr. et al.        |
| D700,387 S   | 2/2014  | Snell                  | D762,181 S   | 7/2016  | Lin                         |
| 8,641,243 B1 | 2/2014  | Rashidi                | 9,395,051 B2 | 7/2016  | Hussell et al.              |
| 8,659,034 B2 | 2/2014  | Baretz et al.          | D762,906 S   | 8/2016  | Jeswani et al.              |
| D700,737 S * | 3/2014  | Campagna ..... D26/142 | D764,079 S   | 8/2016  | Wu                          |
| D701,175 S   | 3/2014  | Baldwin et al.         | 9,417,506 B1 | 8/2016  | Tirosh                      |
| D701,466 S   | 3/2014  | Clifford et al.        | D766,185 S   | 9/2016  | Hagarty                     |
| 8,672,518 B2 | 3/2014  | Boomgaarden et al.     | D767,199 S   | 9/2016  | Wronski et al.              |
| D702,867 S   | 4/2014  | Kim et al.             | 9,447,917 B1 | 9/2016  | Wronski et al.              |
| D703,843 S   | 4/2014  | Cheng                  | 9,447,953 B2 | 9/2016  | Lawlor                      |
| 8,684,569 B2 | 4/2014  | Pickard et al.         | D768,325 S   | 10/2016 | Xu                          |
| D705,472 S   | 5/2014  | Huh                    | D768,326 S   | 10/2016 | Guzzini                     |
| 8,727,582 B2 | 5/2014  | Brown et al.           | D769,501 S   | 10/2016 | Jeswani et al.              |
| D707,386 S * | 6/2014  | McKenzie ..... D26/142 | D770,065 S   | 10/2016 | Tittle                      |
| D708,381 S   | 7/2014  | Rashidi                | D770,084 S * | 10/2016 | Salomon ..... D26/138       |
| 8,777,449 B2 | 7/2014  | Van De Ven et al.      | 9,476,552 B2 | 10/2016 | Myers et al.                |
| D710,529 S   | 8/2014  | Lopez et al.           | D770,673 S * | 11/2016 | Hasan ..... D26/138         |
| 8,801,217 B2 | 8/2014  | Oehle et al.           | 9,488,324 B2 | 11/2016 | Shum et al.                 |
| 8,820,985 B1 | 9/2014  | Tam et al.             | D776,324 S   | 1/2017  | Gierl et al.                |
| 8,833,013 B2 | 9/2014  | Harman                 | D777,967 S   | 1/2017  | Redfern                     |
| 8,845,144 B1 | 9/2014  | Davies et al.          | 9,534,751 B2 | 1/2017  | Maglica et al.              |
| D714,989 S   | 10/2014 | Rowlette et al.        | D778,241 S   | 2/2017  | Holbrook et al.             |
| 8,870,426 B2 | 10/2014 | Biebl et al.           | D778,484 S   | 2/2017  | Guzzini                     |
| 8,888,332 B2 | 11/2014 | Martis et al.          | D778,487 S * | 2/2017  | Salomon ..... D26/138       |
| 8,890,414 B2 | 11/2014 | Rowlette et al.        | D779,100 S   | 2/2017  | Redfern                     |
| D721,845 S   | 1/2015  | Lui et al.             | D779,105 S * | 2/2017  | Krueckeberg ..... D26/89    |
| 8,926,133 B2 | 1/2015  | Booth                  | D779,711 S * | 2/2017  | Salomon ..... D26/138       |
| 8,939,418 B2 | 1/2015  | Green et al.           | 9,581,302 B2 | 2/2017  | Danesh                      |
| D722,296 S   | 2/2015  | Taylor                 | 9,599,315 B1 | 3/2017  | Harpenau et al.             |
| D722,977 S   | 2/2015  | Hagarty                | 9,605,842 B1 | 3/2017  | Davis                       |
| D722,978 S   | 2/2015  | Hagarty                | 9,605,910 B2 | 3/2017  | Swedberg et al.             |
| 8,950,898 B2 | 2/2015  | Catalano               | D785,228 S   | 4/2017  | Guzzini                     |
| D723,781 S   | 3/2015  | Miner                  | D785,852 S * | 5/2017  | Rashidi Doust ..... D26/138 |
| D723,783 S   | 3/2015  | Miner                  | D786,472 S   | 5/2017  | Redfern                     |
| D725,359 S   | 3/2015  | Miner                  | D786,474 S   | 5/2017  | Fujisawa                    |
| 8,967,575 B1 | 3/2015  | Gretz                  | D788,330 S   | 5/2017  | Johnson et al.              |
| D726,363 S   | 4/2015  | Danesh                 | D790,102 S   | 6/2017  | Guzzini                     |
| D726,949 S   | 4/2015  | Redfern                | 9,673,597 B2 | 6/2017  | Lee                         |
| 9,004,435 B2 | 4/2015  | Wronski                | 9,689,541 B2 | 6/2017  | Wronski                     |
| 9,039,254 B2 | 5/2015  | Danesh                 | D791,709 S   | 7/2017  | Holton                      |
| D731,689 S   | 6/2015  | Bernard et al.         | D791,711 S   | 7/2017  | Holton                      |
| 9,062,866 B1 | 6/2015  | Christ et al.          | D791,712 S   | 7/2017  | Holton                      |
| 9,065,264 B2 | 6/2015  | Cooper et al.          | 9,696,021 B2 | 7/2017  | Wronski                     |
| 9,068,719 B2 | 6/2015  | Van De Ven et al.      | 9,702,516 B1 | 7/2017  | Vasquez et al.              |
| 9,068,722 B2 | 6/2015  | Wronski et al.         | D795,820 S   | 8/2017  | Wengreen                    |
| D734,525 S   | 7/2015  | Gordin et al.          | 9,732,904 B1 | 8/2017  | Wronski                     |
| D735,012 S   | 7/2015  | Cowie                  | 9,739,464 B2 | 8/2017  | Wronski et al.              |
| D735,142 S   | 7/2015  | Hagarty                | D799,105 S   | 10/2017 | Eder et al.                 |
| 9,078,299 B2 | 7/2015  | Ashdown                | D800,957 S   | 10/2017 | Eder et al.                 |
| D735,933 S * | 8/2015  | Campagna ..... D26/142 | 9,791,111 B1 | 10/2017 | Huang et al.                |
| 9,109,760 B2 | 8/2015  | Shum et al.            | 9,797,562 B2 | 10/2017 | Dabiet et al.               |
| D739,355 S   | 9/2015  | D'Aubeterre            | 9,803,839 B2 | 10/2017 | Visser et al.               |
| D739,590 S   | 9/2015  | Redfern                | D805,660 S   | 12/2017 | Creasman et al.             |
| 9,140,441 B2 | 9/2015  | Goelz et al.           | D809,176 S   | 1/2018  | Partington                  |
| 9,151,457 B2 | 10/2015 | Pickard et al.         | 9,860,961 B2 | 1/2018  | Chemel et al.               |
| 9,151,477 B2 | 10/2015 | Pickard et al.         | 9,863,619 B2 | 1/2018  | Mak                         |
| D742,325 S   | 11/2015 | Leung                  | D809,465 S   | 2/2018  | Keirstead                   |
|              |         |                        | 9,964,266 B2 | 5/2018  | Danesh                      |
|              |         |                        | D820,494 S   | 6/2018  | Cohen                       |
|              |         |                        | D821,615 S   | 6/2018  | Trice                       |
|              |         |                        | D821,627 S   | 6/2018  | Ko                          |



(56)

## References Cited

## U.S. PATENT DOCUMENTS

2014/0049957 A1 2/2014 Goelz et al.  
 2014/0063776 A1 3/2014 Clark et al.  
 2014/0063818 A1 3/2014 Randolph et al.  
 2014/0071679 A1 3/2014 Booth  
 2014/0071687 A1 3/2014 Tickner et al.  
 2014/0140490 A1 5/2014 Roberts et al.  
 2014/0233246 A1 8/2014 Lafreniere et al.  
 2014/0254177 A1 9/2014 Danesh  
 2014/0268836 A1 9/2014 Thompson  
 2014/0268869 A1 9/2014 Blessitt et al.  
 2014/0299730 A1 10/2014 Green et al.  
 2014/0313775 A1 10/2014 Myers et al.  
 2014/0321122 A1 10/2014 Domagala et al.  
 2014/0347848 A1 11/2014 Pisavadia et al.  
 2015/0009676 A1 1/2015 Danesh  
 2015/0029732 A1 1/2015 Hatch  
 2015/0078008 A1 3/2015 Wang  
 2015/0138779 A1 5/2015 Livesay et al.  
 2015/0176823 A1 6/2015 Leshniak et al.  
 2015/0184837 A1 7/2015 Zhang et al.  
 2015/0198324 A1 7/2015 O'Brien et al.  
 2015/0204491 A1 7/2015 Yuan et al.  
 2015/0219317 A1 8/2015 Littman et al.  
 2015/0233556 A1 8/2015 Danesh  
 2015/0241039 A1 8/2015 Fryzek  
 2015/0263497 A1 9/2015 Korcz et al.  
 2015/0276185 A1 10/2015 Bailey et al.  
 2015/0308662 A1 10/2015 Vice et al.  
 2015/0345761 A1 12/2015 Lawlor  
 2015/0362159 A1 12/2015 Ludyjan  
 2016/0084488 A1 3/2016 Wu et al.  
 2016/0209007 A1 7/2016 Belmonte et al.  
 2016/0238225 A1 8/2016 Doust  
 2016/0308342 A1 10/2016 Witherbee et al.  
 2016/0312987 A1 10/2016 Danesh  
 2016/0348860 A1 12/2016 Bailey  
 2016/0348861 A1 12/2016 Bailey et al.  
 2016/0366738 A1 12/2016 Boulanger et al.  
 2017/0003007 A1 1/2017 Wronski  
 2017/0005460 A1 1/2017 Lee  
 2017/0045213 A1 2/2017 Williams et al.  
 2017/0059135 A1 3/2017 Jones  
 2017/0138576 A1 5/2017 Peng et al.  
 2017/0138581 A1 5/2017 Rashidi Doust  
 2017/0167672 A1 6/2017 Stauner et al.  
 2017/0167699 A1 6/2017 Schubert et al.  
 2017/0198896 A1 7/2017 May  
 2017/0307188 A1 10/2017 Oudina et al.  
 2018/0112857 A1 4/2018 Wronski et al.  
 2018/0216809 A1 8/2018 Cohen  
 2018/0224095 A1 8/2018 Cohen  
 2018/0231197 A1 8/2018 Danesh  
 2018/0283677 A1 10/2018 Cohen  
 2018/0372284 A1 12/2018 Danesh et al.  
 2019/0032874 A1 1/2019 Bonnetto et al.  
 2019/0049080 A1 2/2019 Danesh  
 2019/0063701 A1 2/2019 Lotfi et al.  
 2019/0093836 A1 3/2019 Danesh  
 2020/0182420 A1 6/2020 Cohen et al.

## FOREIGN PATENT DOCUMENTS

CA 2561459 A1 3/2007  
 CA 2691480 C 5/2011  
 CA 2734369 A1 9/2011  
 CA 2815067 A1 11/2013  
 CA 2848289 5/2014  
 CN 2182475 Y 11/1994  
 CN 201059503 Y 5/2008  
 CN 201259125 Y 6/2009  
 CN 101608781 12/2009  
 CN 201636626 U 11/2010  
 CN 102062373 5/2011  
 CN 202014067 U 10/2011  
 CN 202392473 U 8/2012

CN 202733693 2/2013  
 CN 103307518 9/2013  
 CN 103322476 A 9/2013  
 CN 203202661 U 9/2013  
 CN 203215483 U 9/2013  
 CN 101498411 B 11/2013  
 CN 203273663 U 11/2013  
 CN 203297980 U 11/2013  
 CN 203628464 U 6/2014  
 CN 203641919 6/2014  
 CN 204300818 4/2015  
 CN 104654142 A 5/2015  
 CN 204513161 7/2015  
 CN 204611541 9/2015  
 CN 204786225 11/2015  
 CN 204829578 12/2015  
 CN 103712135 B 4/2016  
 CN 205606362 9/2016  
 CN 206130742 4/2017  
 CN 103154606 B 5/2017  
 CN 206222112 6/2017  
 CN 107013845 A 8/2017  
 CN 107084343 A 8/2017  
 DE 9109828 2/1992  
 DE 19947208 5/2001  
 EP 1 589 289 10/2005  
 EP 1 672 155 A1 6/2006  
 EP 1688663 8/2006  
 EP 2 095 938 A1 2/2008  
 EP 2 306 072 A1 4/2011  
 EP 2 453 169 A2 5/2012  
 EP 2 193 309 B1 7/2012  
 EP 2 735 787 5/2014  
 EP 3 104 024 A1 12/2016  
 GB 2325728 12/1998  
 GB 2 427 020 12/2006  
 GB 2466875 7/2010  
 GB 2471929 1/2014  
 GB 2 509 772 7/2014  
 JP 2007-091052 4/2007  
 JP 2007-265961 10/2007  
 JP H02-113002 10/2007  
 JP 2011-060450 A2 3/2011  
 JP 2012-064551 A 3/2012  
 JP 2015-002027 A2 1/2015  
 JP 2015-002028 A2 1/2015  
 JP 2016219335 A 12/2016  
 JP 2017-107699 A2 6/2017  
 KR 1020110008796 A 1/2011  
 KR 1020120061625 A 6/2012  
 MX 2011002947 A 9/2011  
 TW 474382 U 1/2002  
 WO WO-2013/128896 A1 9/2013  
 WO WO 2014/015656 1/2014  
 WO WO-2015/000212 A1 1/2015  
 WO WO-2016/152166 A1 9/2016

## OTHER PUBLICATIONS

Maxim Lighting International, "Wafer LED Product Brochure", undated, 2 pages.  
 Maxim Lighting International, "Convert LED Flush Mount", undated.  
 Maxim Lighting International, "Views of the Wafer Flush Mount", undated.  
 Maxim Lighting International, "Product/Drawing Specification Sheet", undated.  
 "Advanced LED Solutions," Imtra Marine Lighting. 2011. 39 pages.  
 "Cree LMH2 LED Module with TrueWhite Technology," Cree Product Family Data Sheet. 2011. 3 pages.  
 "Cree LMH2 LED Modules Design Guide," Cree Product Design Guide. 2011. 20 pages.  
 "Cree LMH2 LED Modules," Mouser Electronics. 2 pages.  
 "LED Undercabinet Pocket Guide," ELCO Lighting. 12 pages.  
 "Membrane Penetrations in Fire-Resistance Rated Walls," [https://www.ul.com/wp-content/uploads/2014/04/ul\\_MembranePenetrations.pdf](https://www.ul.com/wp-content/uploads/2014/04/ul_MembranePenetrations.pdf), Issue 1, 2009, 2 pages.

(56)

**References Cited**

## OTHER PUBLICATIONS

“Metallic and Non-metallic Outlet Boxes Used in Fire-rated Assembly,” <https://iaeimagazine.org/magazine/2000/09/16/metallic-and-non-metallic-outlet-boxes-used-in-fire-rated-assembly/>, Sep. 16, 2000, 5 pages.

“Metallic Outlet Boxes,” UL 514A, Underwriters Laboratories, Inc., Feb. 16, 2004 (Title Page Reprinted Aug. 10, 2007), 106 pages.

“Outlet Boxes for Use in Fire Rated Assemblies,” [https://www.ul.com/wp-content/uploads/2014/04/UI\\_outletboxes.pdf](https://www.ul.com/wp-content/uploads/2014/04/UI_outletboxes.pdf), 2011, 2 pages.

“Portland Bi-Color, Warm White/Red,” item:ILIM30941.imtra Marine Products. 2012. 3 pages.

“Undercabinet Pucks, Xyris Mini LED Puck Light,” ELCO Lighting. Sep. 2018. 1 page.

“VERSI LED Mini Flush,” Lithonia Lighting. 6 pages.

2006 International Building Code, Section 712 Penetrations, 2006, 4 pages.

4" Octagon Concrete Boxes and Back Plates. Appleton. Accessed at [www.appletonelec.com](http://www.appletonelec.com) on May 6, 2019. 1 page.

Acrich COB Zhaga Module, Product Description, Seoul Semiconductor, Nov. 2016, 39 pages.

Be seen in the best light. Lightolier by signify. Comprehensive 2019 Lighting Catalog. 114 pages.

Bortz, J. C. et al., “Optimal design of a nonimaging TIR doublet lens for an illumination system using an LED source”, Proc. SPIE 5529, Nonimaging Optics and Efficient Illumination Systems, (Sep. 29, 2004); doi: 10.1117/12.562598; <https://doi.org/10.1117/12.562598>, 10 pages.

BXUV.GuideInfo, Fire Resistance Ratings—ANSI/UL 263, UL Online Certifications Directory, last updated Nov. 3, 2016, 27 pages. Canadian Office Action dated Aug. 11, 2017 from Canadian Application No. 2,941,051, 4 pages.

Canadian Office Action dated Dec. 23, 2013 from Canadian Application No. 2,778,581, 3 pages.

Canadian Office Action dated Dec. 6, 2016 from Canadian Application No. 2,879,629, 3 pages.

Canadian Office Action dated Feb. 1, 2016 from Canadian Application No. 2,879,486, 5 pages.

Canadian Office Action dated Jun. 12, 2017 from Canadian Application No. 2,927,601, 4 pages.

Canadian Office Action dated Mar. 22, 2016 from Canadian Application No. 2,879,629, 4 pages.

Canadian Office Action dated Mar. 9, 2017 from Canadian Application No. 2,931,588, 5 pages.

Carlson? Zip Box? Blue™ Switch and Outlet Boxes, Product Brochure, <http://www.carlonsales.com/brochures.php>, 2006, 22 pages.

CEYY. GuideInfo, Outlet Boxes and Fittings Certified for Fire Resistance, UL Online Certifications Director, last updated May 16, 2013, 2 pages.

Civil Action No. 2:18-cv-07090. Complaint for Infringement and Unfair Competition. *DMF, Inc. v. AMP Plus, Inc. d/b/a ELCO Lighting*. 52 pages. Dated Aug. 15, 2018.

Cooper Lighting Halo ML56 LED System Product Sheet. Mar. 2, 2015. Accessed at [http://www.cooperindustries.com/content/dam/public/lighting/products/documents/halo/spec\\_sheets/halo-ml56600-80cri-141689-sss.pdf](http://www.cooperindustries.com/content/dam/public/lighting/products/documents/halo/spec_sheets/halo-ml56600-80cri-141689-sss.pdf). 8 pages.

Cree LED Lamp Family Sales Sheet—Better light is beautiful light , Apr. 24, 2017, 2 pages.

CS&E PCT Collaborative Search and Examination Pilot Upload Peer Contribution in International Patent Application No. PCT/US18/62868 dated Mar. 14, 2019, 61 pages.

CS&E PCT Collaborative Search and Examination Pilot Upload Peer Contribution in International Patent Application No. PCT/US18/67614 dated Apr. 24, 2019, 53 pages.

Delhi Rehab & Nursing Facility ELM16-70884. Vertex Innovative Solutions Feb. 25, 2016. 89 pages.

DME Series Installation Instructions, Oct. 18, 2011, 2 pages.

DMF, Inc., “dmfLIGHTING: LED Recessed Downlighting,” DRD2 Product Brochure, Oct. 23, 2014, 50 pages.

DMF, Inc., “dmfLIGHTING: LED Recessed Downlighting,” Product Catalog, Aug. 2012, 68 pages.

DMF, Inc., “dmfLIGHTING: LED Recessed Lighting Solutions,” Info sheets, Mar. 15, 2012, 4 pages.

Dross, O. et al., “Review of SMS design methods and real-world applications”, Proc. SPIE 5529, Nonimaging Optics and Efficient Illumination Systems, (Sep. 29, 2004); doi: 10.1117/12.561336; <https://doi.org/10.1117/12.561336>, 14 pages.

Final Office Action dated Apr. 2, 2015 from U.S. Appl. No. 13/484,901, 13 pages.

Final Office Action dated Apr. 27, 2016 from U.S. Appl. No. 14/184,601, 19 pages.

Final Office Action dated Jul. 26, 2017 from U.S. Appl. No. 14/184,601, 18 pages.

Final Office Action dated Jun. 23, 2016 from U.S. Appl. No. 13/484,901, 18 pages.

Final Office Action dated Jun. 6, 2019 from U.S. Appl. No. 15/688,266, 7 pages.

Final Office Action dated Mar. 15, 2019 from U.S. Appl. No. 15/132,875, 15 pages.

Halo, H7 LED Downlight Trims 49x Series, 6-inch LED Trims for Use with M17x LED Modules, Cooper Lighting, ADV110422, rev. Aug. 12, 2011, 15 pages.

Halo, Halo LED H4 H7 Collection, SustainabLEDesign, Cooper Lighting, (emphasis on p. 18 “H7 Collection LED Modules—Halo LED H7 Module Features,”) Mar. 28, 2012, 52 pages.

Halo, LED Module ML706x, Cooper Lighting, General Installation for All Modules/p. 1; Tether Installation/pp. 2-3; Installation into Halo H750x Series LED—only (Non-Screw Based), Recessed Fixture, p. 4, Oct. 20, 2009, 4 pages.

<https://www.zhagastandard.org/books/book18/>, Mar. 2017, 5 pages.

IC1JB Housing 4" IC-Rated New Construction Junction Box Housing. AcuityBrands. Accessed at <https://www.acuitybrands.com/en/products/detail/845886/juno/ic1jb-housing/4-ic-rated-new-construction-junction-box-housing> on Jun. 27, 2019.

Imtra Marine Lighting 2008 Catalog. 40 pages.

Imtra Marine Lighting 2009 Catalog. 32 pages.

Imtra Marine Lighting Spring 2007 Catalog. 36 pages.

International Search Report and Written Opinion in International Patent Application No. PCT/US18/39048 dated Dec. 14, 2018. 24 pages.

International Search Report and Written Opinion in International Patent Application No. PCT/US18/62868 dated Mar. 14, 2019, 13 pages.

International Search Report and Written Opinion in International Patent Application No. PCT/US18/67614 dated Apr. 25, 2019, 20 pages.

International Search Report and Written Opinion in International Patent Application No. PCT/US19/32281 dated Aug. 2, 2019, 18 pages.

International Search Report and Written Opinion in PCT/US2018/048357 dated Nov. 14, 2018, 13 pages.

KWIK?BRACE? ? New Construction Braces for Lighting Fixtures or Ceiling Fans 1-½ in. Depth. Hubbel. Accessed at <https://hubbellcdn.com/specsheet/926.pdf> on Jun. 27, 2019. 1 pages.

Medvedev, V. et al., “Uniform LED illuminator for miniature displays,” Proc. SPIE 3428, Illumination and Source Engineering, (Oct. 20, 1998); doi: 10.1117/12.327957; <https://doi.org/10.1117/12.327957>, 13 pages.

Non-Final Office Action dated Apr. 12, 2018 tor U.S. Appl. No. 29/638,259, 5 pages.

Non-Final Office Action dated Apr. 30, 2010 from U.S. Appl. No. 12/173,232, 13 pages.

Non-Final Office Action dated Dec. 15, 2016 from U.S. Appl. No. 14/184,601, 18 pages.

Non-Final Office Action dated Dec. 5, 2018 from U.S. Appl. No. 14/942,937, 13 pages.

Non-Final Office Action dated Feb. 7, 2019 from U.S. Appl. No. 16/200,393, 32 pages.

Non-Final Office Action dated Feb. 6, 2018 from U.S. Appl. No. 15/167,682, 9 pages.

Non-Final Office Action dated Jun. 11, 2019 from U.S. Appl. No. 15/901,738, 6 pages.

Non-Final Office Action dated Jun. 2, 2015 from U.S. Appl. No. 14/183,424, 20 pages.

(56)

## References Cited

## OTHER PUBLICATIONS

- Non-Final Office Action dated Jun. 25, 2018 for U.S. Appl. No. 29/541,565, 10 pages.
- Non-Final Office Action dated Mar. 15, 2010 from U.S. Appl. No. 12/100,148, 8 pages.
- Non-Final Office Action dated May 16, 2018 for U.S. Appl. No. 15/132,875, 18 pages.
- Non-Final Office Action dated May 17, 2017 from U.S. Appl. No. 14/183,424, 20 pages.
- Non-Final Office Action dated Oct. 16, 2014 from U.S. Appl. No. 13/484,901, 11 pages.
- Non-Final Office Action dated Oct. 24, 2018 for U.S. Appl. No. 15/688,266, 14 pages.
- Non-Final Office Action dated Sep. 15, 2015 from U.S. Appl. No. 13/484,901, 16 pages.
- Non-Final Office Action dated Sep. 5, 2014 from U.S. Appl. No. 13/791,087, 8 pages.
- Non-Final Office Action dated Sep. 6, 2017 from U.S. Appl. No. 14/726,064, 8 pages.
- Notice of Allowance dated Apr. 1, 2019 from U.S. Appl. No. 15/167,682, 7 pages.
- Notice of Allowance dated Apr. 8, 2019 from U.S. Appl. No. 29/653,142, 8 pages.
- Notice of Allowance dated Aug. 23, 2017 from Canadian Application No. 2,879,629, 1 page.
- Notice of Allowance dated Feb. 8, 2019 from U.S. Appl. No. 29/541,565, 5 pages.
- Notice of Allowance dated Jan. 16, 2015 from U.S. Appl. No. 29/467,026, 9 pages.
- Notice of Allowance dated Jan. 2, 2019 from U.S. Appl. No. 29/541,565, 6 pages.
- Notice of Allowance dated Jan. 30, 2015 from U.S. Appl. No. 13/791,087, 9 pages.
- Notice of Allowance dated Jul. 31, 2019 from U.S. Appl. No. 15/167,682, 7 pages.
- Notice of Allowance dated Jun. 12, 2019 from U.S. Appl. No. 16/016,040, 8 pages.
- Notice of Allowance dated Mar. 24, 2016 from U.S. Appl. No. 14/247,149, 8 pages.
- Notice of Allowance dated Mar. 26, 2018 for U.S. Appl. No. 14/184,601, 10 pages.
- Notice of Allowance dated May 10, 2018 from U.S. Appl. No. 14/726,064, 7 pages.
- Notice of Allowance dated May 22, 2018 from U.S. Appl. No. 14/183,424, 9 pages.
- Notice of Allowance dated Nov. 27, 2018 from U.S. Appl. No. 15/167,682, 11 pages.
- Notice of Allowance dated Oct. 21, 2016 from U.S. Appl. No. 13/484,901, 7 pages.
- Notice of Allowance dated Oct. 4, 2018 from U.S. Appl. No. 15/947,065, 9 pages.
- Notice of Allowance dated Oct. 9, 2018 from U.S. Appl. No. 29/653,142, 7 pages.
- Notice of Allowance dated Sep. 19, 2018 from U.S. Appl. No. 15/167,682, 7 pages.
- Notice of Allowance dated Sep. 19, 2019 from U.S. Appl. No. 16/016,040, 7 pages.
- Notice of Allowance dated Sep. 21, 2018 from U.S. Appl. No. 29/645,941, 5 pages.
- OneFrame Recessed LED Downlight. Dmflighting.com. Published Jun. 6, 2018. Retrieved at <https://www.dmflighting.com/product/oneframe> on Jun. 6, 2018. 11 pages.
- RACO 4 in. Octagon Welded Concrete Ring, 3-1/2 in. Deep with 1/2 and 3/4 in. Knockouts and includes 890 cover (20-Pack). Model # 280. Accessed at <https://www.homedepot.com/p/RACO-4-in-Octagon-Welded-Concrete-Ring-3-1-2-in-Deep-with-1-2-and-3-4-in-Knockouts-and-cludes-890-cover-20-Pack-280/203638679> on Jan. 18, 2019. 3 pages.
- RACO 4 in. Octagon Welded Concrete Ring, 6 in. Deep with 1/2 and 3/4 in. Knockouts (10-Pack). Model # 276. Accessed at <https://www.homedepot.com/p/RACO-4-in-Octagon-Welded-Concrete-Ring-6-in-Deep-with-1-2-and-3-4-in-Knockouts-10-Pack-276/203638675> on Jan. 16, 2019. 4 pages.
- RACO Commercial, Industrial and Residential Electrical Products. Hubbell. Accessed at [www.Hubbell-RTB.com](http://www.Hubbell-RTB.com) on May 6, 2019. 356 pages.
- SlimSurface surface mount downlighting. Philips Lightolier 2018. 8 pages.
- Specification & Features 4" Octagonal Concrete Box Covers. Orbit Industries, Inc. Accessed at <https://www.orbitelectric.com> on May 6, 2019. 1 page.
- Supplemental Notice of Allowance dated Aug. 5, 2019 from U.S. Appl. No. 15/947,065, 2 pages.
- U.S. Appl. No. 14/713,340, Oct. 23, 1923, Knight.
- Final Office Action dated Jan. 29, 2016 from U.S. Appl. No. 14/183,424, 21 pages.
- Non-Final Office Action dated Jul. 20, 2015 from U.S. Appl. No. 14/184,601, 16 pages.
- Parkyn, W. A. et al., "New TIR lens applications for light-emitting diodes", Proc. SPIE 3139, Nonimaging Optics: Maximum Efficiency Light Transfer IV, (Oct. 3, 1997); doi: 10.1117/12.290217, 7 pages.
- Schreiber, P. et al., "Microoptics for homogeneous LED-illumination", Proc. SPIE 6196, Photonics in Multimedia, 61960P (Apr. 21, 2006); doi: 10.1117/12.663084; <https://doi.org/10.1117/12.663084>, 11 pages.
- Van Giel, B. V. et al., "Design of axisymmetrical tailored concentrators for LED light source applications", Proc. SPIE 6196, Photonics in Multimedia, 619603 (Apr. 21, 2006); doi: 10.1117/12.660115; <https://doi.org/10.1117/12.660115>, 11 pages.
- Zhen, Y. et al., "The optimal design of TIR lens for improving LED illumination uniformity and efficiency", Proc. SPIE 6834, Optical Design and Testing III, 68342K (Nov. 28, 2007); doi: 10.1117/12.756101, 9 pages.
- Zou, H. et al., "58.1: Single-Panel LCOS Color Projector with LED Light Sources", SID Symposium, vol. 36, Issue 1, 4 pages (May 2005).
- Notice of Allowance dated Jan. 28, 2019 from U.S. Appl. No. 29/664,471, 8 pages.
- Non-Final Office Action dated Jul. 24, 2018 from U.S. Appl. No. 29/638,259, 5 pages.
- Non-Final Office Action dated Apr. 4, 2019 from U.S. Appl. No. 29/678,482, 8 pages.
- Notice of Allowance dated Apr. 17, 2019 from U.S. Appl. No. 29/678,478, 7 pages.
- Ex-Parte Quayle Action dated Jun. 27, 2019 from U.S. Appl. No. 29/683,730, 5 pages.
- Notice of Allowance dated Sep. 11, 2019 from U.S. Appl. No. 29/653,142, 6 pages.
- Corrected Notice of Allowance dated Sep. 27, 2019 from U.S. Appl. No. 15/167,682, 2 pages.
- Final Office Action dated Sep. 27, 2019 from U.S. Appl. No. 16/200,393, 34 pages.
- Notice of Allowance dated Feb. 15, 2019 from U.S. Appl. No. 15/947,065, 9 pages.
- Notice of Allowance dated Oct. 1, 2019 from U.S. Appl. No. 14/942,937, 7 pages.
- Final Office Action dated Oct. 3, 2019 from U.S. Appl. No. 29/678,482, 6 pages.
- Corrected Notice of Allowance dated Oct. 10, 2019 from U.S. Appl. No. 16/016,040, 2 pages.
- Cree® LMR2 LED Module. Product Family Data Sheet Cree 2011. 3 pages.
- Notice of Allowance dated Oct. 16, 2019 from U.S. Appl. No. 15/132,875, 12 pages.
- International Search Report and Written Opinion in International Patent Application No. PCT/US2019/036477 dated Oct. 17, 2019, 5 pages.
- ML56 LED Lighting System 600/900/1200 Series Halo. Cooper Lighting Brochure 2015. Accessed at <https://images.homedepot-static.com/catalog/pdfImages/06/06d28f93-4bf6-45be-a35a-a0239606f227.pdf>. 41 pages.



(56)

**References Cited**

## OTHER PUBLICATIONS

Switch and Outlet Boxes and Covers Brochure. Appelton 2010. 77 pages.

Non-Final Office Action dated Dec. 30, 2019 from U.S. Appl. No. 16/653,497, 8 pages.

Notice of Allowance dated Feb. 5, 2020 from U.S. Appl. No. 15/901,738, 8 pages.

Notice of Allowance dated Feb. 5, 2020 from U.S. Appl. No. 29/678,482, 13 pages.

Maxim Convert Fixture. LMXCAT1805 Maxim Main Catalog 2018 p. 639.

Maxim Wafer. LMXCAT1805 Maxim Main Catalog 2018 pp. 636-638.

Maxim Lighting Trim Trifold LMXBRO1905 2019. Accessed at <https://www.maximlighting.com/Upload/download/brochure/pdf/LMXBRO1905.pdf> on Feb. 13, 2020. 2 pages.

International Search Report and Written Opinion in International Patent Application No. PCT/US2019/054220 dated Feb. 24, 2020, 23 pages.

Final Office Action dated Mar. 17, 2020 for U.S. Appl. No. 29/653,142, 13 pages.

LED Book Price Guide 2012. DMF Light. Issued Jun. 26, 2013. 3 pages.

DLER411 4" Recessed LED Retrofit Module. DMF Light. Issued Jun. 15, 2011. 1 page.

DLEI411 4" Recessed LED New Construction, IC. DMF Light. Issued Nov. 30, 2011. 1 page.

DLEIR411 4" Recessed LED Remodel, IC. DMF Light. Issued Jun. 15, 2011. 1 page.

3 & 4" DLE Series LED Sample Case Now Available. DMF Light. Issued Jan. 6, 2012. 1 page.

DLEI3 3" Recessed LED New Construction, IC. DMF Light. Issued Nov. 30, 2011. 2 pages.

Ridgway-Barnes, SlimSurface LED Downlight: One of the thinnest LED surface mount downlights in the market. Philips Lighting Blog. Oct. 28, 2014. Accessed at <http://applications.nam.lighting.philips.com/blog/index.php/2014/10/28/slimsurface-led-downlight-one-of-the-thinnest-led-surface-mount-downlights-in-the-market/>. 3 pages.

SlimSurface LED S5R, S7R & S10R Round 5", 7" and 10" Apertures. Lightolier by Signify. Nov. 2018. 9 pages.

Non-Final Office Action dated Apr. 2, 2020 for U.S. Appl. No. 16/522,275, 21 pages.

Innofit 8" Commercial Downlight. Greencreative. Accessed at <https://greencreative.com/products/luminaires/commercial-downlighting/innofit-cdl-8-inch-12-19-27w/> on Apr. 28, 2020. 6 pages.

20 cu. in. Blue Polycarbonate Round New Work Ceiling Electrical Box. Carlon. Accessed at <https://www.homedepot.com/p/Carlon-20-cu-in-Blue-Polycarbonate-Round-New-Work-Ceiling-Electrical-Box-B520P-UPC/202592617?MERCHANT=REC--pipsem--100404124--202592617--N> on May 15, 2020. 14 pages.

Notice of Allowance dated May 18, 2020 from U.S. Appl. No. 15/901,738, 7 pages.

Non-Final Office Action dated May 20, 2020 for U.S. Appl. No. 15/688,266, 6 pages.

Non-Final Office Action dated May 26, 2020 for U.S. Appl. No. 16/719,361, 10 pages.

International Search Report and Written Opinion in PCT/US2020/017331 dated Jun. 22, 2020, 16 pages.

Taiwan Office Action and translation thereof dated Jun. 12, 2020 from Taiwan Application No. 108116564, 8 pages.

Access Lighting Installation Instructions. No. 20870LEDD/20871LEDD/20872LEDD. Dec. 16, 2019. 2 pages.

Model No. :: 20870LEDD-WH/ACR Infinite Specification Sheet. Access Lighting. Apr. 9, 2020. 1 page.

Petition for Inter Partes Review of U.S. Pat. No. 9,964,266 Pursuant to 37 C.F.R. § 42.100 et seq. *AMP Plus Inc. dbd Elco Lighting v. DMF, Inc.*, IPR2019-01094 filed May 17, 2019. 108 pages.

IPR2019-01094 Exhibit 1001. U.S. Pat. No. 9,964,266 ("the 266 Patent"). 14 pages.

IPR2019-01094 Exhibit 1002. Declaration of Eric Bretschneider, Ph.D. ("Bretschneider"). 107 pages.

IPR2019-01094 Exhibit 1003. Curriculum Vitae of Dr. Bretschneider. 11 pages.

IPR2019-01094 Exhibit 1004. Excerpts from the File History of U.S. Pat. No. 9,964,266. 105 pages.

IPR2019-01094 Exhibit 1005. Imtra 2011 Marine Lighting Catalog—Advanced LED Solutions ("Imtra 2011"). 40 pages.

IPR2019-01094 Exhibit 1006. Imtra 2007 Marine Lighting Catalog ("Imtra 2007"). 36 pages.

IPR2019-01094 Exhibit 1007. U.S. Pat. No. 9,366,418 ("Gifford"). 9 pages.

IPR2019-01094 Exhibit 1008. Declaration of Colby Chevalier ("Chevalier"). 89 pages.

IPR2019-01094 Exhibit 1009. U.S. Pat. No. 7,102,172 ("Lynch"). 41 pages.

IPR2019-01094 Exhibit 1010. Illuminating Engineering Society, ANSI RP-16-10, Nomenclature and Definitions for Illuminating Engineering (approved as an American National Standard Jul. 15, 2005, approved by the IES Board of Directors Oct. 15, 2005). 4 pages.

IPR2019-01094 Exhibit 1011. Underwriters Laboratories Inc. Standard for Safety, Standard UL-8750, entitled Light Emitting Diode (LED) Equipment for Use in Lighting (1st ed. 2009). 5 pages.

IPR2019-01094 Exhibit 1012. Celanese CoolPoly® D5502 Thermally Conductive Liquid Crystalline Polymer Specification ("CoolPoly"). 1 page.

IPR2019-01094 Exhibit 1013. Illuminating Engineering Society of North America, IES Lighting Handbook (John E. Kaufman and Howard Haynes eds., Application vol. 1981) ("Lighting Handbook"). 5 pages.

IPR2019-01094 Exhibit 1014. California Energy Commission, PIER Lighting Research Program: Project 2.3 Low-profile LED Luminaires Final Report (Prepared by Lighting Research Center, Jan. 2005) ("Pier LRP"). 70 pages.

IPR2019-01094 Exhibit 1015. Jim Sinopoli, Using DC Power to Save Energy and End the War on Currents, GreenBiz (Nov. 15, 2012), <https://www.greenbiz.com/news/2012/11/15/using-dc-power-save-energy-end-war-currents> ("Sinopoli"). 6 pages.

IPR2019-01094 Exhibit 1016. Robert W. Johnson, "Thought Leadership White Paper: AC Versus DC Power Distribution" (Nov. 2012) ("Johnson"). 10 pages.

IPR2019-01094 Exhibit 1017. Lumileds, Luxeon Rebel General Purpose Product Datasheet, Specification DS64 (2016) ("Luxeon Rebel"). 26 pages.

IPR2019-01094 Exhibit 1018. U.S. Pat. No. 8,454,204 ("Chang"). 11 pages.

IPR2019-01094 Exhibit 1019. U.S. Department of Energy, CALiPER Benchmark Report: Performance of Incandescent A-Type and Decorative Lamps and LED Replacements (prepared by Pacific National Laboratory, Nov. 2008) ("CALiPER 2008"). 25 pages.

IPR2019-01094 Exhibit 1020. U.S. Pat. No. 3,836,766 ("Auerbach"). 13 pages.

IPR2019-01094 Exhibit 1021. U.S. Department of Energy, CALiPER Application Summary Report 16: LED BR30 and R30 Lamps (prepared by Pacific Northwest National Laboratory, Jul. 2012) ("CALiPER 2012"). 26 pages.

IPR2019-01094 Exhibit 1022. Sandia National Laboratories, Sandia Report: "The Case for a National Research Program on Semiconductor Lighting" (Jul. 2000) ("Haitz"). 24 pages.

IPR2019-01094 Exhibit 1023. Sylvania, Post Top Street Light LED Retrofit Kit Specification, LED40POST (2009) ("Sylvania"). 4 pages.

IPR2019-01094 Exhibit 1024. Webster's New Collegiate Dictionary (1973) ("Webster's"). 2 pages.

IPR2019-01094 Exhibit 1025. 3M Wire Connectors and Tools Catalog 2013 ("3M Catalog"). 22 pages.

IPR2019-01094 Exhibit 1026. Wakefield Semiconductor Heat Sinks and Thermal Products 1974 Catalog ("Wakefield"). 3 pages.

IPR2019-01094 Exhibit 1027. U.S. Department of Energy, Solid-State Lighting Research and Development Portfolio: Multi-Year Program Plan FY'07-FY'12 (prepared by Navigant Consulting, Inc., Mar. 2006) ("DOE 2006"). 129 pages.

(56)

**References Cited**

## OTHER PUBLICATIONS

IPR2019-01094 Exhibit 1028. U.S. Department of Energy, Solid-State Lighting Research and Development: Multi-Year Program Plan (Apr. 2013) (“DOE 2013”). 89 pages.

Declaration of Colby Chevalier from Central District of California Civil Docket for Case #: 2:18-cv-07090-CAS-GJC filed Jun. 3, 2019, signed Jun. 3, 2019. 2 pages.

Docket Listing in Inter Partes Review of U.S. Pat. No. 9,964,266. *Docket Navigator AMP Plus, Inc. d/b/a Elco Lighting et al v. DMF, Inc.* PTAB-IPR2019-01094. Downloaded Mar. 25, 2020. 4 pages.

Petition for Inter Partes Review of U.S. Pat. No. 9,964,266 Pursuant to 37 C.F.R. § 42.100 et seq. *AMP Plus Inc. dbd ELCO Lighting v. DMF, Inc.* PTAB-IPR2019-01500 filed Aug. 14, 2019. 99 pages.

Docket Listing in Inter Partes Review of U.S. Pat. No. 9,964,266. *AMP Plus, Inc. d/b/a ELCO Lighting et al v. DMF, Inc.* PTAB-IPR2019-01500. Downloaded Mar. 25, 2020. 3 pages.

Docket Listing in Civil Action No. 2:18-cv-07090. *DMF, Inc. v. AMP Plus, Inc. d/b/a ELCO Lighting et al* CDCA-2-18-cv-07090. Downloaded on Mar. 25, 2020. 39 pages.

Civil Action No. 2:19-cv-4519. Complaint for Patent Infringement. *DMF, Inc. v. AMP Plus, Inc. d/b/a ELCO Lighting*. 52 pages dated May 22, 2019. 23 pages.

Docket Listing in Civil Action No. 2:19-cv-4519. *DMF Inc v. AMP Plus, Inc. d/b/a ELCO Lighting et al* CDCA-2-19-cv-04519. Downloaded on Mar. 25, 2020. 3 pages.

Decision Denying Institution of Inter Partes Review of U.S. Pat. No. 9,964,266 in IPR2019-01500 dated Mar. 17, 2020. 21 pages.

Defendants’ Notice of Prior Art Pursuant to 35 U.S.C. § 282 in Civil Action No. 2:18-cv-07090-CAS-GJS dated Feb. 28, 2020. 7 pages.

Defendant AMP Plus, Inc.’s Opposition to DMF’s Motion for Summary Judgment in Civil Action No. 2:18-cv-07090-CAS-GJS filed Feb. 10, 2020. 32 pages.

Declaration of Eric Bretschneider, Ph.D in Support of Amp Plus, Inc.’s Opposition to Dmf, Inc.’s Motion for Partial Summary Judgment in Civil Action No. 2:18-cv-07090-CAS-GJS filed Feb. 10, 2020. 210 pages.

Plaintiff DMF’s Reply in Support of Motion for Partial Summary Judgment in Civil Action No. 2:18-cv-07090-CAS-GJS filed Feb. 18, 2020. 33 pages.

Declaration of James R. Benya in Support of Plaintiff DMF’s Motion for Summary Judgment in Civil Action No. 2:18-cv-07090-CAS-GJS filed Feb. 3, 2020. 193 pages.

Underwriters Laboratories Inc. Standard for Safely. UL 1598. Luminaires Jan. 11, 2020. 12 pages.

Exceptional LED Lighting Technology Product Portfolio. LightingScience 2012. 11 pages.

“Cree LMH2 LED Modules,” Mouser Electronics. Sep. 9, 2012. 4 pages.

Slim Line Disc. Eye LEDs Specification Sheet 2012. 2 pages.

HiBay LED Heat Sink. Wakefield-vette. Dec. 11, 2017. 1 pages.

Thermal Management of Cree® XLamp® LEDs. Cree Application Note. 2004. 19 pages.

Imtra Marine Lighting Fall 2007 Catalog. 32 pages.

Notice of Allowance dated Apr. 9, 2020 from U.S. Appl. No. 16/653,497, 7 pages.

Notice of Allowance dated Jul. 10, 2020 from U.S. Appl. No. 29/694,475, 6 pages.

Corrected Notice of Allowability dated Oct. 25, 2018 from U.S. Appl. No. 14/183,424, 3 pages.

dmf DRD2 Recessed LED Downlight General Retrofit Junction Box Dated: Dec. 18, 2015 Downloaded Jul. 28, 2018, from <https://www.alconlighting.com/specsheets/DMF/DRD2-Junction-Box-Retrofit-Spec-Sheet.pdf>, 6 pages.

dmf DRD2 Recessed LED Downlight General New Construction 4", 5", 6" Aperture Dated: Aug. 31, 2016 Downloaded Jul. 28, 2018, from [https://www.cansandfans.com/sites/default/files/DRD2-General-New-Construction-Spec-Sheet\\_7\\_0.pdf](https://www.cansandfans.com/sites/default/files/DRD2-General-New-Construction-Spec-Sheet_7_0.pdf), 9 pages.

Mar. 5, 2016—The DMF Lighting DRD2 Recessed LED Downlight General Retrofit Junction Box—Wet Location Rated is the ideal solution for Commercial LED recessed lighting retrofit applications. web cache <https://www.alconlighting.com/dmf-drd2m.html> (downloaded Jul. 28, 2018), 6 pages.

Ex Parte Quayle Office Action dated Oct. 16, 2018 for U.S. Appl. No. 29/663,037, 7 pages.

Notice of Allowance dated Nov. 19, 2018 from U.S. Appl. No. 29/663,037, 5 pages.

Notice of Allowance dated Nov. 15, 2018 from U.S. Appl. No. 29/663,040, 5 pages.

LED modules advance in performance, standardization questions persist (Magazine). LEDs Magazine. Oct. 29, 2013. Accessed at <https://www.ledsmagazine.com/leds-ssl-design/modular-light-engines/article/16695073/led-modules-advance-in-performance-standardization-questions-persist-magazine>. 9 pages.

Octagon Concrete Box Cover with (3) 1/2 in. & (2) 3/4 in. Conduit Knockouts. Garvin. Accessed at [https://www.garvinindustries.com/covers-and-device-rings/concrete-slab-box-covers-adaptor-rings/flat-covers-all-styles/cbp?gclid=Cj0KCQjw9b\\_4BRCMARIsADMUlypJc0K80UHdDTI9C5m4BDzR3U87PRYV1NdQIBFxEWQ21\\_3ofTCTqEkaAi\\_DEALw\\_wcB](https://www.garvinindustries.com/covers-and-device-rings/concrete-slab-box-covers-adaptor-rings/flat-covers-all-styles/cbp?gclid=Cj0KCQjw9b_4BRCMARIsADMUlypJc0K80UHdDTI9C5m4BDzR3U87PRYV1NdQIBFxEWQ21_3ofTCTqEkaAi_DEALw_wcB) on Jul. 20, 2020. 1 page.

Notice of Allowance dated Jul. 28, 2020 from U.S. Appl. No. 16/719,361, 8 pages.

Notice of Allowance dated Jul. 29, 2020 from U.S. Appl. No. 16/522,275, 8 pages.

Non-Final Office Action dated Aug. 19, 2020 for U.S. Appl. No. 16/886,365, 16 pages.

Notice of Allowance dated Sep. 8, 2020 from U.S. Appl. No. 29/678,482, 5 pages.

Corrected Notice of Allowance dated Sep. 11, 2020 from U.S. Appl. No. 16/719,361, 2 pages.

Canadian Office Action in Application No. 2931588 dated Aug. 13, 2020, 5 pages.

Corrected Notice of Allowance dated Sep. 14, 2020 from U.S. Appl. No. 16/522,275, 2 pages.

Notice of Allowance dated Sep. 22, 2020 from U.S. Appl. No. 29/683,730, 6 pages.

Notice of Allowance dated Sep. 22, 2020 from U.S. Appl. No. 29/653,142, 6 pages.

Request for Ex Parte Reexamination of U.S. Patent No. 10,663,127 filed Aug. 3, 2020, Reexam Control Number: U.S. Appl. No. 90/014,557,615 pages.

Notice of Streamlined Reexamination Request Filing Date in Reexam Control Number: U.S. Appl. No. 90/014,557 dated Aug. 5, 2020, 2 page.

Ex Parte Reexamination Interview Summary in Reexam Control Number: U.S. Appl. No. 90/014,557 dated Aug. 17, 2020, 3 pages.

DRD5S Surface Mount LED Downlight Vimeo Mar. 28, 2018. Accessed at <https://vimeo.com/262251260>. 4 pages.

Order Granting Request for Ex Parte Reexamination in Reexam Control Number: U.S. Appl. No. 90/014,557 dated Aug. 25, 2020, 10 pages.

\* cited by examiner

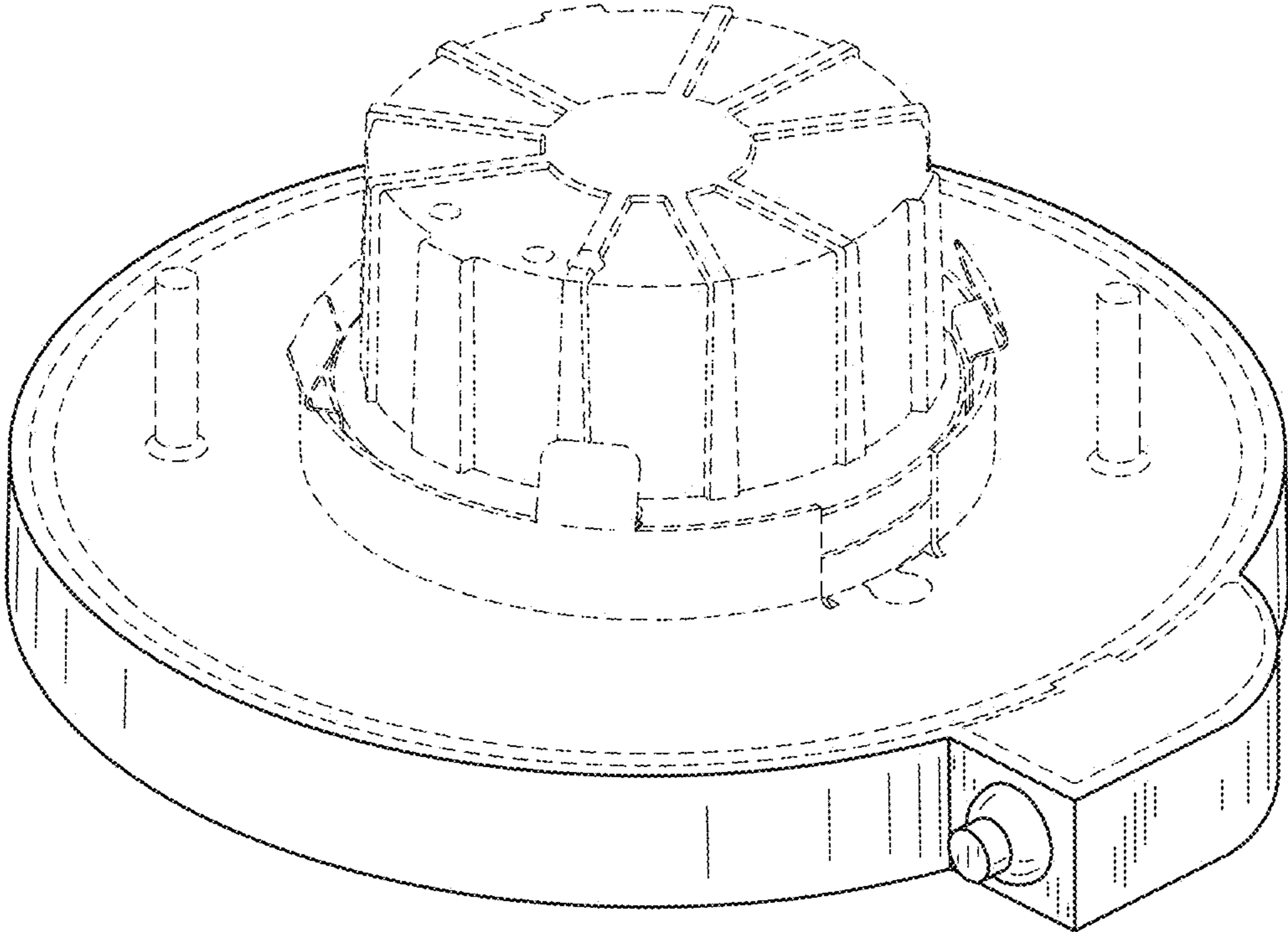

FIG. 1

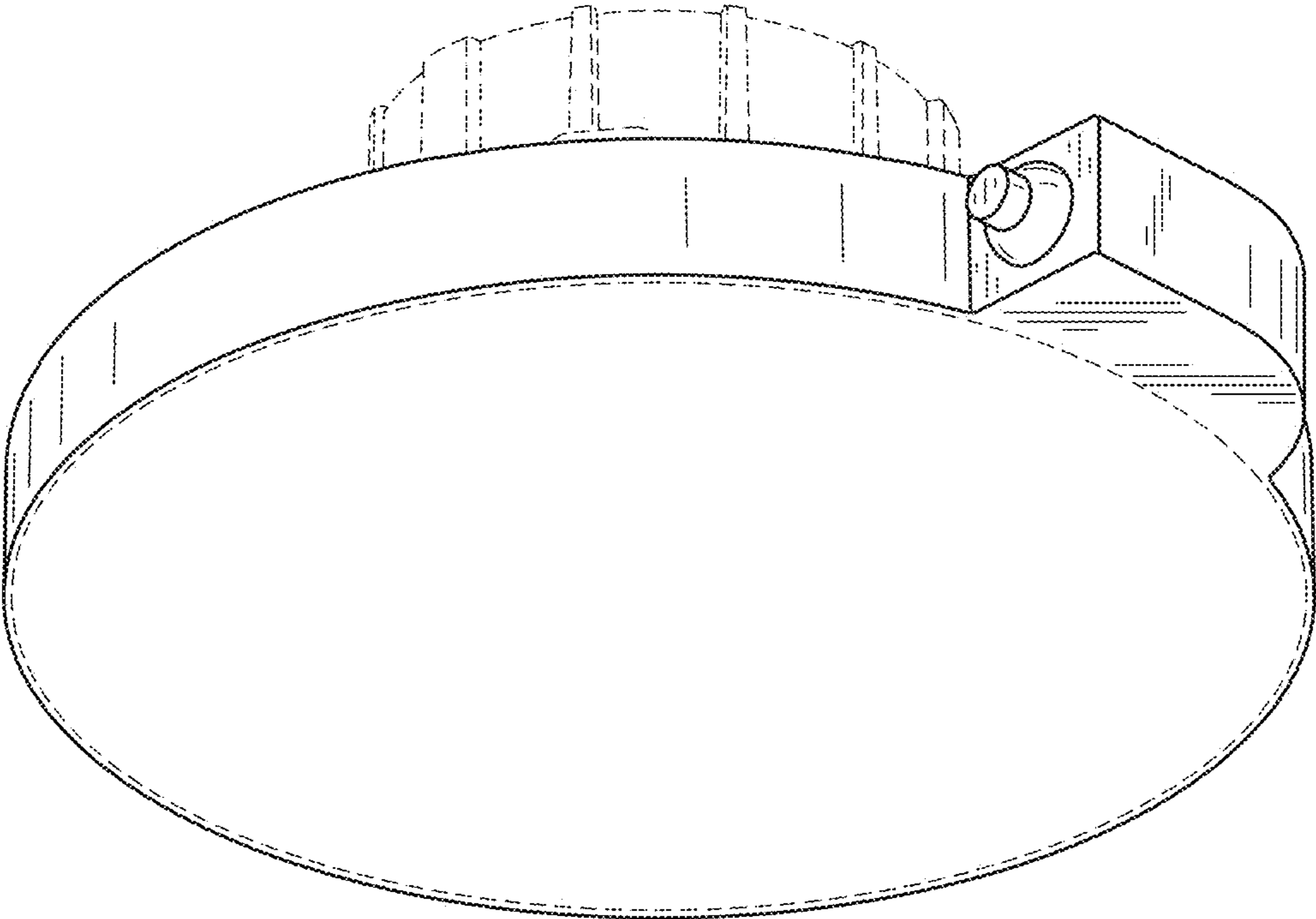

FIG. 2

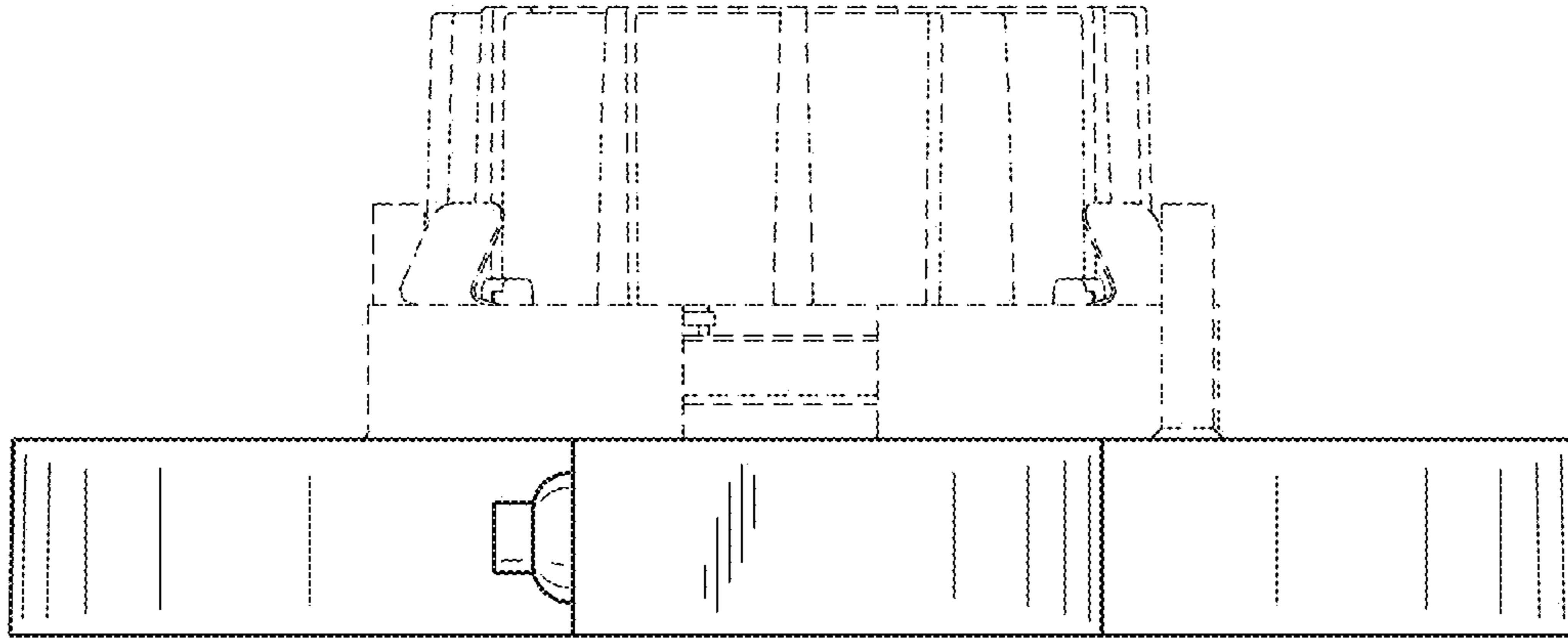

FIG. 3

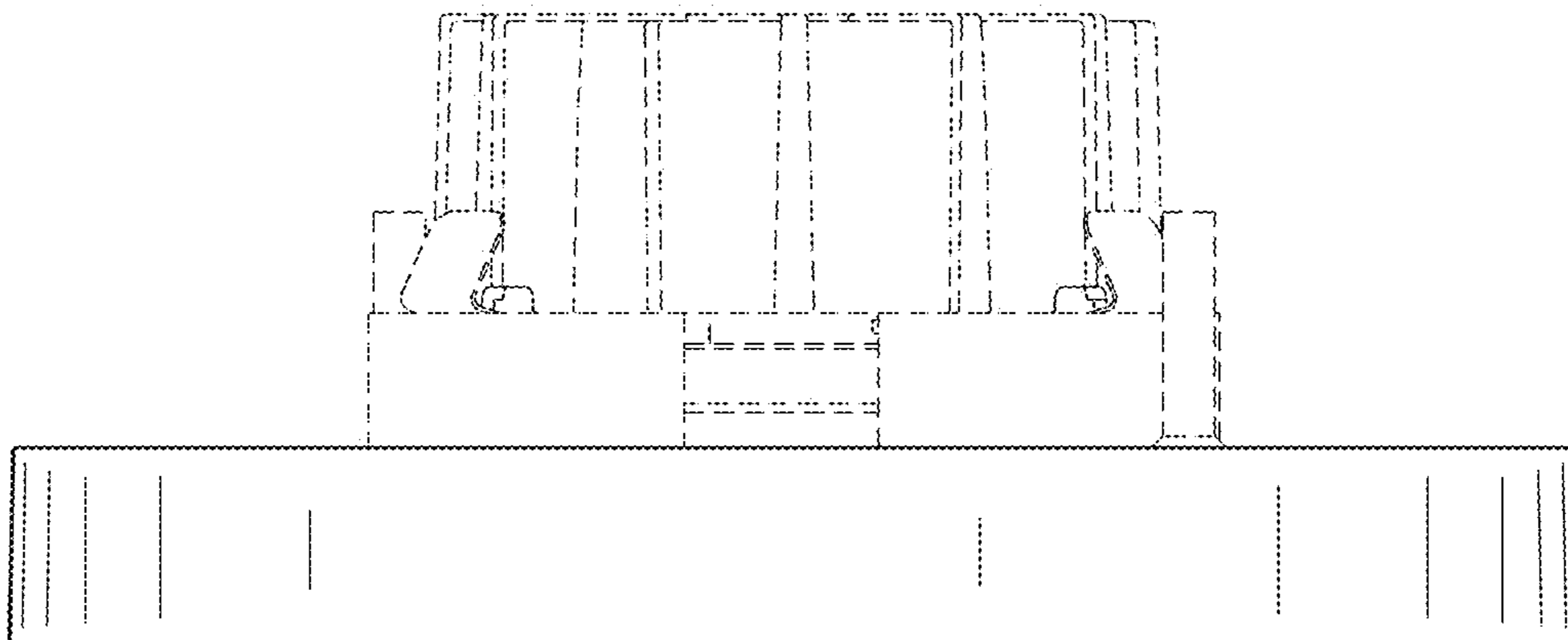

FIG. 4

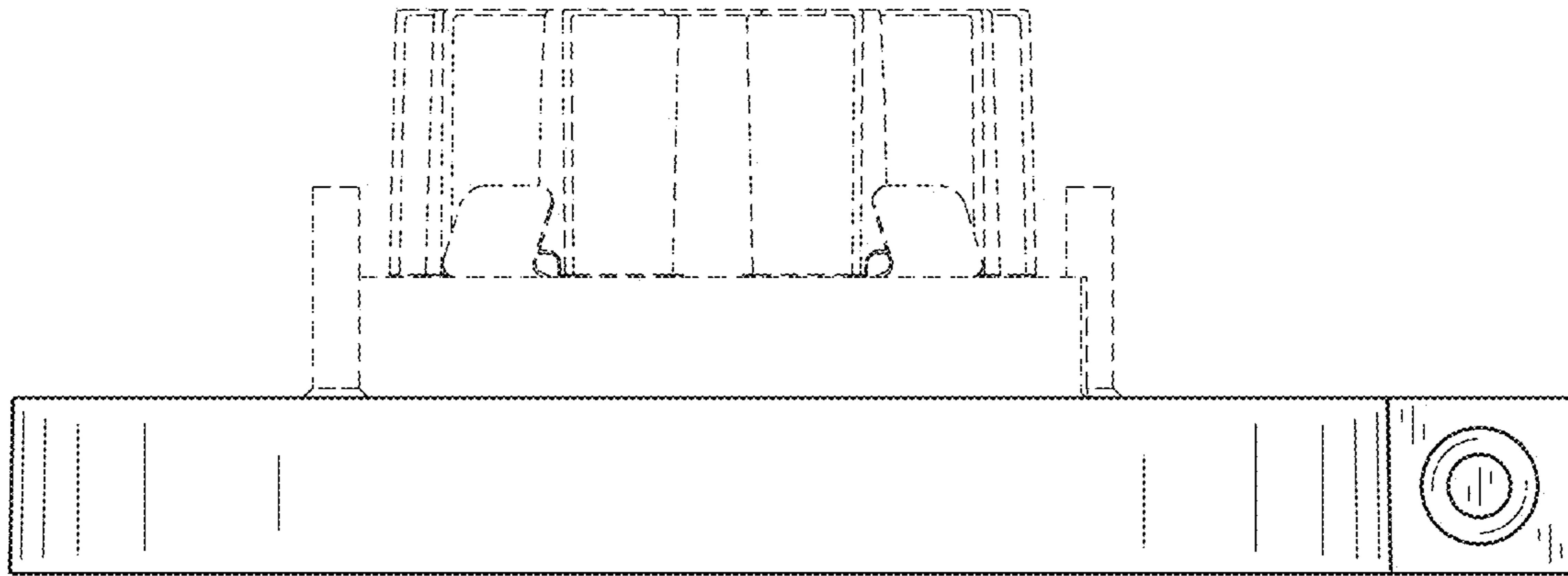

FIG. 5

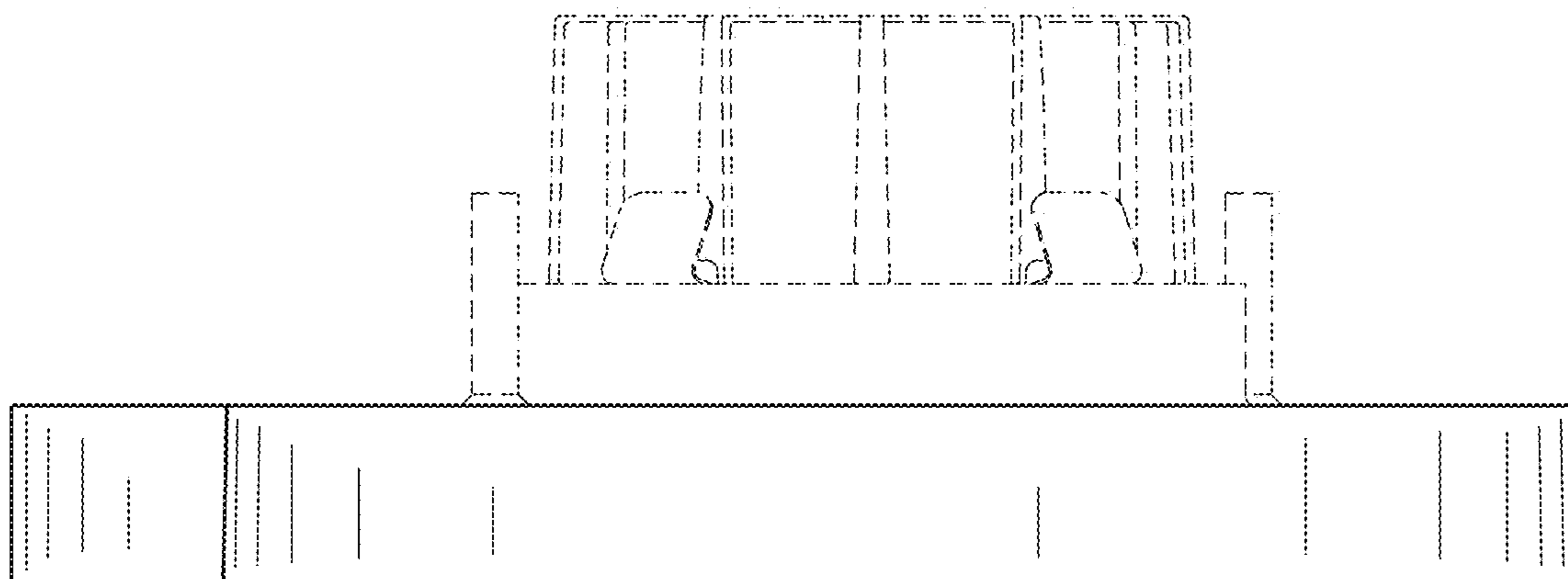

FIG. 6

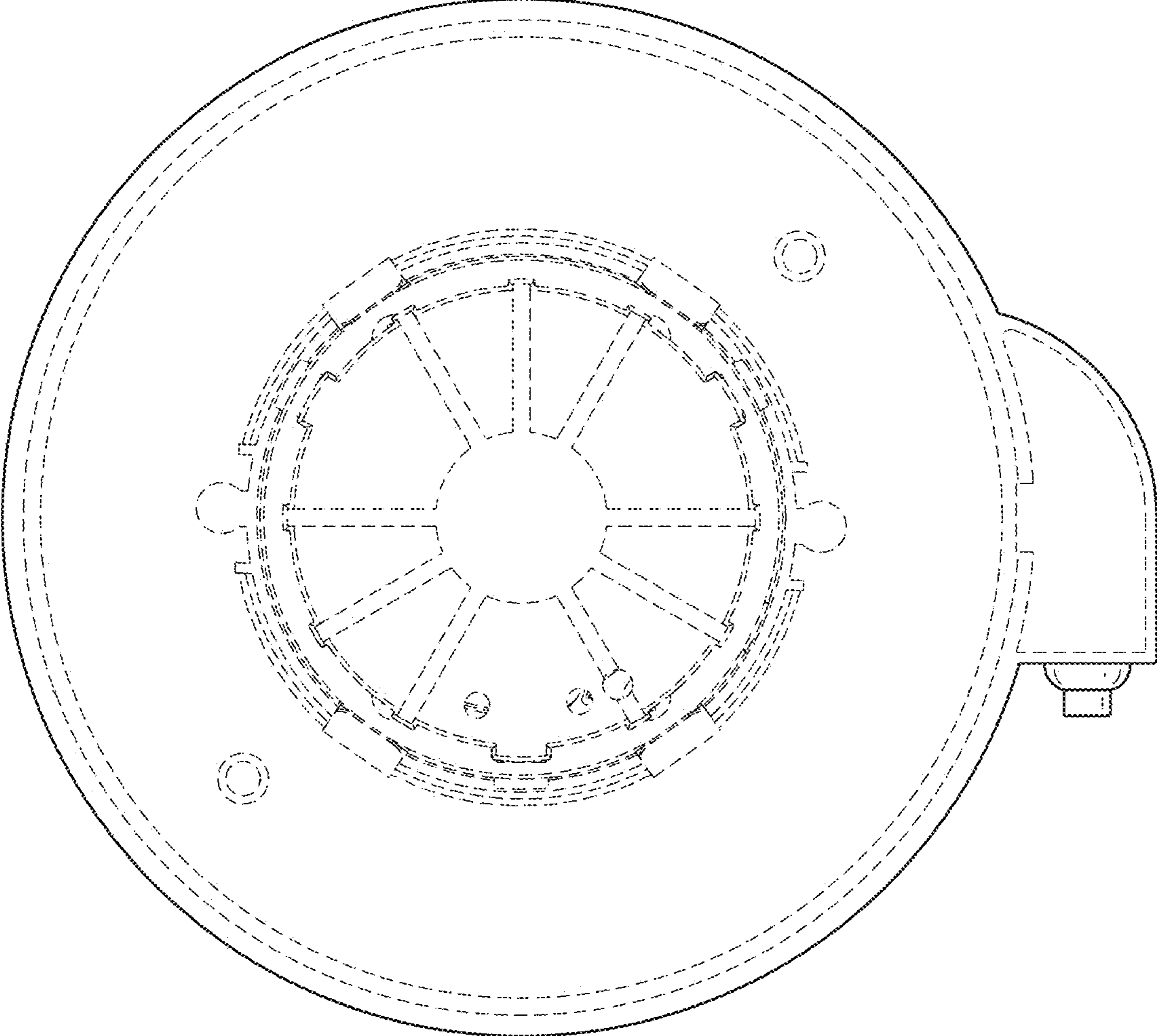

FIG. 7

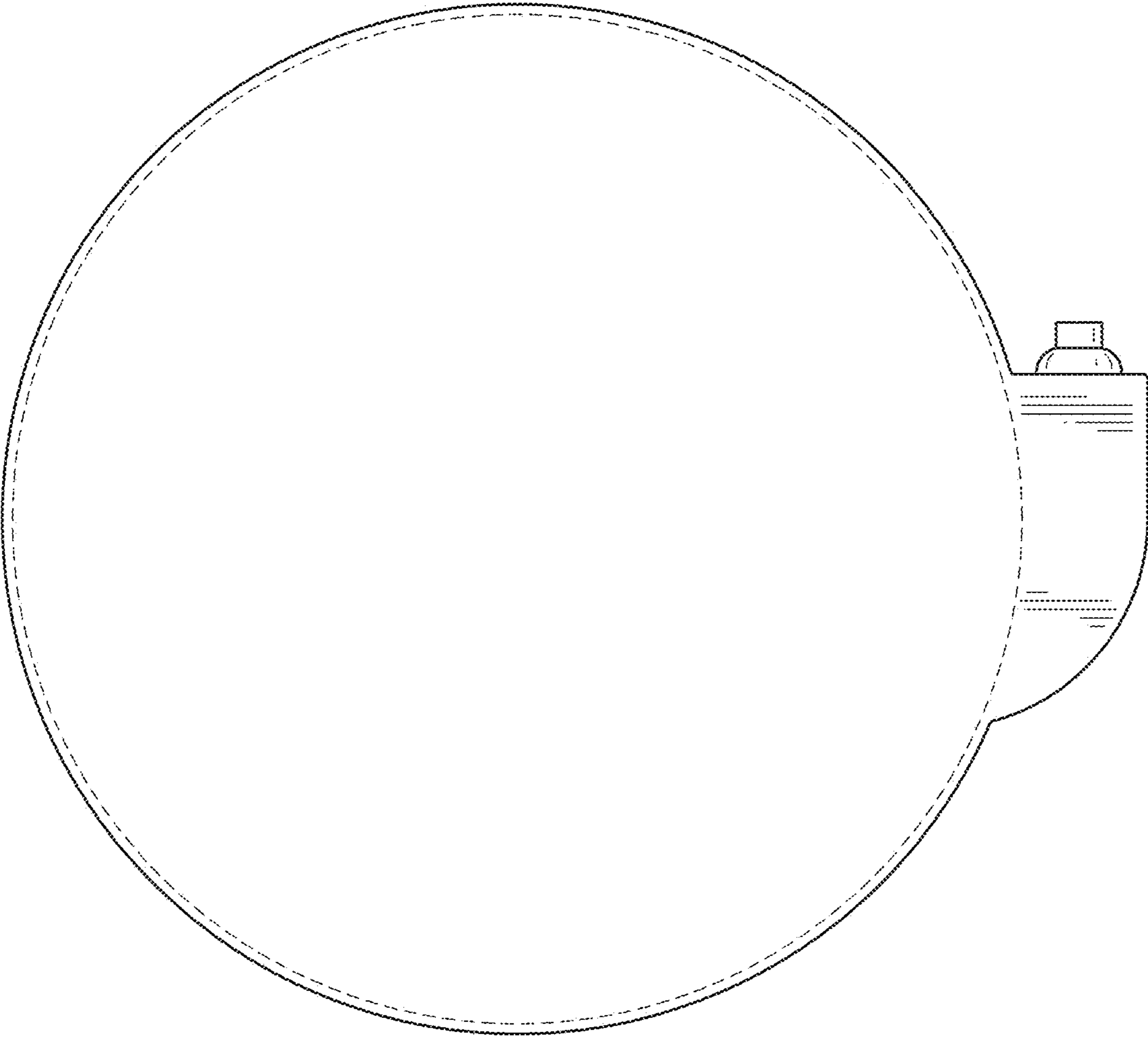

FIG. 8

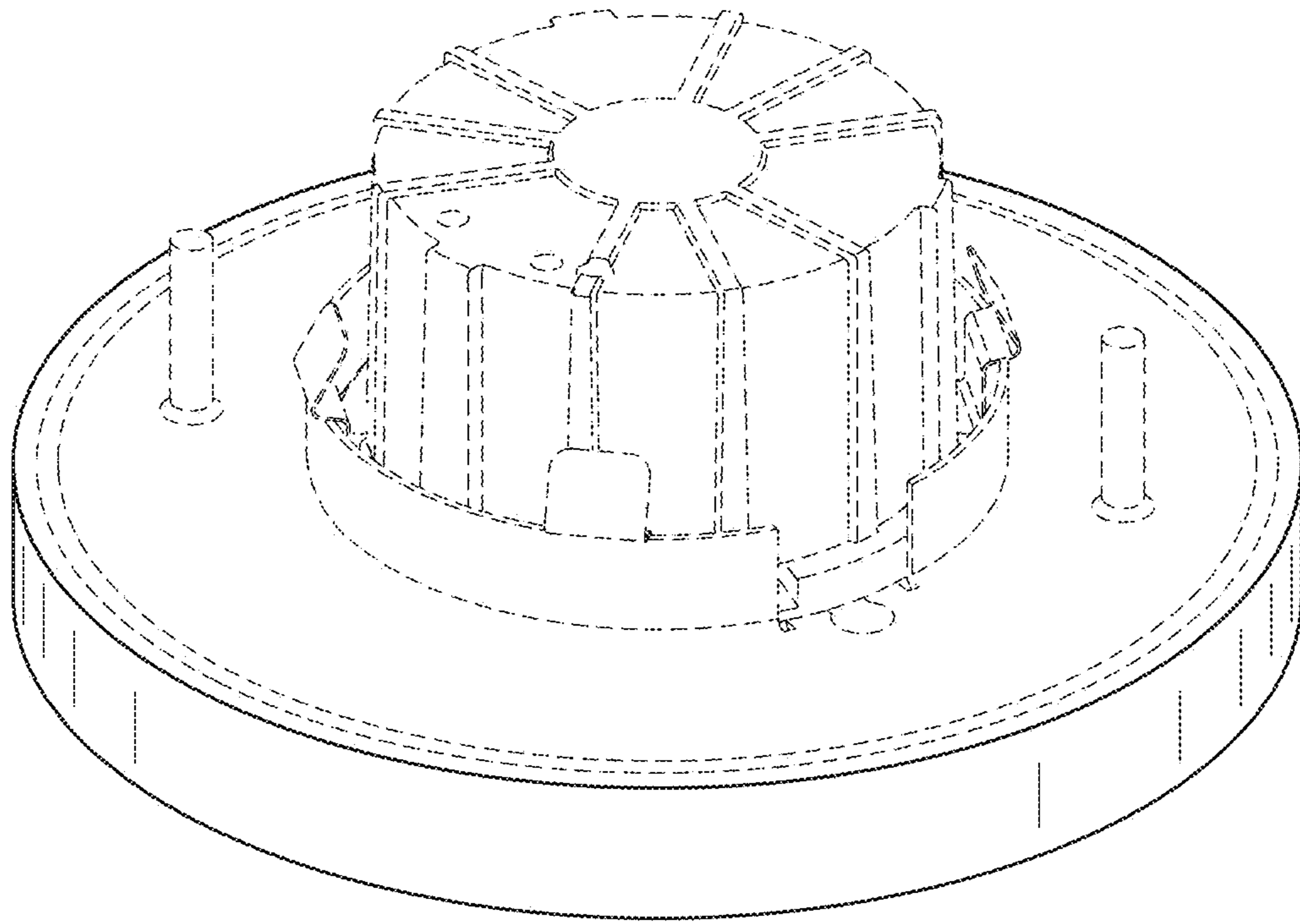

FIG. 9

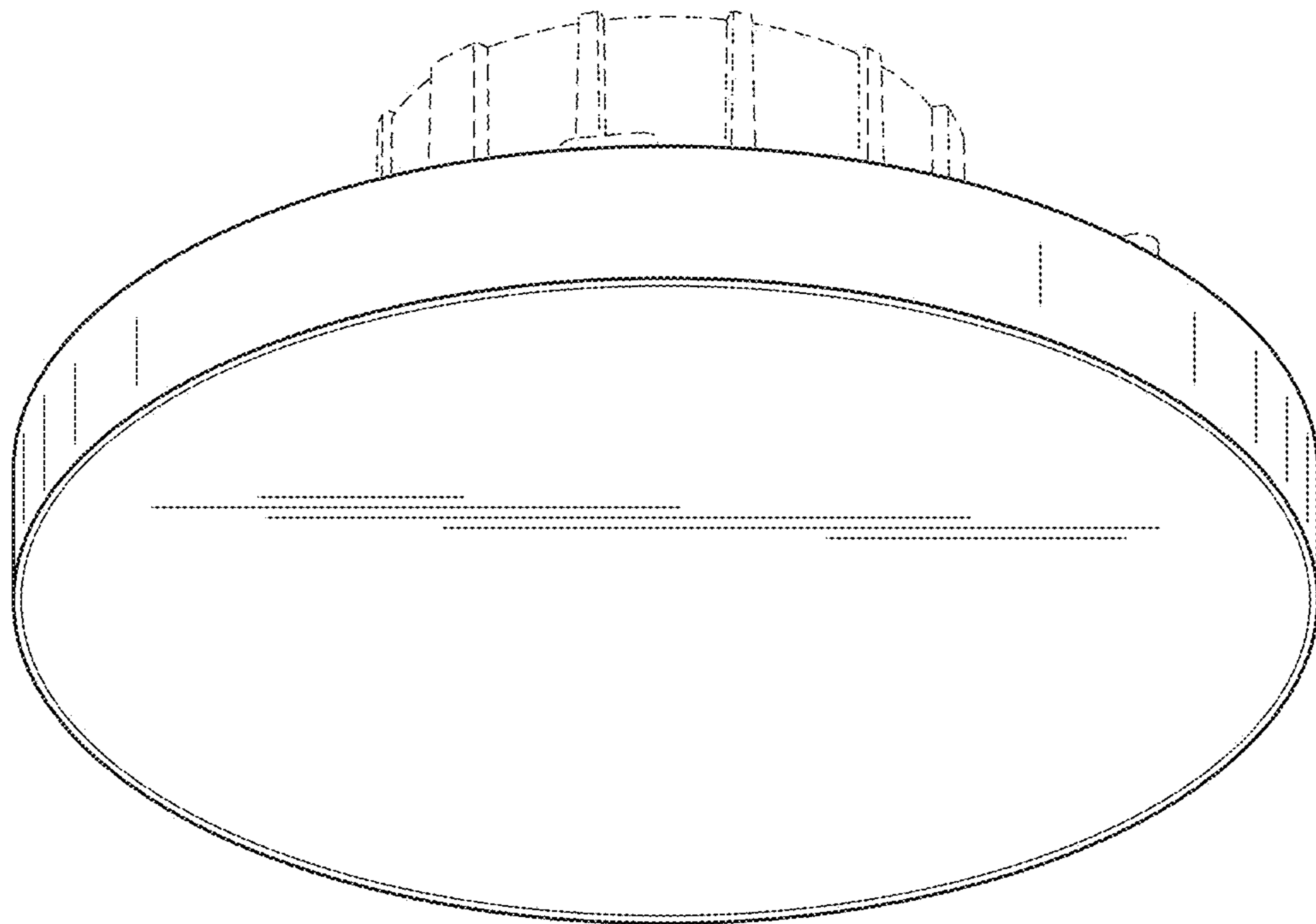

FIG. 10



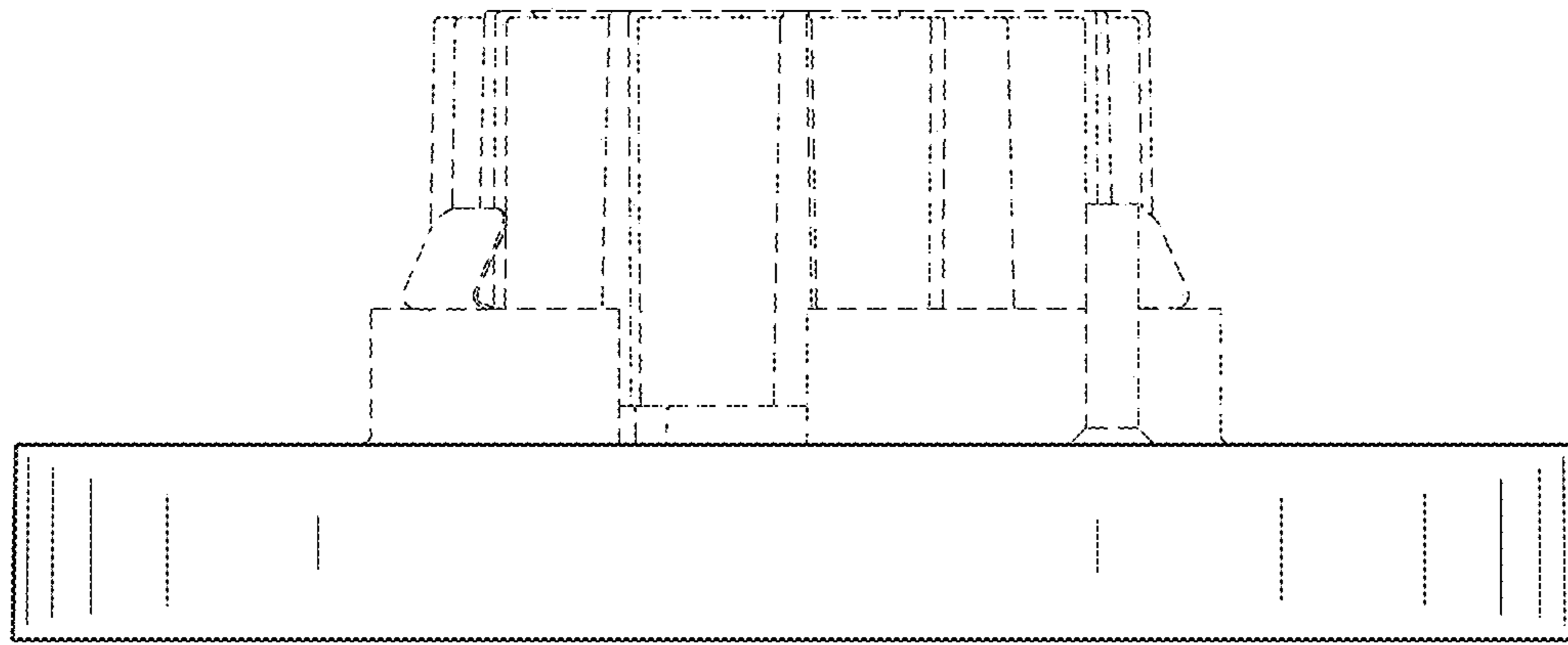

FIG. 11

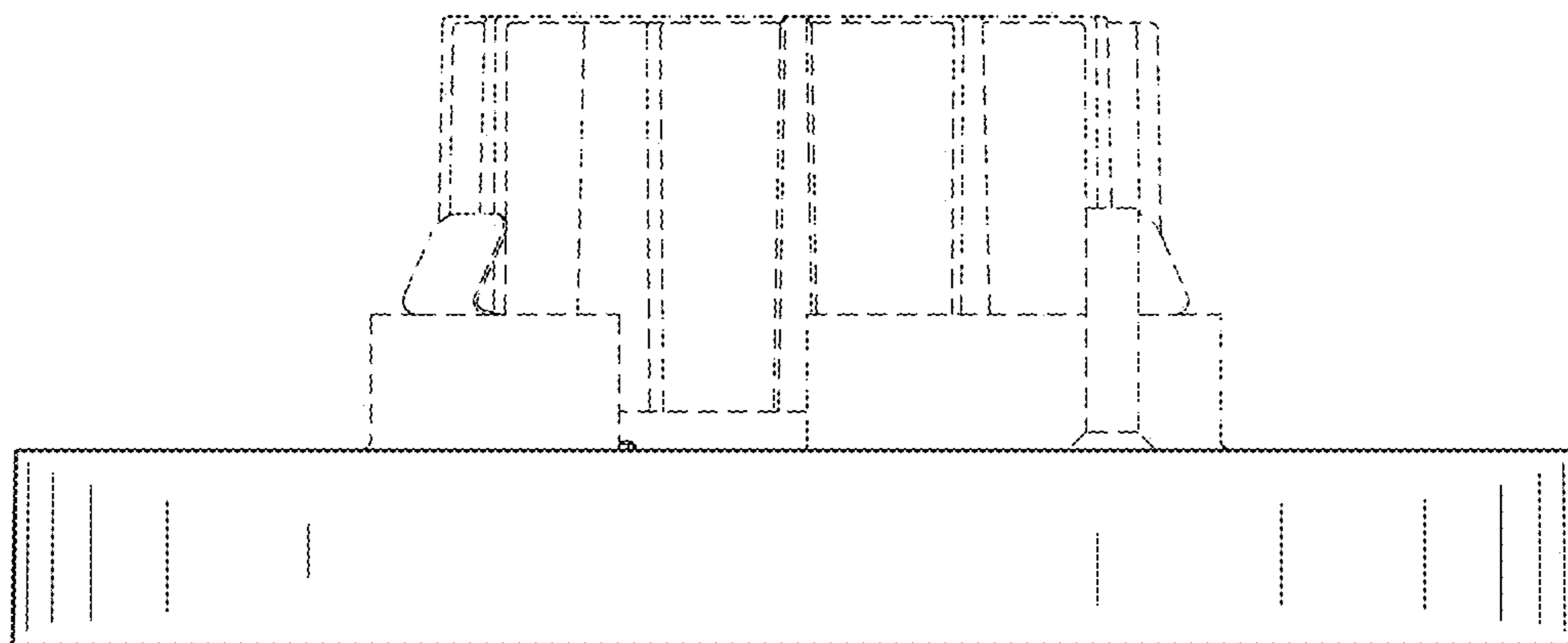

FIG. 12

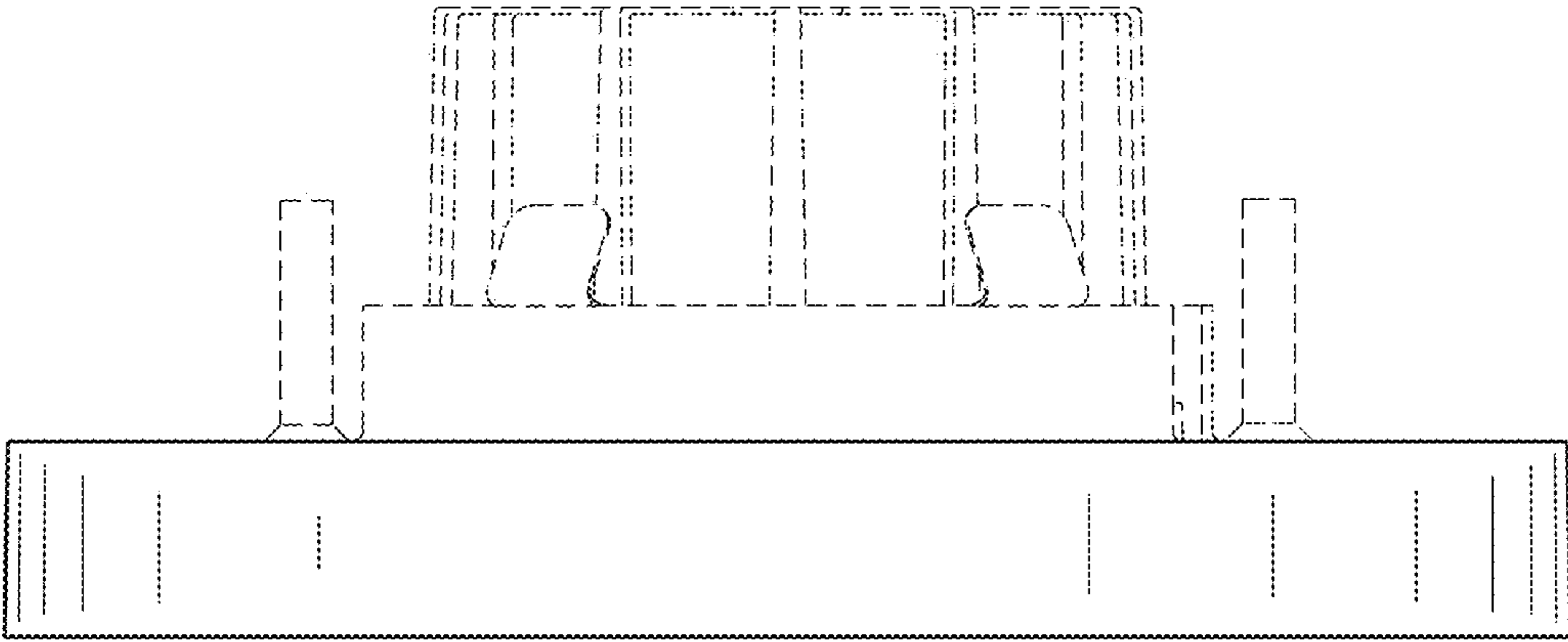

FIG. 13

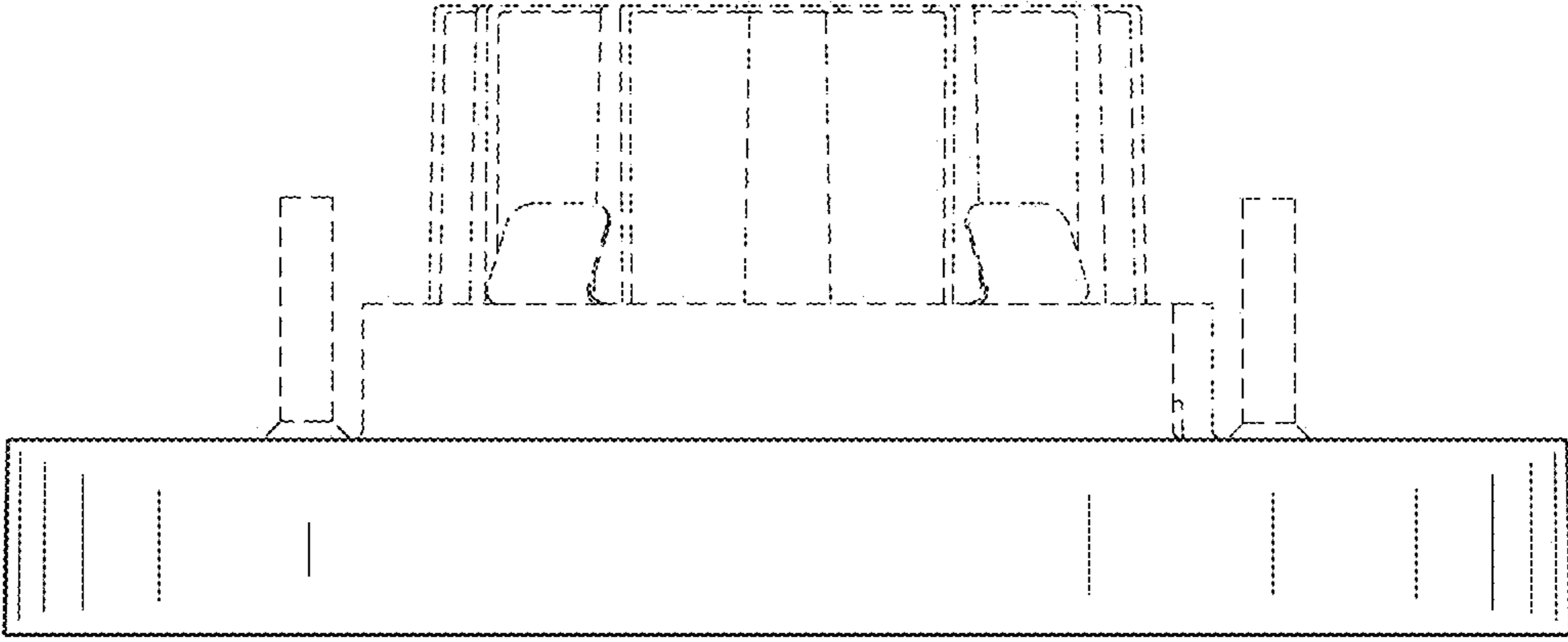

FIG. 14

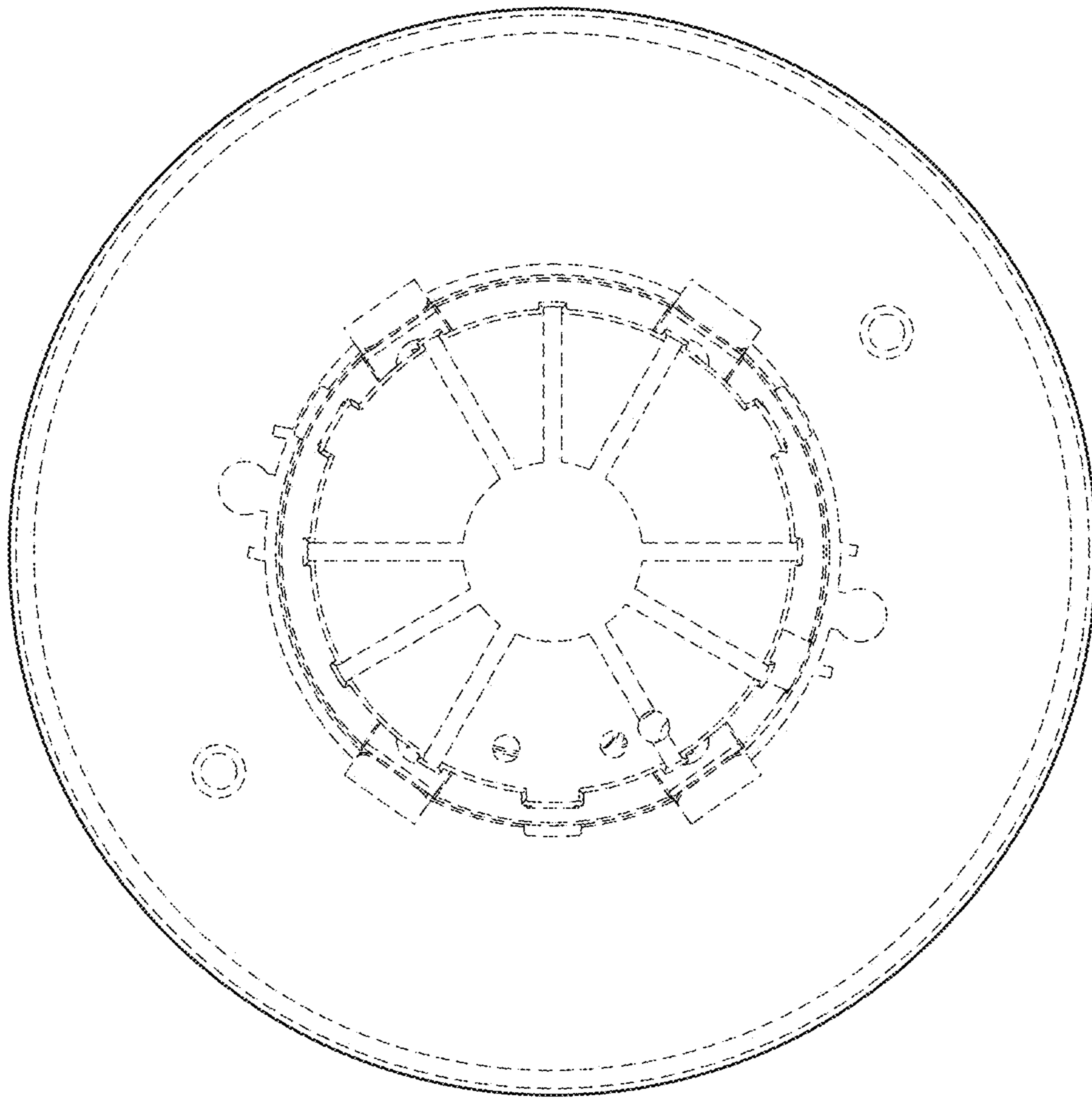

FIG. 15

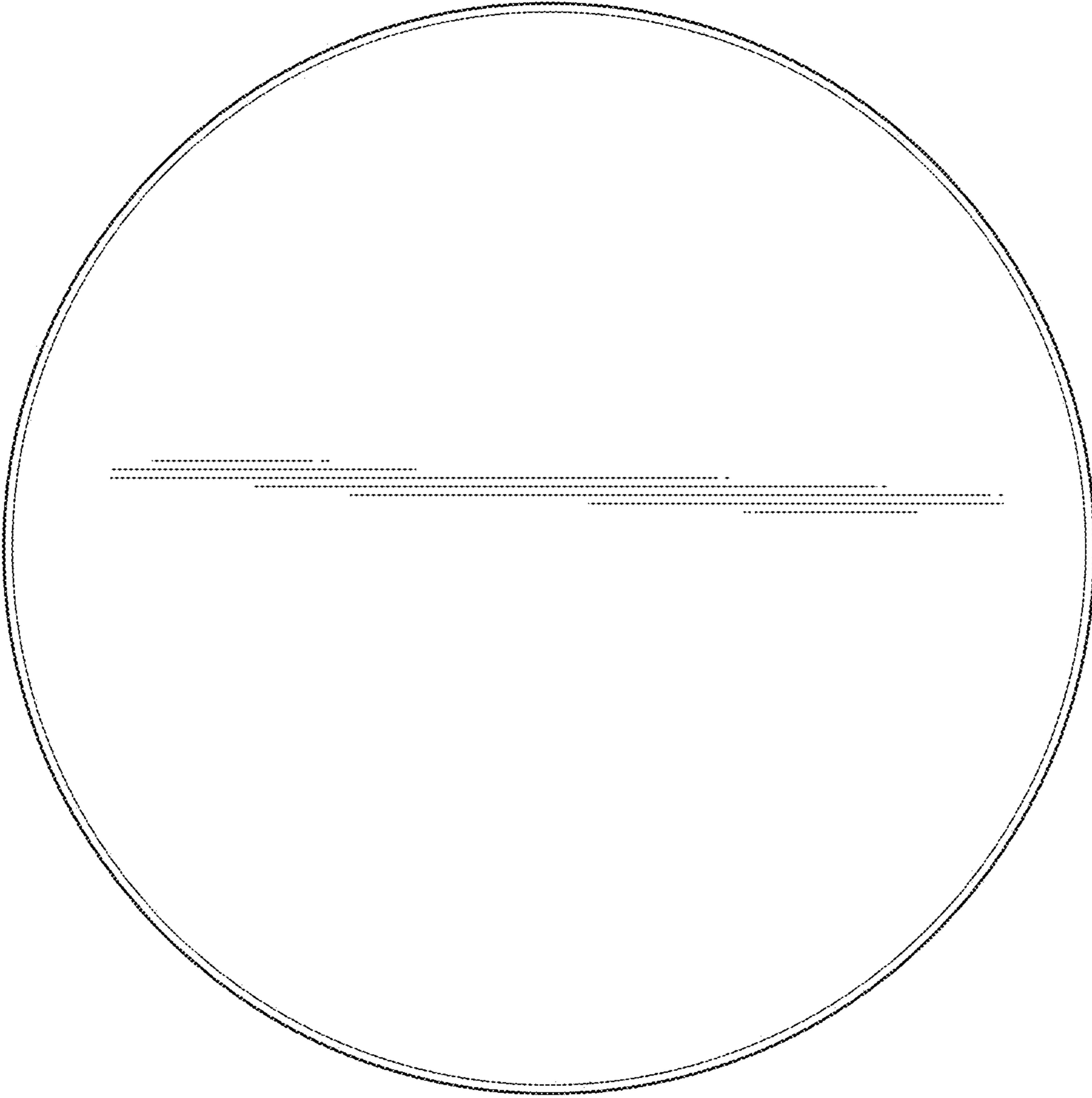

FIG. 16