



US00D905325S

(12) **United States Design Patent**  
**Antony et al.**

(10) **Patent No.:** **US D905,325 S**  
(45) **Date of Patent:** **\*\* Dec. 15, 2020**

(54) **LIGHTING MODULE**

(71) Applicant: **FLEX LTD**, Singapore (SG)  
(72) Inventors: **Ashish Antony**, Anna, TX (US); **Kevin Emr**, Dallas, TX (US); **Jordon Musser**, Dallas, TX (US)

(73) Assignee: **FLEX LTD**, Singapore (SG)

(\*\*) Term: **15 Years**

(21) Appl. No.: **29/727,398**

(22) Filed: **Mar. 10, 2020**

**Related U.S. Application Data**

(62) Division of application No. 29/613,368, filed on Aug. 9, 2017, now Pat. No. Des. 877,964.

(51) **LOC (12) Cl.** ..... **26-99**

(52) **U.S. Cl.**  
USPC ..... **D26/118**

(58) **Field of Classification Search**  
USPC ..... D26/74, 24, 72, 75, 76, 78, 79, 81, 82,  
D26/88, 89, 91, 113, 118, 119, 120, 138,  
D26/141, 142

CPC ..... F21V 21/04; F21V 21/041; F21V 7/005;  
F21Y 2111/002; F21S 8/026; F21S 8/02;  
F21S 8/04

See application file for complete search history.

(56) **References Cited**

**U.S. PATENT DOCUMENTS**

D120,548 S 5/1940 Guth  
D122,145 S 8/1940 Maccarthy  
D122,887 S 10/1940 Beals  
D123,067 S 10/1940 Rubinstein  
D123,887 S 12/1940 Koehler  
D127,398 S 5/1941 Jordan

D128,961 S 8/1941 Hrabak  
D129,726 S 9/1941 Scribner  
D130,570 S 12/1941 Borkland  
2,312,617 A 3/1943 Beck  
D139,669 S 12/1944 Lippincott  
D142,126 S 8/1945 Sabatini  
D150,735 S 8/1948 Marks  
D151,575 S 10/1948 Wyman

(Continued)

**OTHER PUBLICATIONS**

Flex Essentials Series Sell Specification Sheets, Published Jun. 2016 (28 pages).

(Continued)

*Primary Examiner* — Brian N. Vinson

(74) *Attorney, Agent, or Firm* — Weber Rosselli & Cannon LLP

(57) **CLAIM**

What is claimed the ornamental design for a lighting module, as shown and described.

**DESCRIPTION**

FIG. 1 is a top, perspective view of another embodiment of a lighting module in accordance with the present design; FIG. 2 is a bottom, perspective view of the lighting module of FIG. 1; FIG. 3 is a front view of the lighting module of FIG. 1; FIG. 4 is a rear view of the lighting module of FIG. 1; FIG. 5 is a right, side view of the lighting module of FIG. 1; FIG. 6 is a left, side view of the lighting module of FIG. 1; FIG. 7 is a top view of the lighting module of FIG. 1; and, FIG. 8 is a bottom view of the lighting module of FIG. 1. The broken lines provided in the drawings form no part of the claimed design.

**1 Claim, 6 Drawing Sheets**

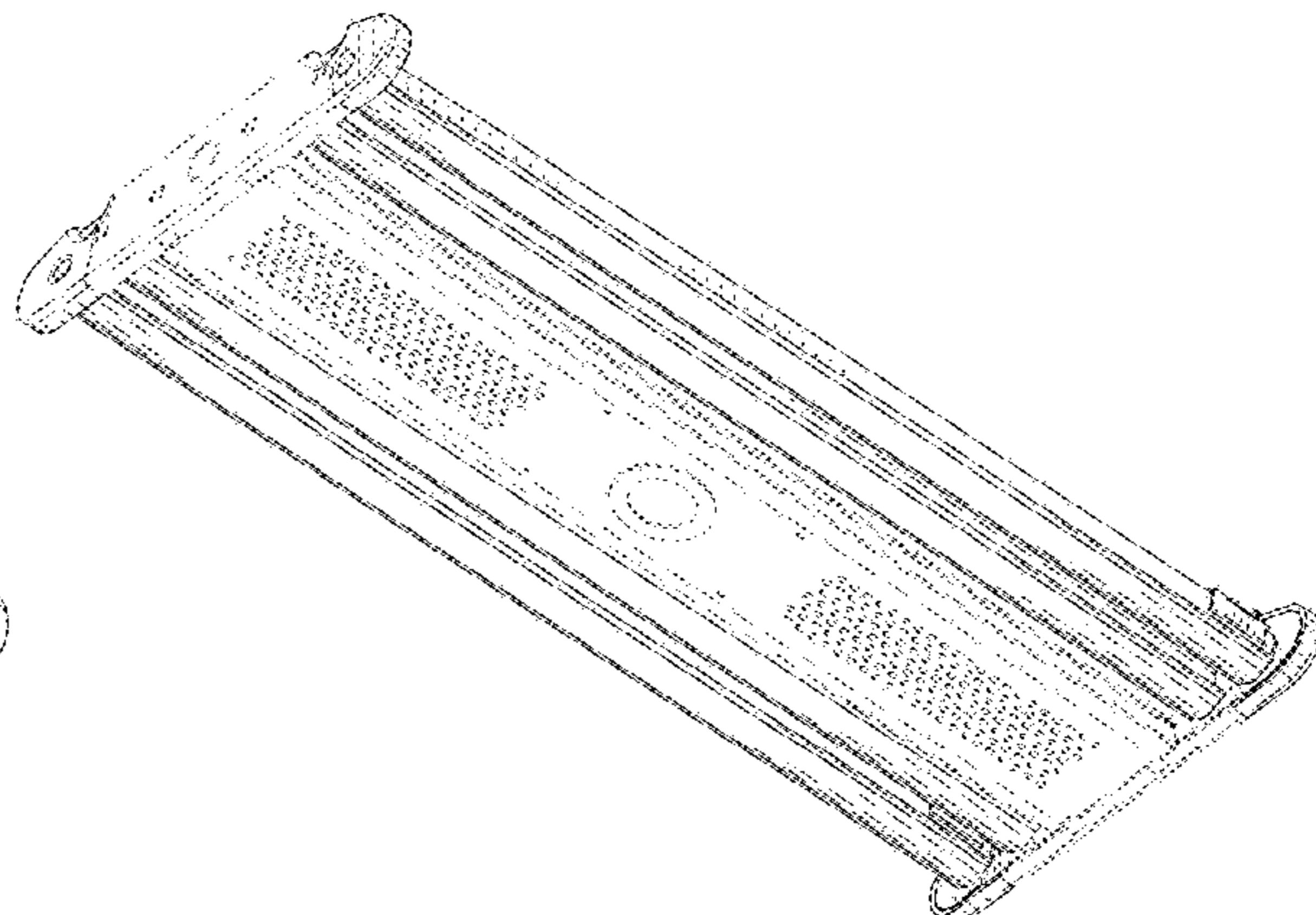
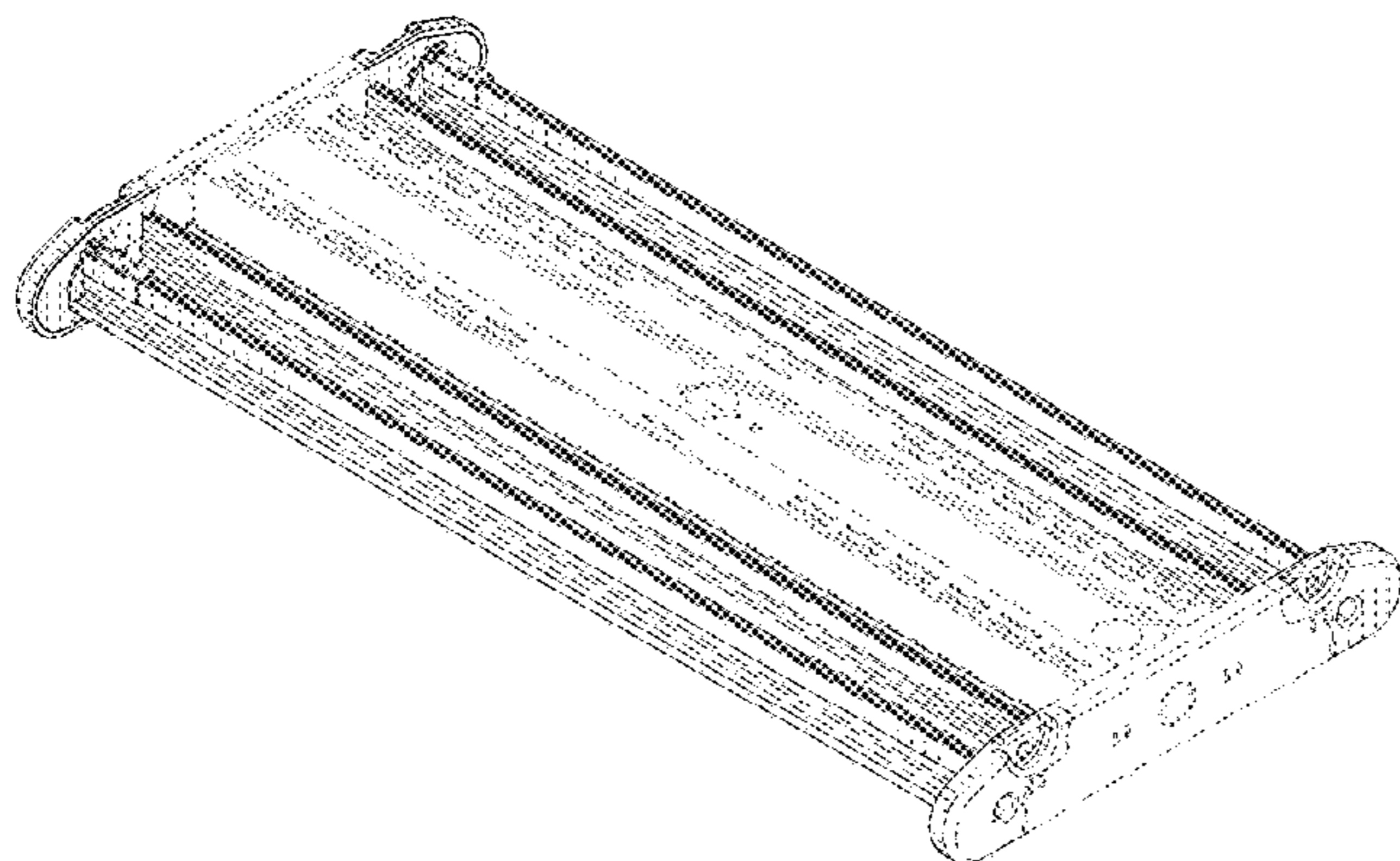

(56)

References Cited

U.S. PATENT DOCUMENTS

2,474,308	A *	6/1949	Franck .....	F21S 8/04 362/224	7,718,888	B2	5/2010	Cousins
2,606,998	A	8/1952	Winkler et al.		7,737,357	B2	6/2010	Cousins
D173,255	S	10/1954	Brooks		7,755,916	B2	7/2010	Krein et al.
2,715,449	A	8/1955	Lemmerman et al.		7,774,998	B2	8/2010	Aschenbrenner
D188,436	S	7/1960	Renaud		7,780,472	B2	8/2010	Lenox
3,009,055	A	11/1961	Michael		7,786,375	B2	8/2010	Swanson et al.
3,209,142	A	9/1965	Michel et al.		7,804,022	B2	9/2010	Ceuster
D208,491	S	9/1967	Brooks		7,807,918	B2	10/2010	Shingleton et al.
D255,851	S	7/1980	Crane		7,812,250	B2	10/2010	Smith
D291,598	S	8/1987	Elkerbout		7,820,475	B2	10/2010	Ceuster et al.
4,726,781	A	2/1988	Bemhart et al.		7,824,070	B2	11/2010	Higley et al.
6,061,978	A	5/2000	Dinwoodie et al.		7,838,062	B2	11/2010	Cousins et al.
6,076,943	A	6/2000	Lassovsky		7,851,698	B2	12/2010	Ceuster et al.
6,274,402	B1	8/2001	Verlinden et al.		D632,418	S	2/2011	Bisberg et al.
6,295,818	B1	10/2001	Ansley et al.		7,883,343	B1	2/2011	Mulligan et al.
6,313,395	B1	11/2001	Crane et al.		7,888,587	B2	2/2011	Shingleton et al.
6,333,457	B1	12/2001	Mulligan et al.		7,888,588	B2	2/2011	Shingleton
6,337,283	B1	1/2002	Verlinden et al.		7,893,409	B1	2/2011	Cousins
6,387,726	B1	5/2002	Verlinden et al.		7,897,867	B1	3/2011	Mulligan et al.
6,423,568	B1	7/2002	Verlinden et al.		7,945,413	B2	5/2011	Krein
6,495,750	B1	12/2002	Dinwoodie		7,956,281	B2	6/2011	O'Brien et al.
6,501,013	B1	12/2002	Dinwoodie		7,958,886	B2	6/2011	Barsun et al.
D472,007	S	3/2003	Weitgasser		7,982,434	B2	7/2011	Kimball et al.
6,536,326	B2	3/2003	Unger et al.		7,994,657	B2	8/2011	Kimball et al.
6,570,084	B2	5/2003	Dinwoodie		8,004,865	B2	8/2011	Krein et al.
6,684,637	B2	2/2004	Beale		8,008,575	B2	8/2011	Ceuster et al.
6,722,357	B2	4/2004	Shingleton		D644,609	S	9/2011	Marroquin
6,745,687	B1	6/2004	Kaminar		D644,610	S	9/2011	Marroquin
D492,809	S	7/2004	Weitgasser		8,029,683	B2	10/2011	Rose et al.
6,809,251	B2	10/2004	Dinwoodie		8,061,091	B2	11/2011	Botkin et al.
6,809,253	B2	10/2004	Dinwoodie		8,062,693	B2	11/2011	Cousins
6,883,290	B2	4/2005	Dinwoodie		8,065,844	B2	11/2011	Botkin et al.
D510,315	S	10/2005	Shugar et al.		8,080,819	B2	12/2011	Mueller et al.
D511,576	S	11/2005	Shingleton et al.		8,101,849	B2	1/2012	Almy et al.
D516,017	S	2/2006	Mascolo		8,108,081	B2	1/2012	Lenox
6,998,288	B1	2/2006	Smith et al.		8,120,933	B2	2/2012	Chapman et al.
D519,444	S	4/2006	Mascolo		8,134,217	B2	3/2012	Rim et al.
D521,172	S	5/2006	Chen		8,148,627	B2	4/2012	Rose et al.
7,072,096	B2	7/2006	Holman et al.		8,158,877	B2	4/2012	Klein et al.
7,135,350	B1	11/2006	Smith et al.		8,163,638	B2	4/2012	Ceuster et al.
7,140,742	B2	11/2006	Pohlert et al.		8,172,989	B2	5/2012	Pass
7,144,214	B2	12/2006	Kinpara et al.		8,174,856	B2	5/2012	Chapman
7,155,870	B2	1/2007	Almy		8,188,363	B2	5/2012	Xavier et al.
7,172,184	B2	2/2007	Pavani et al.		8,192,048	B2	6/2012	Kristoffersen et al.
7,178,295	B2	2/2007	Dinwoodie		8,192,056	B2	6/2012	Villard
7,178,941	B2	2/2007	Roberge et al.		8,193,788	B2	6/2012	Chapman
7,297,865	B2	11/2007	Terao et al.		8,198,528	B2	6/2012	Luan et al.
7,297,866	B2	11/2007	Aschenbrenner		8,206,009	B2	6/2012	Tickner et al.
D562,225	S	2/2008	Almy et al.		8,207,444	B2	6/2012	Cousins
7,328,534	B2	2/2008	Dinwoodie		8,207,637	B2	6/2012	Marroquin et al.
RE40,158	E	3/2008	Weitgasser		8,211,731	B2	7/2012	Harley et al.
D564,958	S	3/2008	Almy et al.		8,215,071	B2	7/2012	Lenox
7,339,110	B1	3/2008	Mulligan et al.		8,220,210	B2	7/2012	Botkin et al.
D565,505	S	4/2008	Shugar et al.		8,221,600	B2	7/2012	Ganti
7,388,147	B2	6/2008	Mulligan et al.		8,221,601	B2	7/2012	Chen et al.
7,390,961	B2	6/2008	Aschenbrenner et al.		8,222,516	B2	7/2012	Cousins
7,435,134	B2	10/2008	Lenox		8,227,942	B2	7/2012	Marroquin et al.
7,438,432	B2	10/2008	Yaphe et al.		8,230,850	B2	7/2012	Barsun et al.
7,455,787	B2	11/2008	Rose et al.		8,234,824	B2	8/2012	Botkin et al.
7,468,485	B1	12/2008	Swanson		8,242,354	B2	8/2012	Smith
D586,737	S	2/2009	Shugar et al.		D666,974	S	9/2012	Marroquin et al.
D592,785	S *	5/2009	Bisberg .....	D26/76	8,258,395	B2	9/2012	Wares
7,530,830	B1	5/2009	Lenox		8,263,899	B2	9/2012	Harley et al.
7,554,030	B2	6/2009	Shingleton		8,276,329	B2	10/2012	Lenox
7,554,031	B2	6/2009	Swanson et al.		8,279,642	B2	10/2012	Chapman et al.
7,557,292	B2	7/2009	Shingleton et al.		8,279,649	B2	10/2012	Esrasm et al.
7,622,912	B1	11/2009	Adams et al.		8,284,574	B2	10/2012	Chapman et al.
7,633,006	B1	12/2009	Swanson		8,291,654	B2	10/2012	Botkin et al.
7,648,257	B2	1/2010	Villard		8,294,022	B2	10/2012	Lenox
7,663,342	B2	2/2010	Kimball et al.		8,304,644	B2	11/2012	Wares et al.
7,670,638	B2	3/2010	Luan et al.		8,308,324	B2	11/2012	Horn et al.
7,681,090	B2	3/2010	Kimball et al.		8,317,987	B2	11/2012	Abas et al.
7,705,237	B2	4/2010	Swanson		D673,320	S	12/2012	Guercio et al.
7,708,578	B1	5/2010	Lenox		8,322,300	B2	12/2012	Pavani et al.
					8,324,015	B2	12/2012	Harley et al.
					8,325,499	B2	12/2012	Krein et al.
					8,334,161	B2	12/2012	Dennis et al.
					8,334,489	B2	12/2012	Beardsworth et al.
					8,336,539	B2	12/2012	Linderman et al.

(56)

References Cited

U.S. PATENT DOCUMENTS

8,350,411 B2	1/2013	Kimball et al.	8,712,745 B2	4/2014	Wayne et al.
8,350,417 B1	1/2013	Dooley et al.	8,716,596 B1	5/2014	Swanson
8,352,220 B2	1/2013	Wayne et al.	8,737,093 B1	5/2014	Baker et al.
8,360,601 B2	1/2013	Muschaweck et al.	8,737,100 B2	5/2014	Chapman et al.
8,377,738 B2	2/2013	Dennis et al.	8,744,791 B1	6/2014	Kraft et al.
8,378,706 B2	2/2013	Kinyon et al.	8,748,736 B2	6/2014	Luan et al.
8,393,707 B2	3/2013	Cudzinovic et al.	8,754,627 B1	6/2014	Le
8,399,287 B1	3/2013	Mulligan et al.	8,757,567 B2	6/2014	Ciasulli et al.
8,402,703 B2	3/2013	Brandt et al.	8,763,316 B2	7/2014	Concho et al.
8,409,902 B1	4/2013	Harley et al.	8,767,421 B2	7/2014	Chapman
8,409,911 B2	4/2013	Cousins	8,772,894 B2	7/2014	Smith
8,409,912 B2	4/2013	Ceuster et al.	8,774,007 B2	7/2014	Hussain et al.
8,423,312 B2	4/2013	Krein	8,776,781 B2	7/2014	Meydbray
8,424,255 B2	4/2013	Lenox et al.	8,778,787 B2	7/2014	Manning
8,426,974 B2	4/2013	Linderman et al.	8,785,233 B2	7/2014	Loscutoff et al.
8,448,391 B2	5/2013	Botkin et al.	8,785,236 B2	7/2014	Harley et al.
8,448,652 B2	5/2013	Almy et al.	8,785,830 B2	7/2014	Judkins
8,449,238 B2	5/2013	Mulligan et al.	8,786,095 B2	7/2014	Linderman et al.
8,450,134 B2	5/2013	Ceuster et al.	8,790,957 B2	7/2014	Li et al.
8,450,985 B2	5/2013	Gray et al.	8,793,942 B2	8/2014	Almy et al.
8,451,638 B2	5/2013	Chapman et al.	8,796,061 B2	8/2014	Bunea
8,455,806 B2	6/2013	Judkins	8,796,535 B2	8/2014	Linderman
8,456,876 B2	6/2013	Chapman	8,796,884 B2	8/2014	Naiknaware et al.
8,460,963 B2	6/2013	Smith	8,802,486 B2	8/2014	Li et al.
8,461,813 B2	6/2013	Chapman	8,809,671 B2	8/2014	Linderman et al.
8,462,518 B2	6/2013	Marroquin et al.	8,815,631 B2	8/2014	Cousins
8,482,947 B2	7/2013	Chapman et al.	8,817,510 B2	8/2014	Esrasm et al.
8,486,746 B2	7/2013	Rim et al.	8,818,924 B2	8/2014	Wayne et al.
8,492,253 B2	7/2013	Manning	8,822,257 B2	9/2014	Rim et al.
8,503,200 B2	8/2013	Chapman et al.	8,822,262 B2	9/2014	Loscutoff et al.
8,508,964 B2	8/2013	Gray et al.	8,822,812 B2	9/2014	Wares
8,516,754 B2	8/2013	Botkin et al.	8,823,356 B2	9/2014	Chapman
8,519,729 B2	8/2013	Capulong et al.	8,824,178 B1	9/2014	Baker et al.
D690,453 S	9/2013	Guercio et al.	8,839,784 B2	9/2014	Wares et al.
8,528,366 B2	9/2013	Sounni et al.	8,842,454 B2	9/2014	Johnson et al.
8,530,990 B2	9/2013	Linderman et al.	8,859,933 B2	10/2014	Harley et al.
8,534,007 B2	9/2013	Almy et al.	8,860,162 B2	10/2014	Linderman et al.
8,546,681 B2	10/2013	Wares et al.	8,860,242 B1	10/2014	Pruett et al.
8,548,637 B2	10/2013	Lenox	8,877,617 B2	11/2014	Wong et al.
8,552,288 B2	10/2013	Xavier	8,878,053 B2	11/2014	Cousins
8,557,093 B2	10/2013	Cousins et al.	8,881,415 B2	11/2014	Barton
8,558,101 B2	10/2013	Mascolo et al.	8,883,247 B2	11/2014	Cousins et al.
8,563,849 B2	10/2013	Johnston et al.	8,893,713 B2	11/2014	Wares et al.
8,567,134 B1	10/2013	Grushkowitz et al.	8,901,010 B2	12/2014	Westerberg et al.
8,572,836 B2	11/2013	Lenox	8,904,717 B2	12/2014	Lenox
8,580,599 B2	11/2013	Rim et al.	8,912,038 B2	12/2014	Li et al.
8,584,406 B2	11/2013	Wexler et al.	8,922,062 B2	12/2014	Johnson et al.
8,584,667 B2	11/2013	Linderman et al.	8,922,185 B2	12/2014	Ehlmann et al.
8,586,397 B2	11/2013	Wu et al.	8,929,094 B2	1/2015	Marroquin et al.
8,586,403 B2	11/2013	Harley et al.	8,943,765 B2	2/2015	Danning et al.
8,597,970 B2	12/2013	Cousins et al.	8,945,978 B2	2/2015	Behnke
8,599,587 B2	12/2013	Chapman et al.	8,946,541 B2	2/2015	Wares et al.
8,604,404 B1	12/2013	Linderman	8,955,267 B2	2/2015	Wexler et al.
8,609,977 B2	12/2013	Jones et al.	8,956,018 B2	2/2015	Deshpande et al.
8,611,107 B2	12/2013	Chapman et al.	8,962,082 B2	2/2015	Pavani et al.
8,615,941 B2	12/2013	Botkin et al.	8,962,373 B2	2/2015	Cousins et al.
8,624,561 B1	1/2014	Slavin	8,963,185 B2	2/2015	Cousins
8,624,621 B2	1/2014	Capulong et al.	8,963,375 B2	2/2015	DeGraaff
8,629,383 B2	1/2014	Beardsworth et al.	8,964,401 B2	2/2015	Escamilla et al.
8,630,077 B2	1/2014	Johnston et al.	8,975,175 B1	3/2015	Pass
8,634,216 B2	1/2014	Chapman	8,975,717 B2	3/2015	Smith
8,636,198 B1	1/2014	Linderman et al.	8,988,096 B1	3/2015	Naiknaware
8,647,911 B2	2/2014	Smith	8,991,682 B2	3/2015	Linderman et al.
8,650,813 B2	2/2014	Botkin et al.	8,992,803 B2	3/2015	Loscutoff et al.
8,656,660 B2	2/2014	Danning	9,010,041 B2	4/2015	Danning
8,658,454 B2	2/2014	Pass et al.	9,018,033 B2	4/2015	Wu
D700,991 S	3/2014	Johnson et al.	9,018,516 B2	4/2015	Shepherd et al.
8,661,753 B2	3/2014	Lenox	9,020,653 B2	4/2015	Lenox
8,662,008 B2	3/2014	Abas et al.	9,029,689 B2	5/2015	Phu et al.
8,664,519 B2	3/2014	Ceuster et al.	9,035,167 B2	5/2015	Swanson et al.
8,679,889 B2	3/2014	Cousins et al.	9,035,168 B2	5/2015	Barton
D703,858 S *	4/2014	Miller ..... D26/76	9,035,172 B2	5/2015	Kim et al.
8,683,761 B2	4/2014	Danning	9,035,633 B1	5/2015	Slavin et al.
8,692,111 B2	4/2014	Kim et al.	9,038,421 B2	5/2015	Sounni et al.
8,709,851 B2	4/2014	Dennis et al.	9,048,740 B2	6/2015	Gray et al.
			9,054,255 B2	6/2015	Swanson et al.
			9,059,604 B2	6/2015	Johnson
			9,062,854 B2	6/2015	Livesay et al.
			9,065,354 B2	6/2015	Chapman et al.

(56)

References Cited

U.S. PATENT DOCUMENTS

9,070,804 B2	6/2015	Cousins	9,322,437 B2	4/2016	Agullo
9,077,202 B1	7/2015	Baker	9,322,963 B2	4/2016	Linderman et al.
9,082,925 B2	7/2015	Solomon et al.	9,326,339 B2	4/2016	Nieberlein et al.
9,083,121 B2	7/2015	DeGraaff et al.	9,328,427 B2	5/2016	Behnke
9,087,939 B2	7/2015	Harley et al.	9,329,322 B2	5/2016	Yamada et al.
9,093,919 B2	7/2015	Chapman et al.	9,337,369 B2	5/2016	Smith
9,101,082 B1	8/2015	Dorenkamp et al.	9,342,088 B2	5/2016	Batten et al.
9,112,066 B2	8/2015	Dennis et al.	9,347,619 B2	5/2016	Schupple et al.
9,112,097 B2	8/2015	Tu	9,353,970 B2	5/2016	Linderman et al.
9,116,202 B2	8/2015	Capulong et al.	9,362,427 B2	6/2016	Sewell et al.
9,136,710 B1	9/2015	Baker et al.	D824,581 S *	7/2018	Tweel ..... D26/118
9,142,696 B2	9/2015	Loscutoff et al.	2002/0181229 A1	12/2002	Wei
9,147,795 B2	9/2015	Li et al.	2011/0312119 A1	12/2011	Rose et al.
9,153,712 B2	10/2015	Zhu	2012/0134189 A1	5/2012	Krein et al.
9,159,521 B1	10/2015	Chen et al.	2012/0180845 A1	7/2012	Cole et al.
9,160,408 B2	10/2015	Krohne et al.	2012/0192925 A1	8/2012	Grushkowitz et al.
9,166,079 B2	10/2015	Manning	2012/0216852 A1	8/2012	Almy et al.
9,178,104 B2	11/2015	Moors et al.	2013/0000694 A1	1/2013	Bunea et al.
9,184,324 B2	11/2015	Wares et al.	2013/0106196 A1	5/2013	Johnson et al.
9,184,327 B2	11/2015	Rose et al.	2013/0239947 A1	9/2013	Almy et al.
9,185,759 B2	11/2015	Nieberlein et al.	2013/0255749 A1	10/2013	Kinyon et al.
9,186,741 B2	11/2015	Kumaria et al.	2013/0305787 A1	11/2013	Berrada et al.
9,190,839 B2	11/2015	Johnston et al.	2013/0340379 A1	12/2013	Danning et al.
9,193,014 B2	11/2015	Danning	2013/0340380 A1	12/2013	Danning et al.
9,196,758 B2	11/2015	Rim et al.	2014/0000187 A1	1/2014	Botkin et al.
D744,684 S	12/2015	Guercio et al.	2014/0000695 A1	1/2014	Stone et al.
D744,690 S	12/2015	Boyer et al.	2014/0000705 A1	1/2014	Sounni et al.
9,202,960 B2	12/2015	Luan et al.	2014/0014499 A1	1/2014	Cousins et al.
9,212,808 B2	12/2015	Higley et al.	2014/0034111 A1	2/2014	Bunea et al.
9,217,206 B2	12/2015	Behnke et al.	2014/0034122 A1	2/2014	Cousins et al.
9,219,173 B2	12/2015	Swanson et al.	2014/0034455 A1	2/2014	Mulligan et al.
9,222,193 B2	12/2015	Abas et al.	2014/0036563 A1	2/2014	Chapman et al.
9,224,902 B2	12/2015	Swanson	2014/0048119 A1	2/2014	Johnston et al.
9,225,256 B2	12/2015	Chapman et al.	2014/0090637 A1	4/2014	Grushkowitz
9,225,285 B2	12/2015	Peurach et al.	2014/0090638 A1	4/2014	Grushkowitz
9,231,129 B2	1/2016	Harley et al.	2014/0090701 A1	4/2014	Rim et al.
9,231,145 B2	1/2016	Smith	2014/0102505 A1	4/2014	Lenox
9,239,153 B2	1/2016	Goodman et al.	2014/0102512 A1	4/2014	Jones et al.
9,240,682 B2	1/2016	Sivakumar et al.	2014/0116495 A1	5/2014	Kim et al.
9,243,818 B2	1/2016	Shugar et al.	2014/0133197 A1	5/2014	Chapman et al.
9,246,037 B2	1/2016	Linderman	2014/0150846 A1	6/2014	Beardsworth et al.
9,246,046 B1	1/2016	Harrington et al.	2014/0174905 A1	6/2014	Landry
9,249,044 B2	2/2016	Judkins et al.	2014/0182661 A1	7/2014	Kinyon
9,249,523 B2	2/2016	Rim	2014/0190561 A1	7/2014	De et al.
9,252,314 B2	2/2016	Wares et al.	2014/0202492 A1	7/2014	Grossman et al.
9,252,319 B2	2/2016	Loscutoff et al.	2014/0238470 A1	8/2014	Ciasulli et al.
9,253,935 B2	2/2016	Morris et al.	2014/0261626 A1	9/2014	Ripoll et al.
9,257,575 B1	2/2016	Pass et al.	2014/0268908 A1	9/2014	Zhou et al.
9,257,847 B2	2/2016	Johnson et al.	2014/0290715 A1	10/2014	Meydbray et al.
9,263,183 B2	2/2016	Chapman et al.	2014/0291852 A1	10/2014	Linderman et al.
9,263,601 B2	2/2016	Wu et al.	2014/0305501 A1	10/2014	Li et al.
9,263,602 B2	2/2016	Harley et al.	2014/0306092 A1	10/2014	Judkins et al.
9,263,622 B2	2/2016	Pass et al.	2014/0311054 A1	10/2014	Concho et al.
9,263,625 B2	2/2016	Smith et al.	2014/0322855 A1	10/2014	Bunea et al.
9,263,895 B2	2/2016	Naiknaware et al.	2014/0345688 A1	11/2014	Cousins et al.
9,266,468 B2	2/2016	Mizushiro et al.	2014/0352761 A1	12/2014	Linderman et al.
9,267,649 B2	2/2016	Janik et al.	2014/0373910 A1	12/2014	Luan et al.
D751,976 S	3/2016	Mackler et al.	2015/0000724 A1	1/2015	Pass et al.
9,273,845 B2	3/2016	Eom et al.	2015/0004737 A1	1/2015	Harley et al.
9,276,635 B2	3/2016	Rothblum et al.	2015/0020867 A1	1/2015	Linderman et al.
9,279,457 B2	3/2016	Grushkowitz	2015/0040944 A1	2/2015	Dinwoodie et al.
9,279,569 B2	3/2016	Lamonato et al.	2015/0047690 A1	2/2015	Shen et al.
9,281,419 B2	3/2016	Klein et al.	2015/0053248 A1	2/2015	Rim et al.
9,281,429 B2	3/2016	Xavier et al.	2015/0083215 A1	3/2015	Cousins
9,281,431 B2	3/2016	Linderman	2015/0090328 A1	4/2015	Smith
9,285,081 B2	3/2016	Douglas et al.	2015/0090329 A1	4/2015	Pass et al.
9,293,624 B2	3/2016	Cudzinovic et al.	2015/0108692 A1	4/2015	Harley et al.
9,300,224 B2	3/2016	Johnson et al.	2015/0117067 A1	4/2015	Naiknaware et al.
D754,064 S	4/2016	Mackler et al.	2015/0122305 A1	5/2015	Marroquin et al.
9,303,285 B2	4/2016	Piazza et al.	2015/0128437 A1	5/2015	Barton
9,306,085 B2	4/2016	Westerberg et al.	2015/0144197 A1	5/2015	Cousins et al.
9,312,042 B2	4/2016	Sewell et al.	2015/0146315 A1	5/2015	Wares et al.
9,312,406 B2	4/2016	Loscutoff et al.	2015/0155819 A1	6/2015	Wexler et al.
9,312,425 B2	4/2016	Kim et al.	2015/0163074 A1	6/2015	Pruett et al.
9,316,417 B2	4/2016	Danning	2015/0180238 A1	6/2015	Degraaff et al.
			2015/0180404 A1	6/2015	Braunstein et al.
			2015/0194539 A1	7/2015	Shepherd et al.
			2015/0194927 A1	7/2015	Naiknaware et al.
			2015/0206988 A1	7/2015	Loscutoff et al.

(56)

**References Cited**

U.S. PATENT DOCUMENTS

2015/0212535 A1 7/2015 Ehlmann et al.  
 2015/0214744 A1 7/2015 Lenox  
 2015/0222225 A1 8/2015 Danning  
 2015/0229221 A1 8/2015 Gray et al.  
 2015/0249405 A1 9/2015 Chapman et al.  
 2015/0249423 A1 9/2015 Braunstein et al.  
 2015/0263200 A1 9/2015 Dennis et al.  
 2015/0270803 A1 9/2015 Barton et al.  
 2015/0280038 A1 10/2015 Sethi et al.  
 2015/0282365 A1 10/2015 Escamilla et al.  
 2015/0287875 A1 10/2015 Phu et al.  
 2015/0288328 A1 10/2015 Swanson et al.  
 2015/0311357 A1 10/2015 Harley et al.  
 2015/0325710 A1 11/2015 Tu et al.  
 2015/0326168 A1 11/2015 Johnson et al.  
 2015/0326178 A1 11/2015 Capulong et al.  
 2015/0333617 A1 11/2015 Chapman et al.  
 2015/0340868 A1 11/2015 Chapman et al.  
 2015/0342084 A1 11/2015 Dorenkamp et al.  
 2015/0349158 A1 12/2015 Manning  
 2015/0349706 A1 12/2015 Grossman et al.  
 2015/0349709 A1 12/2015 Ponec et al.  
 2015/0364625 A1 12/2015 Solomon et al.  
 2015/0372638 A1 12/2015 Degraaff et al.  
 2015/0377518 A1 12/2015 Maxey et al.  
 2015/0380578 A1 12/2015 Zhu et al.  
 2016/0011246 A1 1/2016 Fischer et al.  
 2016/0020827 A1 1/2016 Krohne et al.  
 2016/0027953 A1 1/2016 Moors et al.

2016/0028345 A1 1/2016 Wares et al.  
 2016/0035908 A1 2/2016 Rose et al.  
 2016/0036380 A1 2/2016 Johnston et al.  
 2016/0043267 A1 2/2016 Rim et al.  
 2016/0043684 A1 2/2016 Harif  
 2016/0064576 A1 3/2016 Luan et al.  
 2016/0065119 A1 3/2016 Danning et al.  
 2016/0071991 A1 3/2016 Smith et al.  
 2016/0071996 A1 3/2016 Swanson et al.  
 2016/0071999 A1 3/2016 Loscutoff et al.  
 2016/0079450 A1 3/2016 Harley et al.  
 2016/0079911 A1 3/2016 Rose et al.  
 2016/0087425 A1 3/2016 Sivakumar et al.  
 2016/0090662 A1 3/2016 Capulong et al.  
 2016/0105027 A1 4/2016 Johnson et al.  
 2016/0108541 A1 4/2016 Abas et al.  
 2016/0111583 A1 4/2016 Harrington et al.  
 2016/0112003 A1 4/2016 Morris et al.  
 2016/0118516 A1 4/2016 Harley et al.  
 2016/0133759 A1 5/2016 Pass et al.  
 2016/0133767 A1 5/2016 Smith et al.  
 2016/0134233 A1 5/2016 Chapman et al.  
 2016/0142100 A1 5/2016 Rothblum et al.  
 2016/0156309 A1 6/2016 Almogy et al.  
 2016/0164300 A1 6/2016 Johnson et al.  
 2016/0164427 A1 6/2016 Chapman et al.

OTHER PUBLICATIONS

Flex Lighting Solutions Specification Sheets, Essentials Series 4.0,  
 Published May 2017 (9 pages).

\* cited by examiner

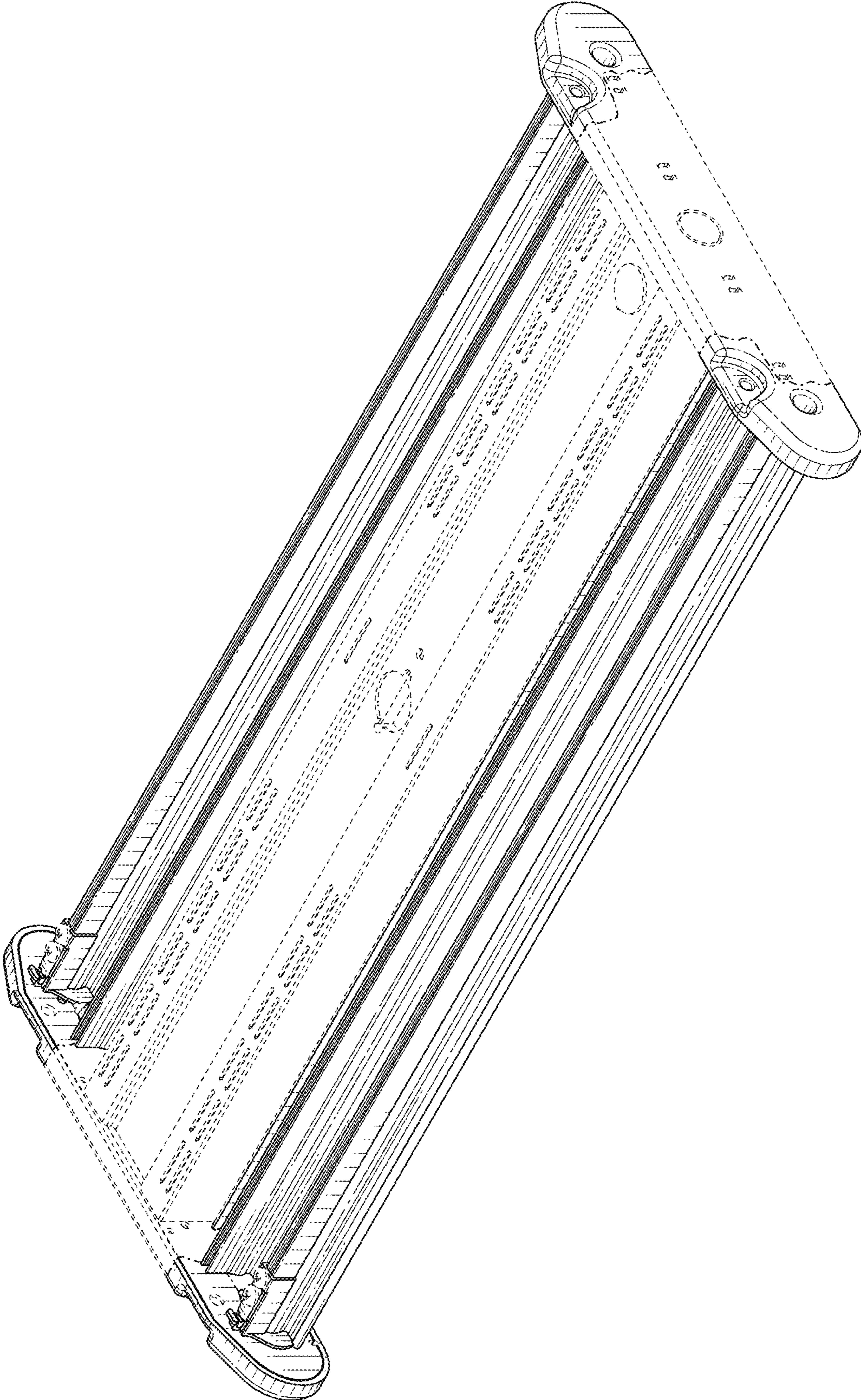

FIG. 1

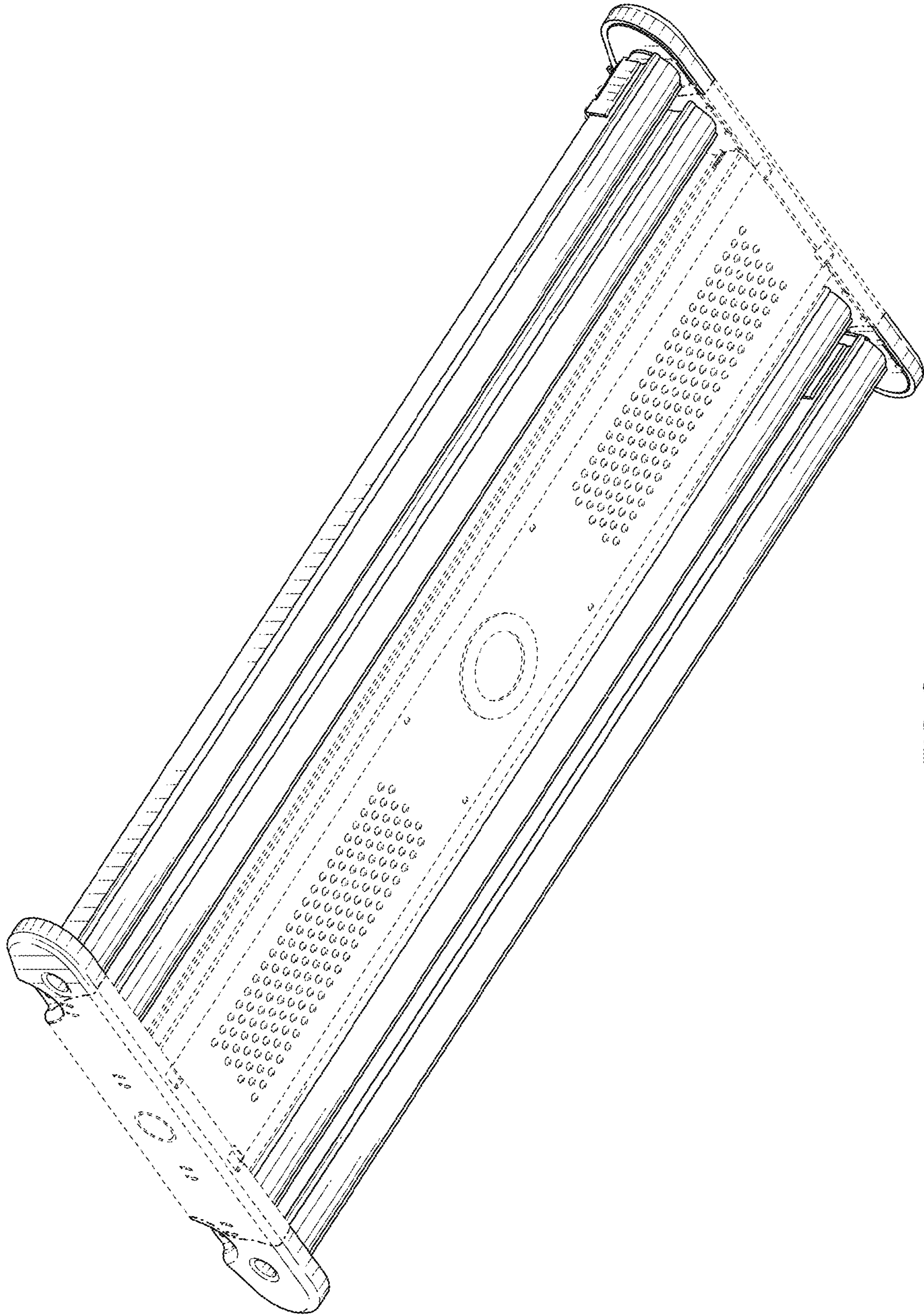

FIG. 2

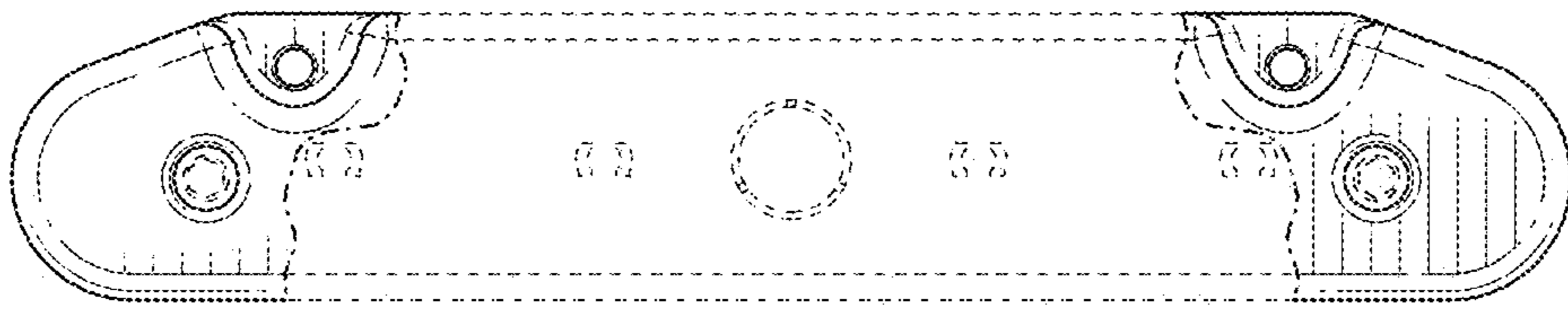

FIG. 3

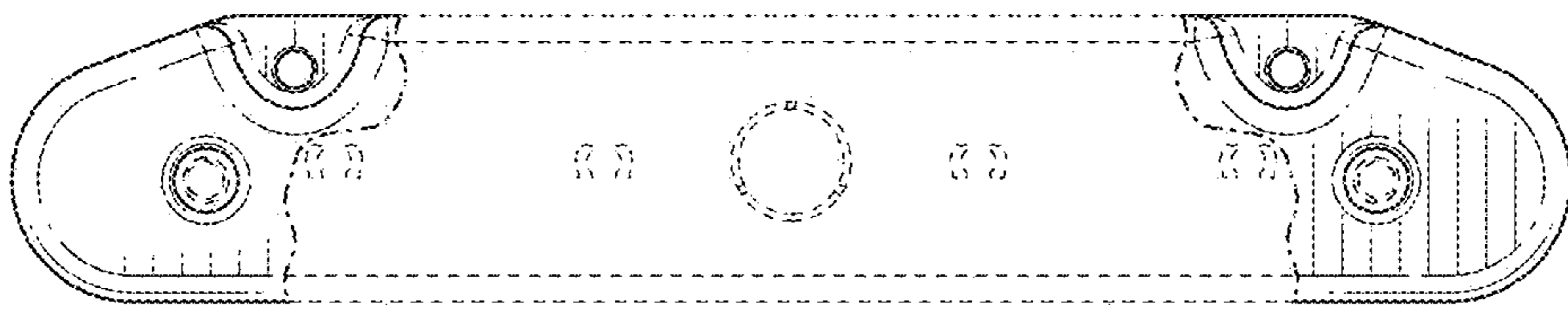

FIG. 4



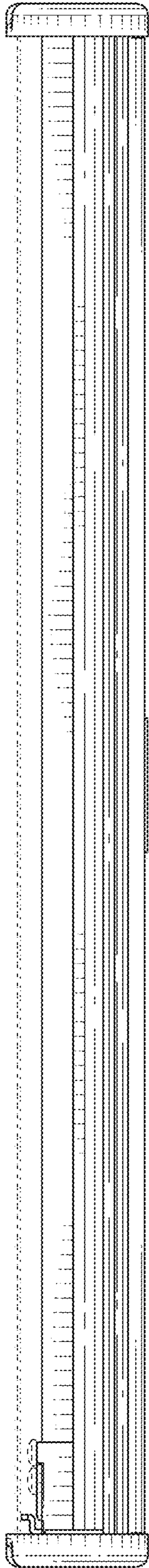

FIG. 5

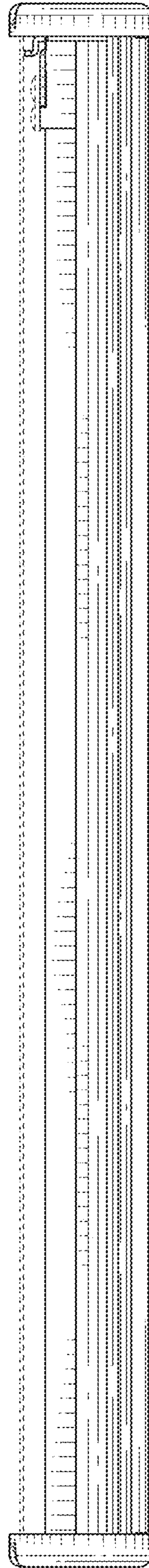

FIG. 6

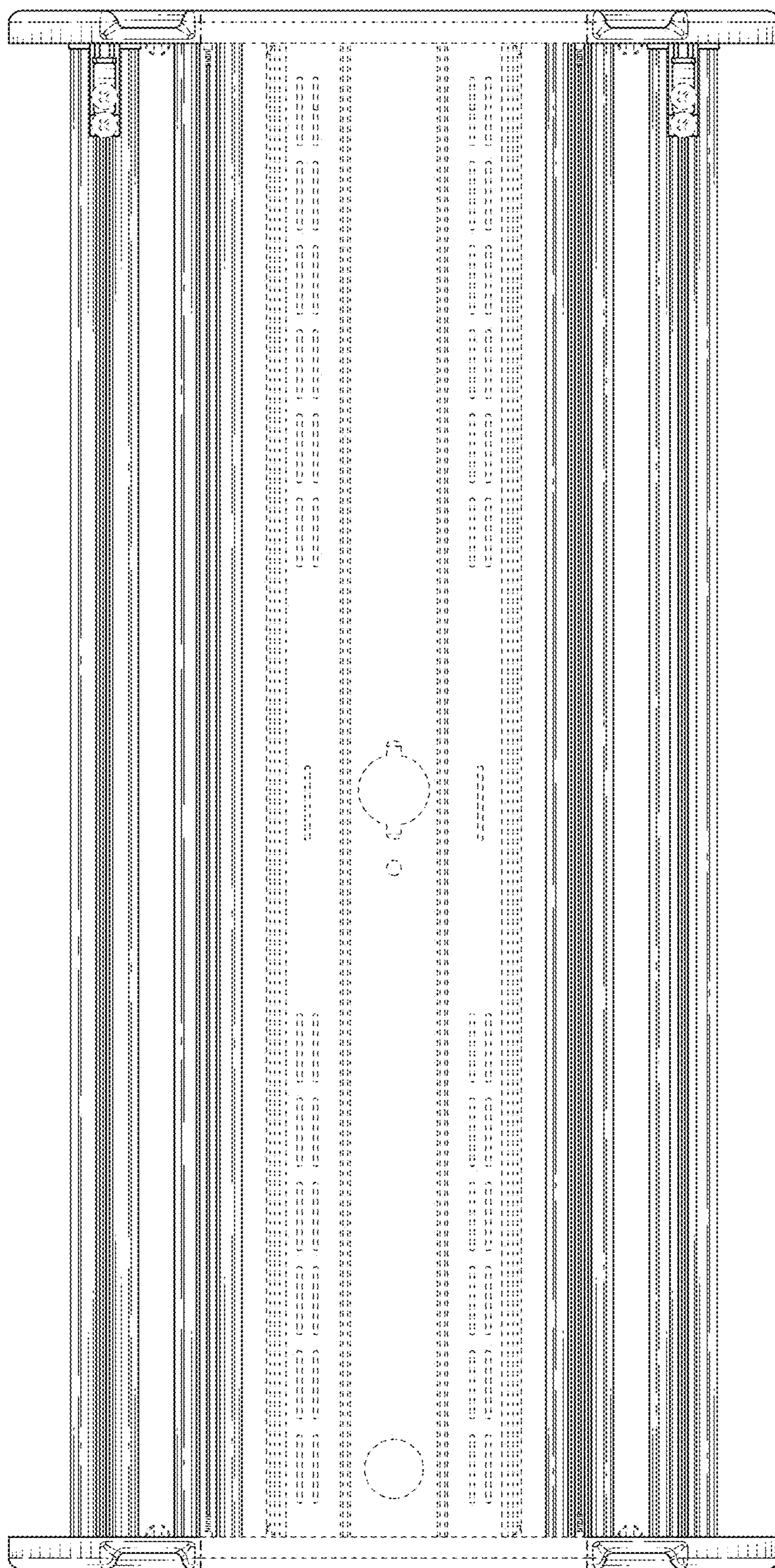

FIG. 7

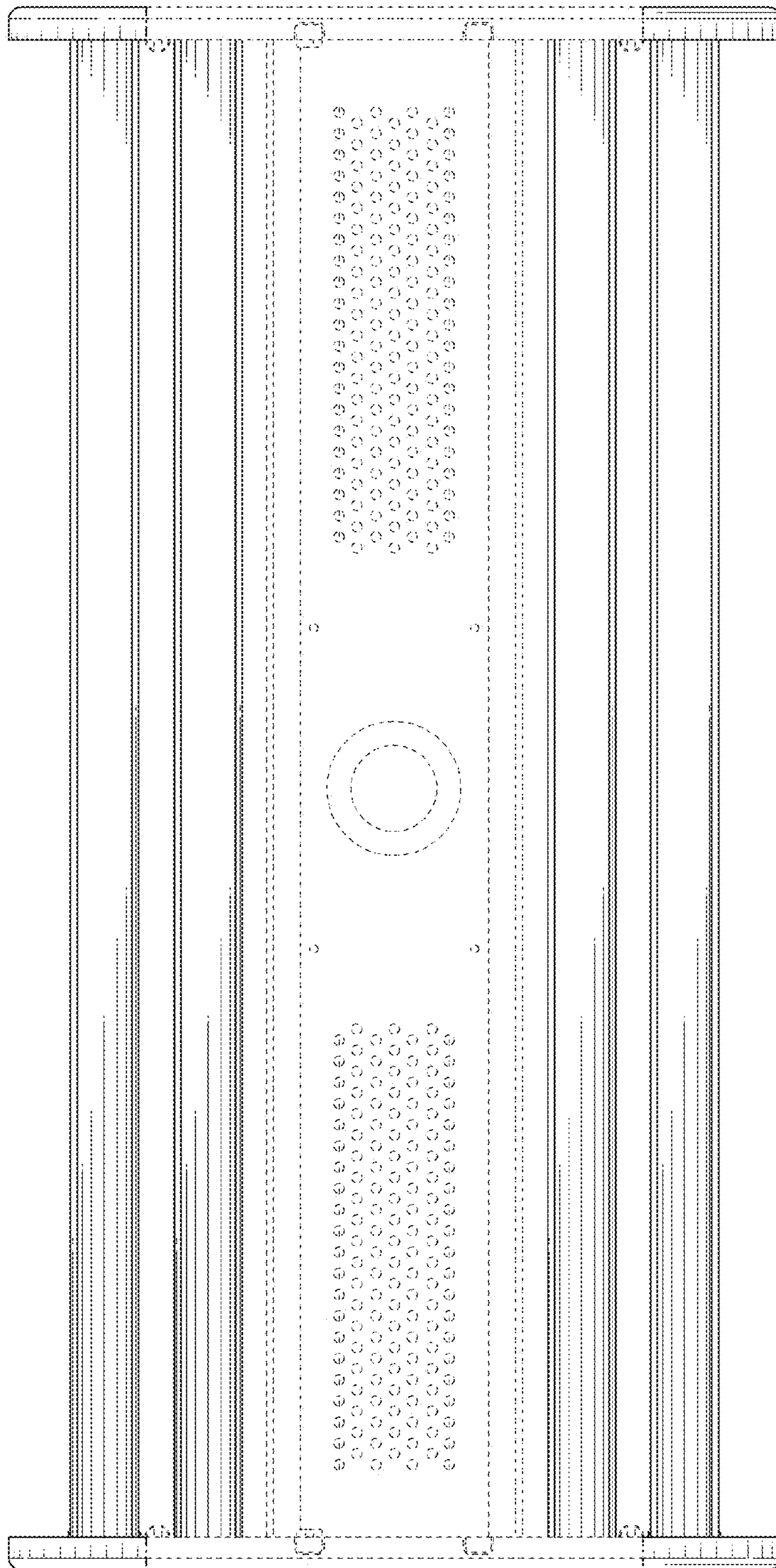

FIG. 8