



US00D904617S

(12) **United States Design Patent** (10) **Patent No.:** **US D904,617 S**
Albertsson et al. (45) **Date of Patent:** **** Dec. 8, 2020**

(54) **PROSTHETIC FOOT**

(57) **CLAIM**

(71) Applicant: **Össur Iceland ehf**, Reykjavik (IS)

The ornamental design for a prosthetic foot, as shown and described.

(72) Inventors: **Aron Kristbjorn Albertsson**, Hafnarfjordur (IS); **Arinbjörn Viggo Clausen**, Reykjavik (IS); **Christophe Guy Lecomte**, Reykjavik (IS)

DESCRIPTION

(73) Assignee: **Össur Iceland ehf**, Reykjavik (IS)

(**) Term: **15 Years**

(21) Appl. No.: **29/662,874**

(22) Filed: **Sep. 10, 2018**

(51) **LOC (12) Cl.** **24-03**

(52) **U.S. Cl.**
USPC **D24/155**

(58) **Field of Classification Search**
USPC **D24/155**

(Continued)

(56) **References Cited**

U.S. PATENT DOCUMENTS

3,920,610 A 11/1975 Wagner
4,645,509 A 2/1987 Poggi et al.
(Continued)

FOREIGN PATENT DOCUMENTS

JP 2018000627 1/2018

OTHER PUBLICATIONS

Imasen Engineering Corporation, "Lapoc System Prostheses" 2009 (4 pages).

(Continued)

Primary Examiner — Charles D Hanson

(74) *Attorney, Agent, or Firm* — Knobbe, Martens, Olson & Bear, LLP

FIG. 1 is a perspective view of a first embodiment of a prosthetic foot embodying the new design; FIG. 2 is a front view thereof; FIG. 3 is a rear view thereof; FIG. 4 is a right side view thereof; FIG. 5 is a left side view thereof; FIG. 6 is a top view thereof; and FIG. 7 is a bottom view thereof. FIG. 8 is a perspective view of a second embodiment of a prosthetic foot embodying the new design; FIG. 9 is a front view thereof; FIG. 10 is a rear view thereof; FIG. 11 is a right side view thereof; FIG. 12 is a left side view thereof; FIG. 13 is a top view thereof; and FIG. 14 is a bottom view thereof. FIG. 15 is a perspective view of a third embodiment of a prosthetic foot embodying the new design; FIG. 16 is a front view thereof; FIG. 17 is a rear view thereof; FIG. 18 is a right side view thereof; FIG. 19 is a left side view thereof; FIG. 20 is a top view thereof; and FIG. 21 is a bottom view thereof. FIG. 22 is a perspective view of a fourth embodiment of a prosthetic foot embodying the new design; FIG. 23 is a front view thereof; FIG. 24 is a rear view thereof; FIG. 25 is a right side view thereof; FIG. 26 is a left side view thereof; FIG. 27 is a top view thereof; and FIG. 28 is a bottom view thereof. FIG. 29 is a perspective view of a fifth embodiment of a prosthetic foot embodying the new design without environmental structure; FIG. 30 is a front view thereof; FIG. 31 is a rear view thereof;

(Continued)

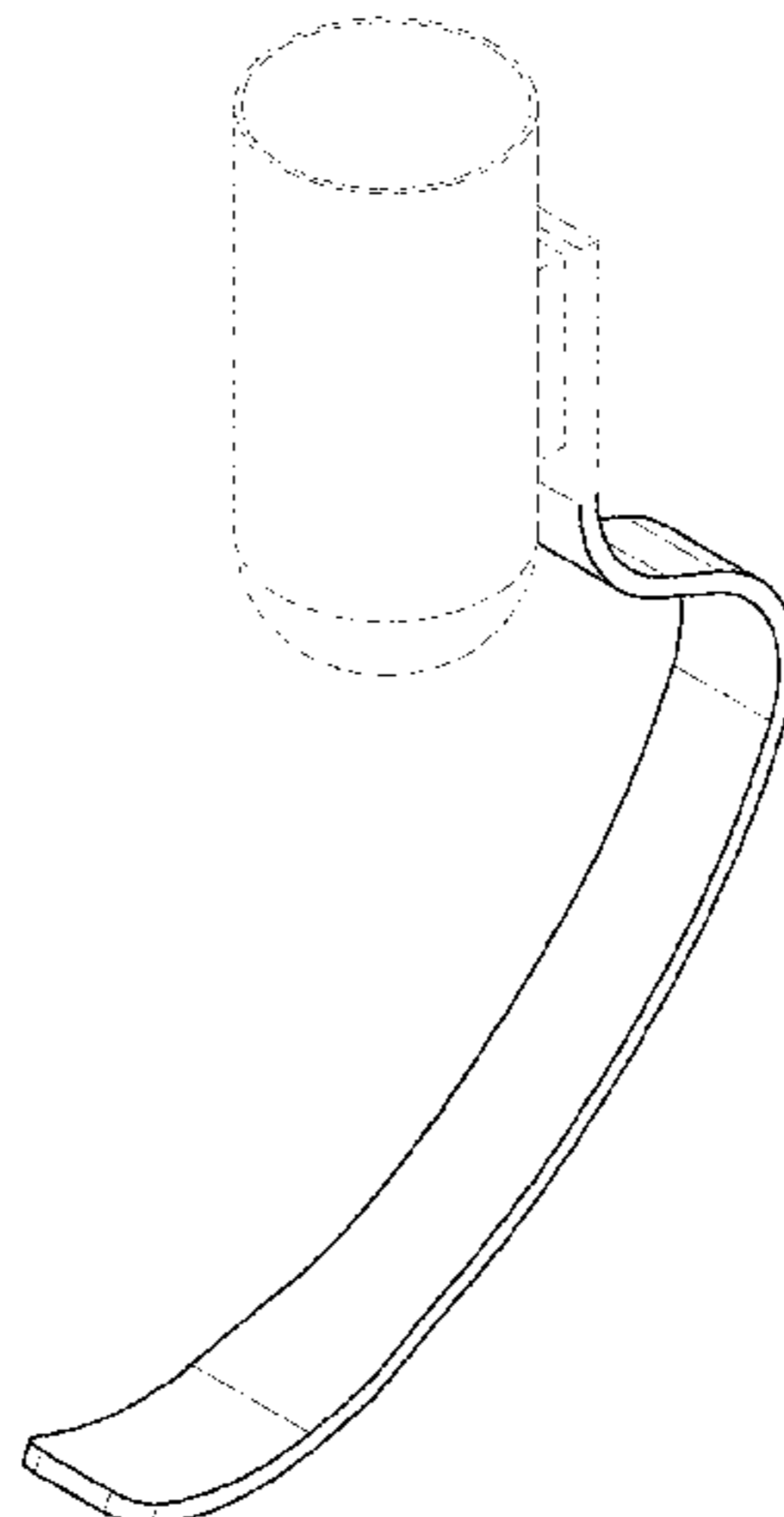

FIG. 32 is a right side view thereof;
 FIG. 33 is a left side view thereof;
 FIG. 34 is a top view thereof; and
 FIG. 35 is a bottom view thereof.
 FIG. 36 is a perspective view of a sixth embodiment of a prosthetic foot embodying the new design without environmental structure;
 FIG. 37 is a front view thereof;
 FIG. 38 is a rear view thereof;
 FIG. 39 is a right side view thereof;
 FIG. 40 is a left side view thereof;
 FIG. 41 is a top view thereof; and
 FIG. 42 is a bottom view thereof.
 FIG. 43 is a perspective view of a seventh embodiment of a prosthetic foot embodying the new design without environmental structure;
 FIG. 44 is a front view thereof;
 FIG. 45 is a rear view thereof;
 FIG. 46 is a right side view thereof;
 FIG. 47 is a left side view thereof;
 FIG. 48 is a top view thereof; and
 FIG. 49 is a bottom view thereof.
 FIG. 50 is a perspective view of an eighth embodiment of a prosthetic foot embodying the new design without environmental structure;
 FIG. 51 is a front view thereof;
 FIG. 52 is a rear view thereof;
 FIG. 53 is a right side view thereof;
 FIG. 54 is a left side view thereof;
 FIG. 55 is a top view thereof; and,
 FIG. 56 is a bottom view thereof.
 Broken lines are used to illustrate portions of the prosthetic foot that form no part of the claimed design.

1 Claim, 40 Drawing Sheets

(58) **Field of Classification Search**

CPC A61F 2/3859; A61F 2/38; A61F 2/389;
 A61F 2/3886; A61F 2/60; A61F 2/06;
 A61F 2/66; A61F 2/76; A61F 2310/00023
 See application file for complete search history.

(56) **References Cited**

U.S. PATENT DOCUMENTS

4,652,266	A	3/1987	Truesdell
4,822,363	A	4/1989	Phillips
4,994,086	A	2/1991	Edwards
5,062,859	A	11/1991	Naeder
5,066,305	A	11/1991	Firth
5,549,711	A	8/1996	Bryant
5,593,456	A	1/1997	Merlette
5,725,598	A	3/1998	Phillips
6,120,547	A	9/2000	Christensen

6,306,178	B1	10/2001	Kania et al.	
6,514,293	B1	2/2003	Jang et al.	
6,562,075	B2	5/2003	Townsend et al.	
7,172,630	B2	2/2007	Christensen	
7,226,485	B2	6/2007	Townsend et al.	
7,341,603	B2	3/2008	Christensen	
7,364,593	B2	4/2008	Townsend et al.	
7,503,937	B2	3/2009	Asgeirsson et al.	
7,578,852	B2	8/2009	Townsend et al.	
7,708,784	B2	5/2010	Townsend et al.	
7,794,506	B2	9/2010	Christensen	
D632,392	S *	2/2011	Jacobs	D24/155
D633,618	S *	3/2011	Johnson	D24/155
8,007,544	B2	8/2011	Jonsson et al.	
D655,009	S *	2/2012	L'Heureux	D24/155
8,167,956	B2	5/2012	Bonacini	
D661,807	S *	6/2012	Sigurdsson	D24/155
8,323,354	B2	12/2012	Bedard et al.	
8,377,144	B2	2/2013	Jonsson et al.	
8,377,146	B2	2/2013	Jonsson et al.	
8,535,390	B1	9/2013	Lecomte et al.	
D714,939	S *	10/2014	Gunnsteinsson	D24/155
8,858,649	B2	10/2014	Jonsson et al.	
D718,861	S *	12/2014	Halldorsson	D24/155
8,986,397	B2	3/2015	Bedard et al.	
9,017,421	B2 *	4/2015	Lecomte	A61F 2/66 623/53
D731,062	S *	6/2015	Meyer	D24/155
9,044,346	B2	6/2015	Langlois et al.	
9,084,689	B2	7/2015	Herr	
9,149,371	B2	10/2015	Karlsson et al.	
9,668,886	B2	6/2017	Mackiewicz et al.	
D797,292	S *	9/2017	Clausen	A61F 2/66 D24/155
2007/0100465	A1 *	5/2007	Egan	B32B 5/28 623/52
2009/0204231	A1 *	8/2009	Bonacini	A61F 2/76 623/55
2010/0042228	A1 *	2/2010	Doddroe	A61F 2/6607 623/55
2012/0055616	A1	3/2012	Clausen	
2015/0209160	A1	7/2015	Clausen et al.	
2015/0374514	A1 *	12/2015	Clausen	A61F 2/66 623/53
2017/0049585	A1	2/2017	Boiten et al.	

OTHER PUBLICATIONS

Xiborg, "Xibotg Genesis" 2014-2018 (3 pages).
 Cheetah® Xtend™, <https://web.archive.org/web/20170320170156/http://www.ossur.com:80/prosthetic-solutions/products/sport-solutions/cheetah-xtend>, available before Sep. 10, 2018.
 Cheetah® Xtreme™, <https://web.archive.org/web/20170320170240/http://www.ossur.com:80/prosthetic-solutions/products/sport-solutions/cheetah-xtreme>, available before Sep. 10, 2018.
 Flex-Foot Cheetah®, <https://web.archive.org/web/20180807143737/https://www.ossur.com/prosthetic-solutions/products/sport-solutions/cheetah>, available before Sep. 10, 2018.
 Flex-Run™, <https://web.archive.org/web/20170319234155/http://www.ossur.com:80/prosthetic-solutions/products/sport-solutions/flex-run>, available before Sep. 10, 2018.

* cited by examiner

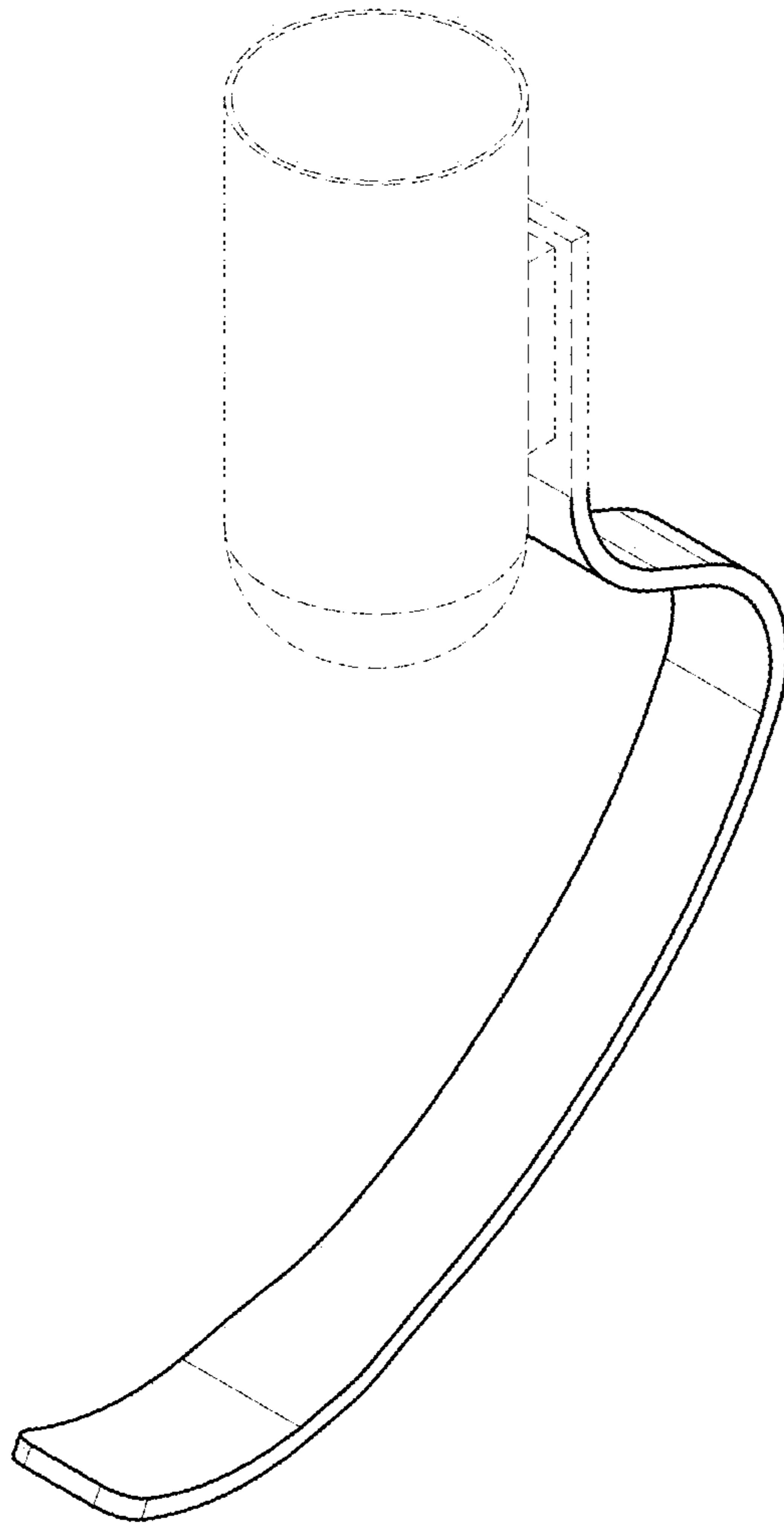

FIG. 1

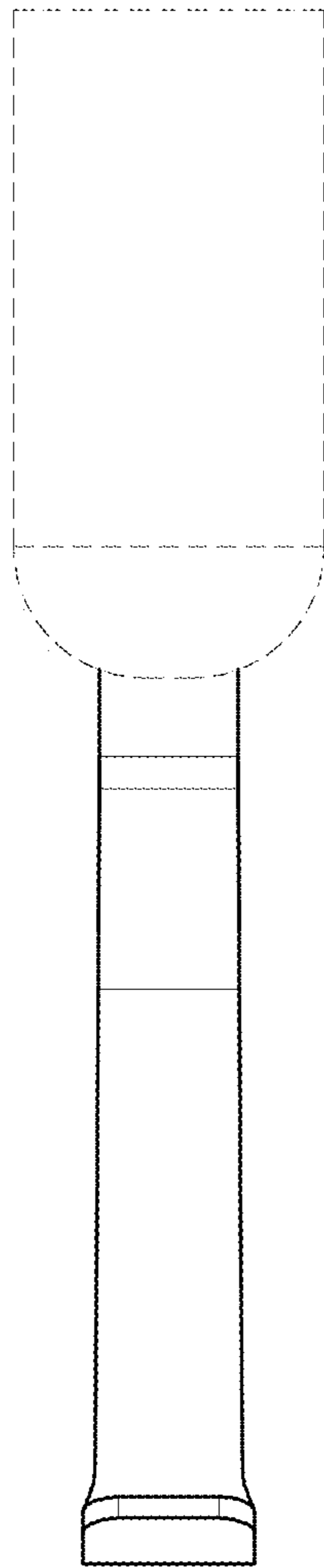

FIG. 2

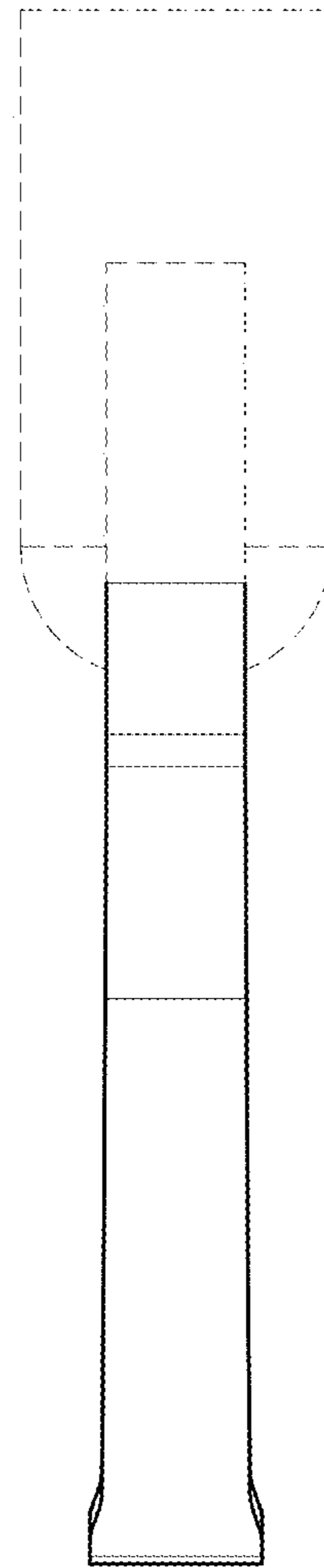

FIG. 3

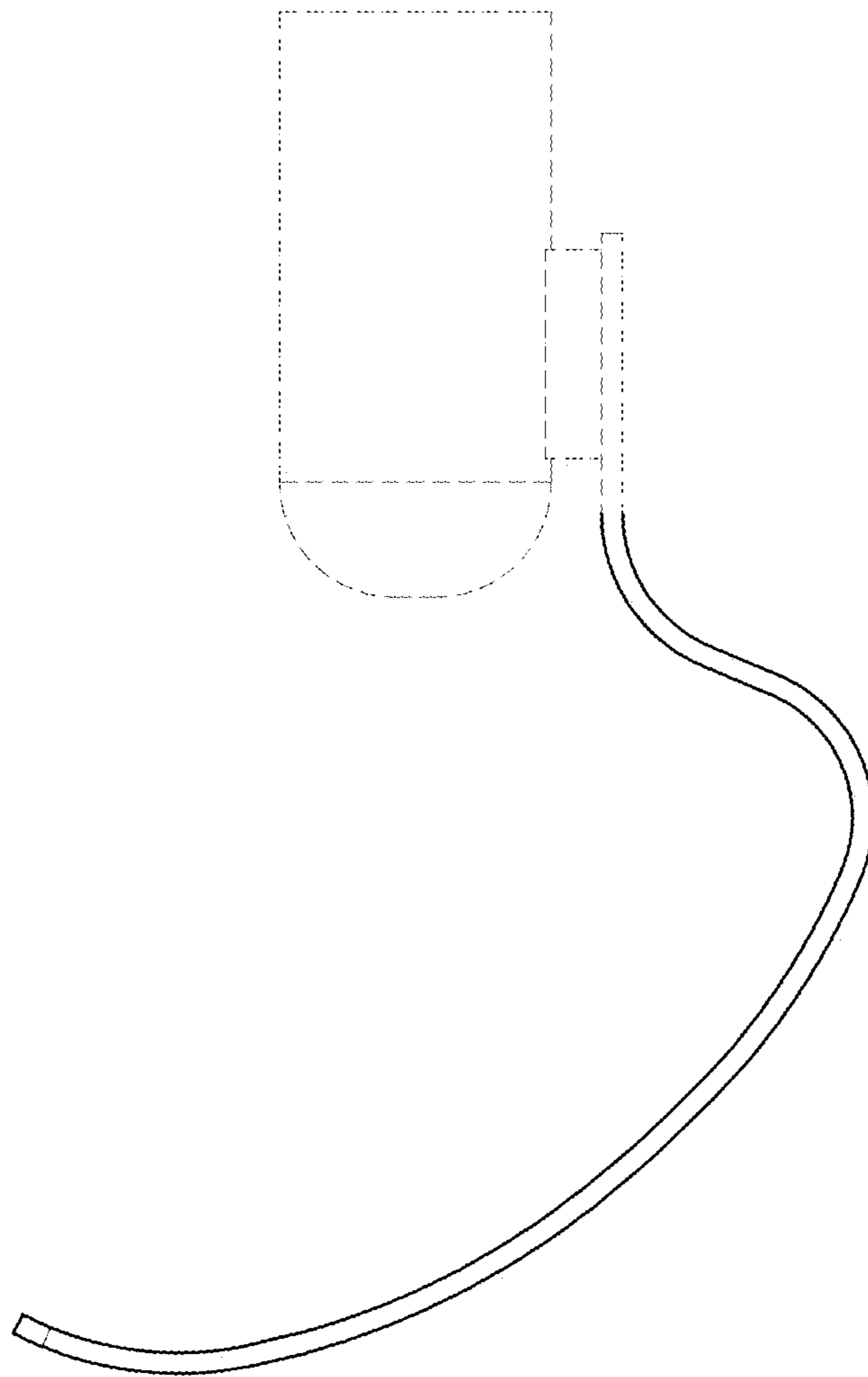

FIG. 4

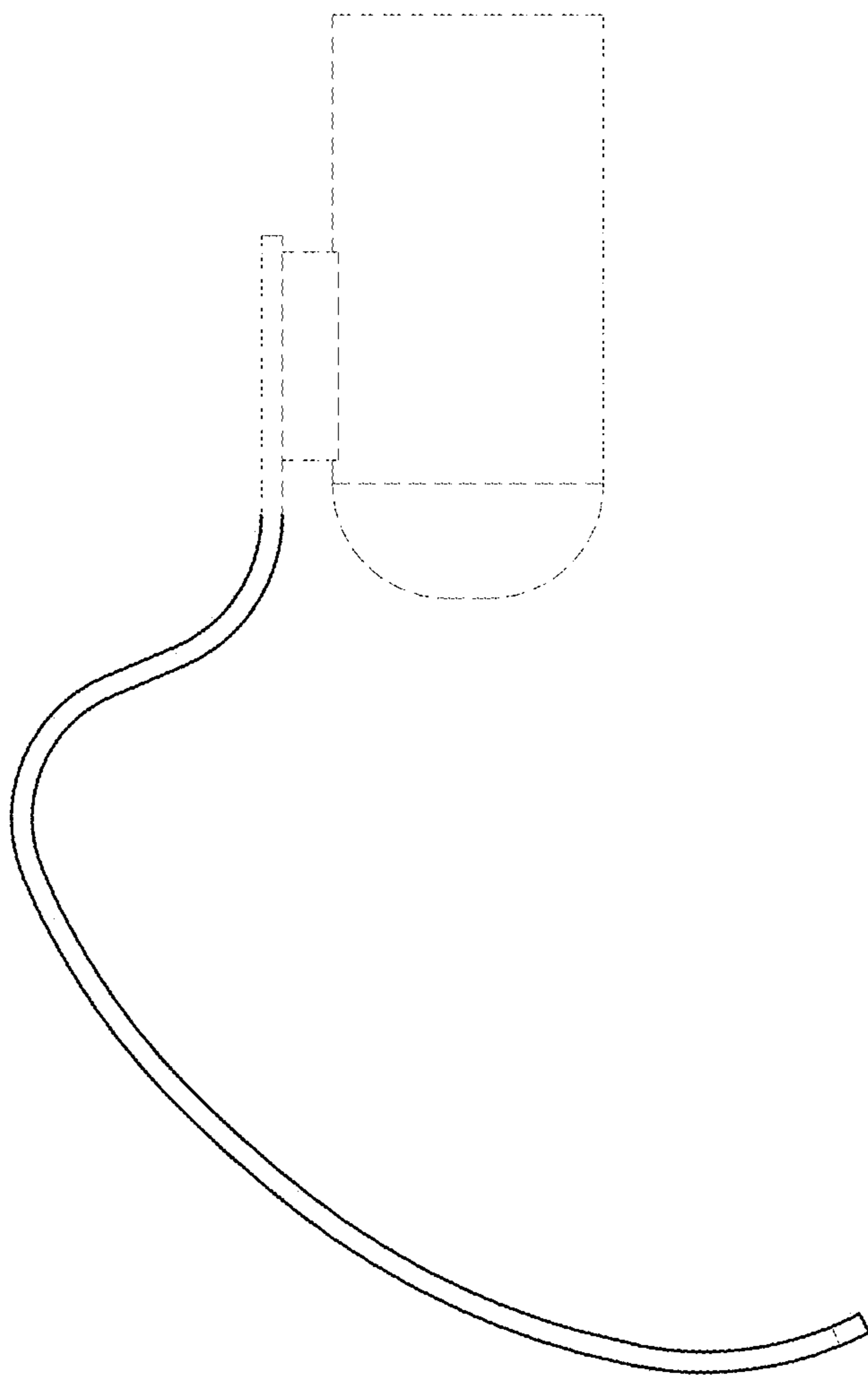

FIG. 5

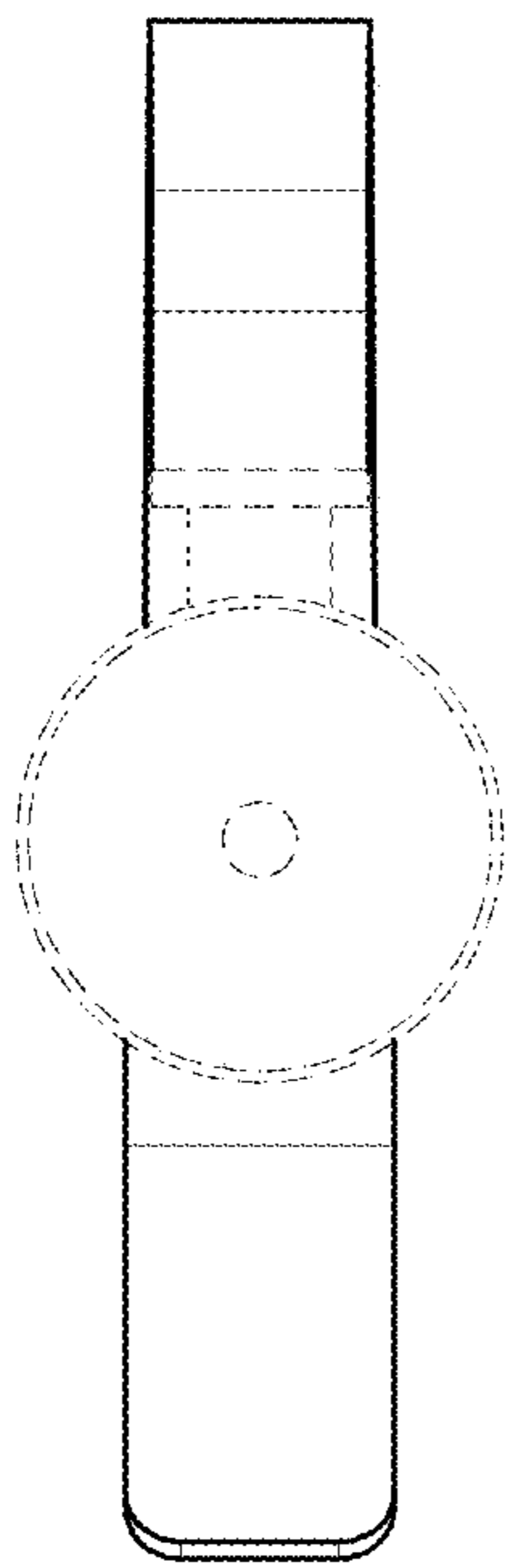

FIG. 6

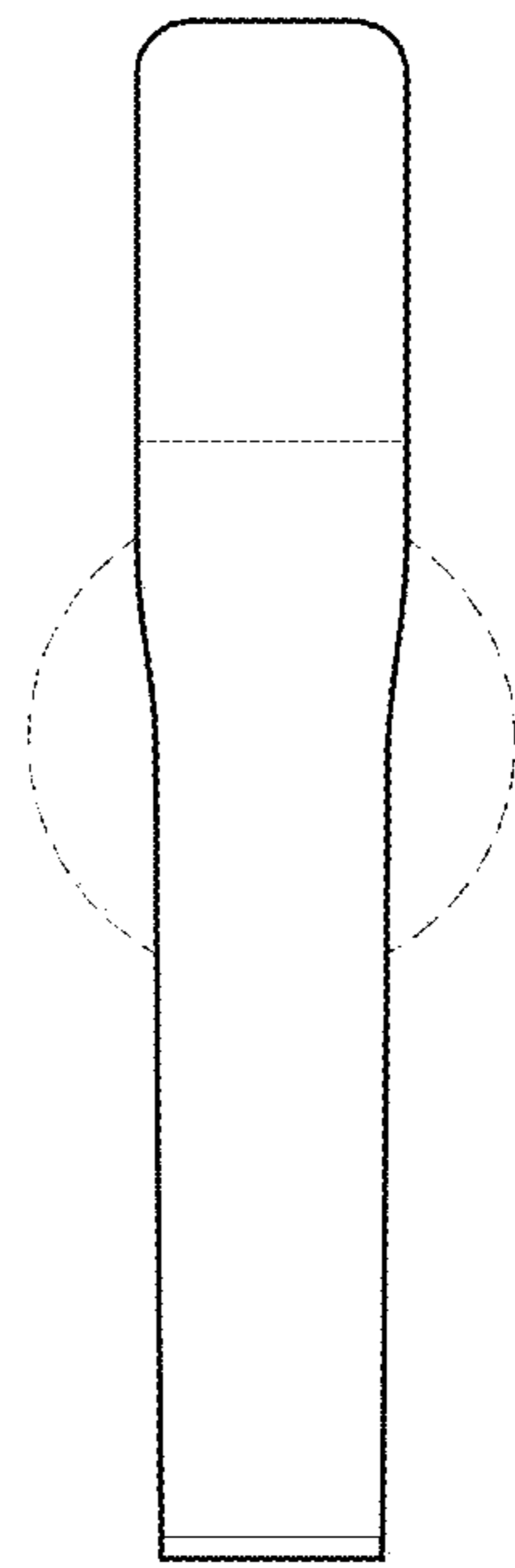

FIG. 7

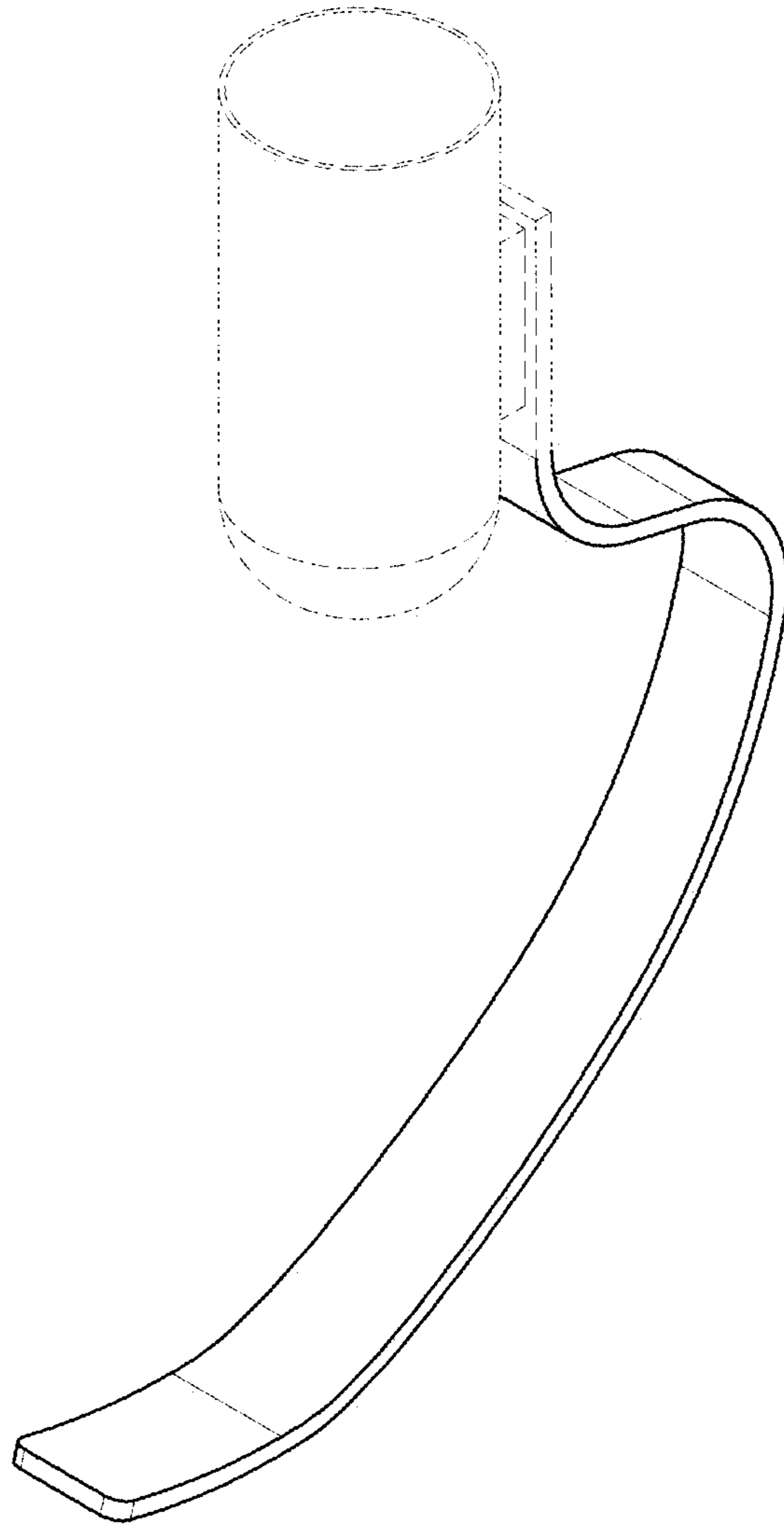

FIG. 8

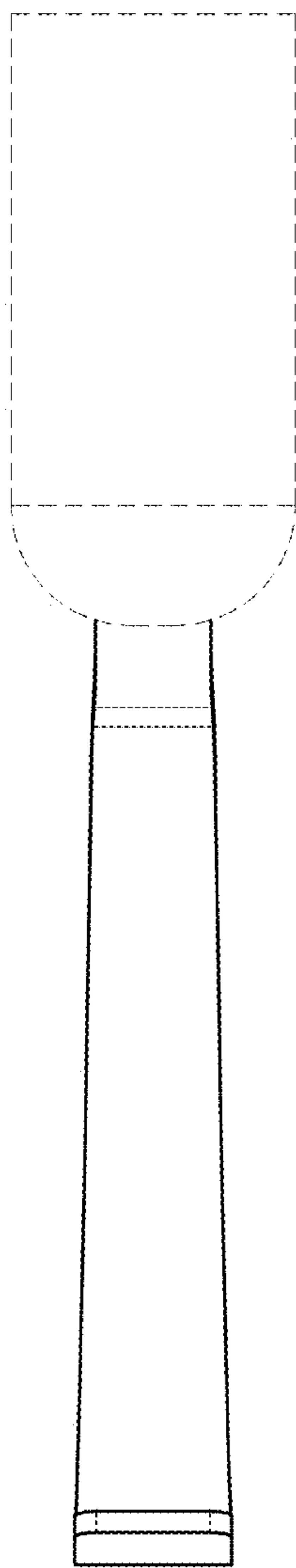

FIG. 9

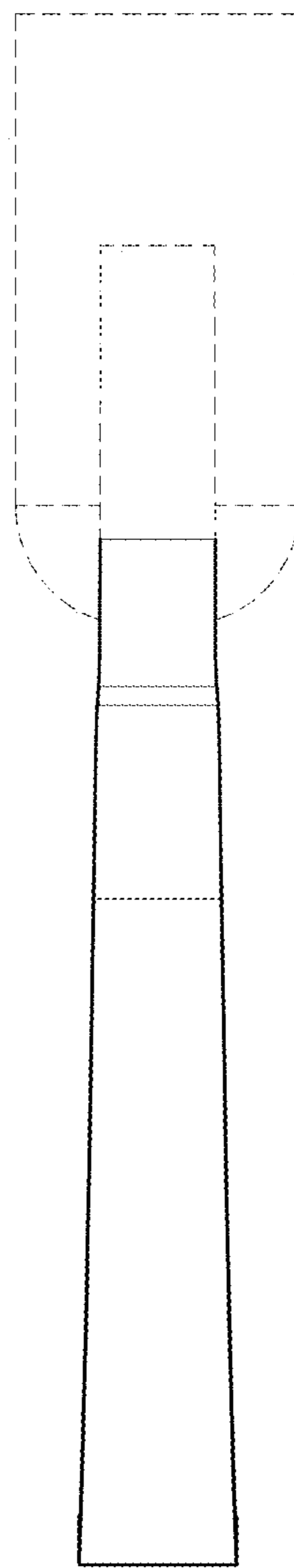

FIG. 10

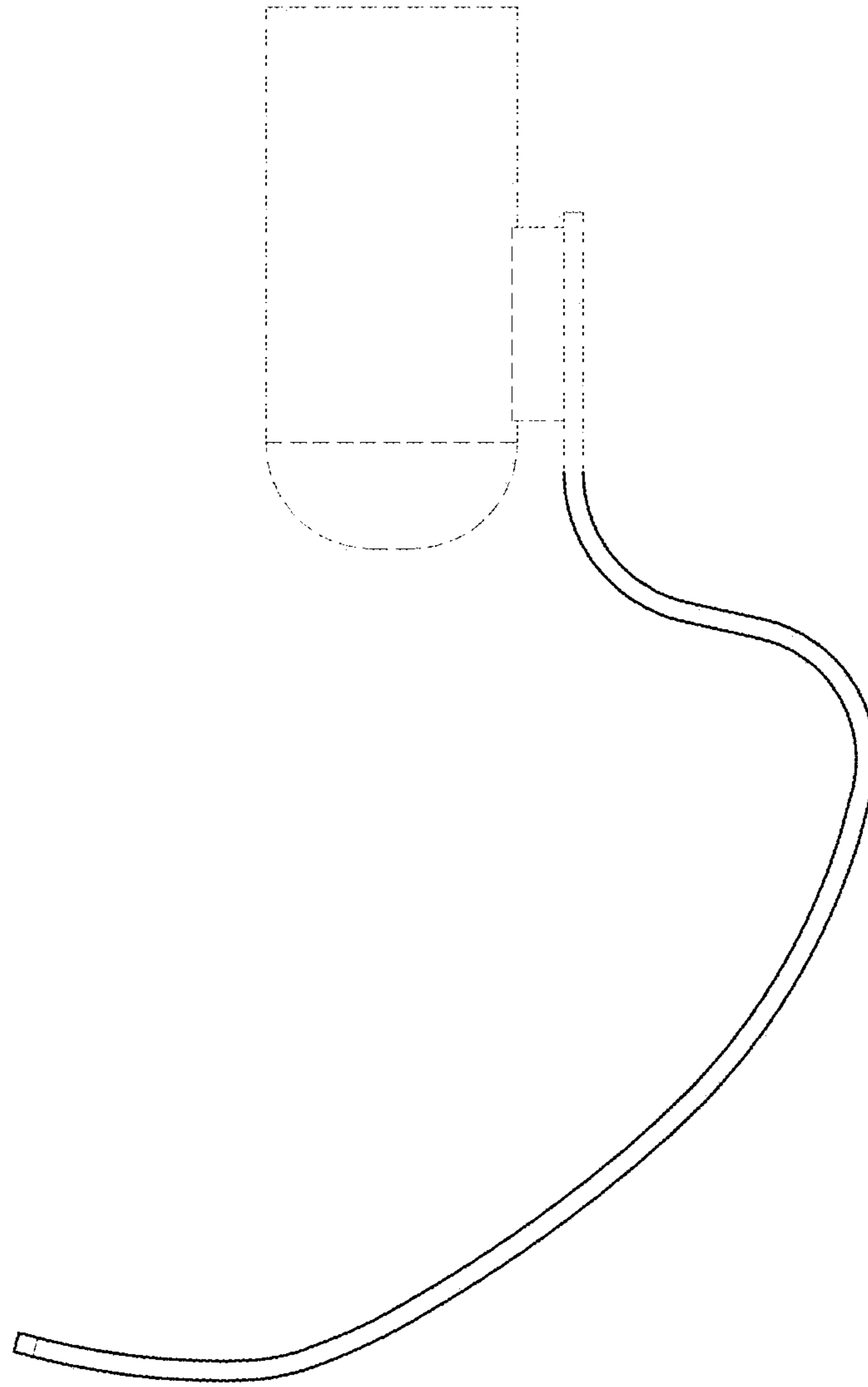

FIG. 11

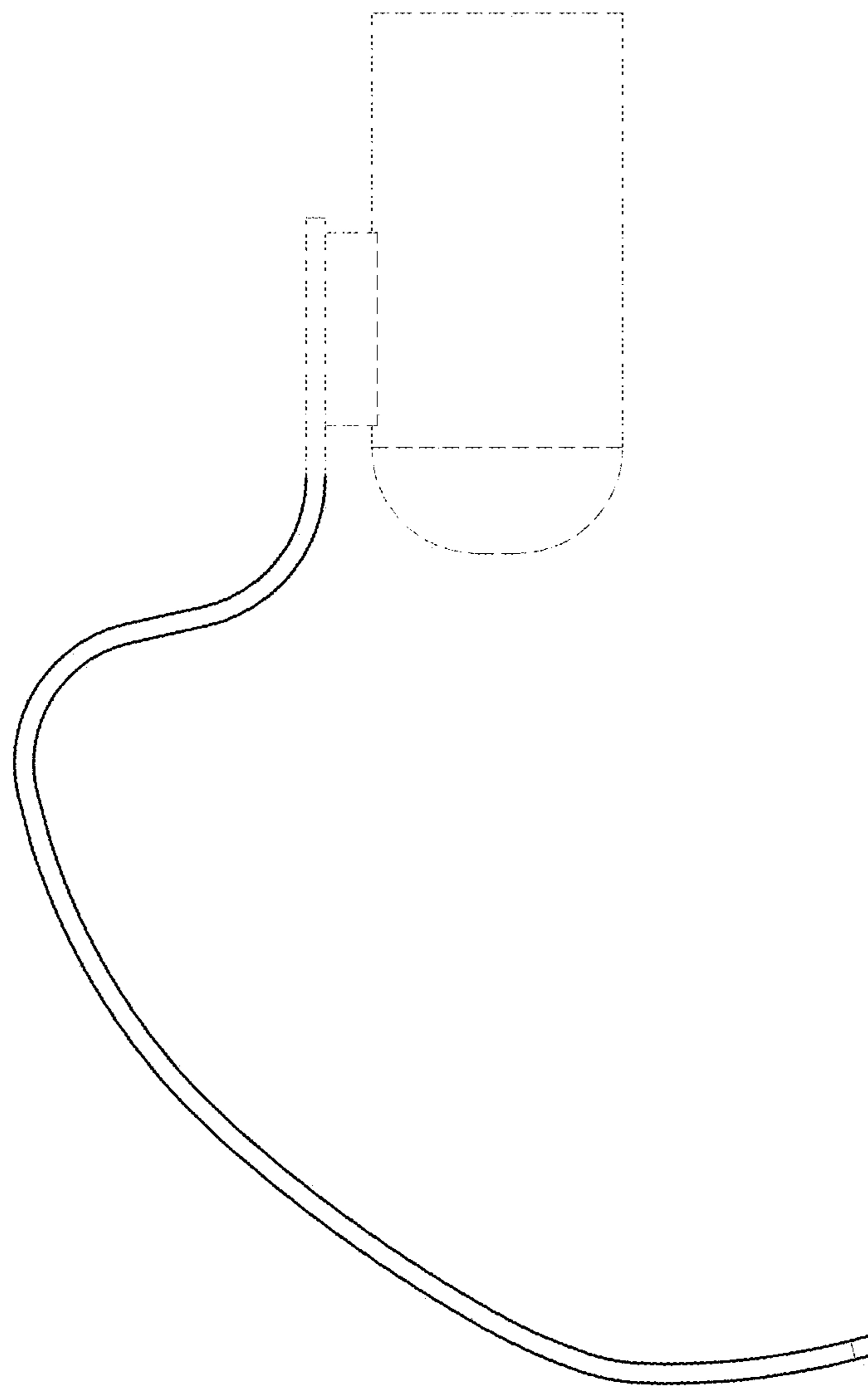

FIG. 12

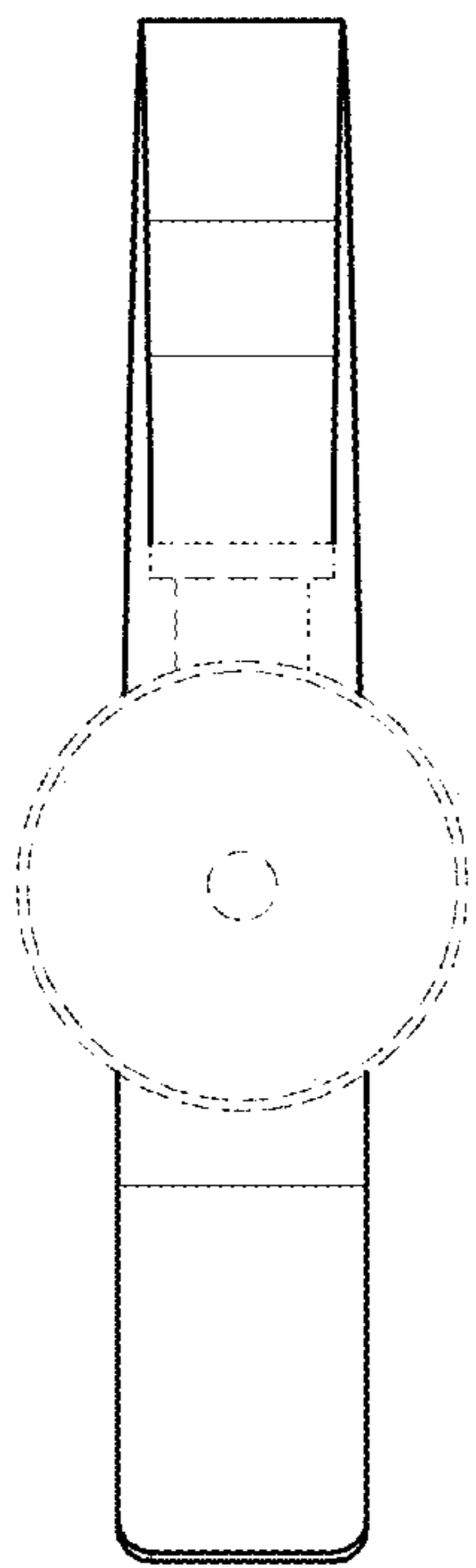

FIG. 13

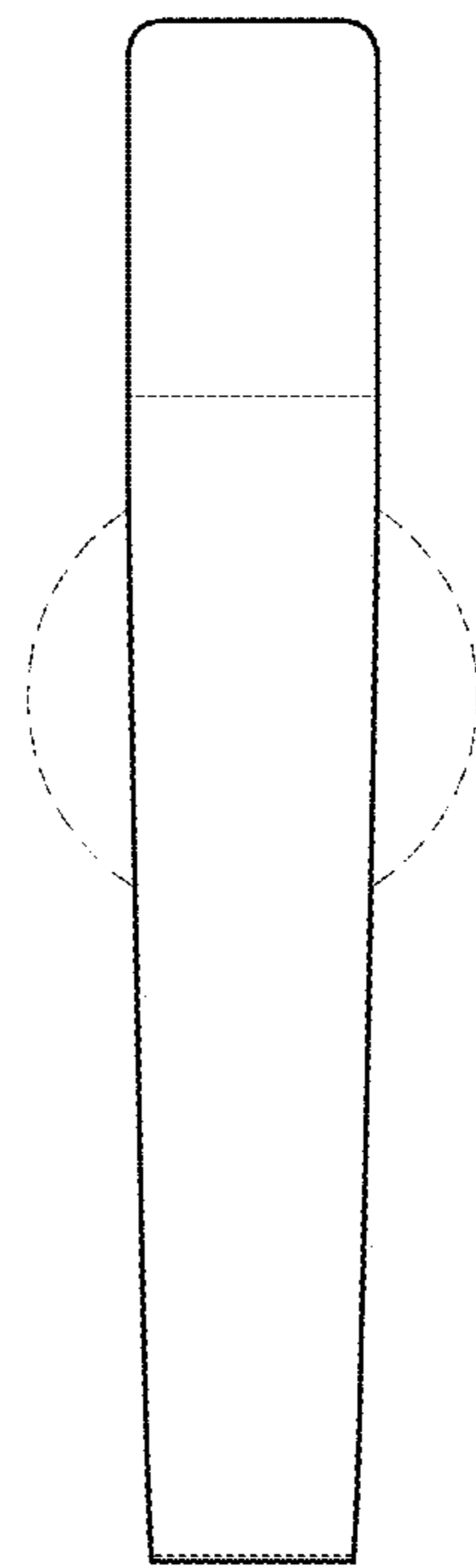

FIG. 14

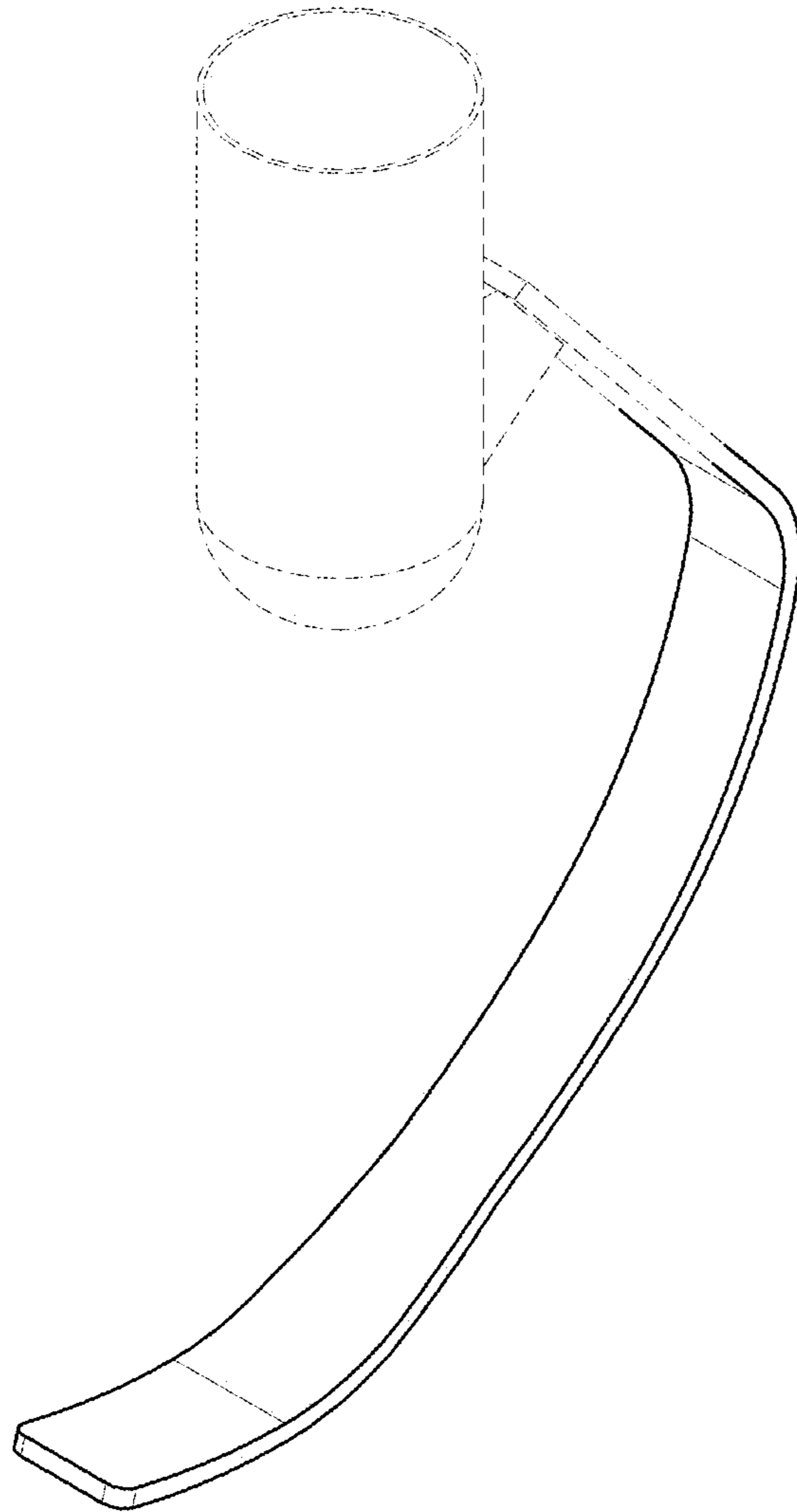

FIG. 15

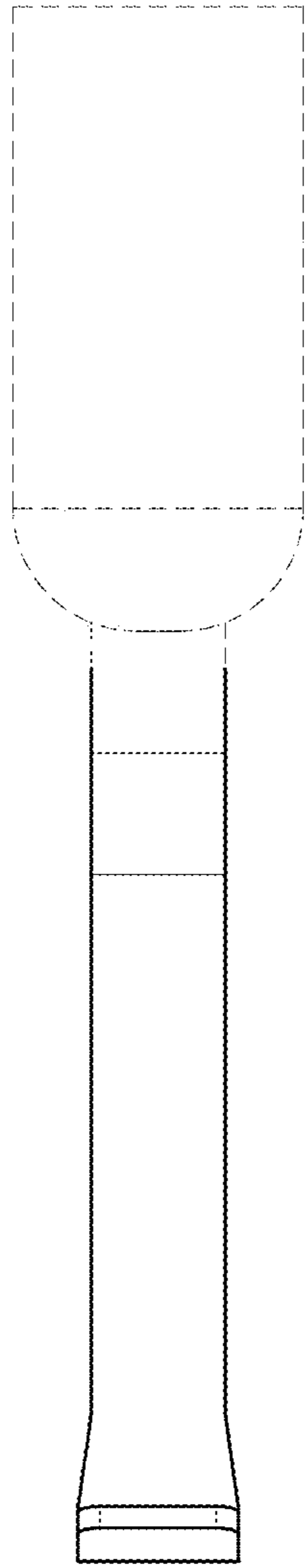

FIG. 16

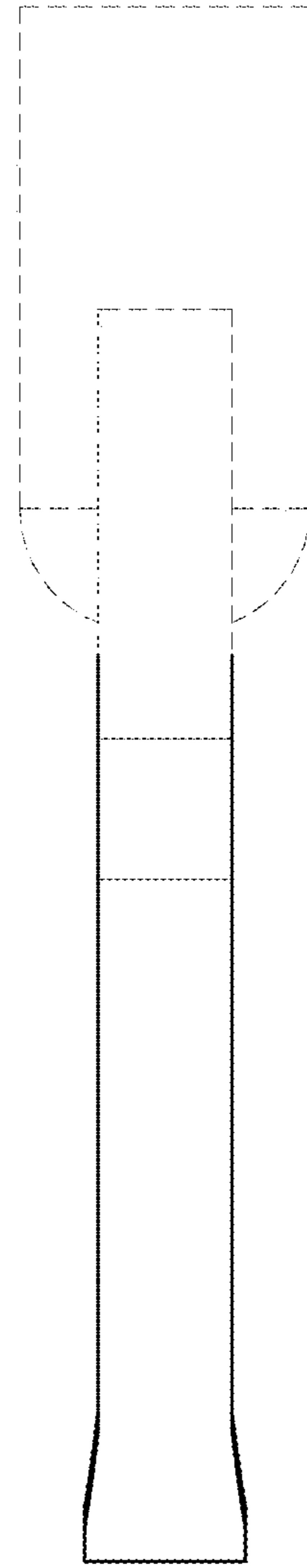

FIG. 17

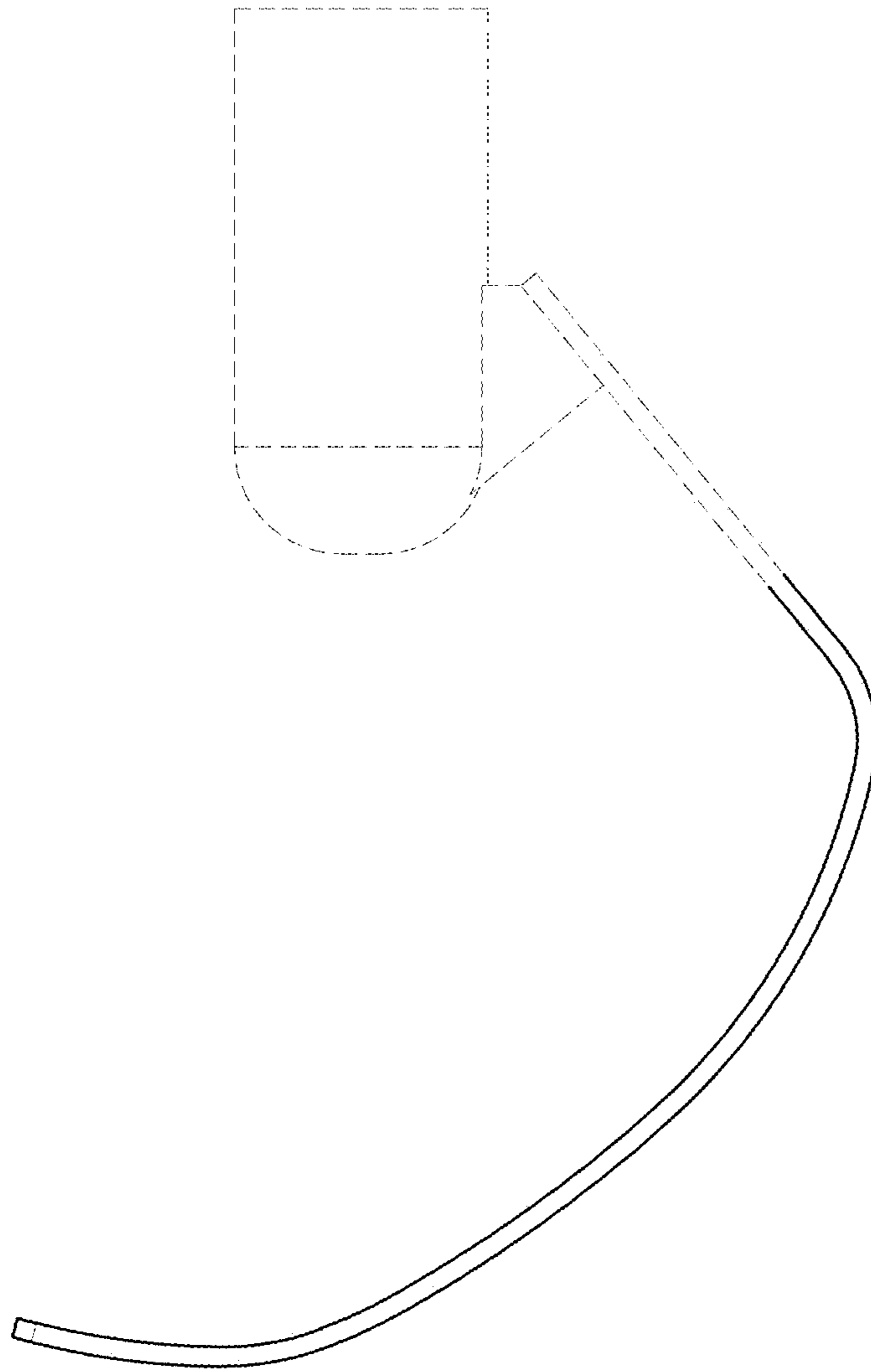

FIG. 18

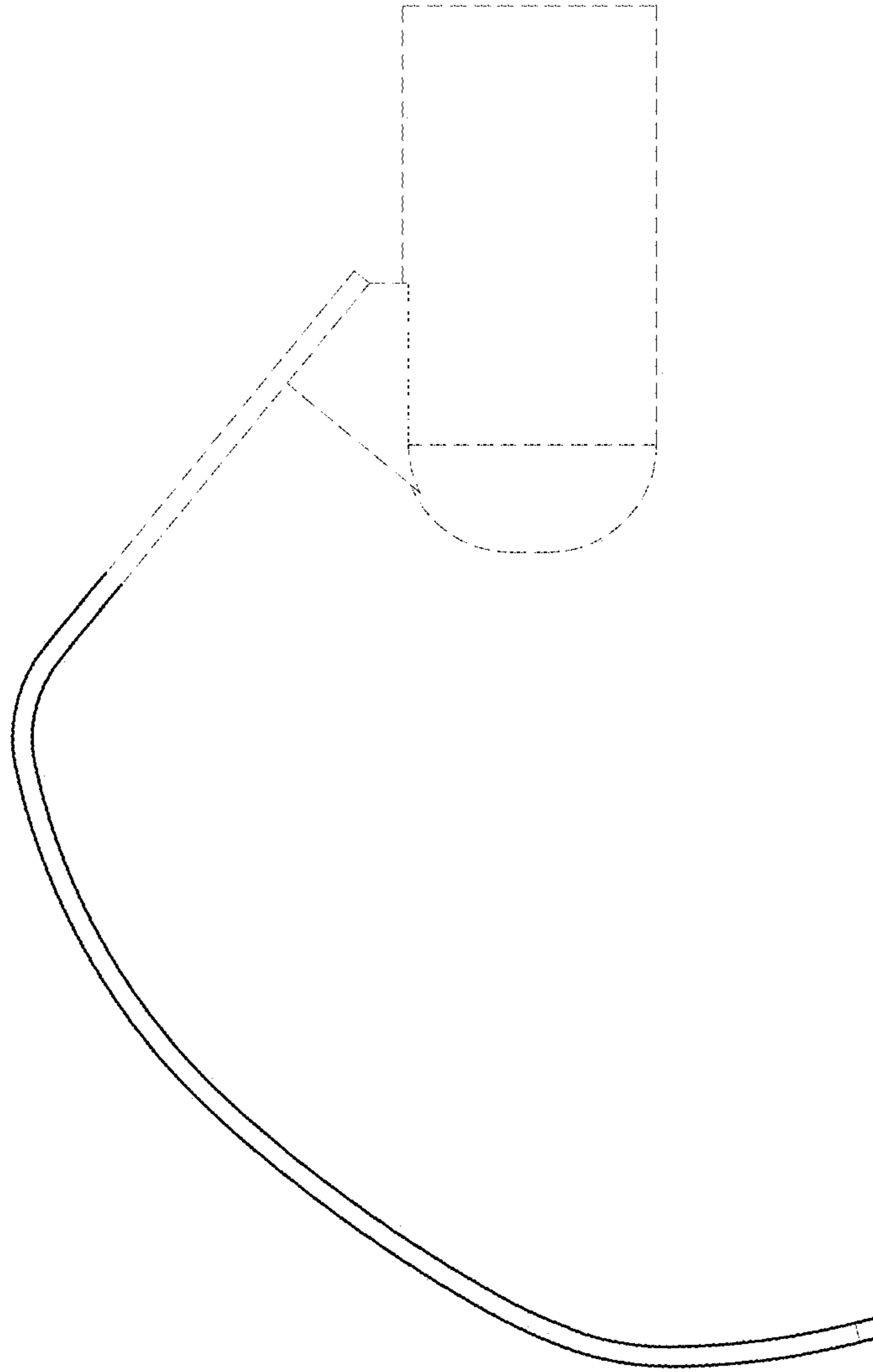

FIG. 19

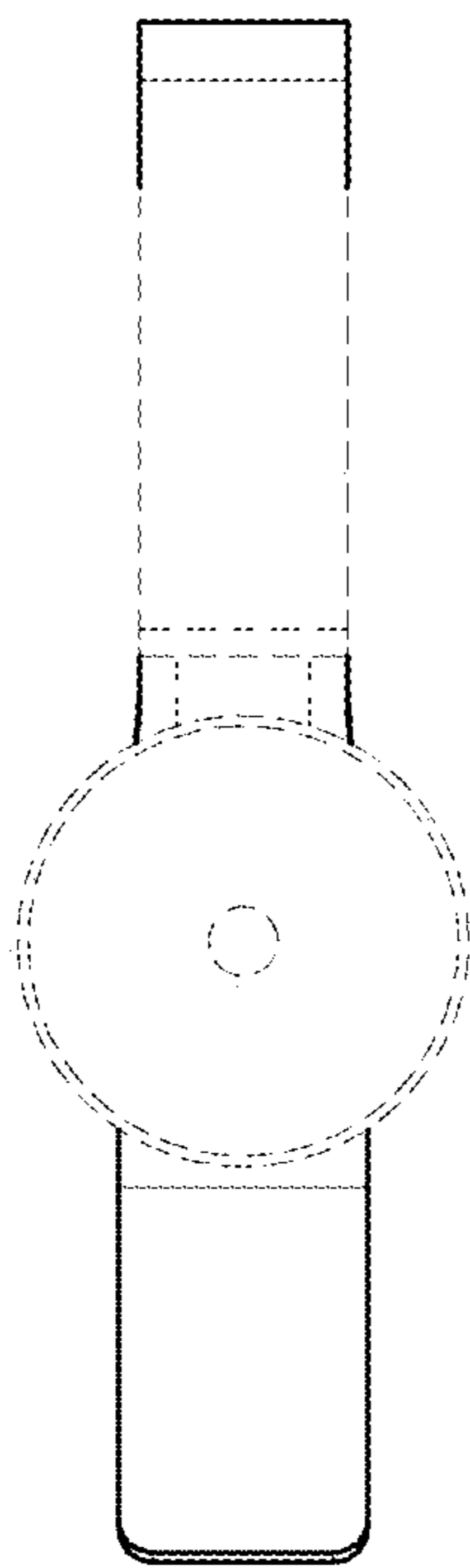

FIG. 20

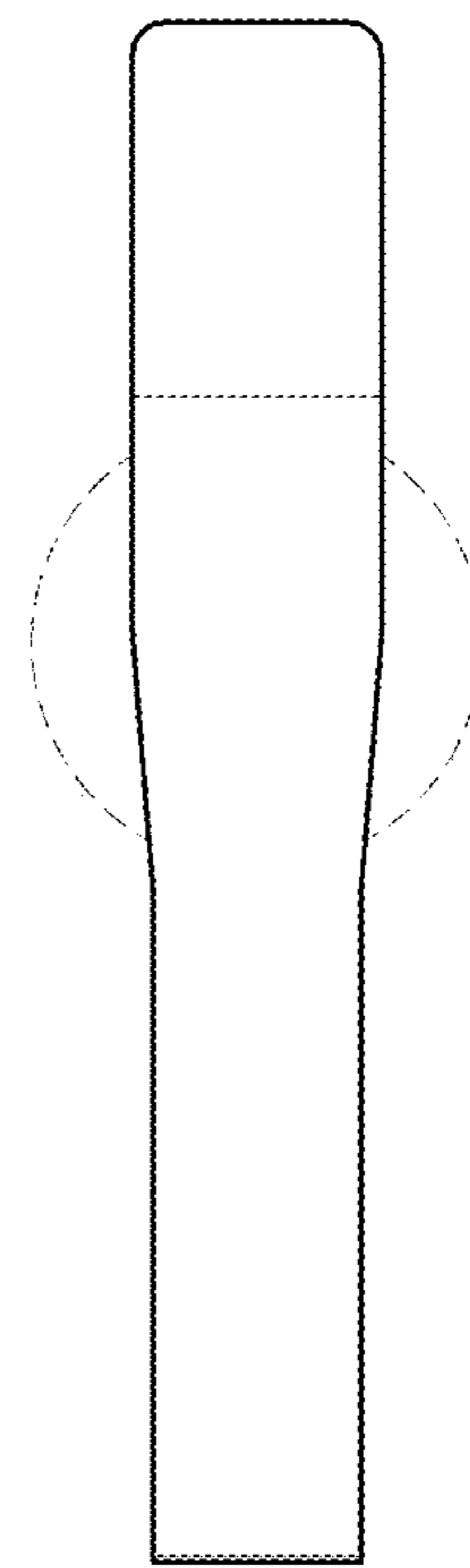

FIG. 21

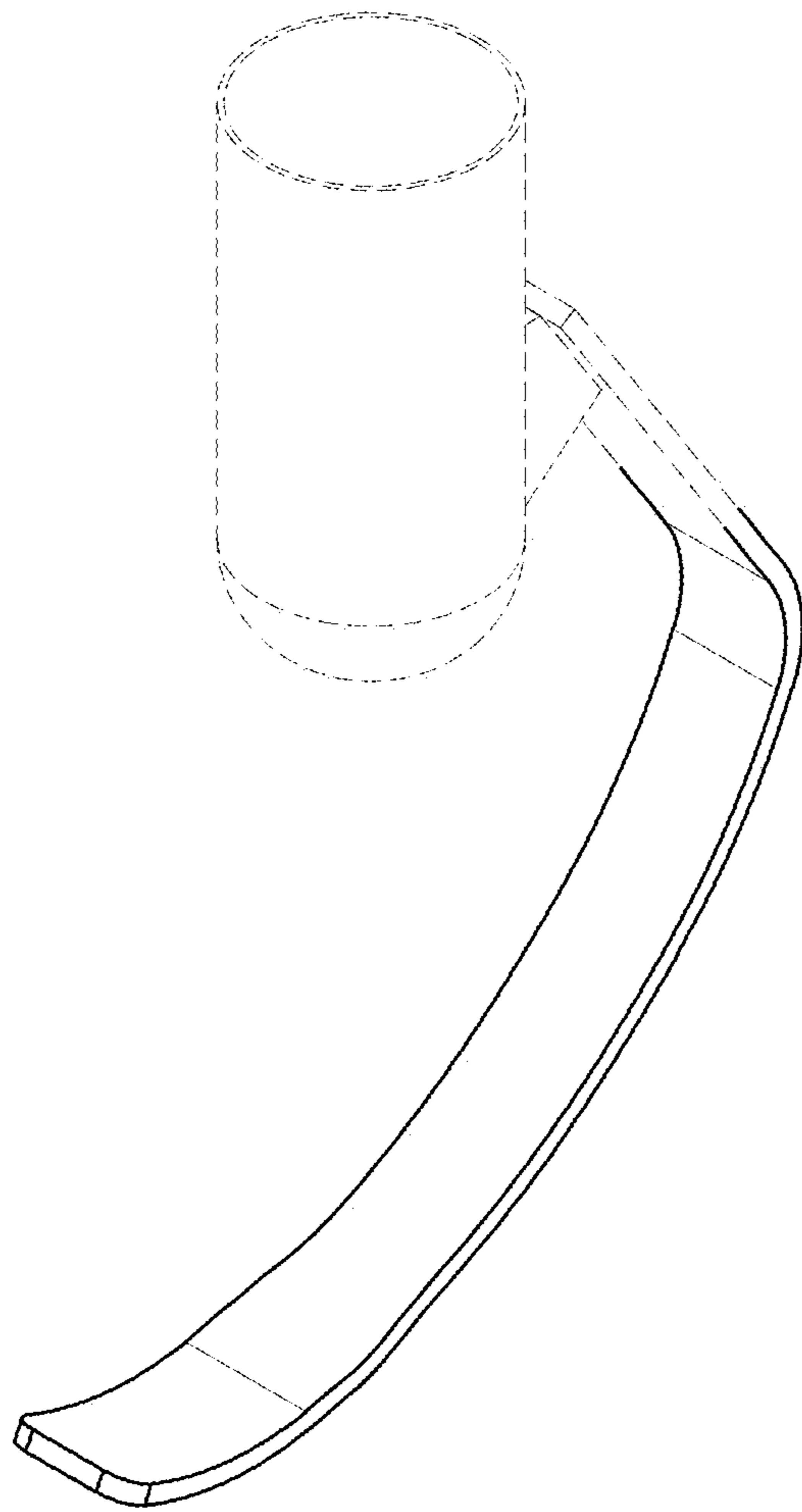

FIG. 22

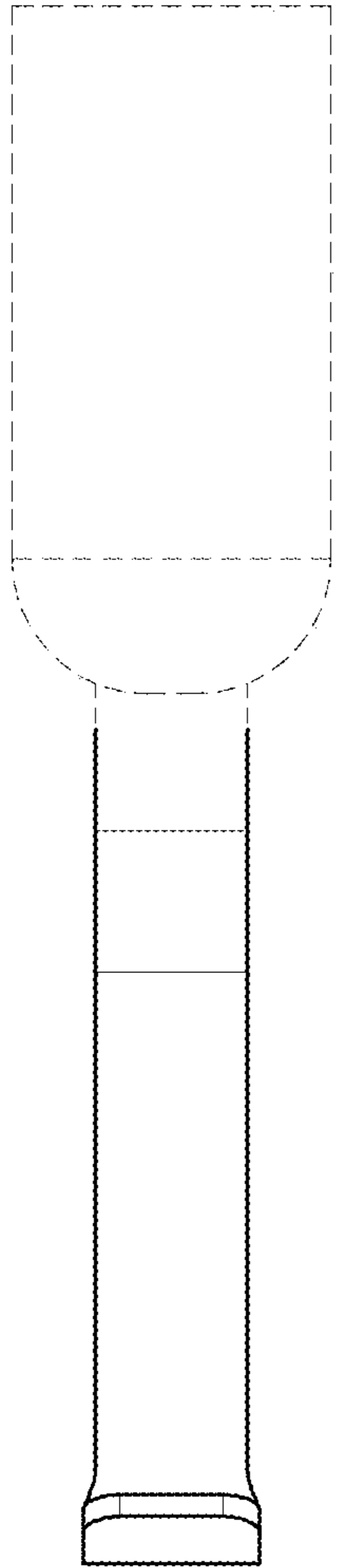

FIG. 23

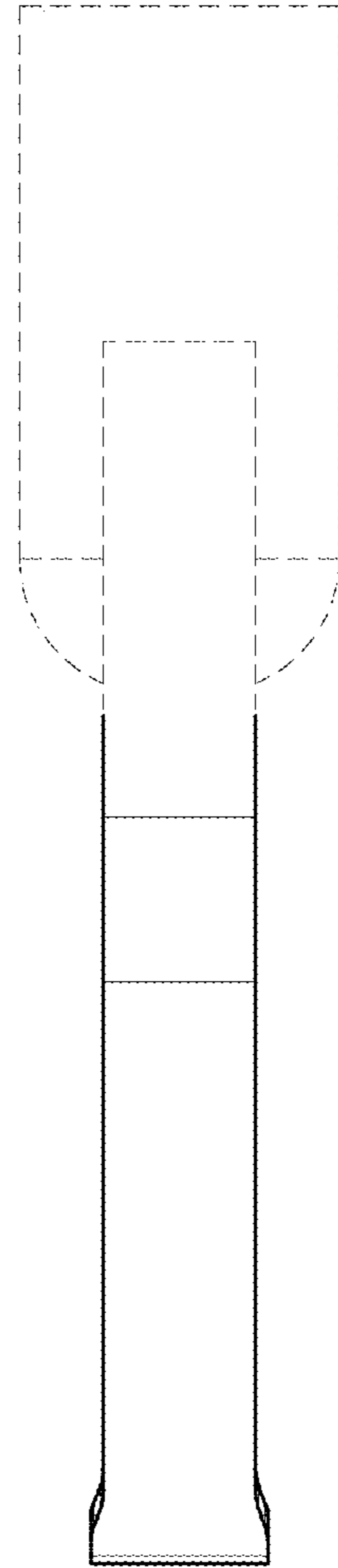

FIG. 24

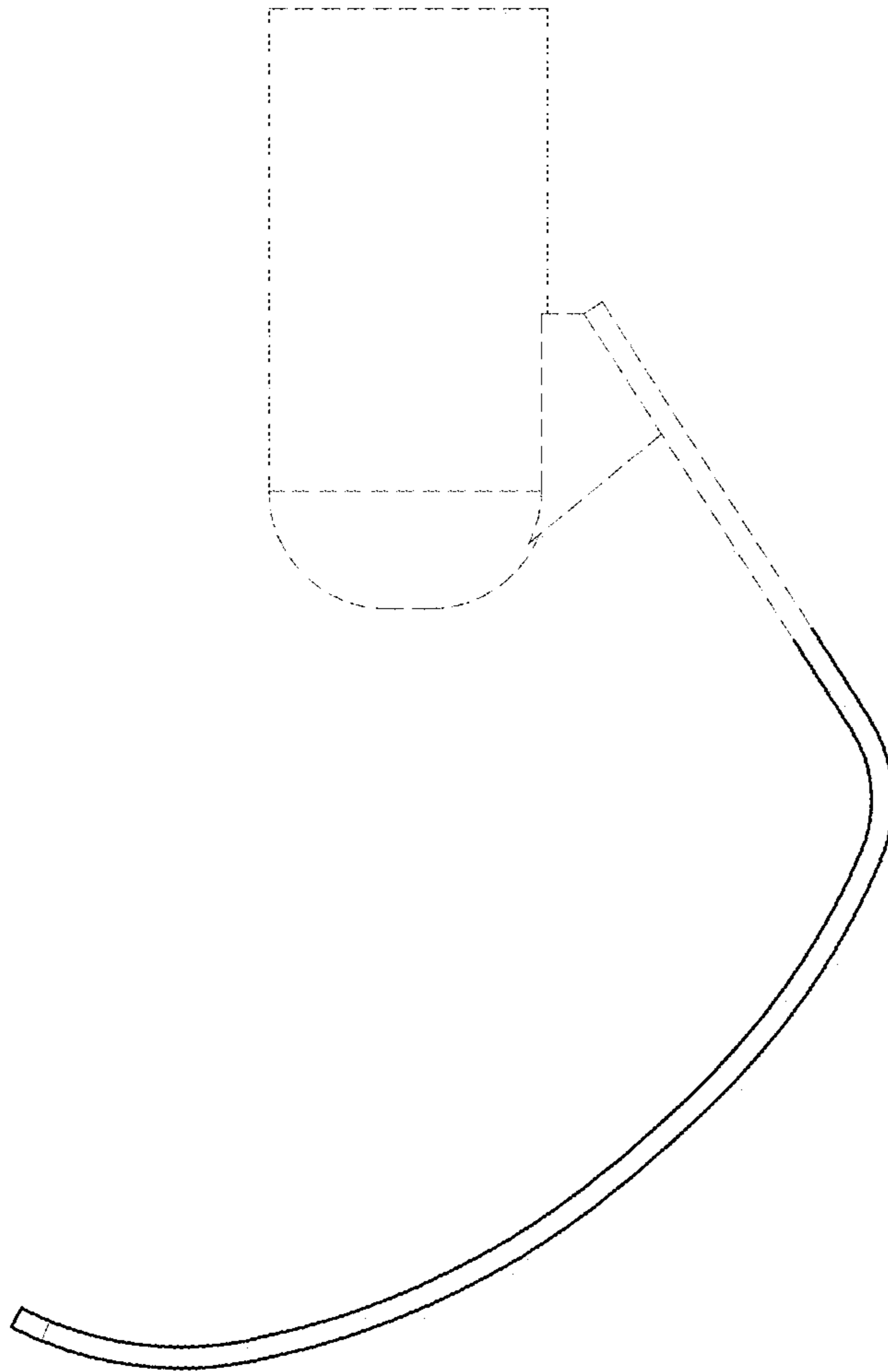

FIG. 25

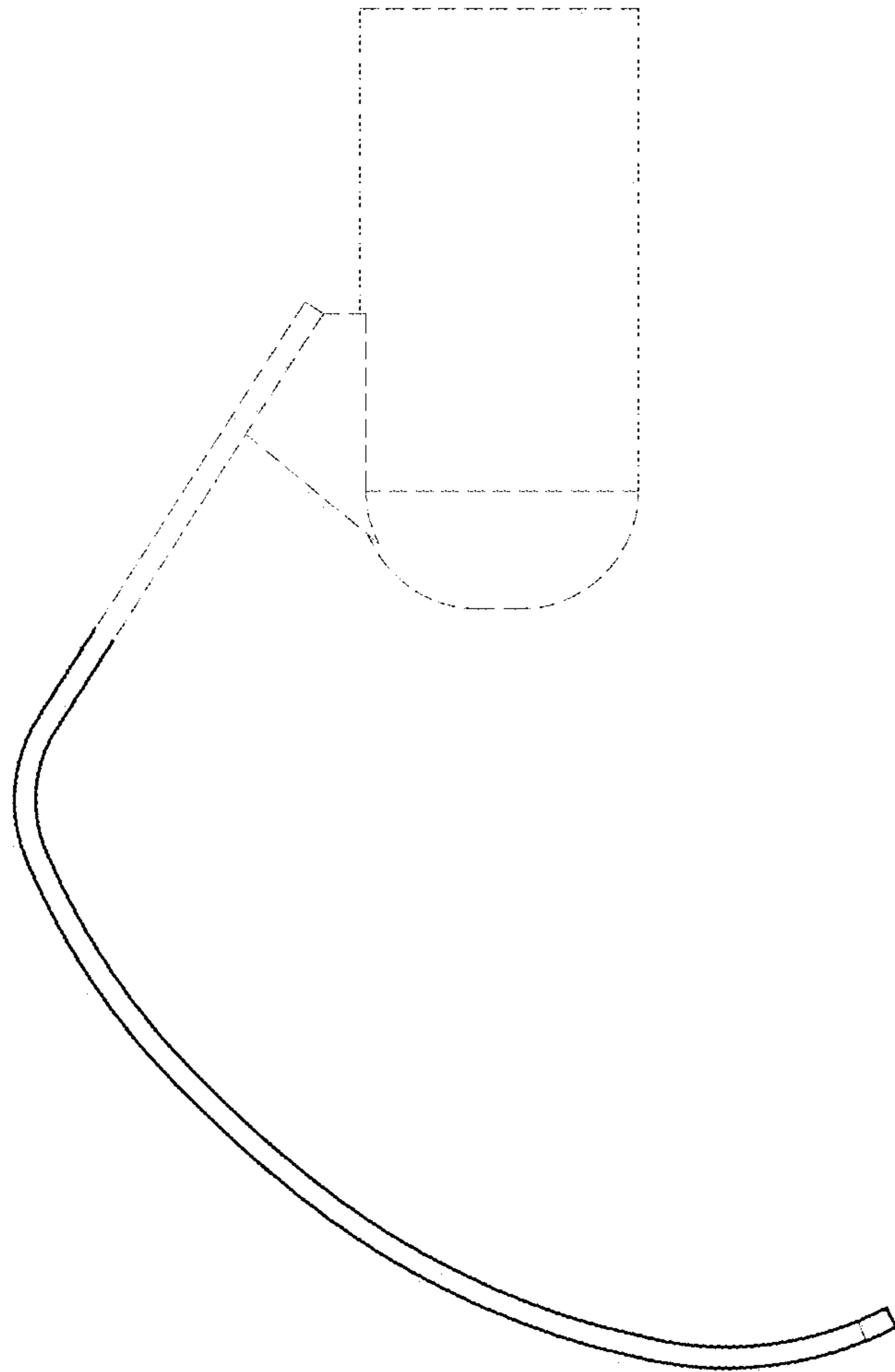

FIG. 26

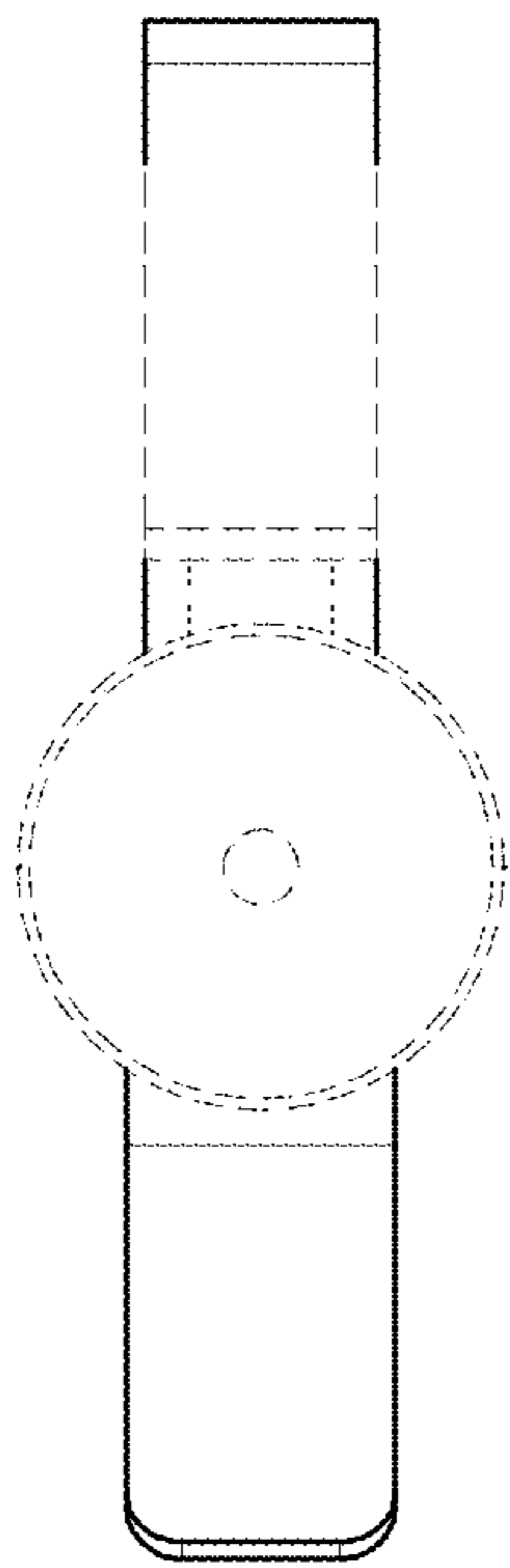

FIG. 27

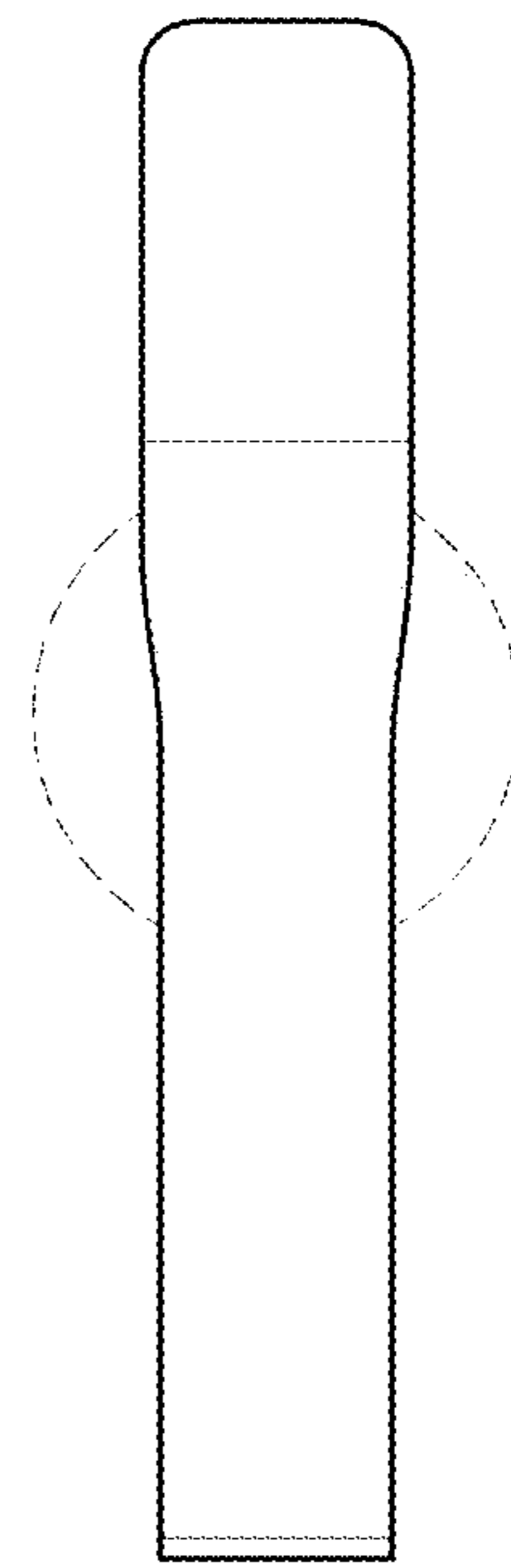

FIG. 28

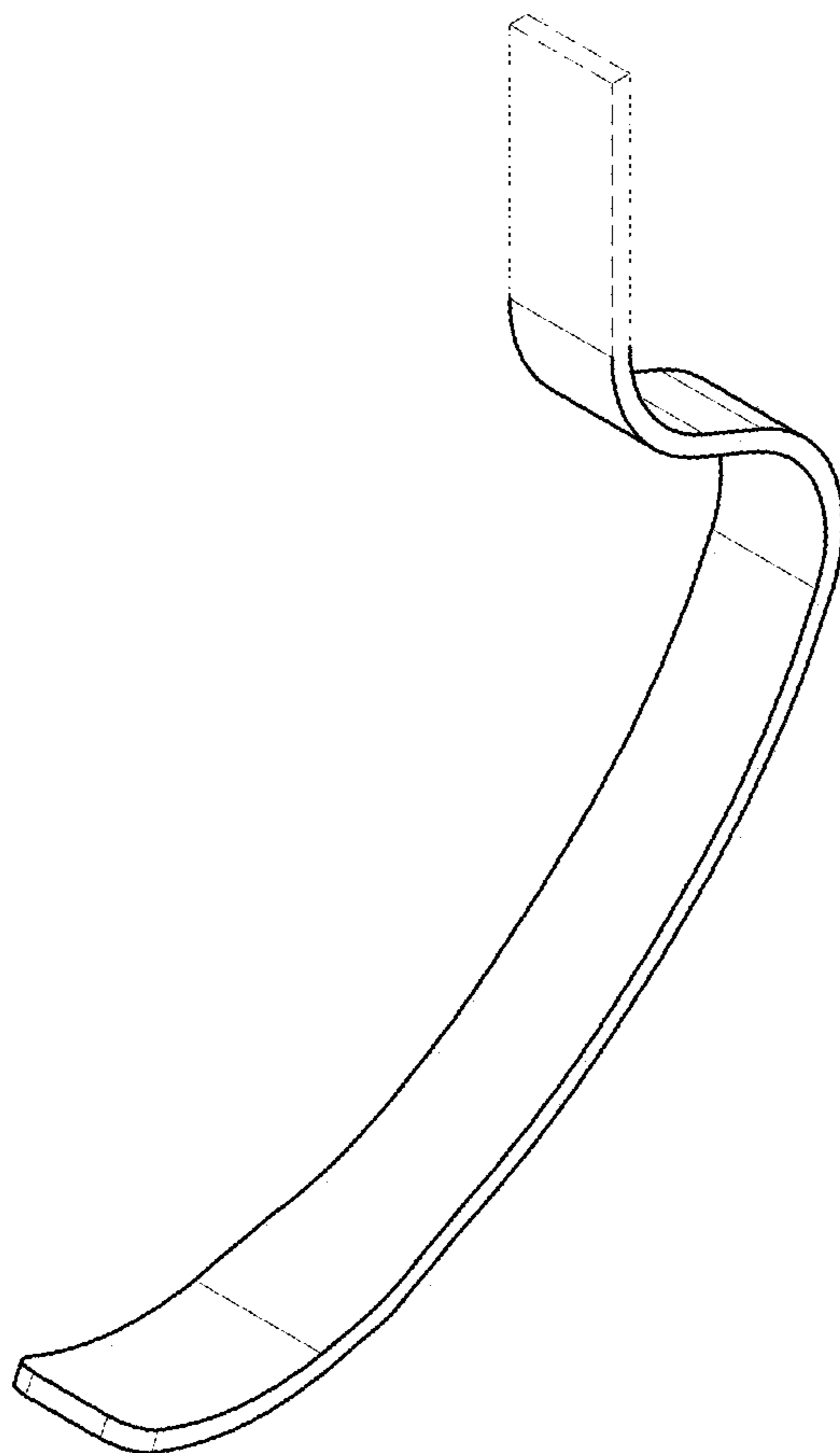

FIG. 29

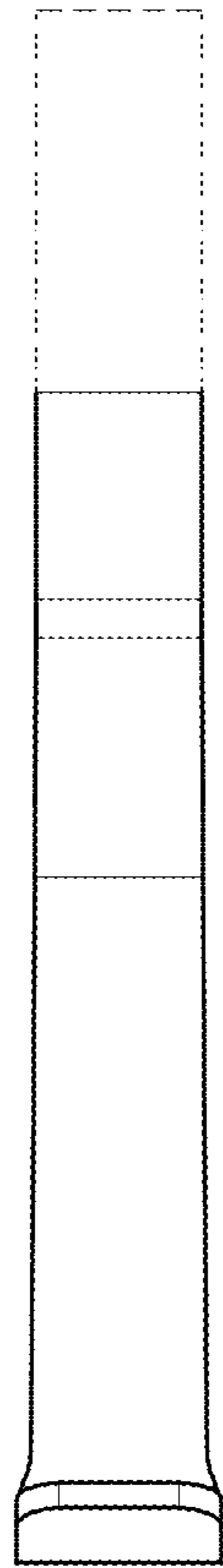

FIG. 30

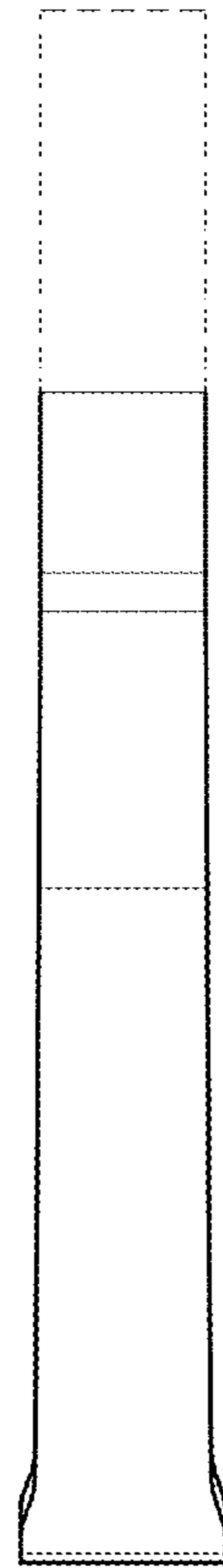

FIG. 31

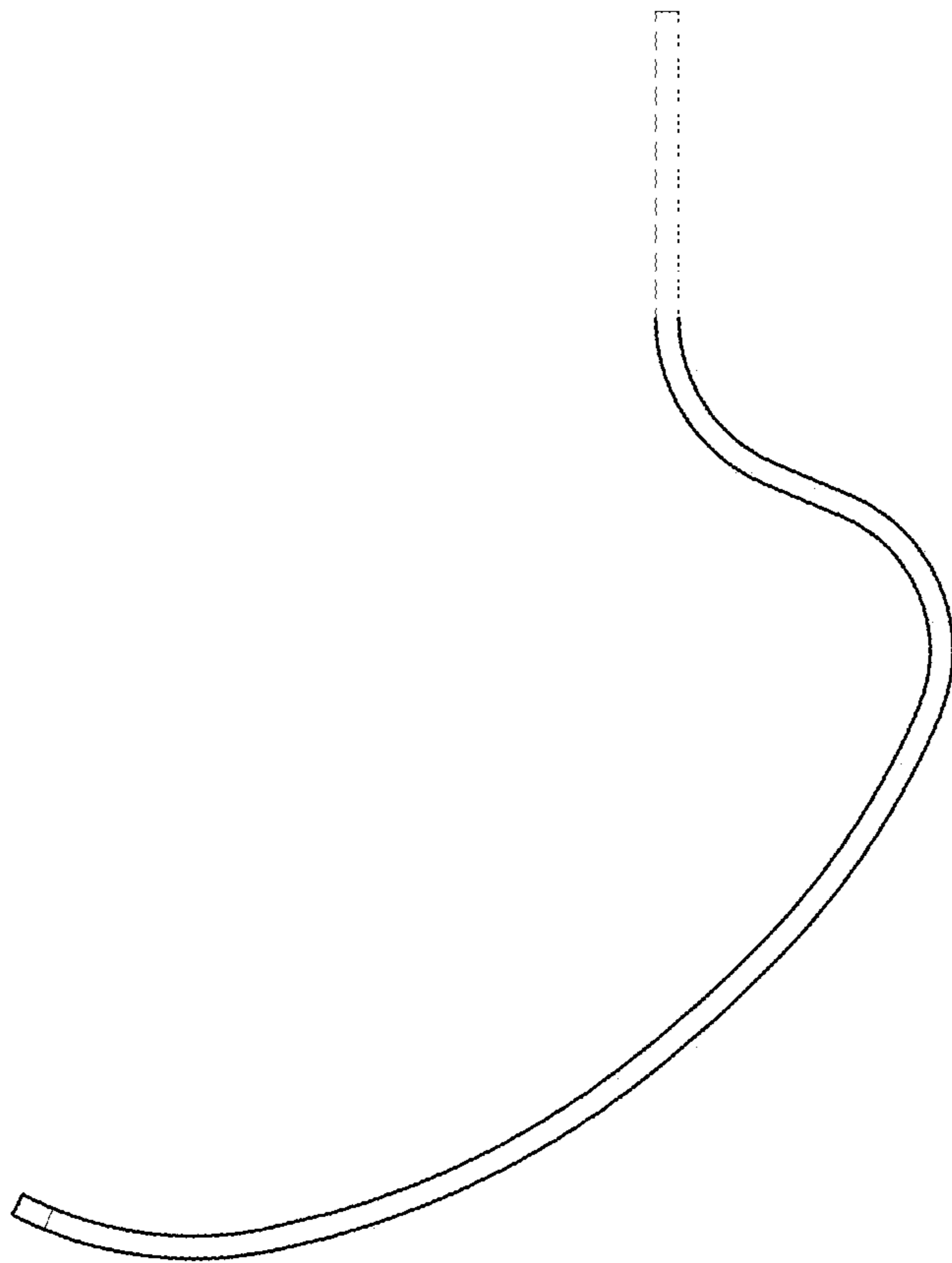

FIG. 32

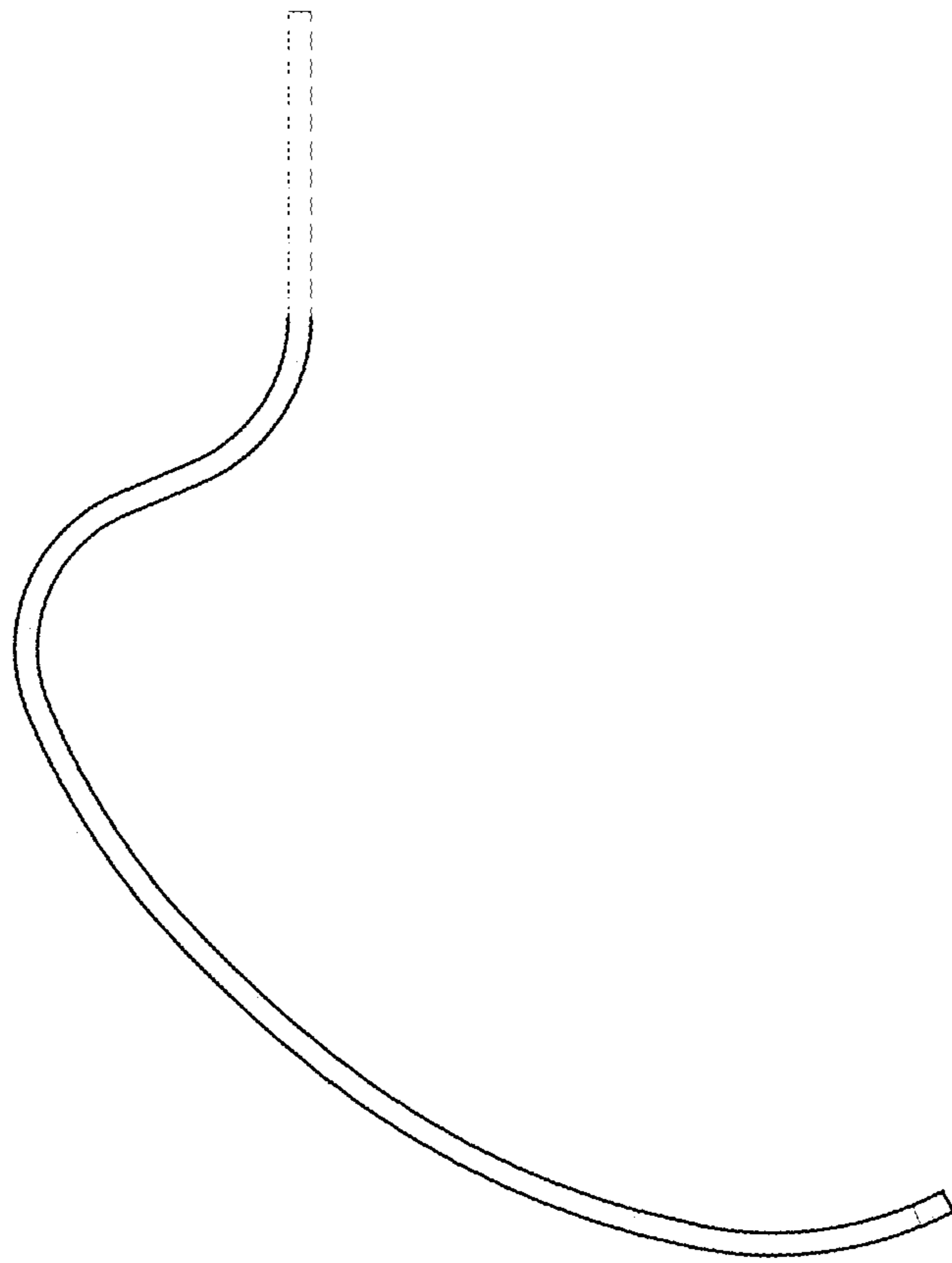

FIG. 33

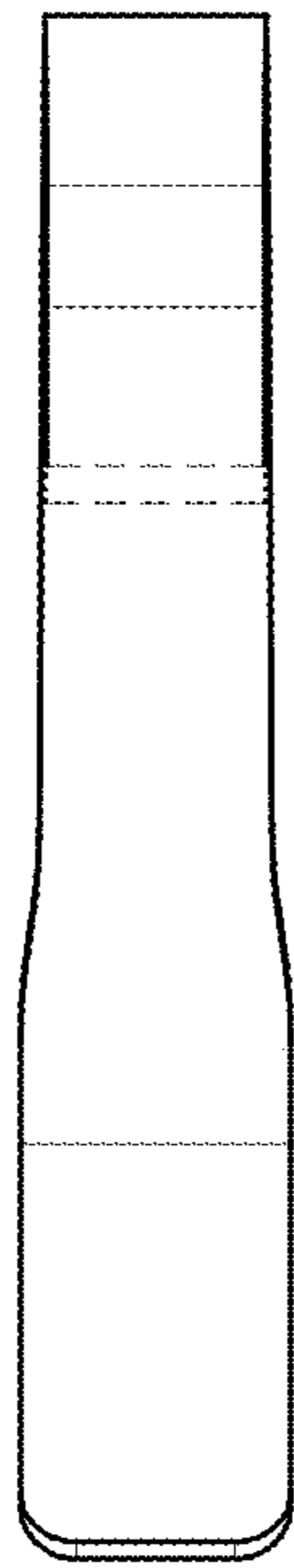

FIG. 34

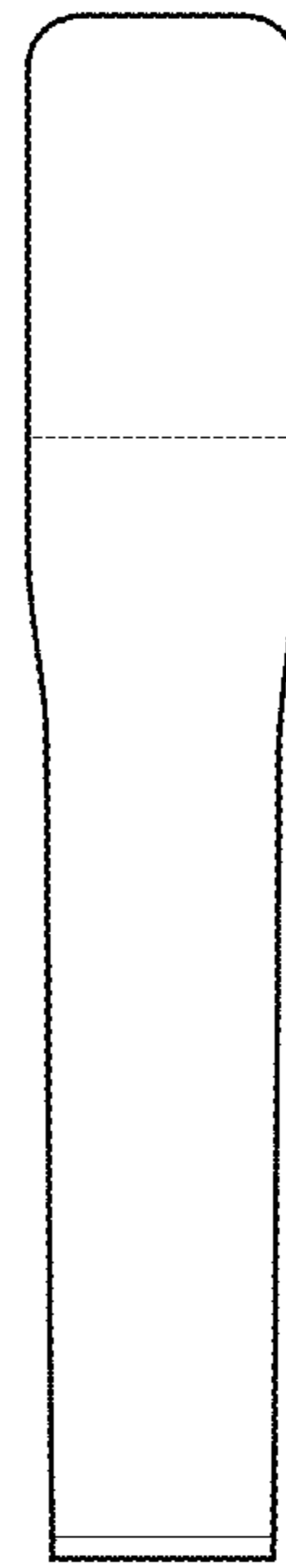

FIG. 35

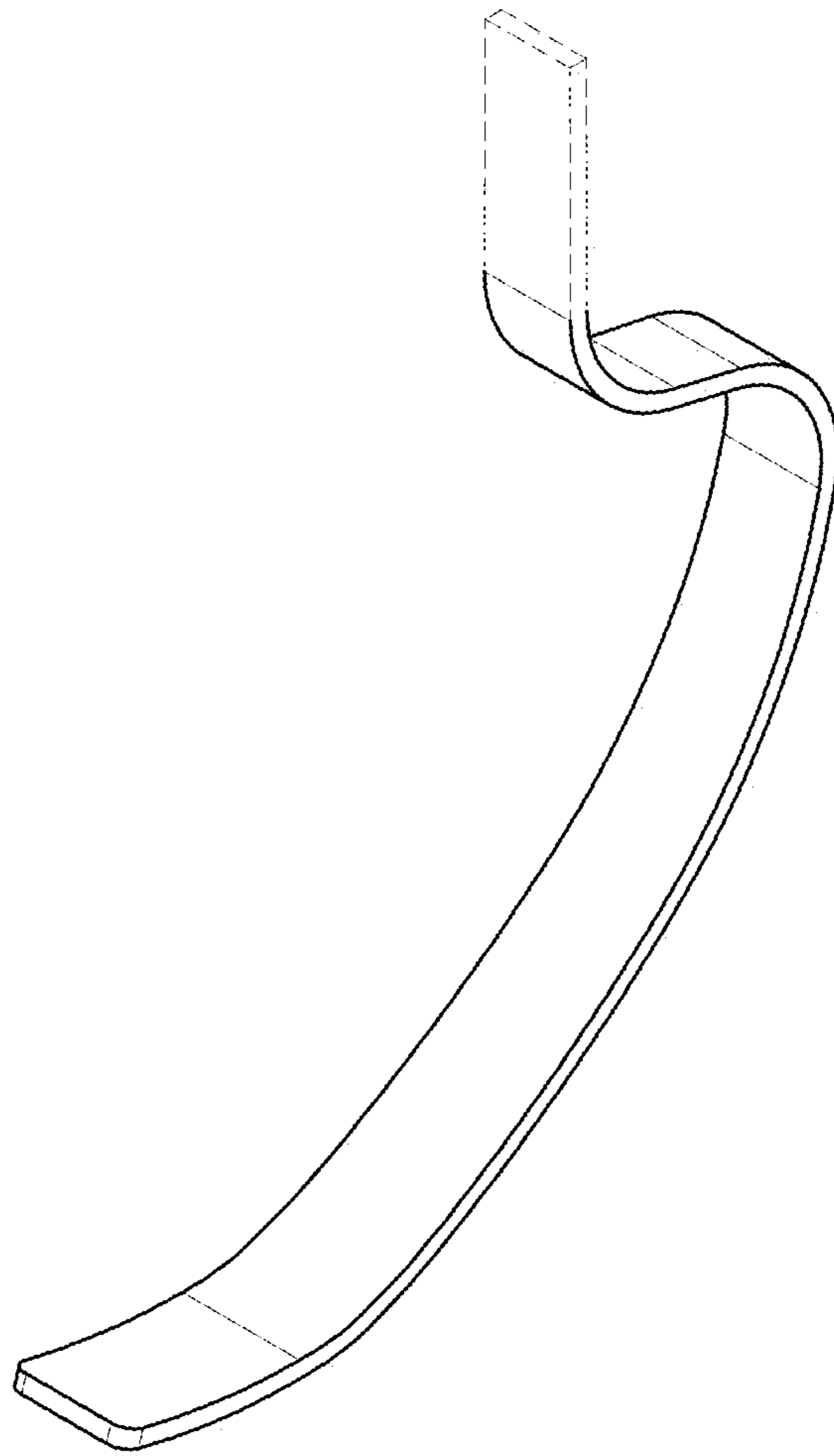

FIG. 36

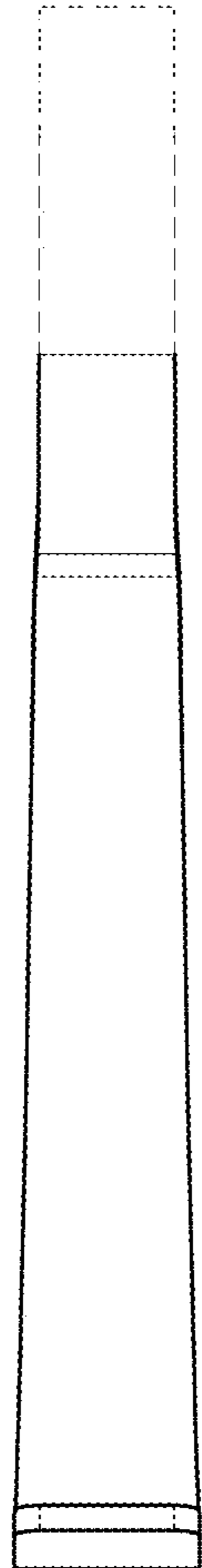

FIG. 37

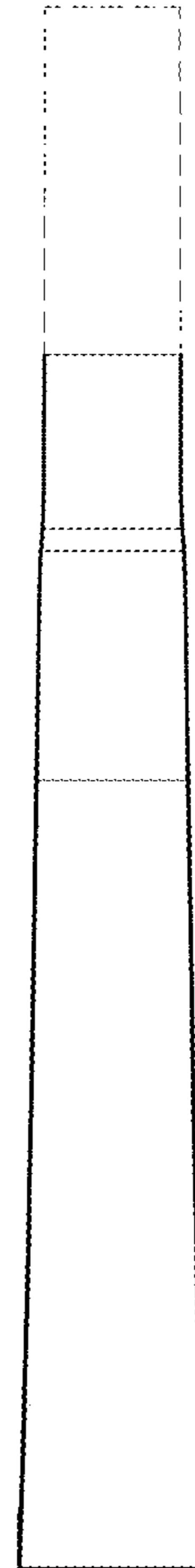

FIG. 38

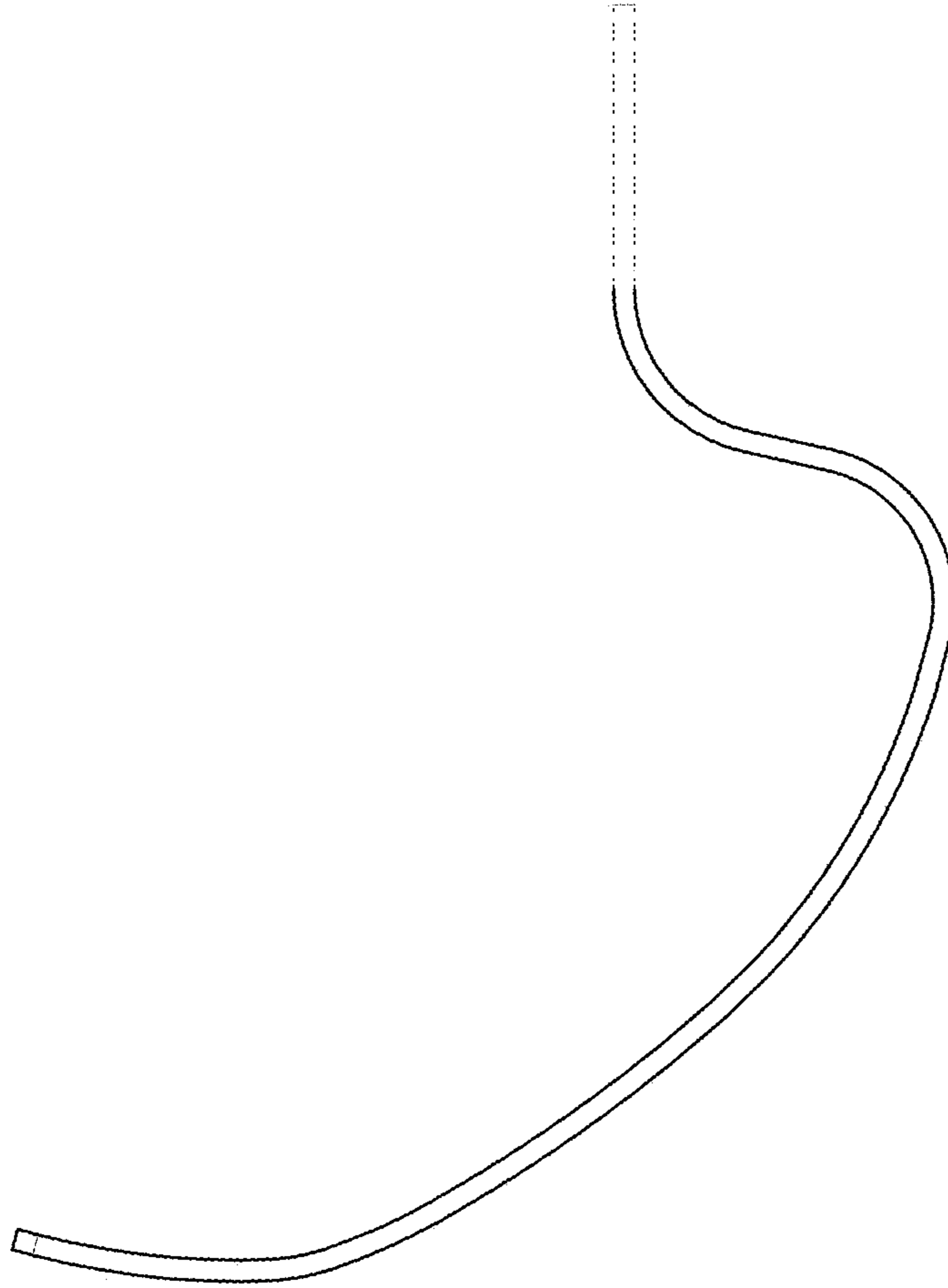

FIG. 39

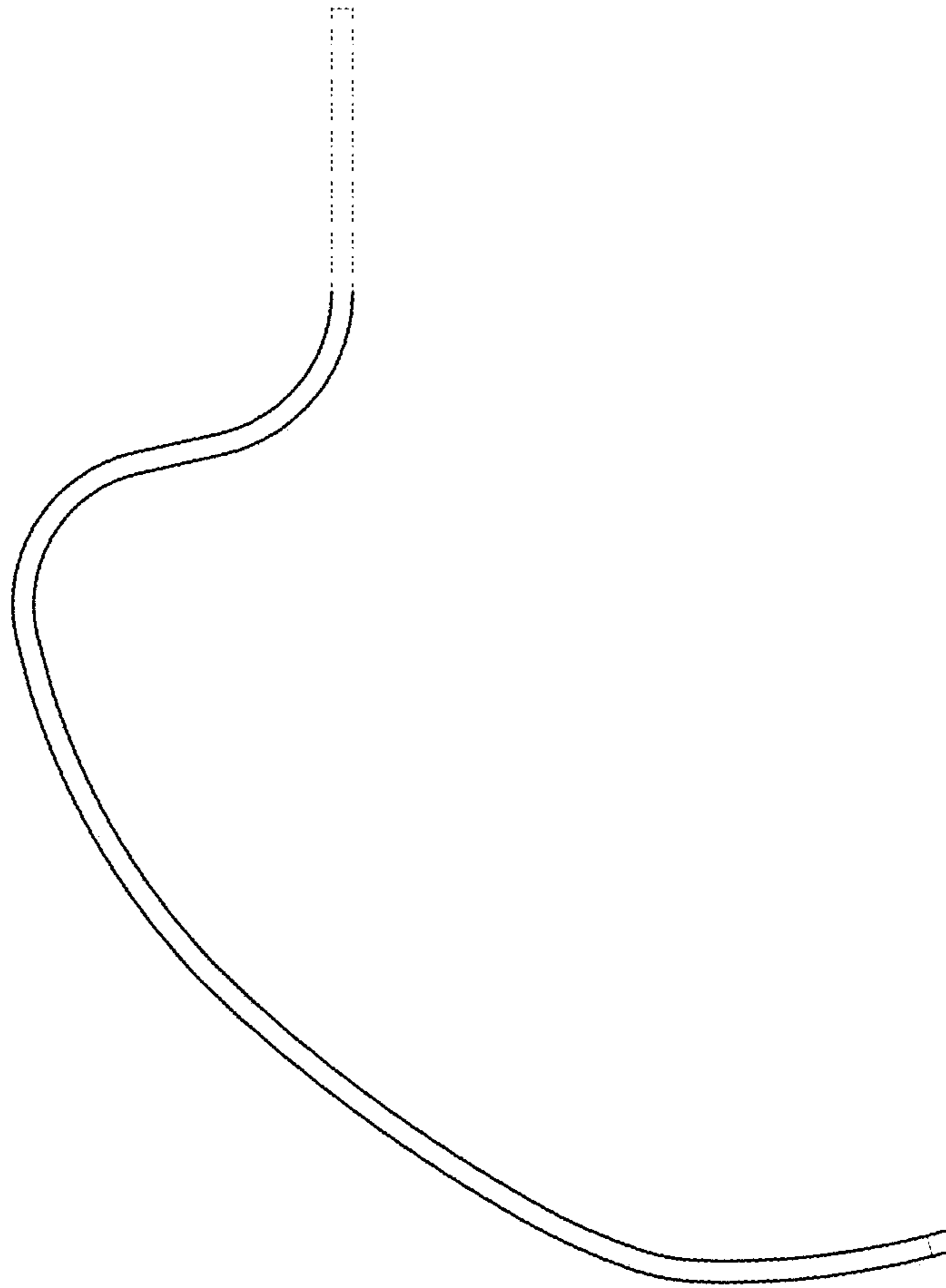

FIG. 40

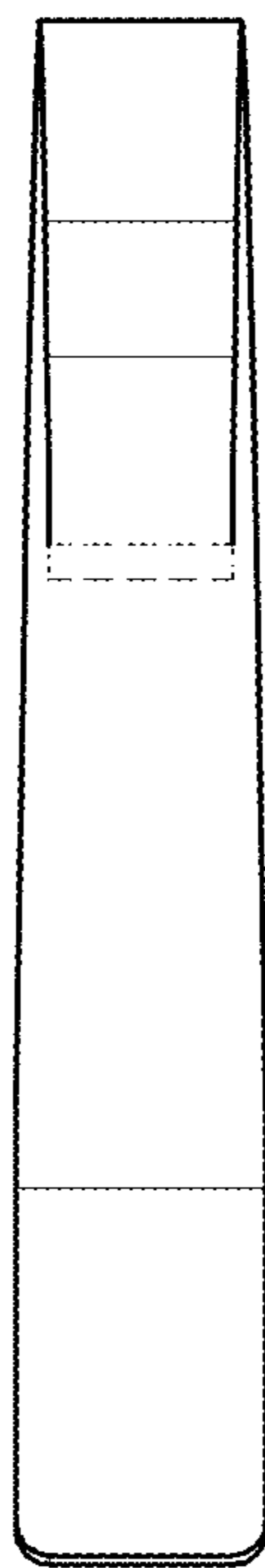

FIG. 41



FIG. 42

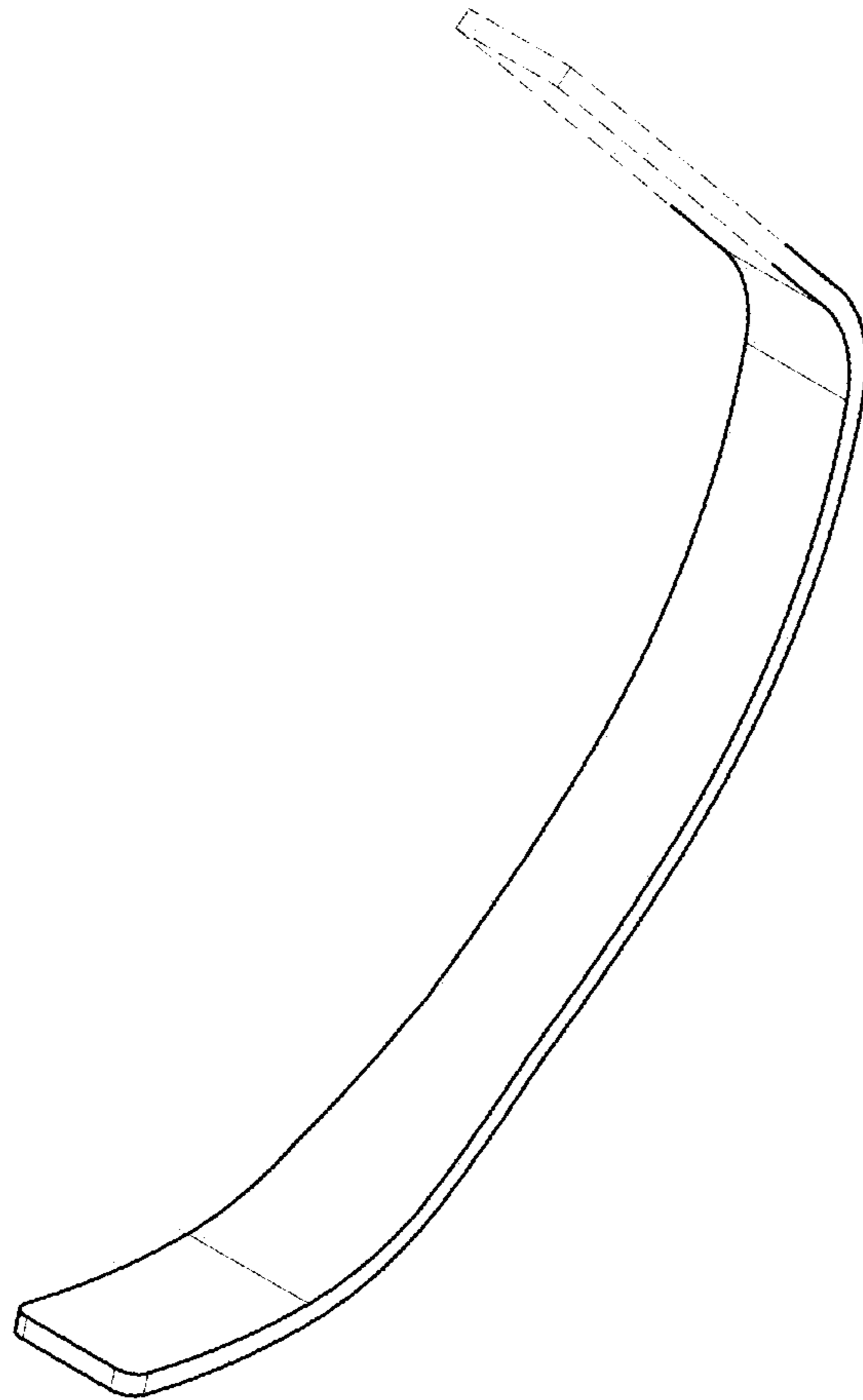

FIG. 43

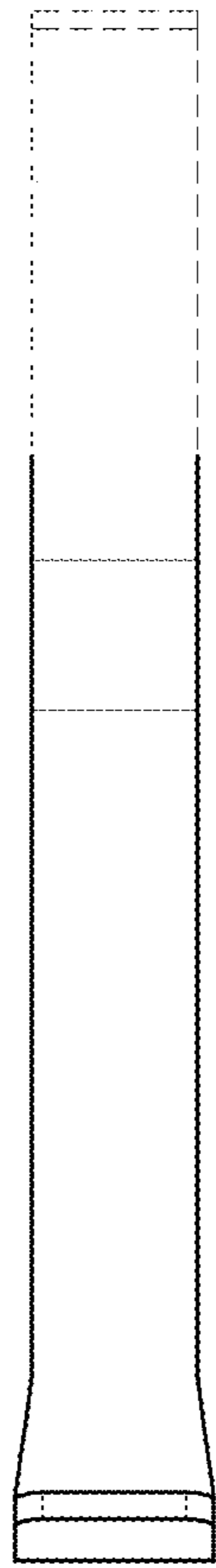

FIG. 44

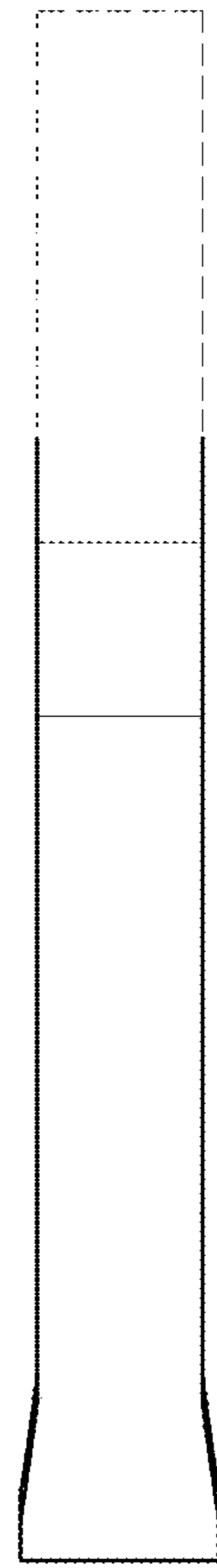

FIG. 45

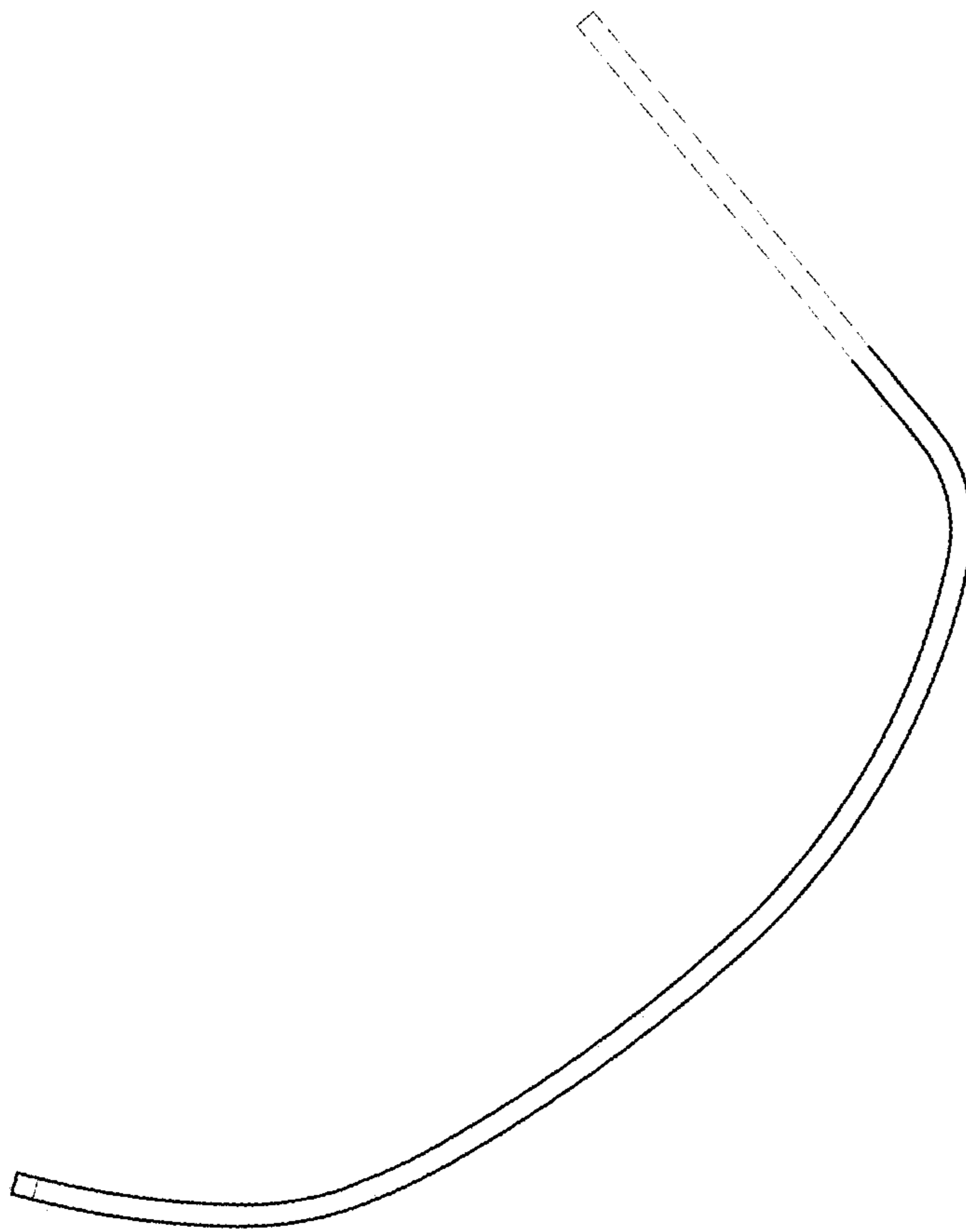

FIG. 46

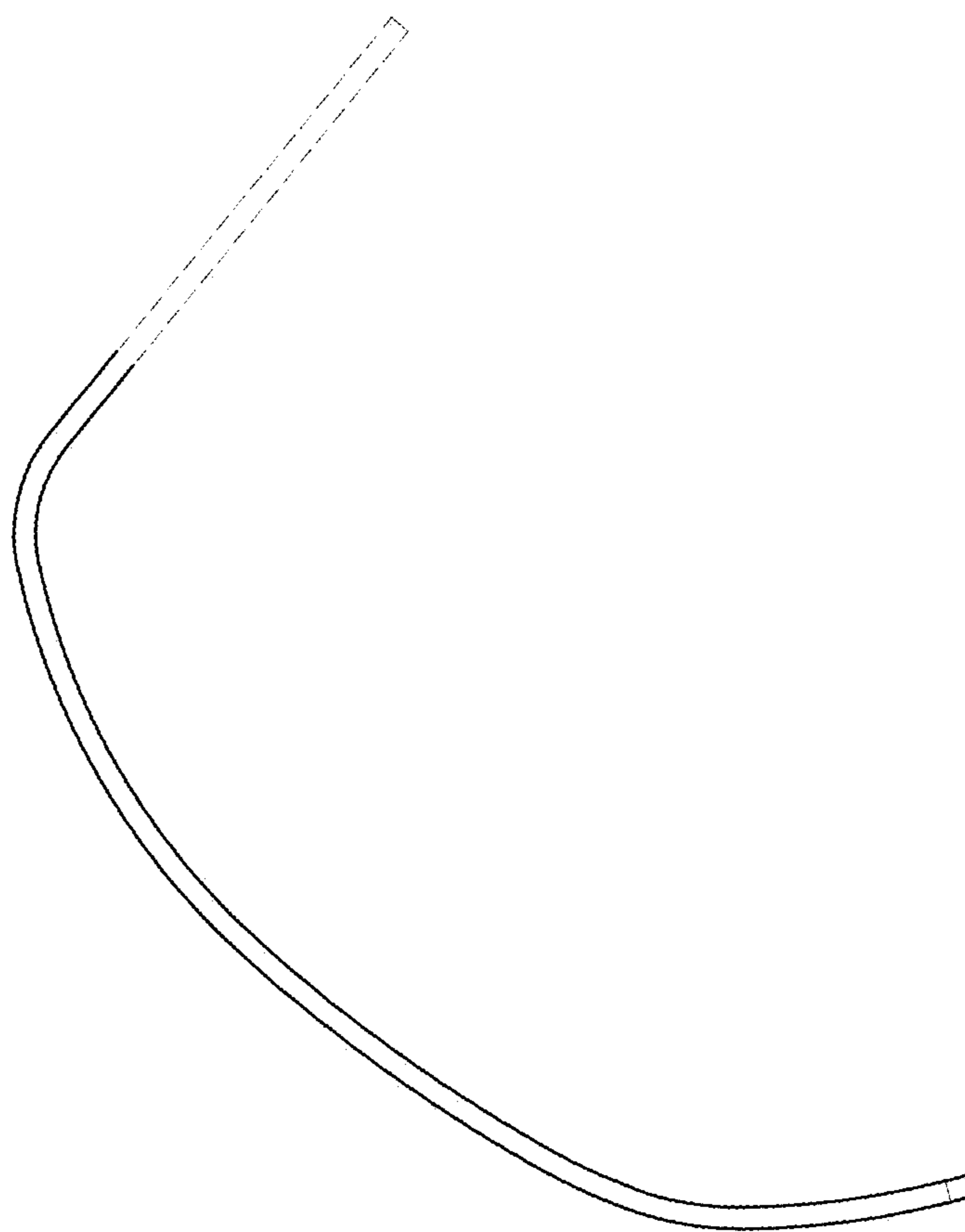

FIG. 47

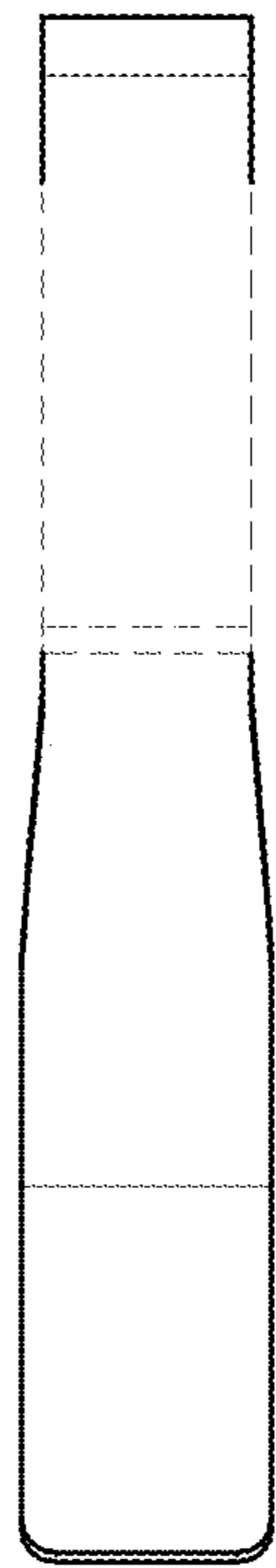

FIG. 48



FIG. 49

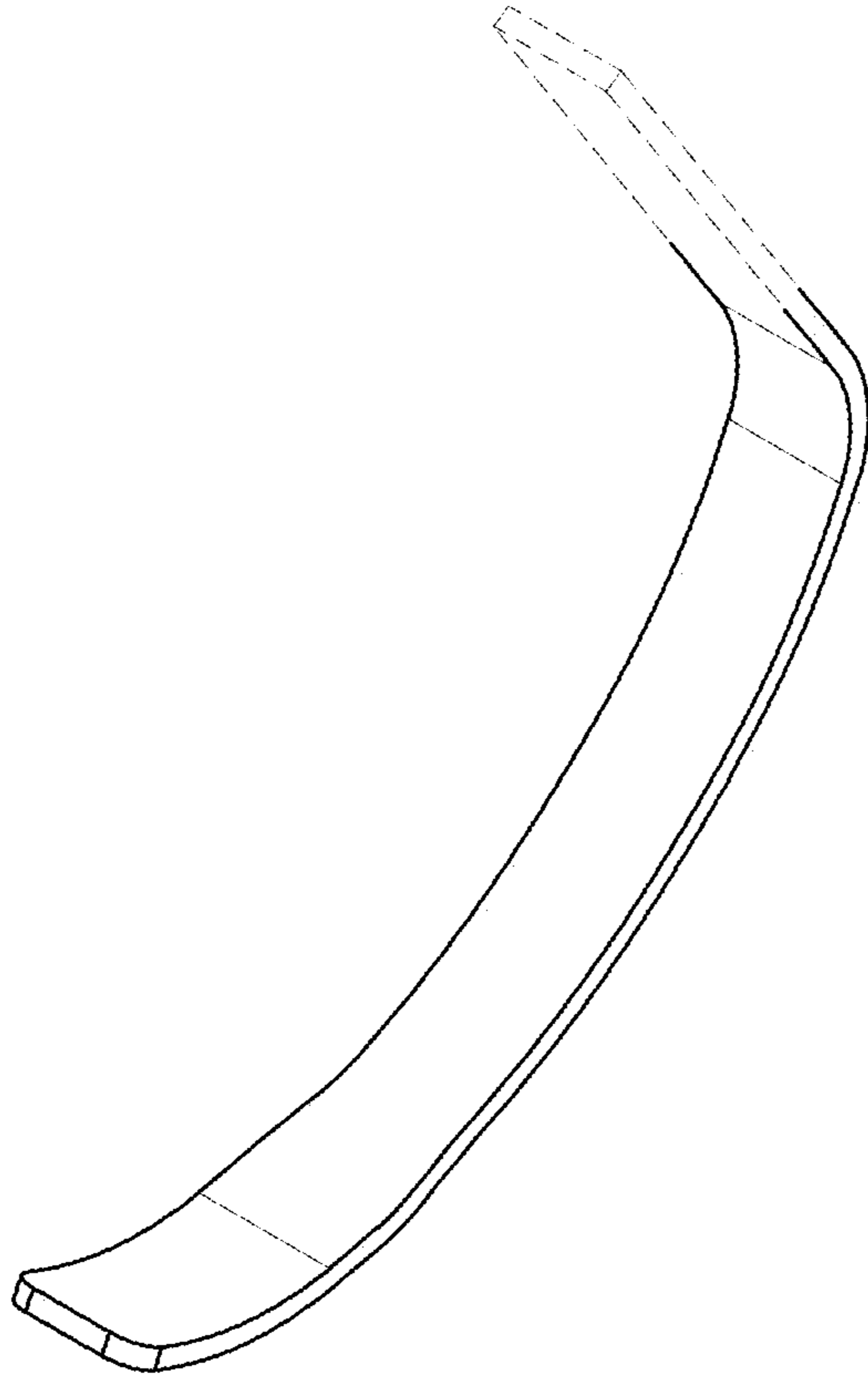

FIG. 50

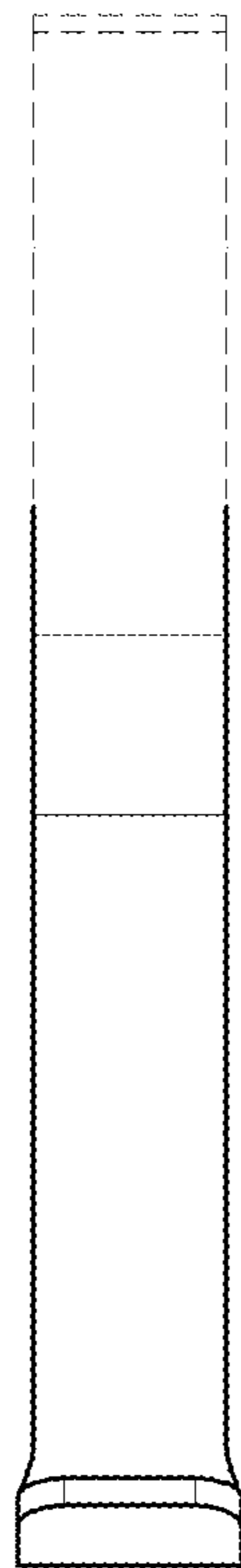

FIG. 51

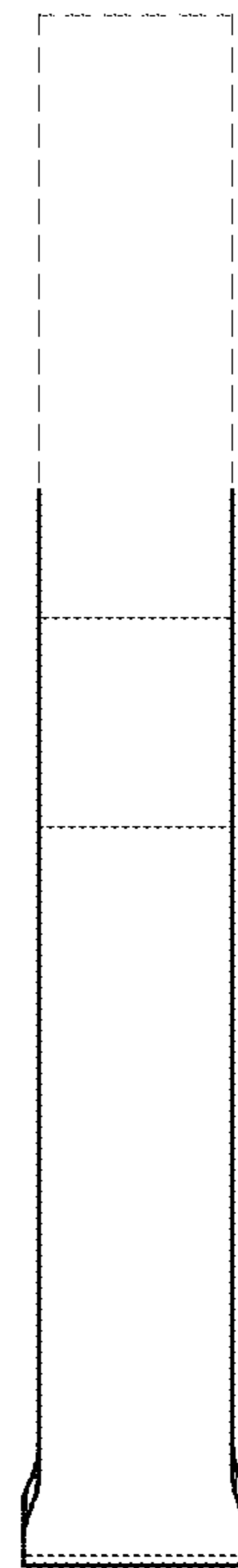

FIG. 52

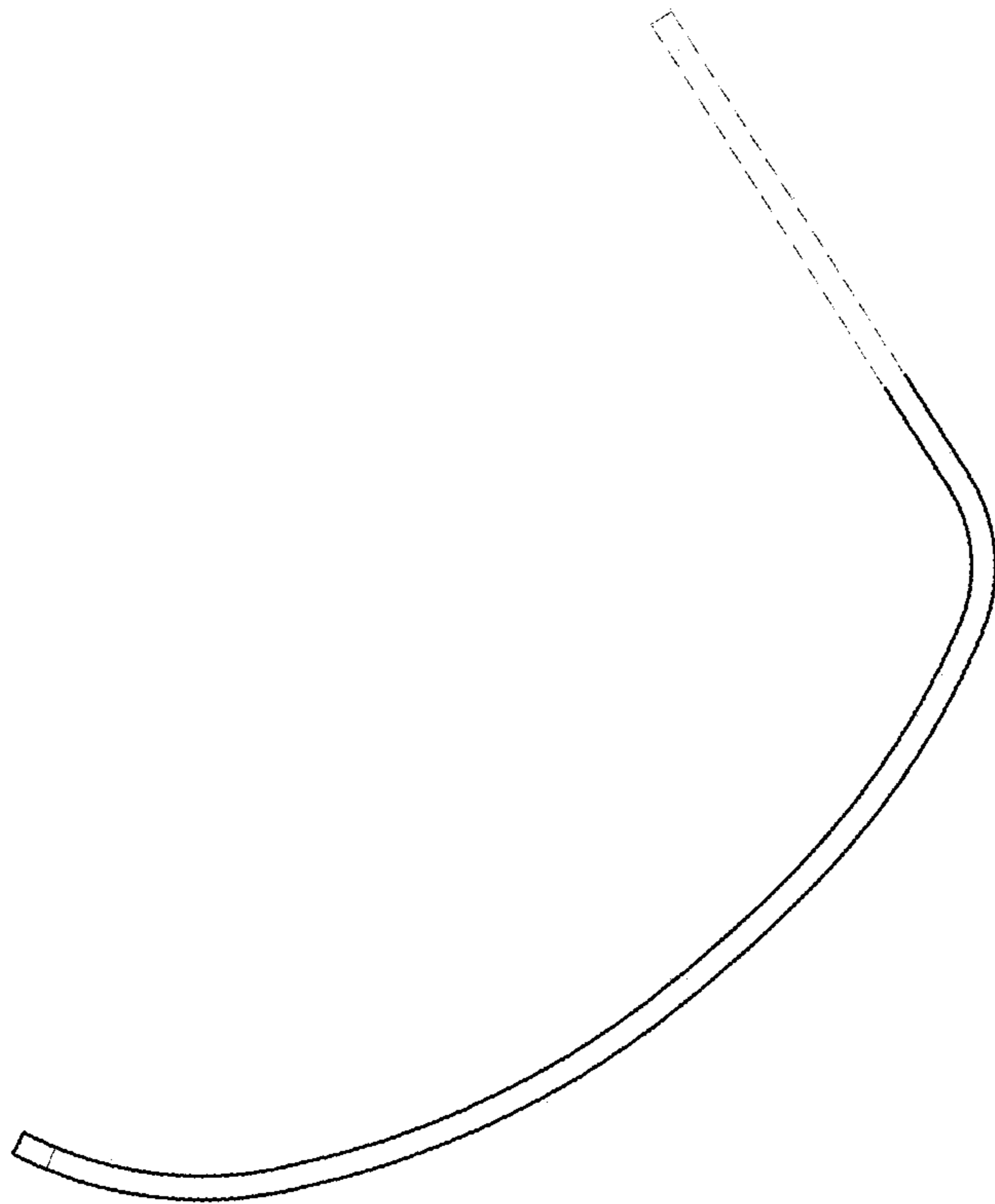

FIG. 53

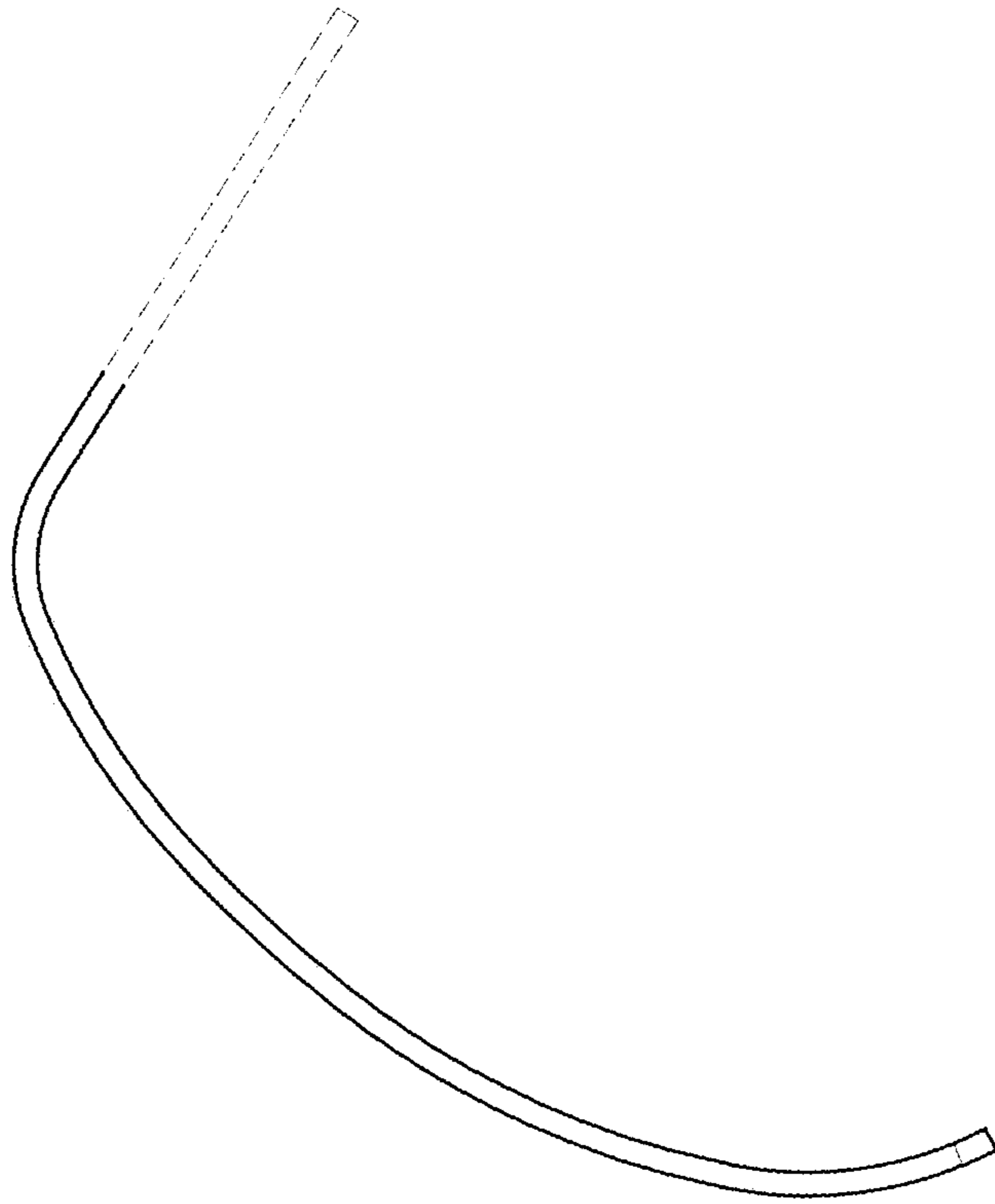

FIG. 54

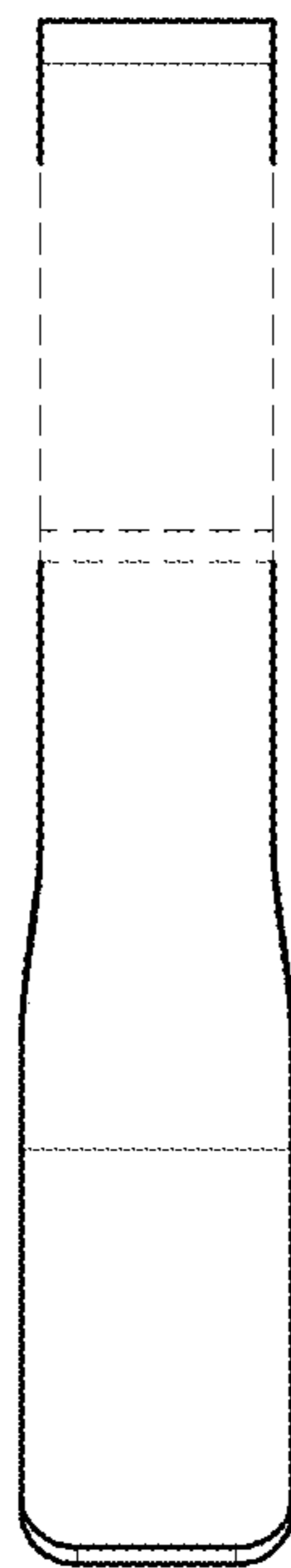

FIG. 55

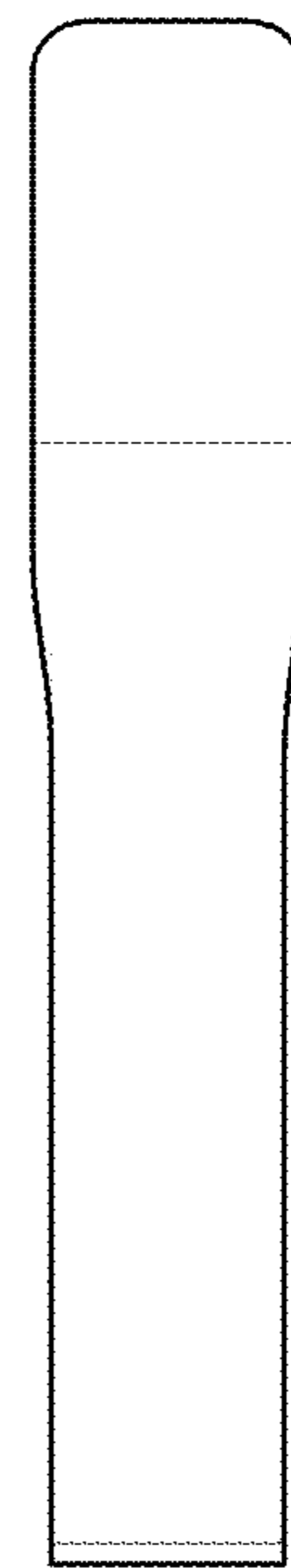

FIG. 56