



US00D904475S

(12) **United States Design Patent** (10) **Patent No.:** **US D904,475 S**
Preiss et al. (45) **Date of Patent:** **** Dec. 8, 2020**

(54) **TANDEM SUB**

(71) Applicant: **DynaEnergetics Europe GmbH**,
Troisdorf (DE)

(72) Inventors: **Frank Haron Preiss**, Bonn (DE); **Liam McNel**
is, Bonn (DE); **Eric Mulhern**,
Edmonton (CA); **Thilo Scharf**,
Letterkenny (IE); **David C. Parks**,
Calgary (CA)

(73) Assignee: **DynaEnergetics Europe GmbH**,
Troisdorf (DE)

(**) Term: **15 Years**

(21) Appl. No.: **29/733,080**

(22) Filed: **Apr. 29, 2020**

(51) **LOC (12) Cl.** **15-09**

(52) **U.S. Cl.**
USPC **D15/139**

(58) **Field of Classification Search**
USPC D8/354, 358, 382; D12/197; D15/21,
D15/126, 138, 139; D22/100, 112
(Continued)

(56) **References Cited**

U.S. PATENT DOCUMENTS

2,216,359 A 10/1940 Spencer
2,358,466 A 9/1944 Miller
(Continued)

FOREIGN PATENT DOCUMENTS

CA 2821506 A1 1/2015
CA 2824838 A1 2/2015
(Continued)

OTHER PUBLICATIONS

Dynaenergetics, Selection Perforating Switch, Product Information
Sheet, May 27, 2011, 1 pg.
(Continued)

Primary Examiner — Patricia A Palasik
(74) *Attorney, Agent, or Firm* — Moyles IP, LLC

(57) **CLAIM**

We claim the ornamental design of a tandem sub, as shown
and described.

DESCRIPTION

FIG. 1 is a front perspective view of a tandem sub showing
our new design;
FIG. 2 is a rear perspective view of the tandem sub of FIG.
1;
FIG. 3 is a top plan view of the tandem sub of FIG. 1;
FIG. 4 is a bottom plan view of the tandem sub of FIG. 1;
FIG. 5 is a left-side elevated view of the tandem sub of FIG.
1;
FIG. 6 is a right-side elevated view of the tandem sub of
FIG. 1;
FIG. 7 is a front elevated view of the tandem sub of FIG. 1;
FIG. 8 is a rear elevated view of the tandem sub of FIG. 1;
FIG. 9 is a front perspective view of a tandem sub of FIG.
1, showing an alternative disclaimed environment;
FIG. 10 is a top plan view of the tandem sub of FIG. 1,
showing the alternative disclaimed environment;
FIG. 11 is a bottom plan view of the tandem sub of FIG. 1,
showing the alternative disclaimed environment;
FIG. 12 is a left-side elevated view of the tandem sub of FIG.
1, showing the alternative disclaimed environment;
FIG. 13 is a right-side elevated view of the tandem sub of
FIG. 1, showing the alternative disclaimed environment;
FIG. 14 is a front elevated view of the tandem sub of FIG.
1, showing the alternative disclaimed environment; and,
FIG. 15 is a rear elevated view of the tandem sub of FIG. 1,
showing alternative disclaimed embodiment.
The broken lines consisting of dashes show an environment
that forms no part of the claimed design. The broken lines
consisting of a double-dot/dash pattern show a boundary of
the claimed design.

1 Claim, 13 Drawing Sheets

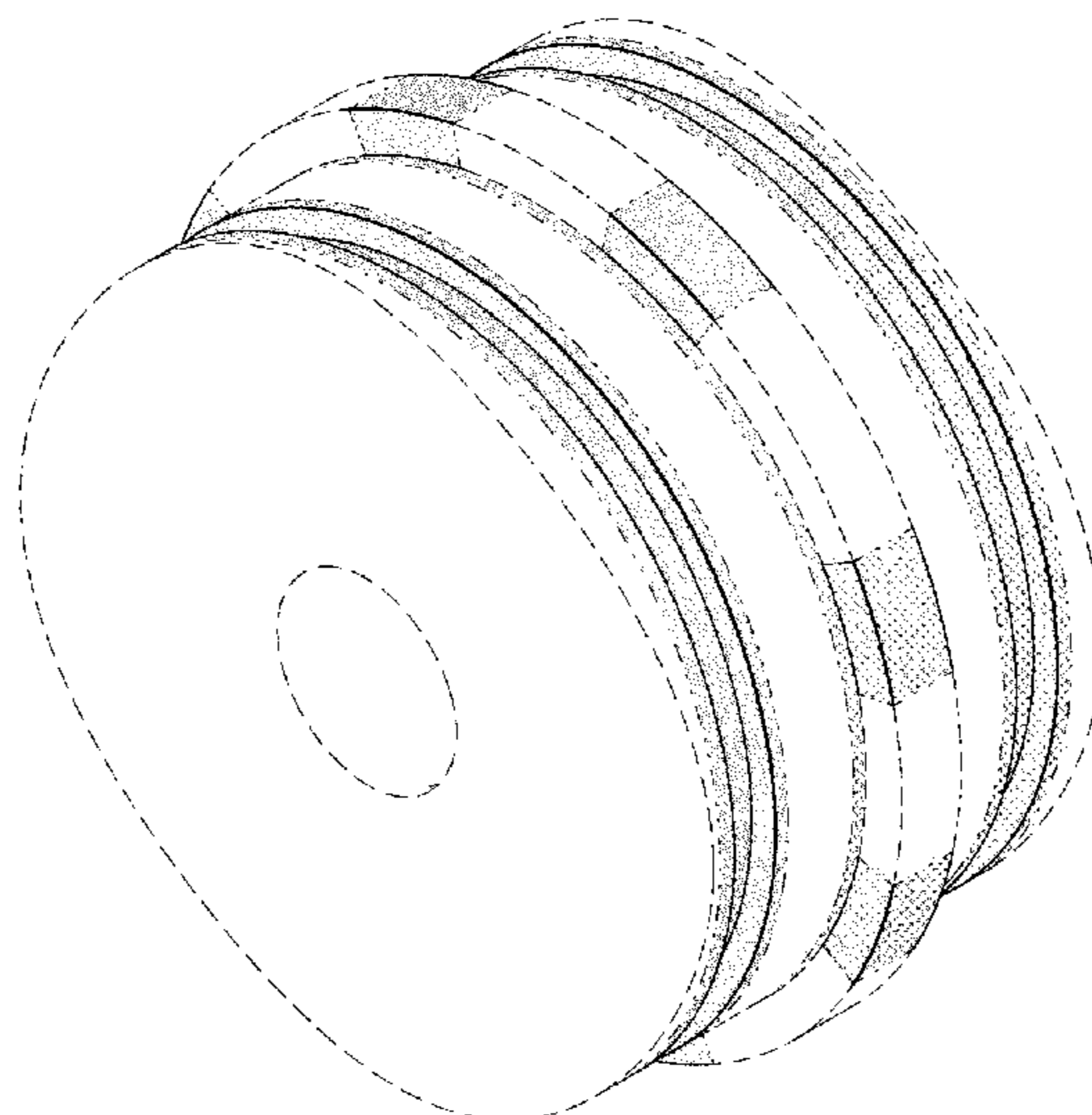

(58) **Field of Classification Search**
 CPC ... E21B 43/117; E21B 43/119; E21B 43/1185
 See application file for complete search history.

(56) **References Cited**

U.S. PATENT DOCUMENTS

2,418,486 A 4/1947 Smylie
 2,889,775 A 6/1959 Owen
 3,158,680 A 11/1964 Lovitt et al.
 3,170,400 A 2/1965 Nelson
 3,173,992 A 3/1965 Boop
 3,246,707 A 4/1966 Bell
 3,374,735 A 3/1968 Moore
 3,504,723 A 4/1970 Cushman et al.
 3,859,921 A 1/1975 Stephenson
 4,007,790 A 2/1977 Henning
 4,007,796 A 2/1977 Boop
 4,058,061 A 11/1977 Mansur, Jr. et al.
 4,100,978 A * 7/1978 Boop E21B 43/1185
 102/306
 4,140,188 A 2/1979 Vann
 4,182,216 A 1/1980 DeCaro
 4,266,613 A 5/1981 Boop
 4,290,486 A 9/1981 Regalbuto
 4,411,491 A 10/1983 Larkin et al.
 4,491,185 A 1/1985 McClure
 4,496,008 A 1/1985 Pottier et al.
 4,523,650 A 6/1985 Sehnert et al.
 4,574,892 A 3/1986 Grigar et al.
 4,598,775 A 7/1986 Vann et al.
 4,619,333 A 10/1986 George
 4,621,396 A 11/1986 Walker et al.
 4,650,009 A 3/1987 McClure et al.
 4,657,089 A 4/1987 Stout
 4,660,910 A 4/1987 Sharp et al.
 4,744,424 A 5/1988 Lendermon et al.
 4,747,201 A 5/1988 Donovan et al.
 4,753,170 A 6/1988 Regalbuto et al.
 4,776,393 A 10/1988 Forehand et al.
 4,790,383 A 12/1988 Savage et al.
 4,800,815 A 1/1989 Appledom et al.
 4,850,438 A 7/1989 Regalbuto
 4,889,183 A 12/1989 Sommers et al.
 5,027,708 A 7/1991 Gonzalez
 5,042,594 A * 8/1991 Gonzalez E21B 43/1185
 175/4.55
 5,052,489 A 10/1991 Carisella et al.
 5,060,573 A 10/1991 Montgomery et al.
 5,088,413 A 2/1992 Huber
 5,105,742 A 4/1992 Sumner
 5,159,145 A 10/1992 Carisella et al.
 5,159,146 A 10/1992 Carisella et al.
 5,223,665 A 6/1993 Burleson et al.
 5,237,136 A 8/1993 Langston
 5,241,891 A 9/1993 Hayes et al.
 5,322,019 A 6/1994 Hyland
 5,347,929 A 9/1994 Lerche et al.
 5,392,851 A * 2/1995 Arend E21B 17/023
 166/65.1
 5,392,860 A 2/1995 Ross
 5,436,791 A 7/1995 Turano et al.
 5,571,986 A 11/1996 Snider et al.
 5,603,384 A 2/1997 Bethel et al.
 5,703,319 A 12/1997 Fritz et al.
 5,775,426 A 7/1998 Snider et al.
 5,816,343 A 10/1998 Markel et al.
 5,871,052 A 2/1999 Benson et al.
 5,927,402 A 7/1999 Benson et al.
 D417,252 S * 11/1999 Kay D22/100
 5,992,289 A 11/1999 George et al.
 6,006,833 A 12/1999 Burleson et al.
 6,012,525 A 1/2000 Burleson et al.
 6,085,659 A 7/2000 Beukes et al.
 6,112,666 A 9/2000 Murray et al.
 6,263,283 B1 * 7/2001 Snider G01V 1/104
 702/6

6,298,915 B1 10/2001 George
 6,305,287 B1 10/2001 Capers et al.
 6,333,699 B1 12/2001 Zierolf
 6,354,374 B1 3/2002 Edwards et al.
 6,412,388 B1 7/2002 Frazier
 6,418,853 B1 7/2002 Duguet et al.
 6,439,121 B1 8/2002 Gillingham
 6,497,285 B2 12/2002 Walker
 6,516,901 B1 2/2003 Falgout
 6,651,747 B2 11/2003 Chen et al.
 6,719,061 B2 4/2004 Muller et al.
 6,739,265 B1 5/2004 Badger et al.
 6,742,602 B2 6/2004 Trotechaud
 6,752,083 B1 6/2004 Lerche et al.
 6,843,317 B2 1/2005 Mackenzie
 7,013,977 B2 3/2006 Nordaas
 7,107,908 B2 9/2006 Forman et al.
 7,193,527 B2 3/2007 Hall
 7,278,491 B2 10/2007 Scott
 7,347,278 B2 3/2008 Lerche et al.
 7,533,722 B2 5/2009 George et al.
 7,568,429 B2 8/2009 Hummel et al.
 7,591,212 B2 9/2009 Myers, Jr. et al.
 7,661,474 B2 2/2010 Campbell et al.
 7,762,172 B2 7/2010 Li et al.
 7,762,351 B2 7/2010 Vidal
 7,778,006 B2 8/2010 Stewart et al.
 7,810,430 B2 10/2010 Chan et al.
 7,908,970 B1 3/2011 Jakaboski et al.
 7,929,270 B2 4/2011 Hummel et al.
 8,066,083 B2 11/2011 Hales et al.
 8,069,789 B2 12/2011 Hummel et al.
 8,074,737 B2 12/2011 Hill et al.
 8,079,296 B2 12/2011 Barton et al.
 8,127,846 B2 3/2012 Hill et al.
 8,136,439 B2 * 3/2012 Bell E21B 29/02
 166/55
 8,157,022 B2 4/2012 Bertoja et al.
 8,181,718 B2 5/2012 Burleson et al.
 8,182,212 B2 5/2012 Parcell
 8,186,259 B2 5/2012 Burleson et al.
 8,230,932 B2 7/2012 Ratcliffe et al.
 8,256,337 B2 9/2012 Hill
 8,336,437 B2 12/2012 Barlow et al.
 8,395,878 B2 3/2013 Stewart et al.
 8,451,137 B2 5/2013 Bonavides et al.
 8,469,087 B2 6/2013 Gray
 8,661,978 B2 3/2014 Backhus et al.
 8,695,506 B2 4/2014 Lanclos
 8,770,301 B2 * 7/2014 Bell E21B 43/1185
 166/297
 8,863,665 B2 10/2014 DeVries et al.
 8,869,887 B2 10/2014 Deere et al.
 8,875,787 B2 * 11/2014 Tassaroli E21B 43/1185
 166/297
 8,881,816 B2 11/2014 Glenn et al.
 8,910,718 B2 12/2014 Watson et al.
 8,985,023 B2 3/2015 Mason
 9,080,433 B2 7/2015 Lanclos et al.
 9,145,763 B1 9/2015 Sites, Jr.
 9,145,764 B2 * 9/2015 Burton F42D 1/043
 9,157,718 B2 10/2015 Ross
 9,175,553 B2 11/2015 Mccann et al.
 9,181,790 B2 11/2015 Mace et al.
 9,194,219 B1 11/2015 Hardesty et al.
 9,206,675 B2 12/2015 Hales et al.
 9,284,819 B2 3/2016 Tolman et al.
 9,441,465 B2 * 9/2016 Tassaroli E21B 43/116
 9,476,289 B2 10/2016 Wells
 9,494,021 B2 11/2016 Parks et al.
 9,518,443 B2 12/2016 Tunget et al.
 9,518,454 B2 12/2016 Current et al.
 9,574,416 B2 2/2017 Wright et al.
 9,581,422 B2 2/2017 Preiss et al.
 9,598,942 B2 3/2017 Wells et al.
 9,605,937 B2 3/2017 Eitschberger et al.
 9,677,363 B2 6/2017 Schacherer et al.
 9,689,223 B2 6/2017 Schacherer et al.
 9,689,240 B2 6/2017 LaGrange et al.

(56)

References Cited

U.S. PATENT DOCUMENTS

9,702,680 B2 7/2017 Parks et al.
 9,784,549 B2 10/2017 Eitschberger
 9,810,035 B1 11/2017 Carr et al.
 9,822,618 B2* 11/2017 Eitschberger F42B 3/26
 9,835,015 B2 12/2017 Hardesty
 9,874,083 B2 1/2018 Logan et al.
 9,903,192 B2 2/2018 Entchev et al.
 10,066,921 B2 9/2018 Eitschberger
 10,077,641 B2 9/2018 Rogman et al.
 10,138,713 B2 11/2018 Tolman et al.
 10,151,152 B2 12/2018 Wight et al.
 10,151,180 B2 12/2018 Robey et al.
 10,151,181 B2 12/2018 Lopez et al.
 10,174,595 B2 1/2019 Knight et al.
 10,188,990 B2 1/2019 Burmeister et al.
 10,190,398 B2 1/2019 Goodman et al.
 10,273,788 B2* 4/2019 Bradley F42B 3/08
 10,337,270 B2 7/2019 Carisella et al.
 10,352,136 B2 7/2019 Goyeneche
 10,352,144 B2 7/2019 Entchev et al.
 10,422,195 B2 9/2019 LaGrange et al.
 10,429,161 B2 10/2019 Parks et al.
 10,458,213 B1* 10/2019 Eitschberger E21B 43/1185
 10,472,938 B2* 11/2019 Parks E21B 43/1185
 D873,373 S* 1/2020 Hartman D22/112
 2002/0020320 A1 2/2002 Lebaudy et al.
 2002/0062991 A1 5/2002 Farrant et al.
 2003/0000411 A1 1/2003 Cernocky et al.
 2003/0001753 A1 1/2003 Cernocky et al.
 2004/0216632 A1 11/2004 Finsterwald
 2004/0239521 A1 12/2004 Zierolf
 2005/0178282 A1 8/2005 Brooks et al.
 2005/0194146 A1 9/2005 Barker et al.
 2005/0229805 A1 10/2005 Myers, Jr. et al.
 2007/0084336 A1 4/2007 Neves
 2007/0125540 A1 6/2007 Gerez et al.
 2007/0158071 A1 7/2007 Mooney et al.
 2007/0267195 A1 11/2007 Grigar et al.
 2008/0047456 A1 2/2008 Li et al.
 2008/0110612 A1 5/2008 Prinz et al.
 2008/0110632 A1* 5/2008 Beall E21B 34/103
 166/332.3
 2008/0134922 A1 6/2008 Grattan et al.
 2008/0149338 A1 6/2008 Goodman et al.
 2008/0173204 A1 7/2008 Anderson et al.
 2008/0264639 A1 10/2008 Parrott et al.
 2009/0050322 A1 2/2009 Hill et al.
 2009/0272529 A1 11/2009 Crawford
 2009/0301723 A1 12/2009 Gray
 2010/0000789 A1 1/2010 Barton et al.
 2010/0024674 A1 2/2010 Peeters et al.
 2010/0089643 A1 4/2010 Vidal
 2010/0096131 A1 4/2010 Hill et al.
 2010/0163224 A1 7/2010 Strickland
 2010/0230104 A1 9/2010 Noelke et al.
 2011/0024116 A1 2/2011 McCann et al.
 2012/0006217 A1* 1/2012 Anderson E21B 43/1185
 102/215
 2012/0085538 A1 4/2012 Guerrero et al.
 2012/0152542 A1 6/2012 Le
 2012/0160483 A1* 6/2012 Carisella E21B 27/02
 166/270
 2012/0199031 A1 8/2012 Lanclos
 2012/0199352 A1 8/2012 Lanclos et al.
 2012/0241169 A1 9/2012 Hales et al.
 2012/0242135 A1 9/2012 Thomson et al.
 2012/0247769 A1 10/2012 Schacherer et al.
 2012/0247771 A1 10/2012 Black et al.
 2012/0298361 A1 11/2012 Sampson
 2013/0008639 A1 1/2013 Tassaroli
 2013/0043074 A1* 2/2013 Tassaroli E21B 43/1185
 175/2
 2013/0062055 A1 3/2013 Tolman et al.
 2013/0118342 A1 5/2013 Tassaroli
 2013/0199843 A1 8/2013 Ross

2013/0248174 A1 9/2013 Dale et al.
 2014/0131035 A1 5/2014 Entchev et al.
 2015/0136419 A1 5/2015 Mauldin
 2015/0176386 A1 6/2015 Castillo et al.
 2015/0226044 A1* 8/2015 Ursi E21B 43/119
 166/55
 2015/0330192 A1 11/2015 Rogman et al.
 2016/0040520 A1 2/2016 Tolman et al.
 2016/0061572 A1 3/2016 Eitschberger et al.
 2016/0069163 A1 3/2016 Tolman et al.
 2016/0084048 A1 3/2016 Harrigan et al.
 2016/0108722 A1 4/2016 Whitsitt et al.
 2016/0168961 A1 6/2016 Parks et al.
 2016/0202033 A1* 7/2016 Shahinpour E21B 43/1185
 102/206
 2016/0273902 A1 9/2016 Eitschberger
 2016/0290084 A1* 10/2016 LaGrange E21B 29/02
 2016/0298404 A1* 10/2016 Beckett E21B 33/12
 2016/0356132 A1 12/2016 Burmeister et al.
 2017/0030693 A1 2/2017 Preiss et al.
 2017/0052011 A1 2/2017 Parks et al.
 2017/0138150 A1 5/2017 Yenko
 2017/0145798 A1 5/2017 Robey et al.
 2017/0175500 A1 6/2017 Robey et al.
 2017/0211363 A1 7/2017 Bradley et al.
 2017/0241244 A1 8/2017 Barker et al.
 2017/0268860 A1* 9/2017 Eitschberger F42D 1/05
 2017/0276465 A1 9/2017 Parks et al.
 2017/0298716 A1* 10/2017 McConnell E21B 43/119
 2017/0314372 A1 11/2017 Tolman et al.
 2017/0314373 A9 11/2017 Bradley et al.
 2018/0030334 A1 2/2018 Collier et al.
 2018/0080298 A1 3/2018 Covalt et al.
 2018/0119529 A1* 5/2018 Goyeneche E21B 43/117
 2018/0135398 A1 5/2018 Entchev et al.
 2018/0202789 A1 7/2018 Parks et al.
 2018/0202790 A1 7/2018 Parks et al.
 2018/0209251 A1 7/2018 Robey et al.
 2018/0274342 A1 9/2018 Sites
 2018/0299239 A1 10/2018 Eitschberger et al.
 2018/0306010 A1 10/2018 Von Kaenel et al.
 2018/0318770 A1 11/2018 Eitschberger et al.
 2019/0040722 A1 2/2019 Yang et al.
 2019/0048693 A1 2/2019 Henke et al.
 2019/0049225 A1 2/2019 Eitschberger
 2019/0085685 A1 3/2019 McBride
 2019/0162055 A1 5/2019 Collins et al.
 2019/0162056 A1* 5/2019 Sansing F42C 19/06
 2019/0195054 A1 6/2019 Bradley et al.
 2019/0211655 A1 7/2019 Bradley et al.
 2019/0234188 A1* 8/2019 Goyeneche E21B 43/119
 2019/0257158 A1 8/2019 Langford et al.
 2019/0257181 A1 8/2019 Langford et al.
 2019/0284889 A1 9/2019 Lagrange et al.
 2019/0292887 A1 9/2019 Austin, II et al.
 2019/0316449 A1 10/2019 Schultz et al.
 2019/0330947 A1 10/2019 Mulhern et al.
 2019/0338612 A1 11/2019 Holodnak et al.
 2019/0368293 A1 12/2019 Covalt et al.
 2020/0024934 A1 1/2020 Eitschberger et al.
 2020/0024935 A1 1/2020 Eitschberger et al.
 2020/0032626 A1 1/2020 Parks et al.
 2020/0063537 A1* 2/2020 Langford F42D 1/05
 2020/0088011 A1* 3/2020 Eitschberger G01R 27/00
 2020/0182025 A1* 6/2020 Brady E21B 43/11852
 2020/0199983 A1 6/2020 Preiss et al.

FOREIGN PATENT DOCUMENTS

CA 3021913 A1 2/2018
 CN 85107897 A 9/1986
 CN 1082601 C 4/2002
 CN 201209435 3/2009
 CN 101397890 A 4/2009
 CN 201428439 3/2010
 CN 101691837 B 4/2010
 CN 201507296 U 6/2010
 CN 201620848 U 11/2010
 CN 202431259 U 9/2012

(56)

References Cited

FOREIGN PATENT DOCUMENTS

CN	103485750	A	1/2014
CN	103993861	A	8/2014
CN	207847603	U	9/2018
CN	208347755	U	1/2019
CN	208870580	U	5/2019
CN	209195374	U	8/2019
CN	110424930	A	11/2019
CN	209780779	U	12/2019
CN	209908471	U	1/2020
EP	0416915	A2	3/1991
EP	0482969	B1	8/1996
GB	2531450	B	2/2017
GB	2548101	A	9/2017
GB	2548203	A	9/2017
RU	100552	U1	12/2010
RU	2633904	C1	10/2017
WO	2001059401	A1	8/2001
WO	2009091422	A2	7/2009
WO	2012006357	A2	1/2012
WO	2015006869	A1	1/2015
WO	2015134719	A1	9/2015
WO	2015134719	A8	9/2015
WO	2017147329	A1	8/2017
WO	2018009223	A1	1/2018
WO	2019148009	A2	8/2019

OTHER PUBLICATIONS

Dynaenergetics, Electronic Top Fire Detonator, Product Information Sheet, Jul. 30, 2013 1 pg.

German Patent Office, Office Action dated May 22, 2014, in German: See Office Action for German Patent Application No. 10 2013 109 227.6, which is in the same family as PCT Application No. PCT/EP2014/065752, 8 pgs.

PCT Search Report and Written Opinion, dated May 4, 2015: See Search Report and Written opinion for PCT Application No. PCT/EP2014/065752, 12 pgs.

SIPO, Search Report dated Mar. 29, 2017, in Chinese: See Search Report for CN App. No. 201480040456.9, which is in the same family as PCT App. No. PCT/CA2014/050673, 12 & 3 pgs.

Jim Gilliat/Kaled Gasmi, New Select-Fire System, Baker Hughes, Presentation—2013 Asia-Pacific Perforating Symposium, Apr. 29, 2013, 16 pgs., <http://www.perforators.org/presentations.php>.

Dynaenergetics, DYNAslect Electronic Detonator 0015 SFDE RDX 1.4S, Product Information, Dec. 16, 2011, 1 pg.

Dynaenergetics, DYNAslect Electronic Detonator 0015 SFDE RDX 1.4B, Product Information, Dec. 16, 2011, 1 pg.

Norwegian Industrial Property Office, Office Action for NO Patent App. No. 20171759, dated Jan. 14, 2020, 4 pgs.

Norwegian Industrial Property Office, Search Report for NO Patent App. No. 20171759, dated Jan. 14, 2020, 2 pgs.

International Search Report and Written Opinion of International App. No. PCT/EP2019/072064, dated Nov. 20, 2019, 15 pgs.

Baker Hughes, SurePerf Rapid Select-Fire System, Perforate production zones in a single run, Sep. 2012, 2 pgs., www.bakerhughes.com.

GeoDynamics; “STRATX”; promotional brochure; Jan. 30, 2020.

GeoDynamics; “VaporGun”; promotional brochure; Mar. 4, 2020.

GeoDynamics; “Vapr”; promotional brochure; Oct. 1, 2019.

Hunting Energy Services Pte Ltd., “H-1 Perforating Gun System”; promotional brochure; Jun. 21, 2019.

Hunting Energy Services Pte Ltd., “H-2 Perforating System”; promotional brochure; Feb. 12, 2020.

OSO Perforating; “OsoLite”; promotional brochure; Jan. 2019.

SWM International Inc.; “Thunder Disposable Gun System”; promotional brochure; Oct. 2018.

Thilo Scharf; “DynaEnergetics exhibition and product briefing”; pp. 5-6; presented at 2014 Offshore Technology Conference; May 2014.

Thilo Scharf; “DynaState & BTM Introduction”; pp. 4-5, 9; presented at 2014 Offshore Technology Conference; May 2014.

Vigor USA; “Sniper Addressable System”; promotional brochure; Sep. 2019.

Austin Powder Company, A—140 F & Block, Detonator & Block Assembly, 2 pgs.

Owen Oil Tools & Pacific Scientific; Side Block for Side Initiation, 1 pg.

SIPO, Office Action dated Jun. 27, 2018: See Office Action for CN App. No. 201580011132.7, which is in the same family as PCT App. No. PCT/US2015/18906, 9 pgs. & 5 pgs.

Amit Govil, Selective Perforation: A Game Changer in Perforating Technology—Case Study, presented at the 2012 European and West African Perforating Symposium, Schlumberger, Nov. 7-9, 2012, 14 pgs.

Dynaenergetics, DYNAslect System, information downloaded from website, Jul. 3, 2013, 2 pgs., <http://www.dynaenergetics.com/>.

GB Intellectual Property Office, Search Report for App. No. GB 1700625.5, which is in the same family as U.S. Pat. No. 9494021, dated Jul. 7, 2017, 5 pgs.

International Search Report and Written Opinion of International Application No. PCT/US2015/018906, Jul. 10, 2015, 12 pgs.

Dynaenergetics, Gun Assembly, Products Summary Sheet, May 7, 2004, 1 pg.

GB Intellectual Property Office, Office Action dated Feb. 27, 2018, See Office Action for App. No. GB 1717516.7, which is the same family as PCT App. No. PCT/CA2014/050673, 6 pg.

Dynaenergetics, Selective Perforating Switch, information downloaded from website, Jul. 3, 2013, 2 pgs., <http://www.dynaenergetics.com/>.

Hunting Titan, Wireline Top Fire Detonator Systems, Product Information Sheet, 1 pg.

Hunting Titan Inc., Petition for Inter Parties Review of U.S. Pat. No. 9581422, filed Feb. 16, 2018, 93 pgs.

Dynaenergetics GMBH & Co. KG, Patent Owner’s Response to Hunting Titan’s Petition for Inter Parties Review, filed Dec. 6, 2018, 73 pgs.

Dynaenergetics GMBH & Co. KG, Patent Owner’s Motion to Amend, filed Dec. 6, 2018, 53 pgs.

U.S. Patent Trial and Appeal Board, Institution of Inter Partes Review, Case IPR2018-00600, issued on Aug. 21, 2018, 9 pgs.

International Written Opinion of International Application No. PCT/CA2014/050673, dated Oct. 9, 2014, 4 pgs.

International Search Report of International Application No. PCT/CA2014/050673, dated Oct. 9, 2014, 3 pgs.

UK Examination Report of United Kingdom Patent Application No. GB1600085.3, which is in the same family as U.S. Pat. No. 9,494,021, dated Mar. 9, 2016, 1 pg.

FIIP, Search Report dated Feb. 1, 2018, in Russian: See Search Report for RU App. No. 2016104882/03, which is in the same family as PCT App. No. PCT/CA2014/050673, 7 pgs.

FIIP, Search Report dated Feb. 1, 2018, in English See Search Report for RU App. No. 2016104882/03, which is in the same family as PCT App. No. PCT/CA2014/050673, 4 pages.

Norwegian Industrial Property Office, Office Action for NO Patent App. No. 20160017, which is in the same family as PCT App. No. PCT/CA2014/050673, dated Jun. 15, 2017, 3 pgs.

Jet Research Center Inc., Red RF Safe Detonators Brochure, 2008, 2 pgs., www.jetresearch.com.

Jet Research Center Inc., JRC Catalog, 36 pgs., www.jetresearch.com.

Horizontal Wireline Services, Presentation of a completion method of shale demonstrated through an example of Marcellus Shale, Pennsylvania, USA, Presented at 2012 International Perforating Symposium (Apr. 26-28, 2012), 17 pages.

Smylie, New Safe and Secure Detonators for the Industry’s consideration, Presented at Explosives Safety & Security Conference Marathon Oil Co, Houston, Feb. 23-24, 2005, 20 pages.

Schlumberger, Combining and Customizing Technologies for Perforating Horizontal Wells in Algeria, Presented at 2011 MENAPS Middle East and North Africa Perforating Symposium, Nov. 28-30, 2011, 20 pages.

Baker Hughes, Long Gun Deployment Systems IPS-12-28, Presented at 2012 International Perforating Symposium, Apr. 26-28, 2011, 11 pages.

(56)

References Cited

OTHER PUBLICATIONS

Owen Oil Tools, Recommended Practice for Oilfield Explosive Safety, Presented at 2011 MENAPS Middle East and North Africa Perforating Symposium, Nov. 28-30, 2011, 6 pages.

Norwegian Industrial Property Office, Search Report for NO Patent App. No. 20160017, which is in the same family as PCT App No. PCT/CA2014/050673, dated Jun. 15, 2017, 2 pgs.

Intellectual Property India, Office Action of IN Application No. 201647004496, dated Jun. 7, 2019, which is in the same family as PCT App No. PCT/CA2014/050673, 6 pgs.

United States Patent and Trademark Office, Non-final Office Action of U.S. Appl. No. 16/455,816, dated Nov. 5, 2019, 17 pgs.

United States Patent and Trademark Office, Non-final Office Action of U.S. Appl. No. 16/451,440, dated Oct. 24, 2019, 22 pgs.

United States Patent and Trademark Office, Non-final Office Action of U.S. Appl. No. 16/542,890, dated Nov. 4, 2019, 16 pgs.

U.S. Appl. No. 29/733,080, filed Apr. 29, 2020, Frank Haron Preiss. Gore Lab, ZERO180™ Gun System Assembly and Arming Procedures, 2015, 33 pgs., <https://www.corelab.com/owen/CMS/docs/Manuals/gunsys/zero180/MAN-Z180-000.pdf>.

DynaEnergetics GmbH & Co. KG; Case No. IPR2018-00600; Patent Owner's Motion to Amend; filed Dec. 6, 2018, 53 pgs.

Dynaenergetics; DynaStage Solution—Factory Assembled Performance-Assured Perforating Systems; 6 pages.

Eric H. Findlay, Jury Trial Demand in Civil Action No. 6:20-cv-00069-ADA, dated Apr. 22, 2020, 32 pages.

Gilliat et al.; New Select-Fire System: Improved Reliability and Safety in Select Fire Operations; 2012; 16 pgs.

Hunting Energy Service, ControlFire RF Safe ControlFire® RF-Safe Manual, 33 pgs., Jul. 2016, http://www.hunting-intl.com/media/2667160/ControlFire%20RF_Assembly%20Gun%20Loading_Manual.pdf.

Hunting Titan, H-1® Perforating Gun System, 2016, 2 pgs., <http://www.hunting-intl.com/titan>.

Jet Research Center, Velocity™ Perforating System Plug and Play Guns for Pumpdown Operation, Ivarado, Texas, Jul. 2019, 8 pgs., <https://www.jetresearch.com/content/dam/jrc/Documents/Brochures/jrc-velocity-perforating-system.pdf>.

Owen Oil Tools, E & B Select Fire Side Port, Tandem Sub, Apr. 2020, 2 pgs., https://www.corelab.com/owen/cms/docs/Canada/10A_eandbsystem-01.0-c.pdf.

Owen Oil Tools, Expendable Perforating Guns, Jul. 2008, 7 pgs., https://www.corelab.com/owen/cms/docs/Canada/10A_erhsc-01.0-c.pdf.

Owen Oil Tools, E & B Select Fire Side Port Tandem Sub Assembly, 2009, 9 pgs., <https://www.corelab.com/owen/CMS/docs/Manuals/gunsys/MAN-30-XXX-0002-96-R00.pdf>.

Robert Parrott, Case IPR2018-00600 for U.S. Pat. No. 9,581,422 B2, Declaration regarding Patent Invalidity, dated Jun. 29, 2020, 146 pages.

Schulumberger, Perforating Services Catalog, 2008, 521 pages.

State Intellectual Property Office, P.R. China; First Office Action with full translation for CN App. No. 201480040456.9; dated Mar. 29, 2017; 12 pages (English translation 17 pages).

United States Patent and Trademark Office, Case IPR2018-00600 for U.S. Pat. No. 9,581,422 B2, DynaEnergetics GmbH & Co. KG's Patent Owner Preliminary Response, dated May 22, 2018, 47 pgs.

United States Patent and Trademark Office, Case IPR2018-00600 for U.S. Pat. No. 9,581,422 B2, Petitioner's Reply in Inter Partes Review of Patent No. 9,581,422, dated Mar. 7, 2019, 44 pgs.

United States Patent and Trademark Office, Case PGR 2020-00072 for U.S. Pat. No. 10,429,161 B2, Petition for Post Grant Review of Claims 1-20 of U.S. Pat. No. 10,429,161 Under 35 U.S.C. §§ 321-28 and 37 C.F.R. §§42.200 ET SEQ., dated Jun. 30, 2020, 109 pages.

United States Patent and Trademark Office, Final Written Decision of Case IPR2018-00600 for U.S. Pat. No. 9,581,422 B2, Paper No. 42, dated Aug. 20, 2019, 31 pgs.

United States Patent and Trademark Office, Non-final Office Action of U.S. Appl. No. 16/455,816, dated Jul. 2, 2020, 15 pgs.

United States Patent and Trademark Office, Office Action of U.S. Appl. No. 16/585,790, dated Nov. 12, 2019, 9 pgs.

United States Patent and Trademark Office, Office Action of U.S. Appl. No. 16/858,041, dated Jun. 16, 2020, 11 pgs.

United States Patent and Trademark Office, Office Action of U.S. Appl. No. 29/733,325, dated Jun. 26, 2020, 9 pgs.

Vigor, Perforating Gun Accessories, China Vigor Drilling Oil Tools and Equipment Co., Ltd., Sep. 14, 2018, 4 pgs., <http://www.vigordrilling.com/completion-tools/perforating-gun-accessories.html>.

Yellow Jacket Oil Tools, Orienting Sub, 2019, 2 pgs., <https://www.yjoiltools.com/Wireline-Subs/Orienting-Sub>.

Yellow Jacket Oil Tools; Tandem Sub; 2019; 3 pages.

GE Oil & Gas; Pipe Recovery Technology & Wireline Accessories; pp. 317-18, 330, 381-82; 2013 (435 pages).

Jet Research Center, Plugs and Setting Tools, Alvarado, Texas, 13 pgs., www.jetresearch.com/content/dam/jrc/Documents/Books_Catalogs/02_Plugs_STNG_Tool.pdf.

United States Patent and Trademark Office, U.S. Appl. No. 61/733,129; filed Dec. 4, 2012; 10 pages.

United States Patent and Trademark Office, U.S. Appl. No. 61/819,196; filed May 3, 2013 ; 10 pages.

* cited by examiner

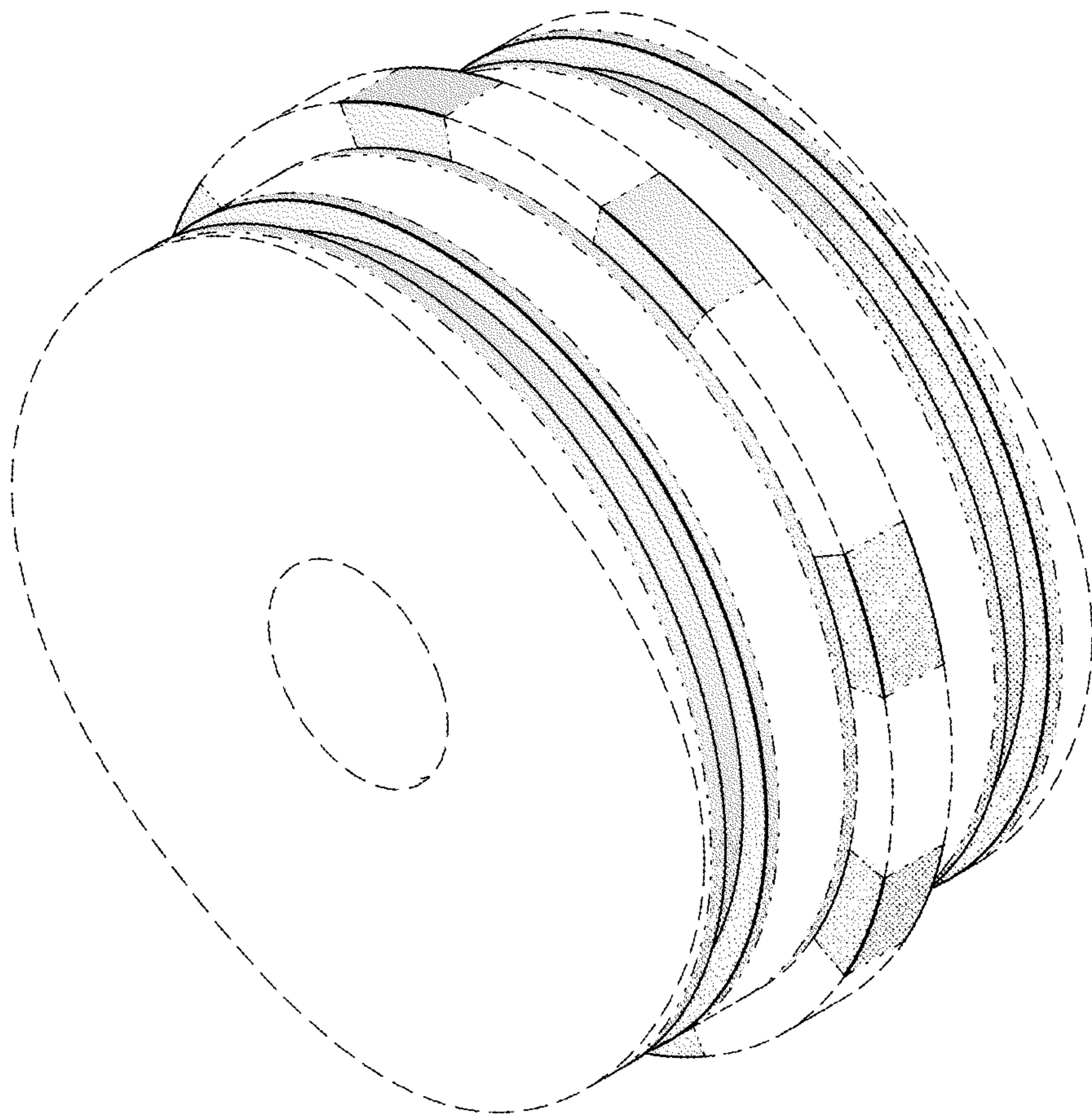

FIG. 1

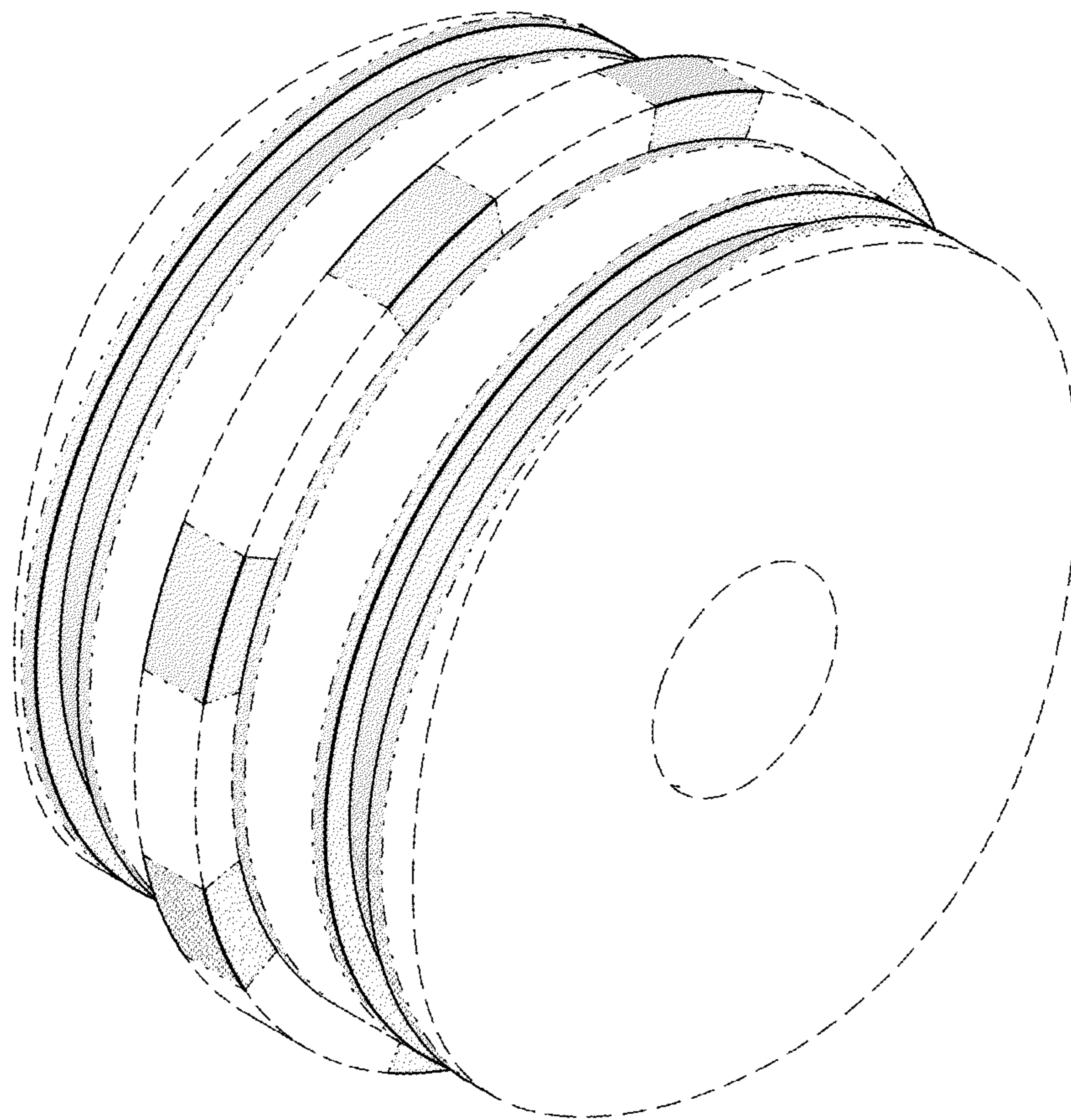

FIG. 2

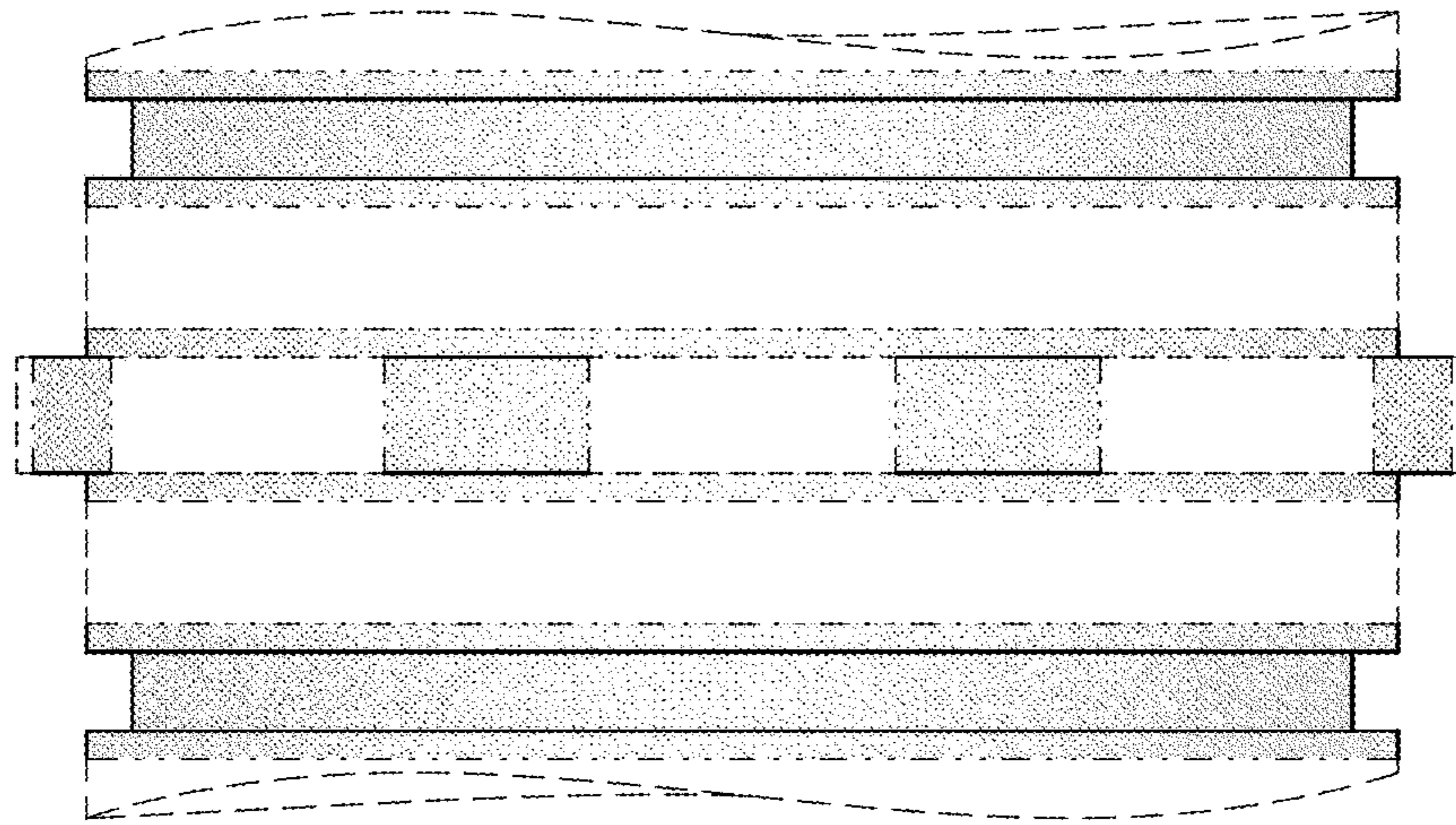

FIG. 3

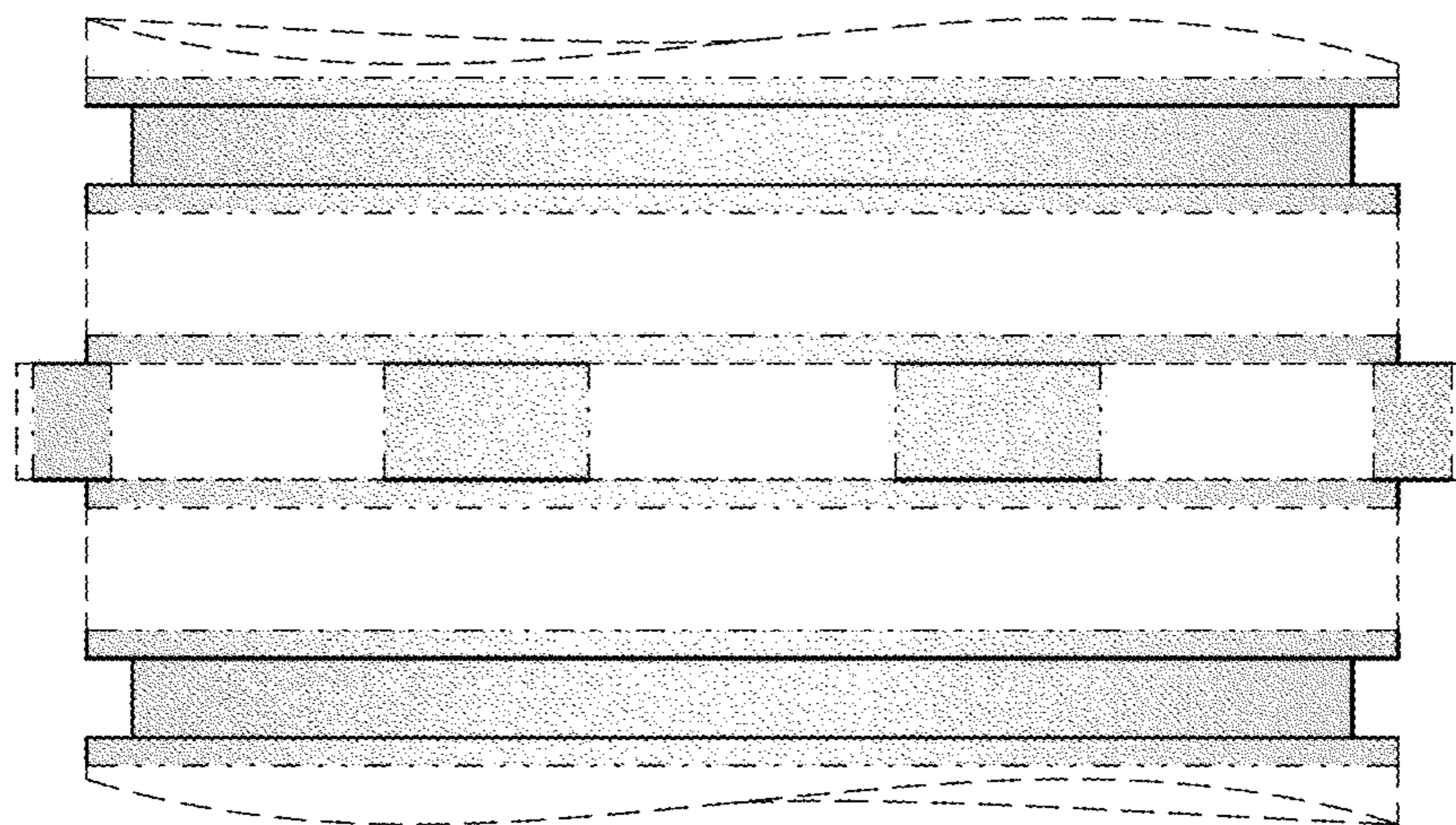

FIG. 4

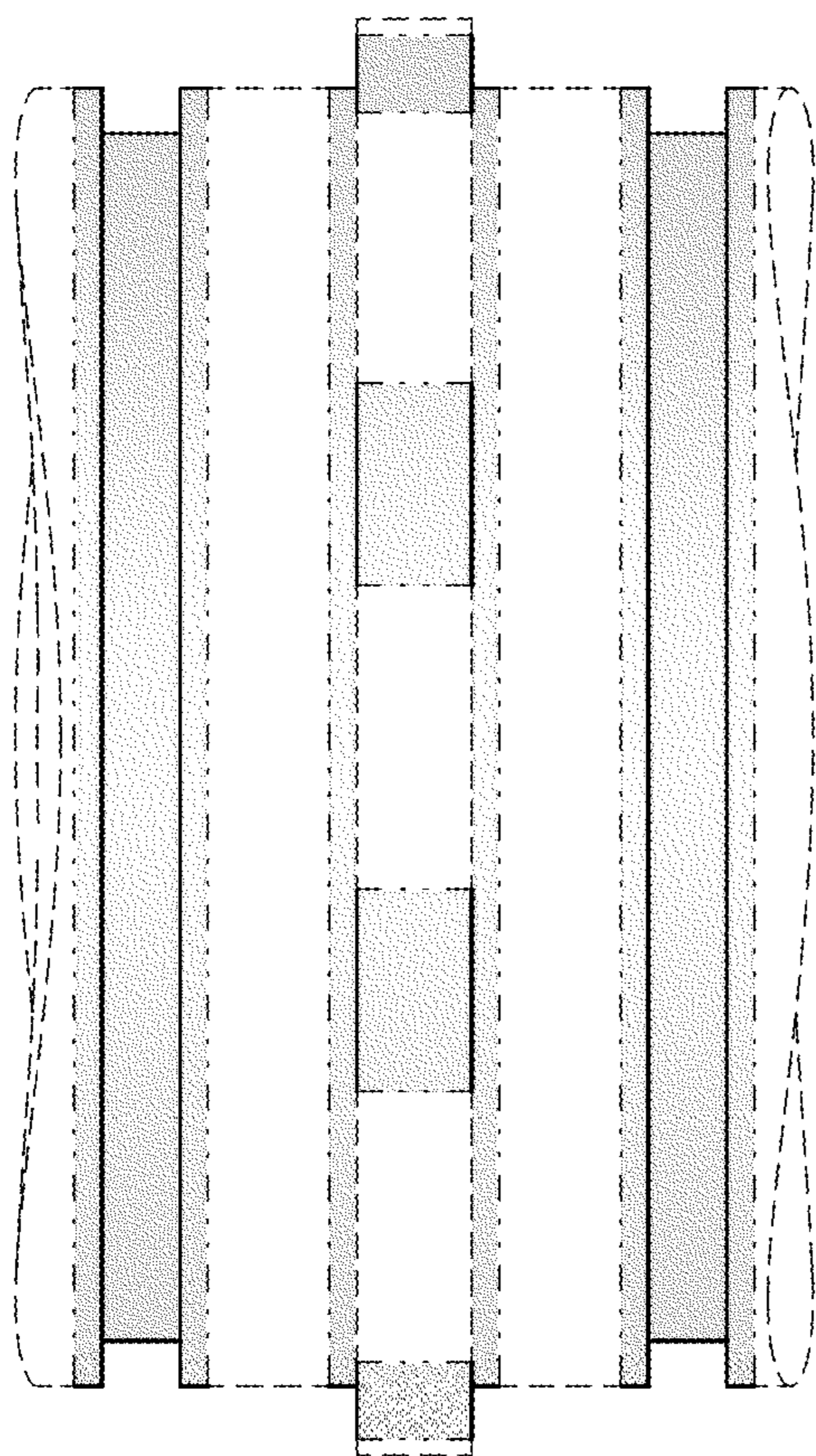

FIG. 5

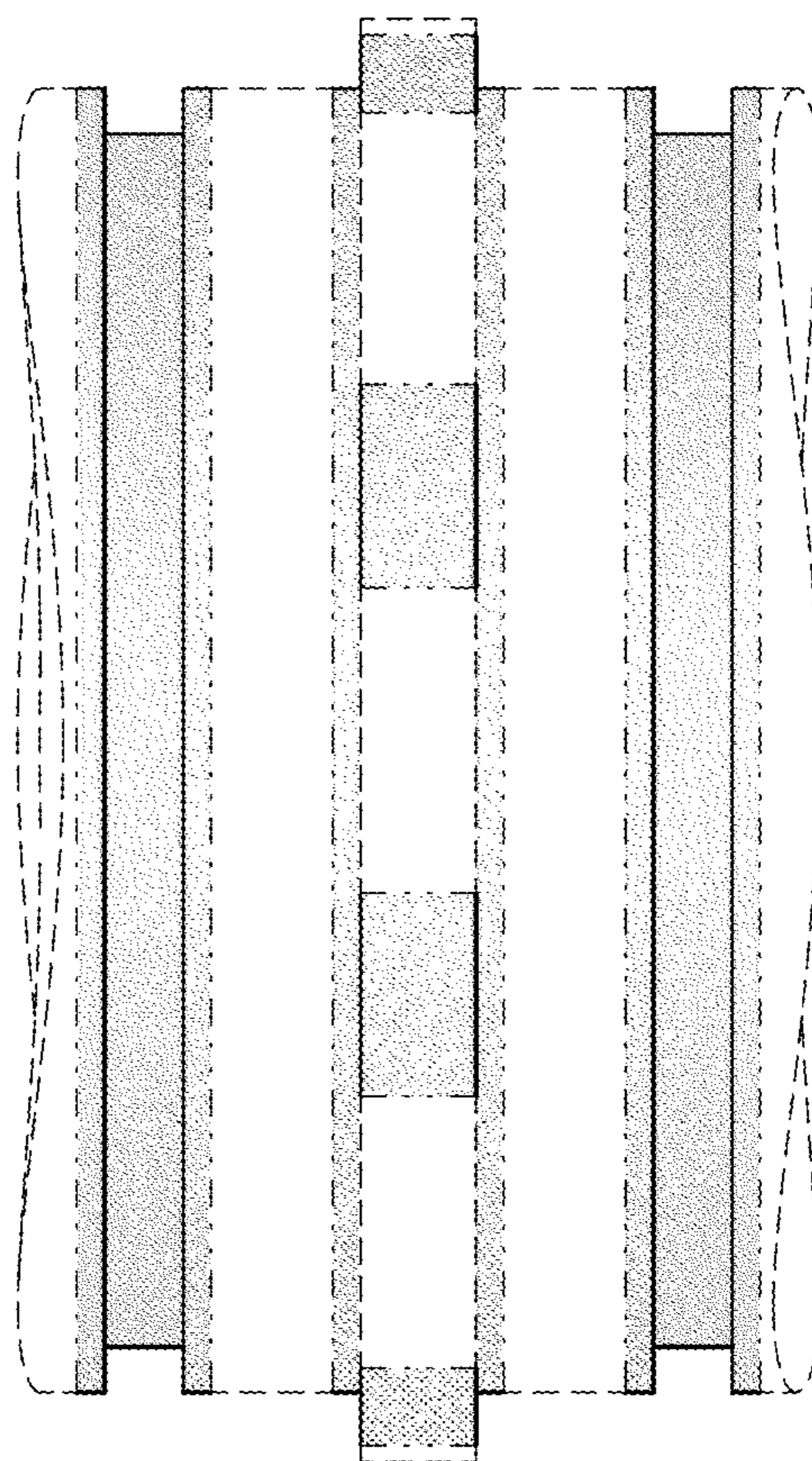

FIG. 6

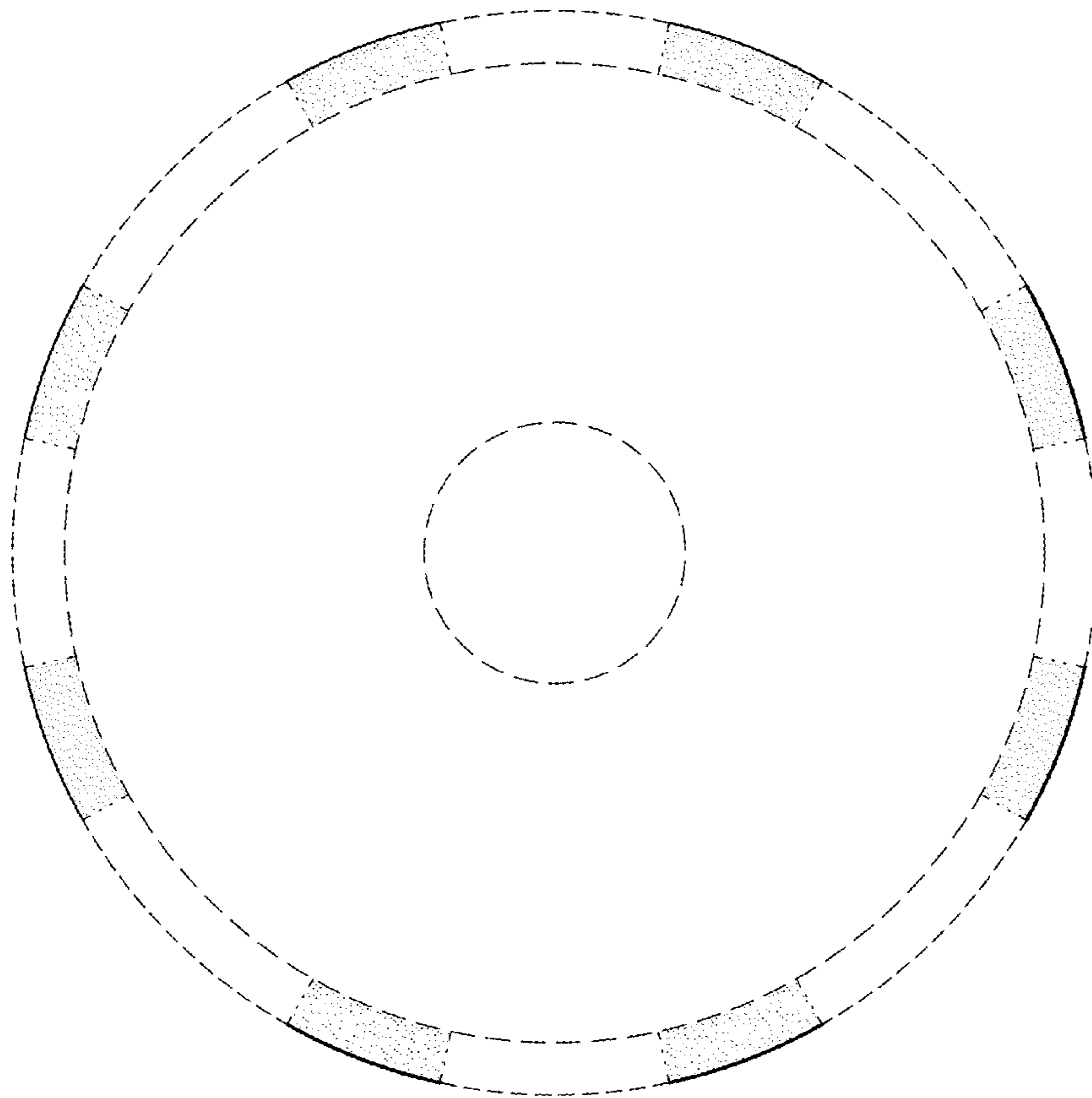

FIG. 7

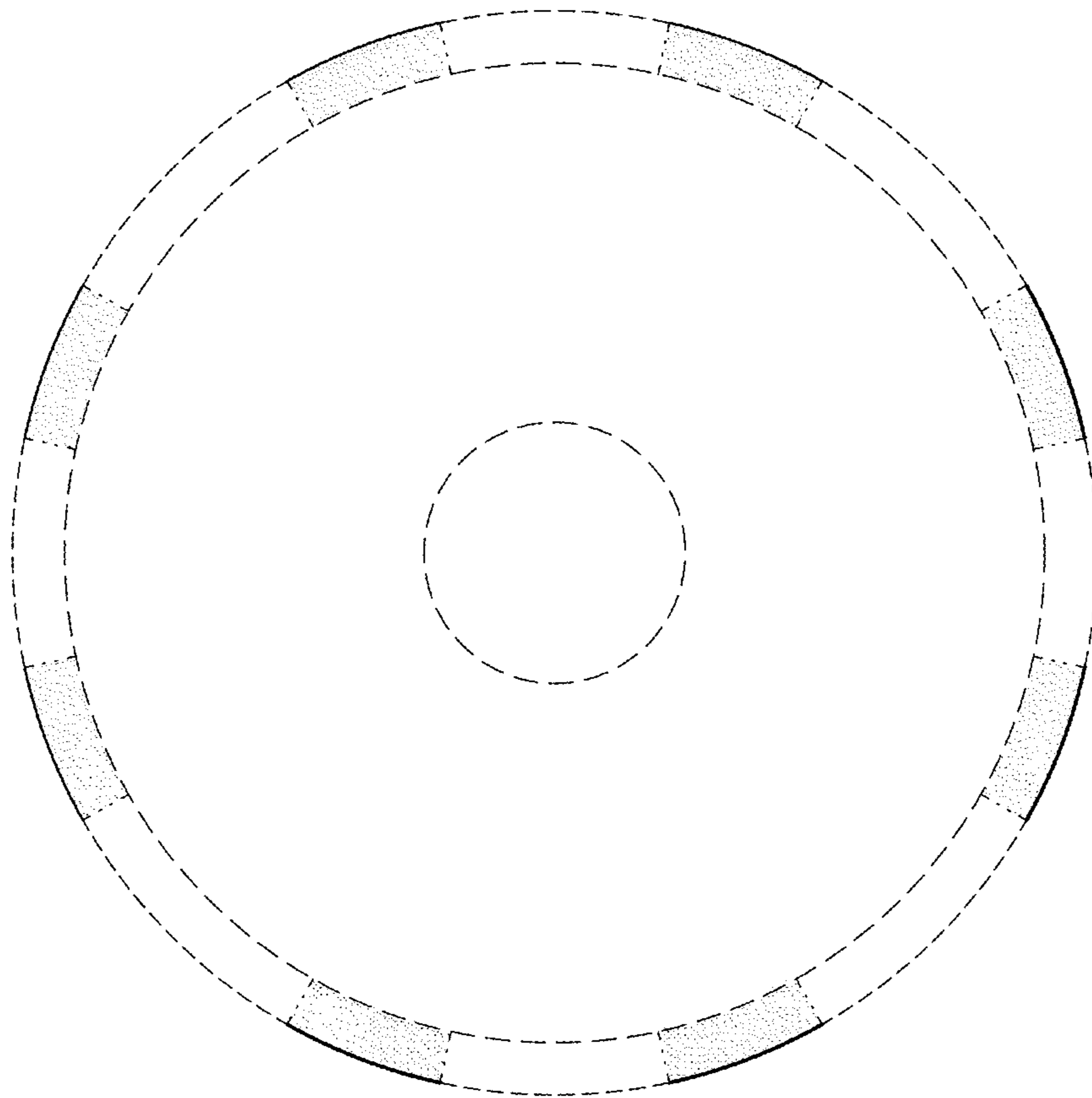

FIG. 8

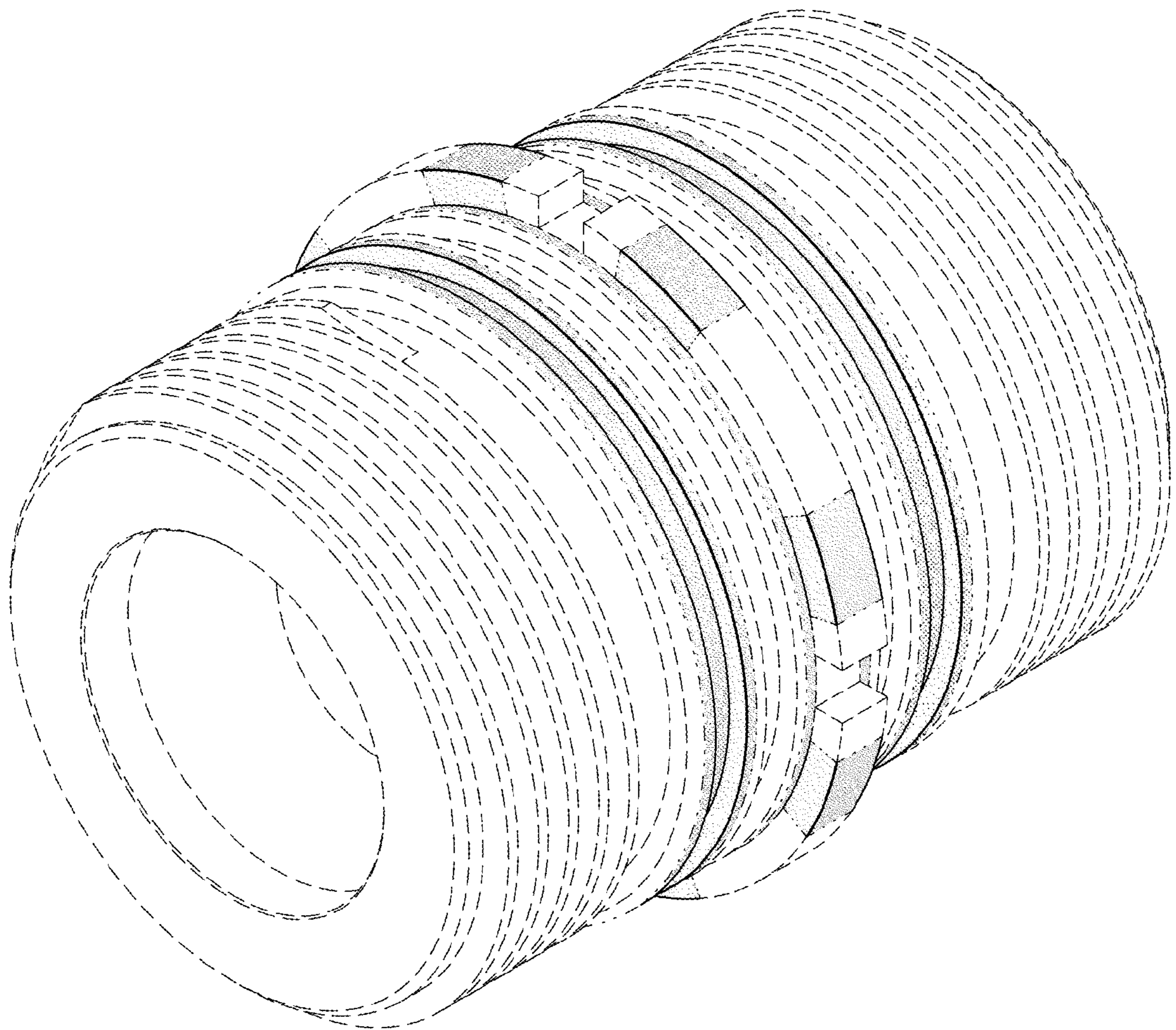

FIG. 9

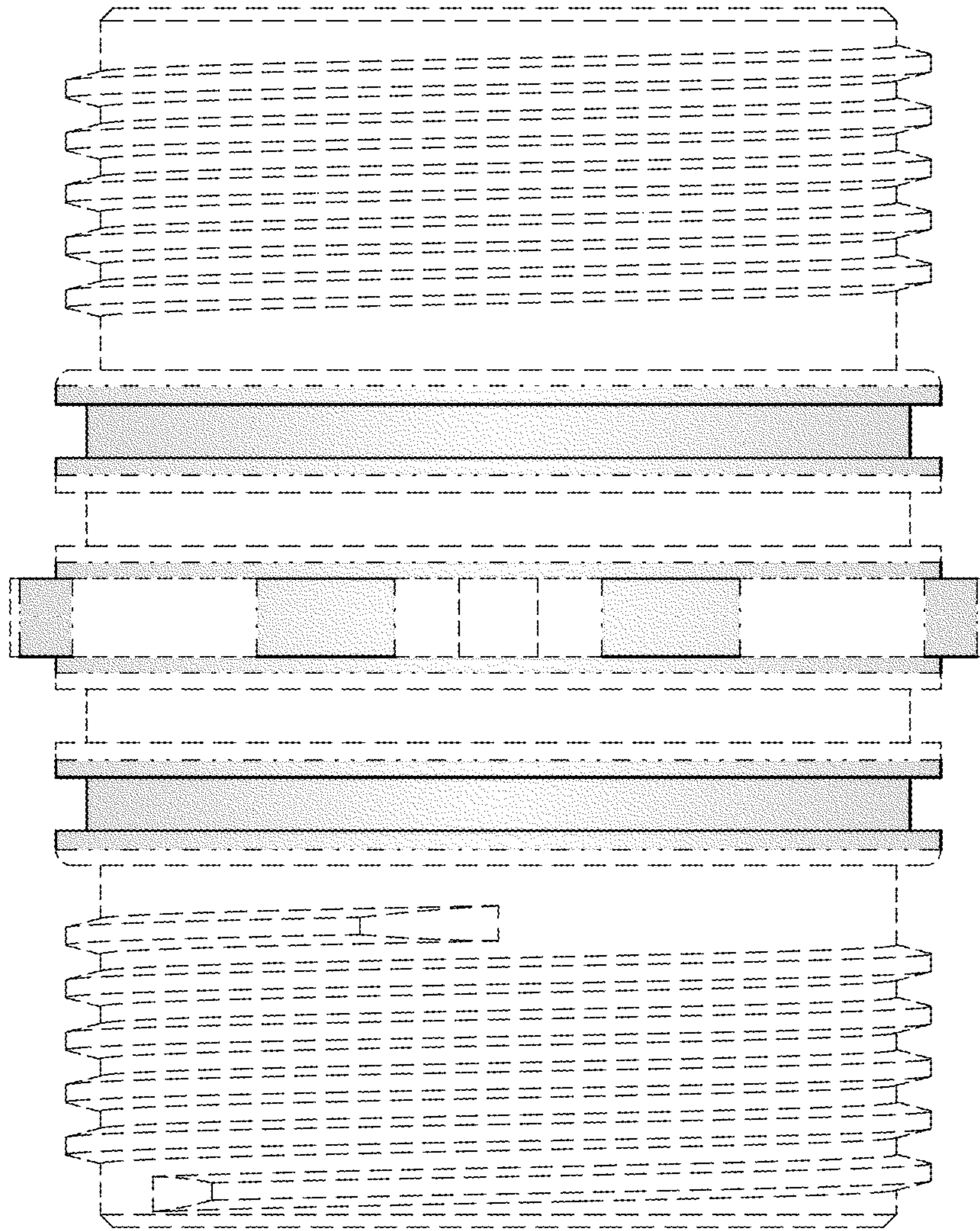

FIG. 10

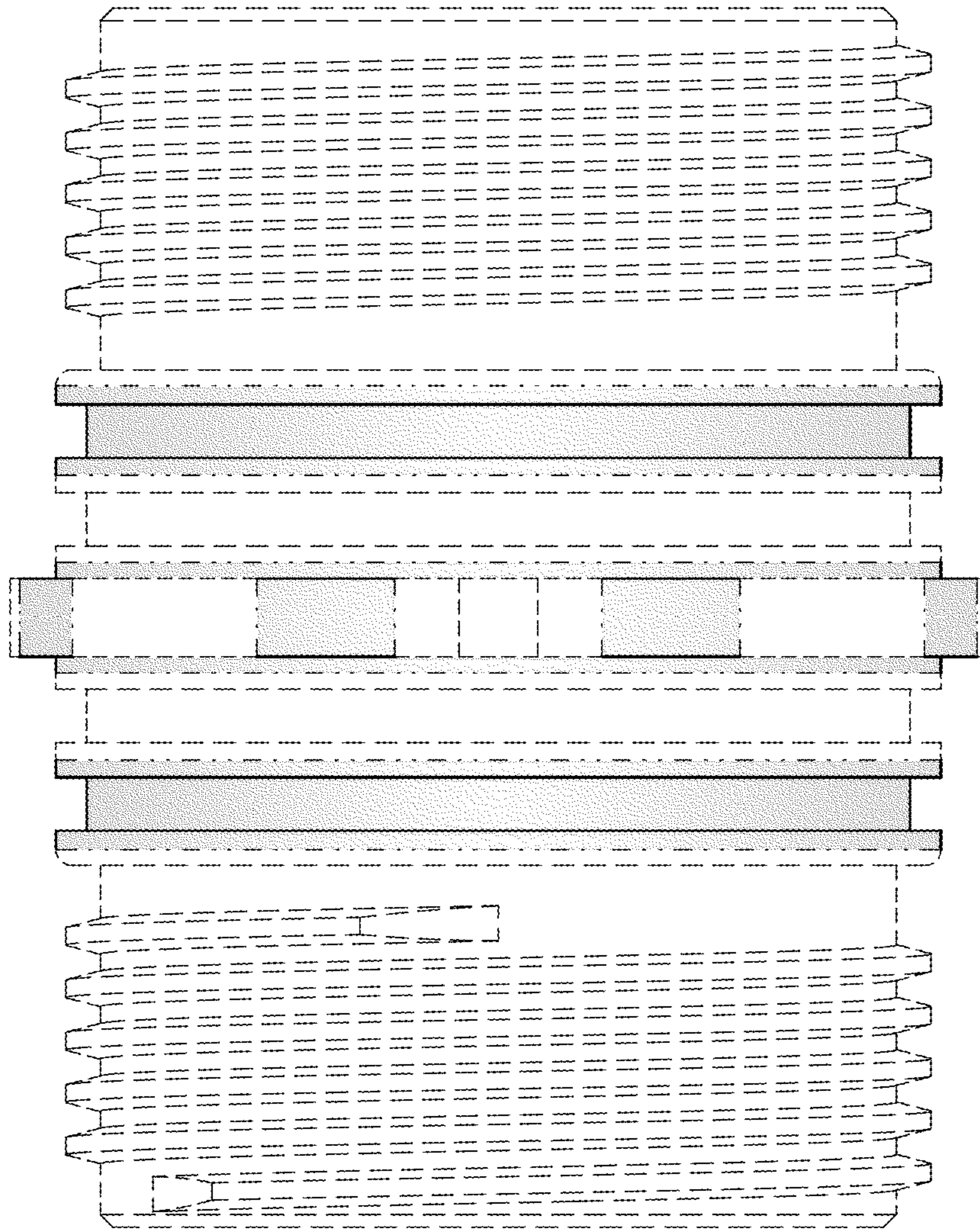

FIG. 11

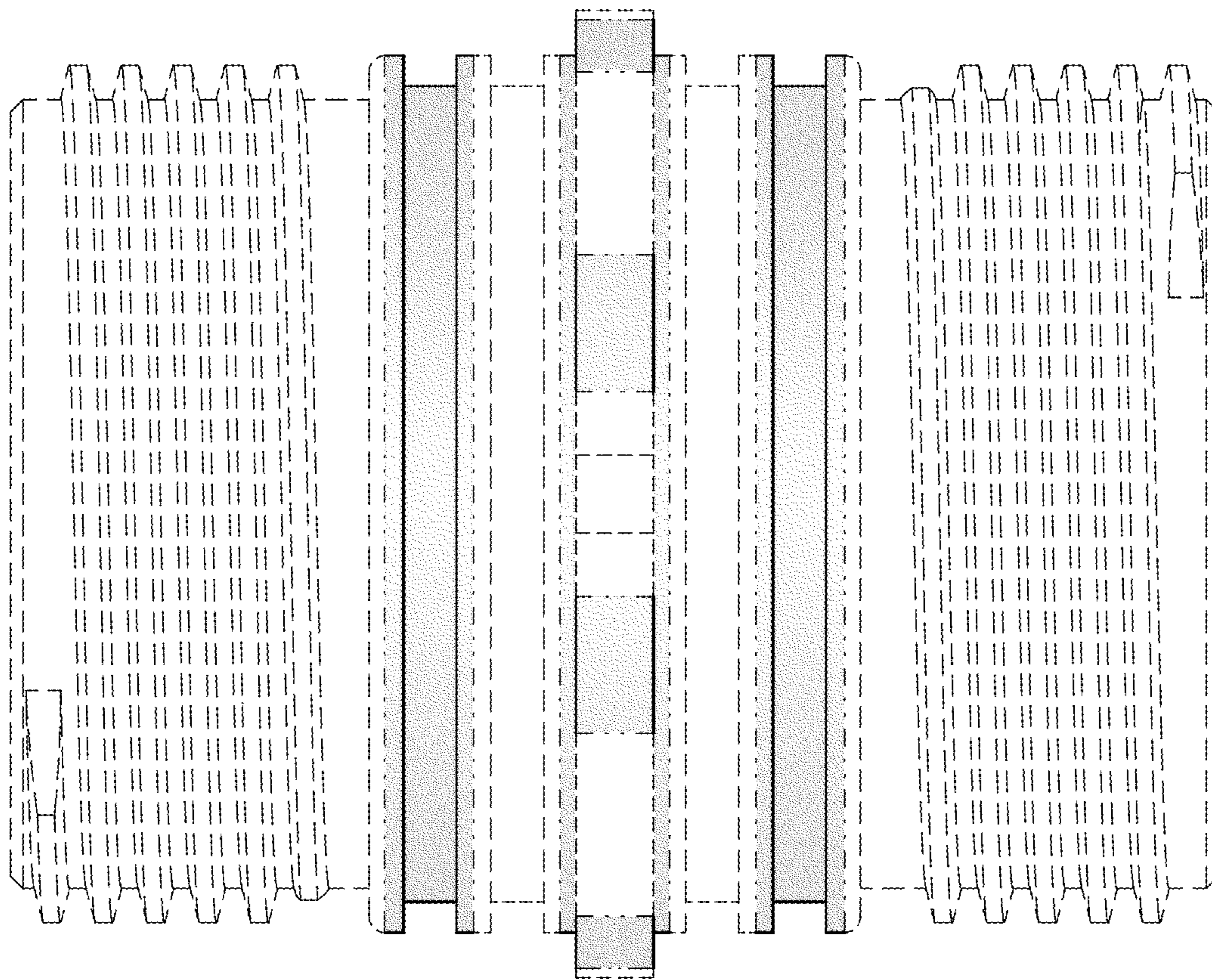

FIG. 12

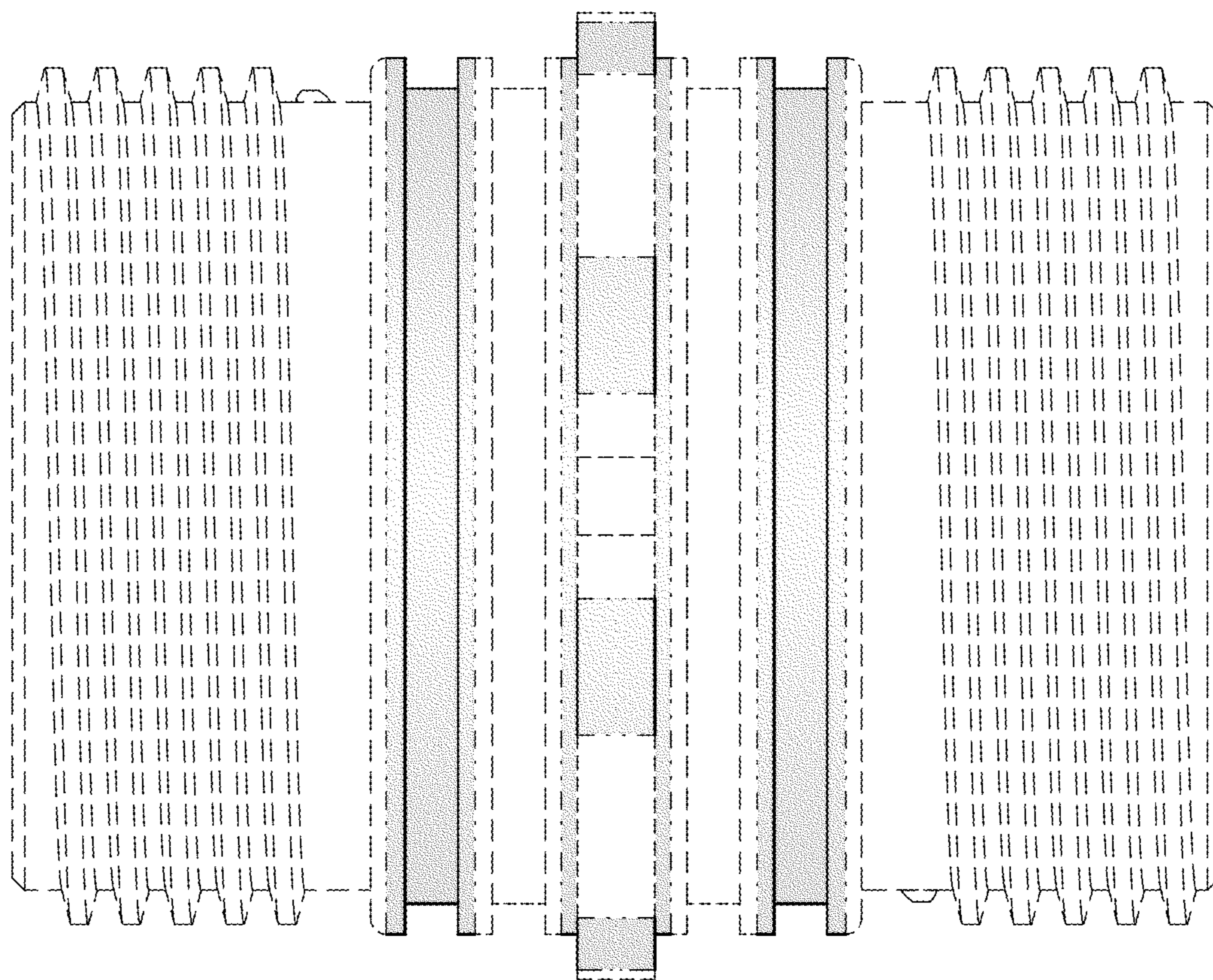

FIG. 13

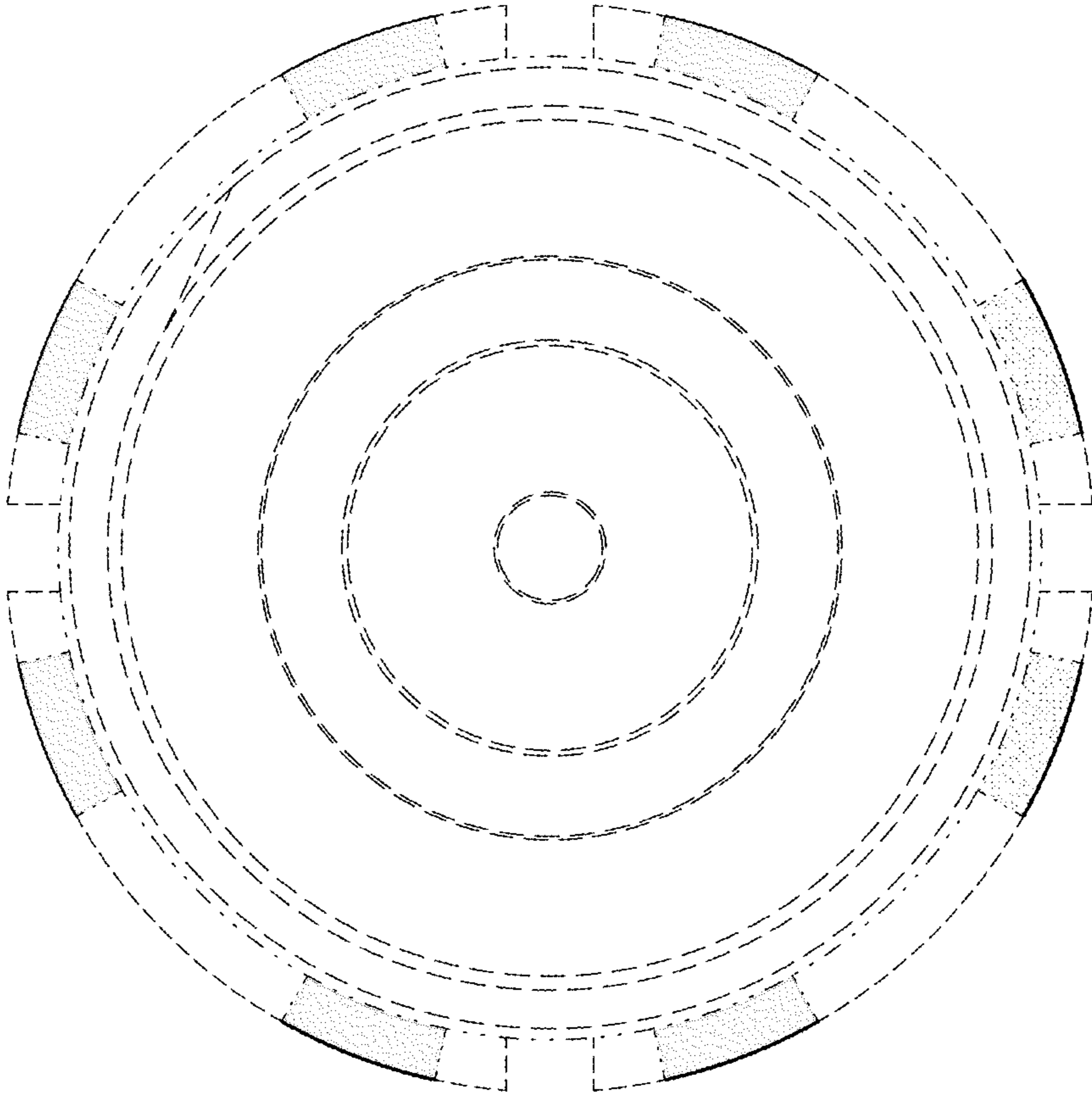

FIG. 14

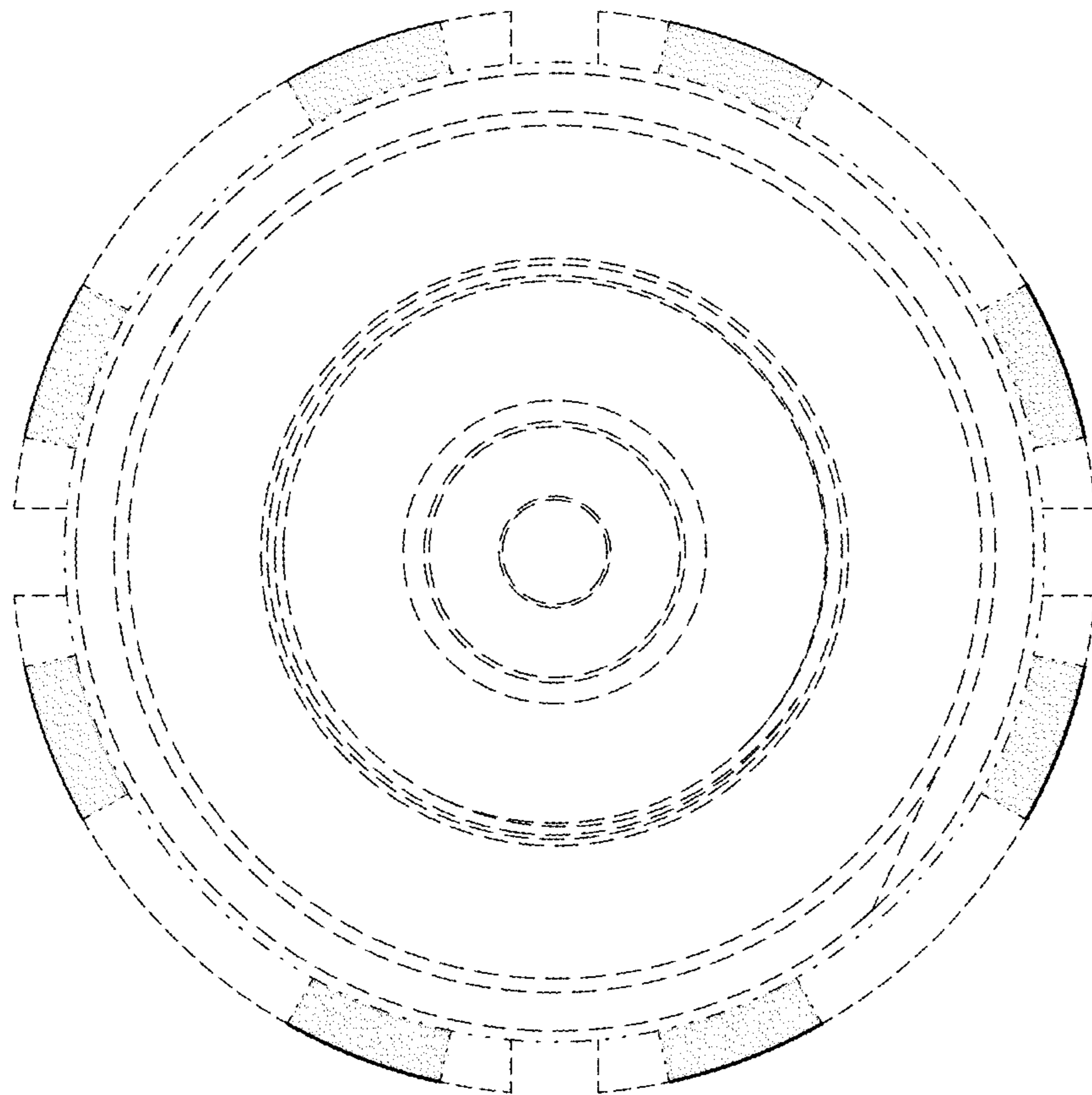

FIG. 15