



US00D904355S

(12) **United States Design Patent** (10) **Patent No.:** **US D904,355 S**  
**Horn** (45) **Date of Patent:** **\*\* Dec. 8, 2020**

(54) **RADIO MODULE**

(71) Applicant: **Gemalto M2M GmbH**, Berlin (DE)

(72) Inventor: **Annette Horn**, Berlin (DE)

(73) Assignee: **Gemalto M2M GmbH**, Berlin (DE)

(\*\*) Term: **15 Years**

(21) Appl. No.: **29/662,782**

(22) Filed: **Sep. 7, 2018**

**Related U.S. Application Data**

(62) Division of application No. 29/567,639, filed on Jun. 10, 2016, now Pat. No. Des. 831,009.

(30) **Foreign Application Priority Data**

Dec. 11, 2015 (EM) ..... 00290534900010008

(51) **LOC (12) Cl.** ..... **14-03**

(52) **U.S. Cl.**  
USPC ..... **D14/230**; D13/182; D14/240

(58) **Field of Classification Search**  
USPC ..... D14/356, 357, 358, 361, 362, 365, 367,  
D14/370, 388, 432, 434, 203.1, 203.6,  
(Continued)

(56) **References Cited**

**U.S. PATENT DOCUMENTS**

D530,708 S \* 10/2006 Maruyama ..... D14/240  
D533,546 S 12/2006 Iizuka et al.  
(Continued)

**OTHER PUBLICATIONS**

Gemalto M2M GmbH, "Cinterion® PLS8 Wireless Module," Product Data Sheet, Preliminary Version, 2013, 4 pages.  
(Continued)

(74) *Attorney, Agent, or Firm* — Seed IP Law Group  
LLP; Jared M. Barrett

(57) **CLAIM**

The ornamental design for a radio module, substantially as shown and described.

**DESCRIPTION**

FIG. 1 is a front elevational view of a radio module, showing a first embodiment of my new design;  
FIG. 2 is a rear perspective view thereof;  
FIG. 3 is a rear elevational view thereof.  
FIG. 4 is a front elevational view of a radio module, showing a second embodiment of my new design;  
FIG. 5 is a side elevational view thereof;  
FIG. 6 is a bottom plan view thereof;  
FIG. 7 is a rear perspective view thereof;  
FIG. 8 is a rear elevational view thereof.  
FIG. 9 is a front elevational view of a radio module, showing a third embodiment of my new design;  
FIG. 10 is a rear perspective view thereof;  
FIG. 11 is a rear elevational view thereof.  
FIG. 12 is a front elevational view of a radio module, showing a fourth embodiment of my new design;  
FIG. 13 is a side elevational view thereof;  
FIG. 14 is a bottom plan view thereof;  
FIG. 15 is a rear perspective view thereof;  
FIG. 16 is a rear elevational view thereof.  
FIG. 17 is a front elevational view of a radio module, showing a fifth embodiment of my new design;  
FIG. 18 is a rear perspective view thereof;  
FIG. 19 is a rear elevational view thereof.  
FIG. 20 is a front elevational view of a radio module, showing a sixth embodiment of my new design;  
FIG. 21 is a side elevational view thereof;  
FIG. 22 is a bottom plan view thereof;  
FIG. 23 is a rear perspective view thereof; and,  
FIG. 24 is a rear elevational view thereof.  
The broken lines in the drawings depict parts of the radio module that form no part of the claimed design.

*Primary Examiner* — Marie D. Fast Horse

**1 Claim, 24 Drawing Sheets**

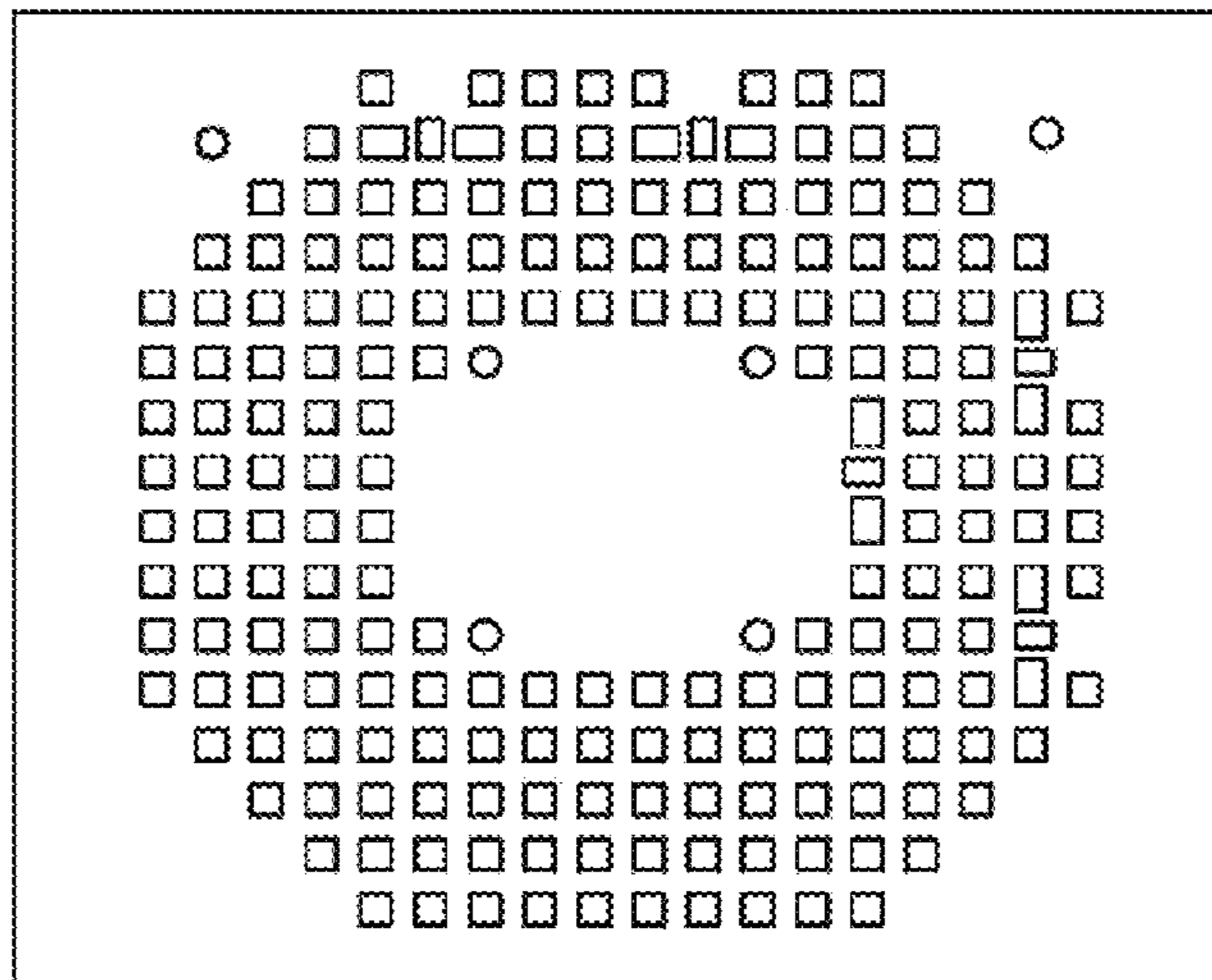

(58) **Field of Classification Search**  
 USPC ..... D14/204, 205, 216, 240, 242, 299, 125,  
 D14/129, 130, 140, 155, 168, 188, 195,  
 D14/300, 302, 314, 348, 351, 496, 230,  
 D14/137, 433; D13/182, 147;  
 D10/104.1, 106.9  
 CPC ..... H01Q 1/241; H01Q 1/243; H04B 1/38;  
 H04W 88/02; H04W 88/06; H04M  
 1/0254; H04M 1/0256; H04L 9/0877  
 See application file for complete search history.

(56) **References Cited**

U.S. PATENT DOCUMENTS

D540,272 S \* 4/2007 Higashibata ..... D13/182  
 D582,400 S 12/2008 Takisawa et al.  
 D605,642 S 12/2009 Yakubo  
 D645,029 S 9/2011 Yakubo et al.  
 D655,697 S 3/2012 Petsch  
 D660,828 S 5/2012 Petsch  
 D668,638 S 10/2012 Matsumoto et al.  
 D668,639 S 10/2012 Matsumoto et al.  
 D668,640 S 10/2012 Matsumoto et al.  
 D699,201 S 2/2014 Petsch  
 D704,155 S 5/2014 Chang et al.  
 D730,304 S 5/2015 Matsumoto et al.  
 D732,487 S 6/2015 Lai et al.  
 D732,488 S 6/2015 Lai et al.  
 D733,104 S 6/2015 Yang  
 D737,778 S \* 9/2015 Druscovich ..... D13/147

D737,779 S \* 9/2015 Druscovich ..... D13/147  
 D738,867 S 9/2015 Zuniga  
 D753,604 S \* 4/2016 Druscovich ..... D13/147  
 D757,693 S 5/2016 Sudo et al.  
 D764,424 S 8/2016 Matsumoto et al.  
 9,432,298 B1 8/2016 Smith  
 D768,115 S 10/2016 Kazanchian  
 D778,850 S 2/2017 Matsumoto et al.  
 D778,851 S 2/2017 Matsumoto et al.  
 D778,852 S 2/2017 Matsumoto et al.  
 D784,341 S \* 4/2017 Kim ..... D14/433  
 D784,342 S \* 4/2017 Kim ..... D14/433  
 D800,665 S \* 10/2017 Druscovich ..... D13/147  
 D801,277 S \* 10/2017 Druscovich ..... D13/147  
 D821,331 S \* 6/2018 Druscovich ..... D13/147  
 D830,348 S \* 10/2018 Sudo ..... D14/230  
 D831,009 S \* 10/2018 Horn ..... D14/230  
 D841,589 S \* 2/2019 Bohmer ..... D13/133  
 10,461,428 B2 \* 10/2019 Jeong ..... H01Q 1/243  
 D872,032 S \* 1/2020 Morelli ..... D13/147  
 D872,033 S \* 1/2020 Morelli ..... D13/147  
 2009/0197394 A1 8/2009 Parekh  
 2011/0051375 A1 3/2011 Ammar  
 2012/0142398 A1 6/2012 Tamaoka

OTHER PUBLICATIONS

Questel, Radio Modules Designs, Nov. 12, 2010, URL=<https://sobjprd.questel.fr/export/QPTUJ214/pdf2/063b08b2-2144-4b5a-8aef-7a979da05710-175859.pdf>, download date Jul. 21, 2017, 108 pages.

\* cited by examiner

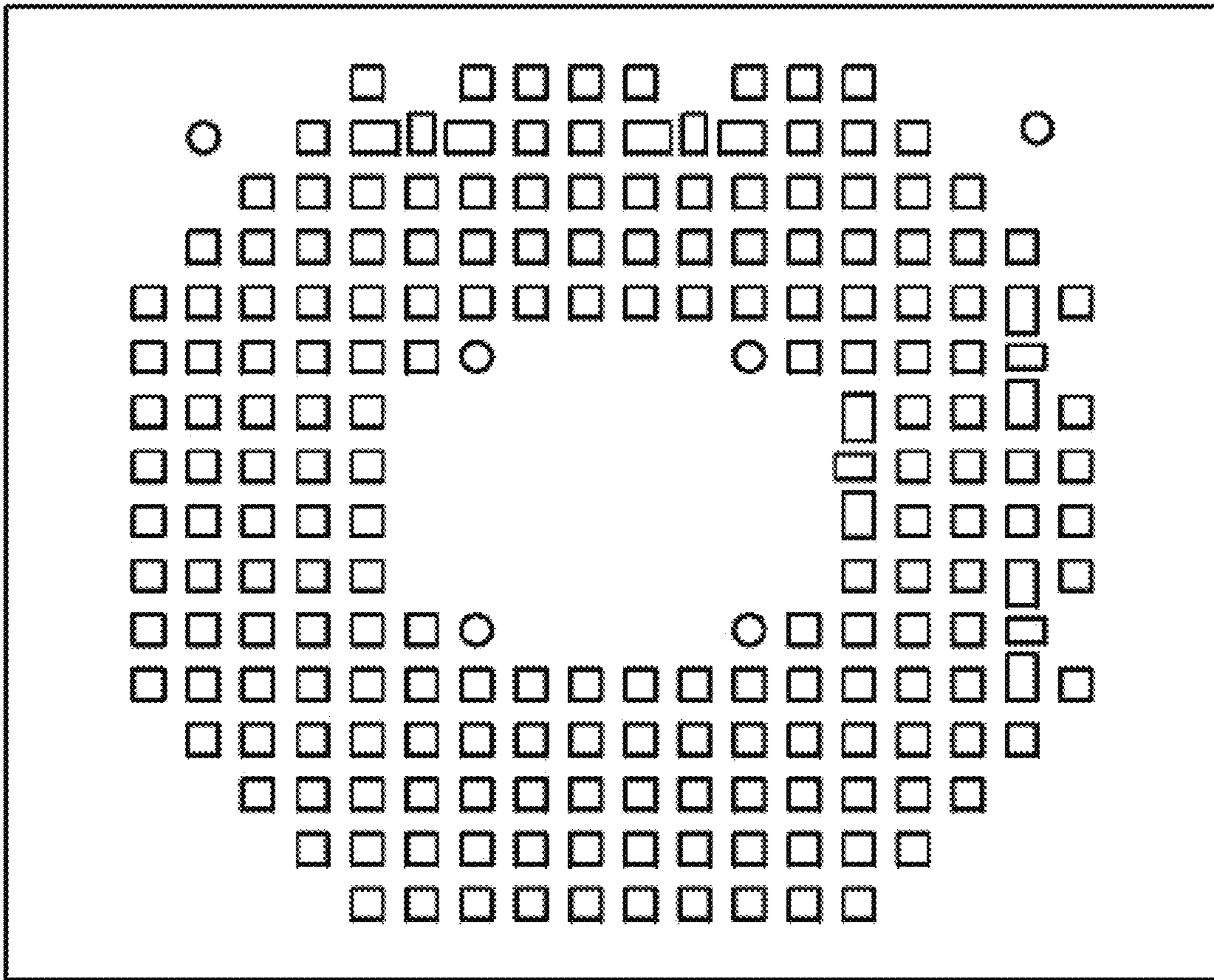

*Fig. 1*

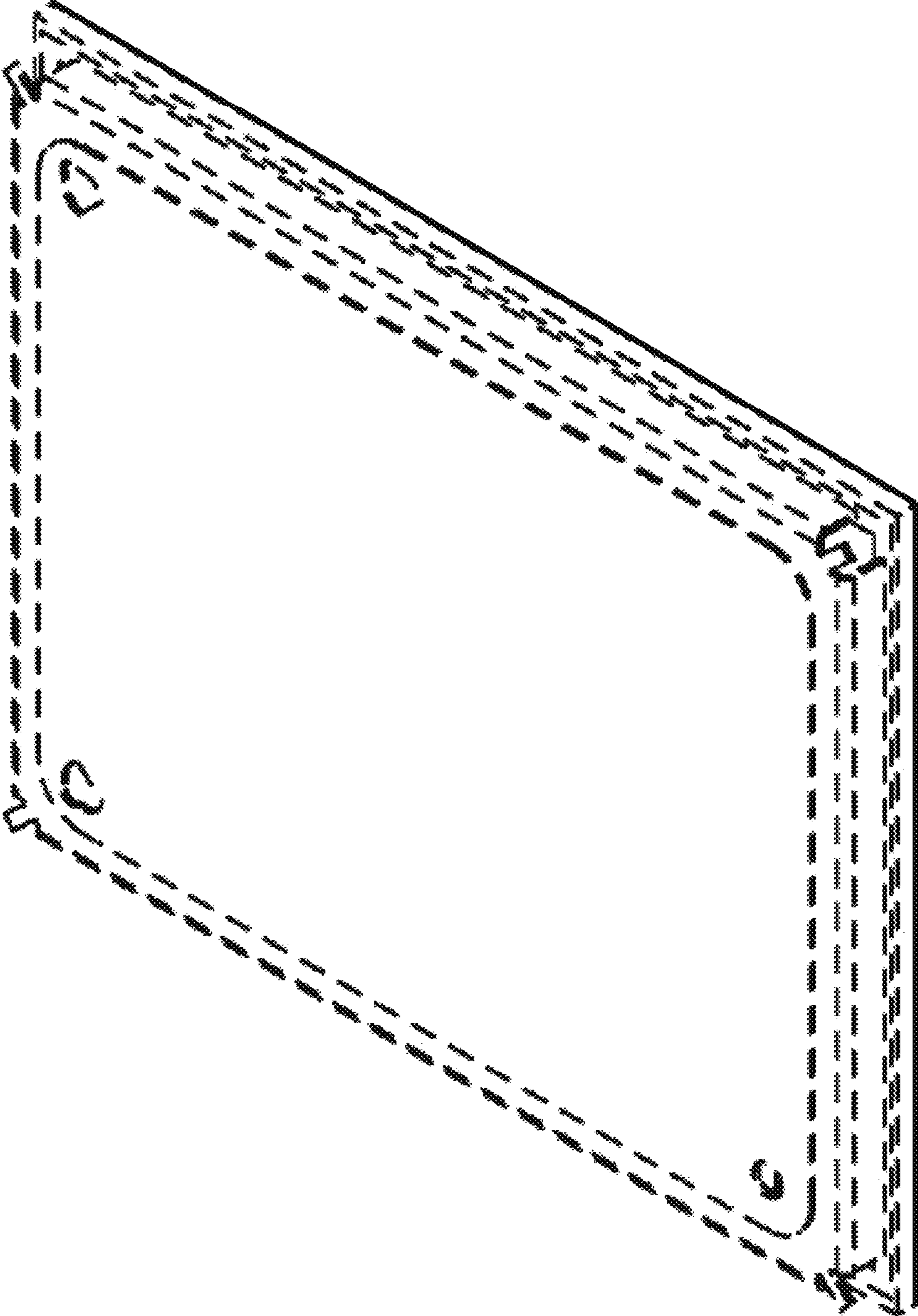

*Fig. 2*

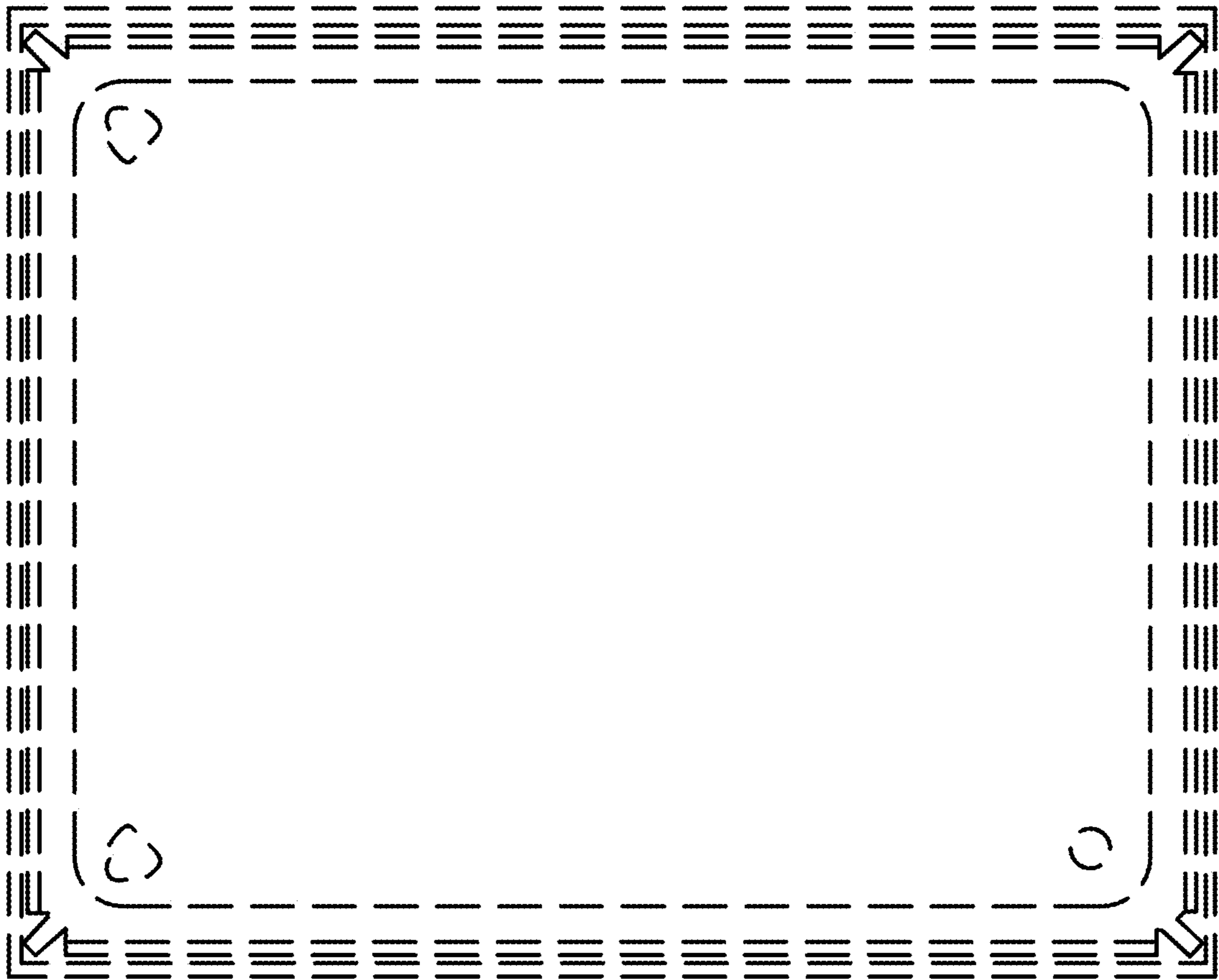

*Fig. 3*

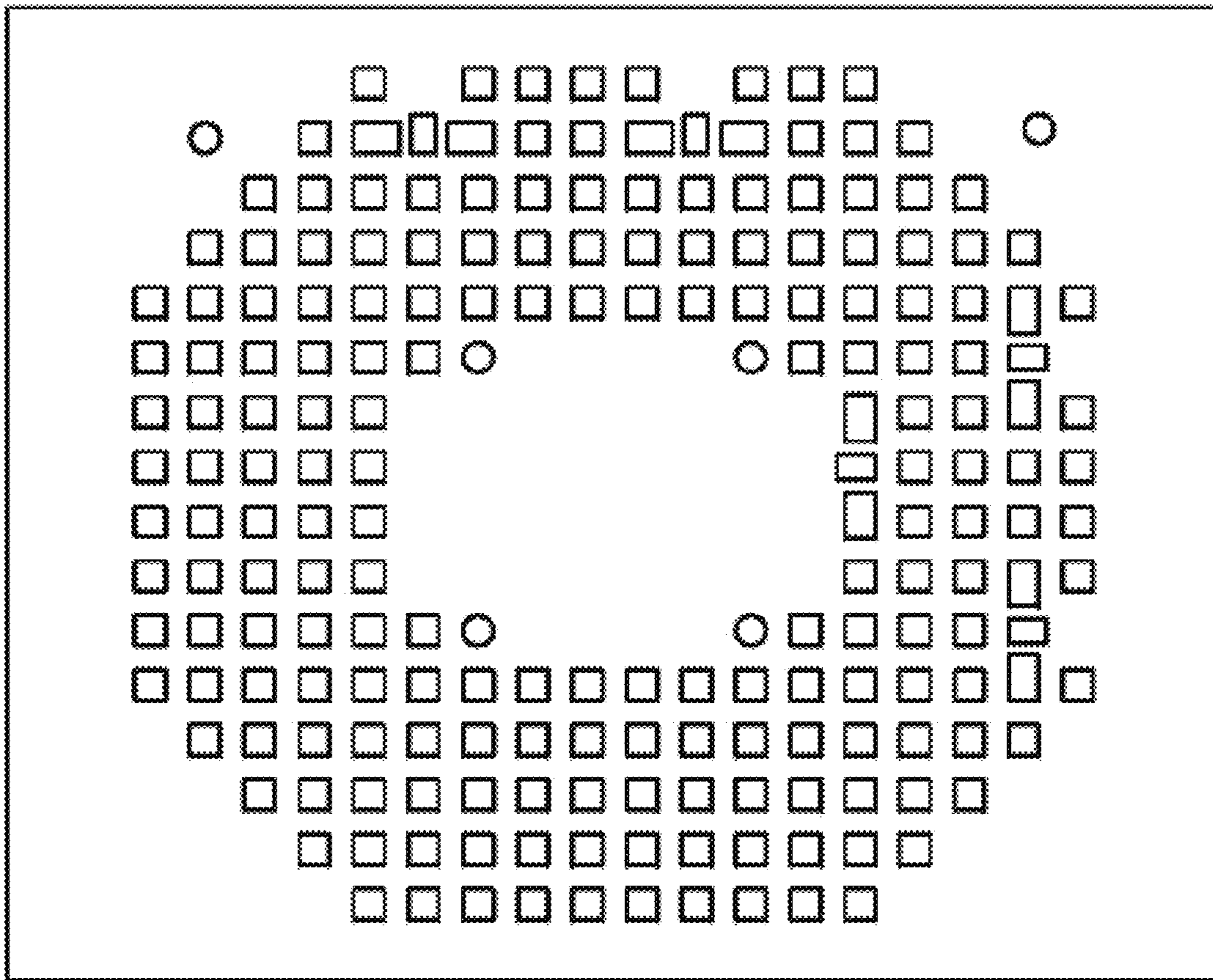

*Fig. 4*

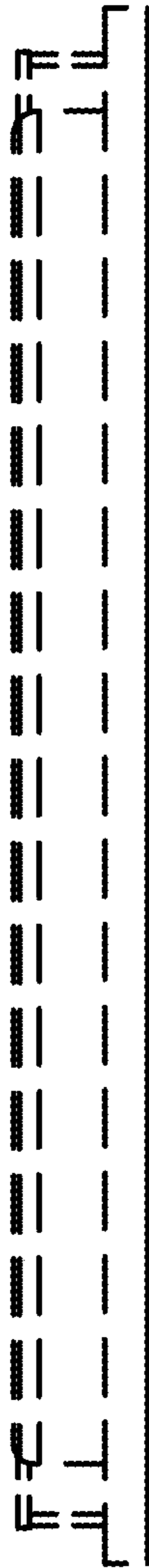
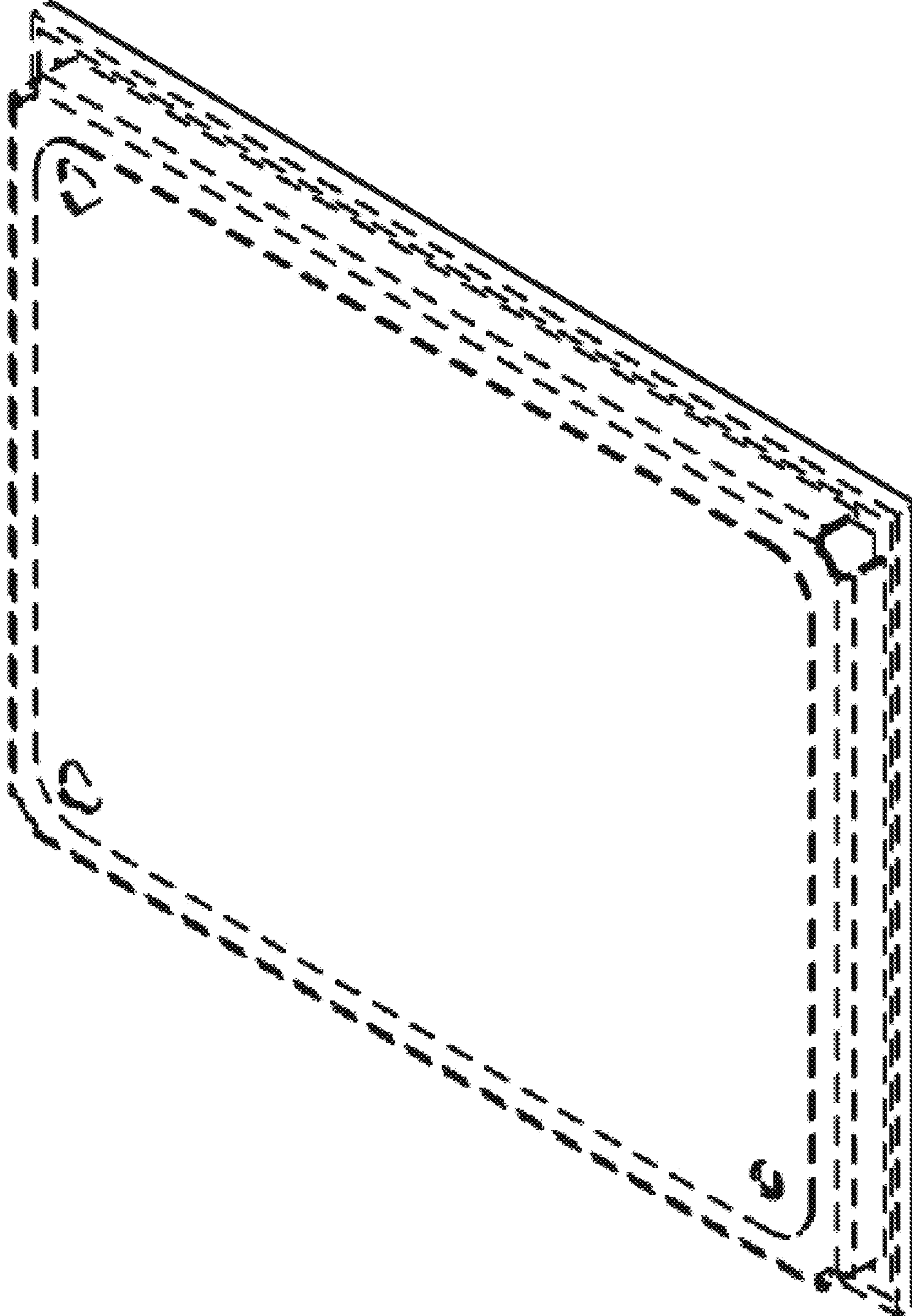

*Fig. 5*

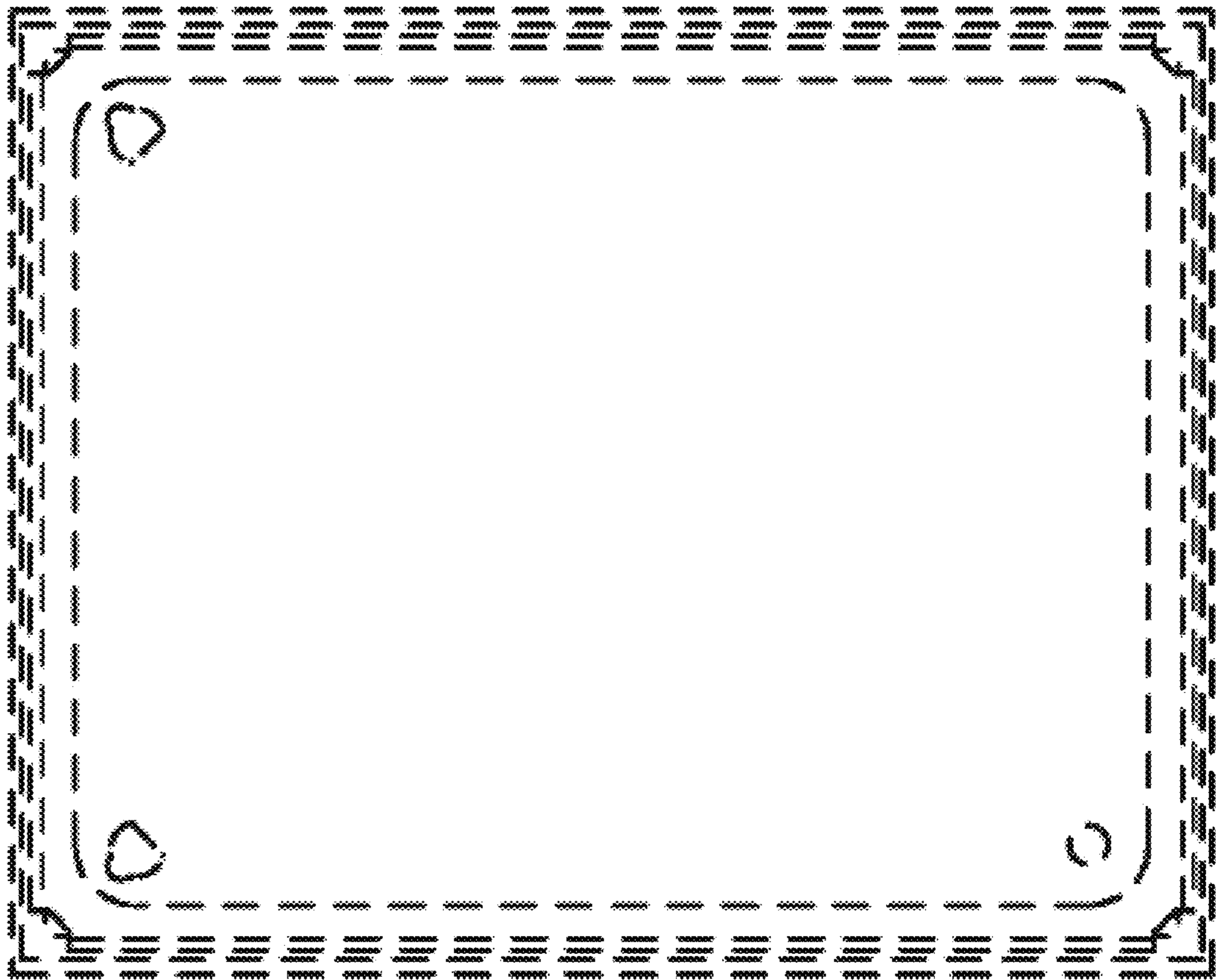

*Fig. 6*

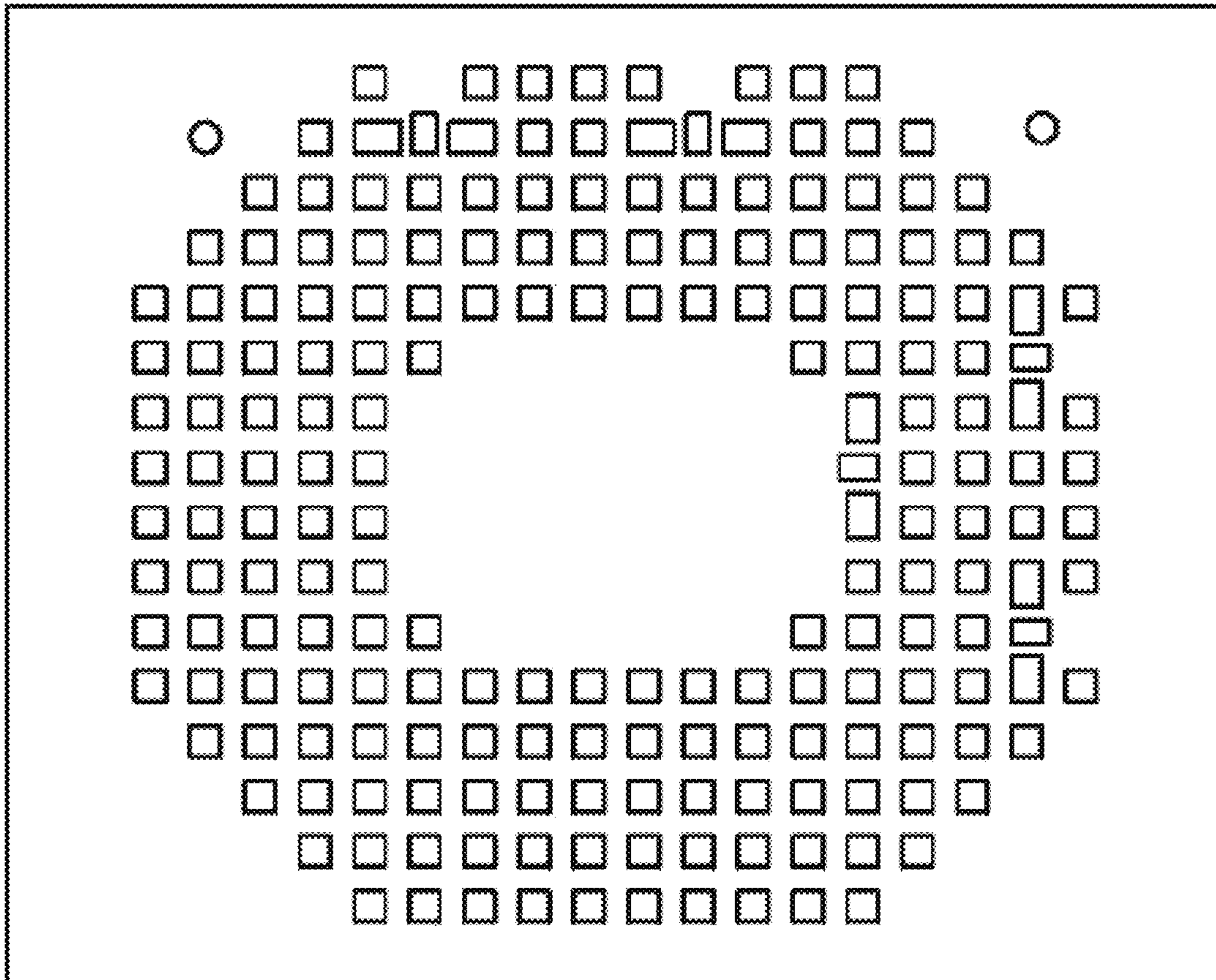



*Fig. 7*



*Fig. 8*



*Fig. 9*

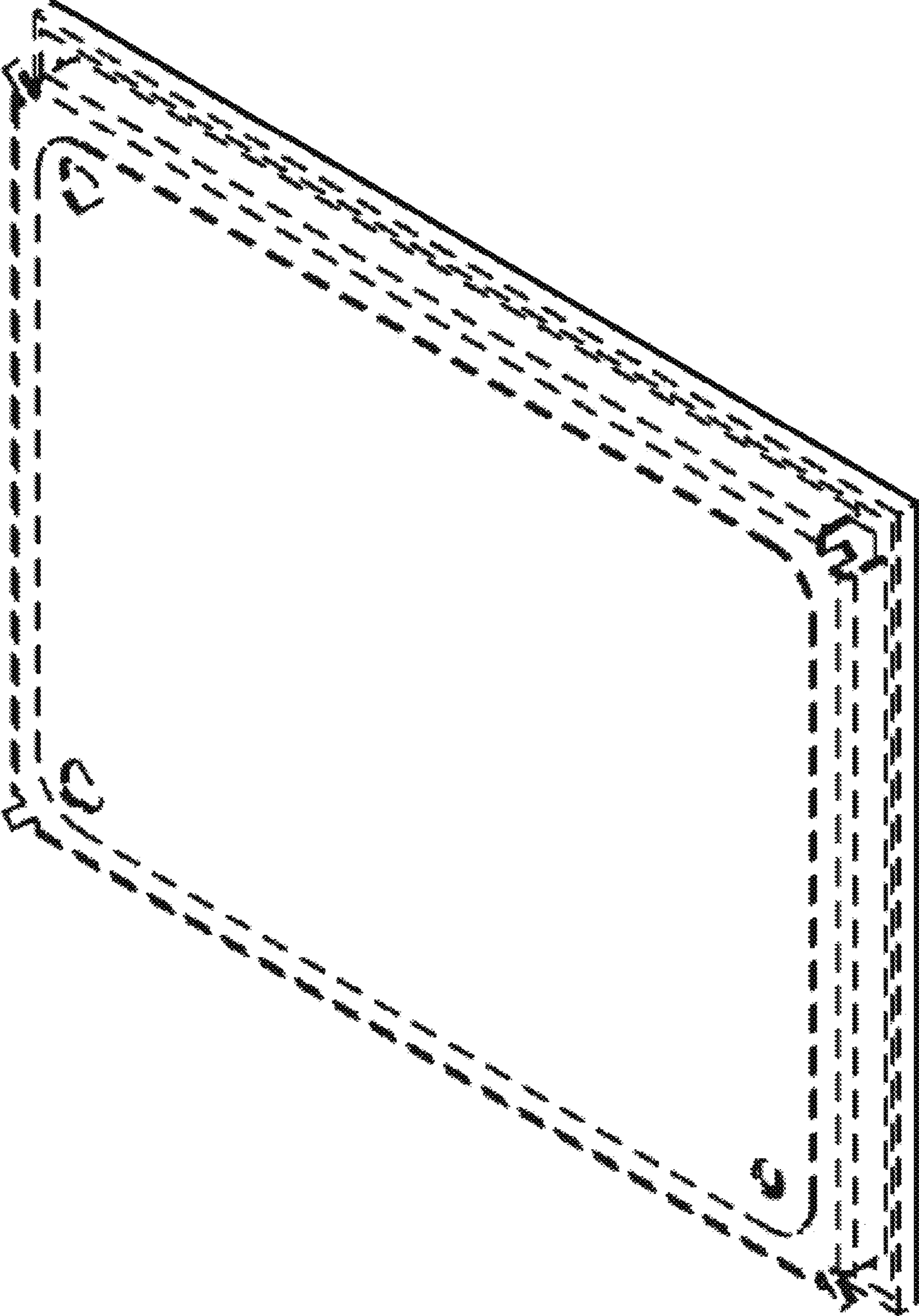

*Fig. 10*

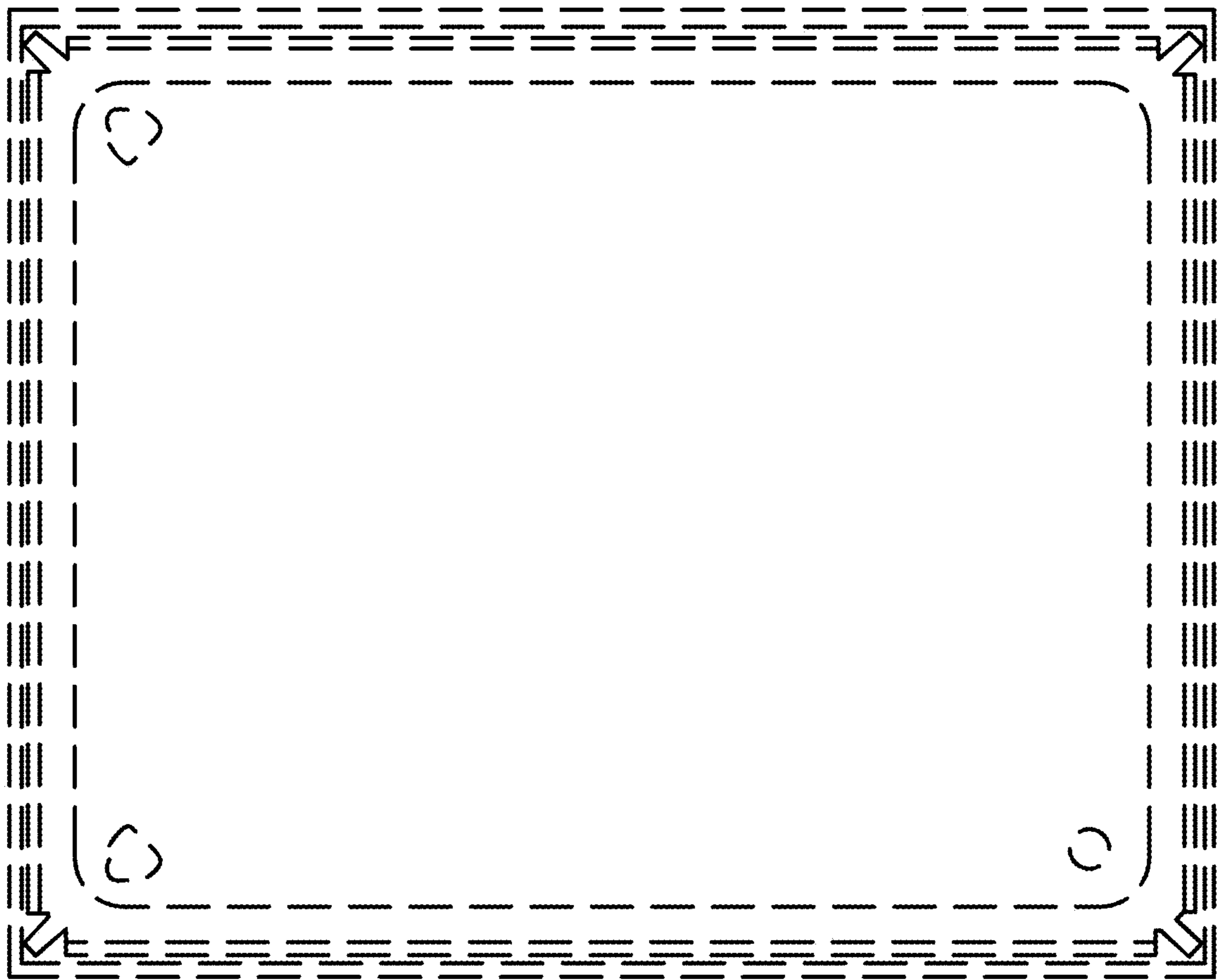

*Fig. 11*

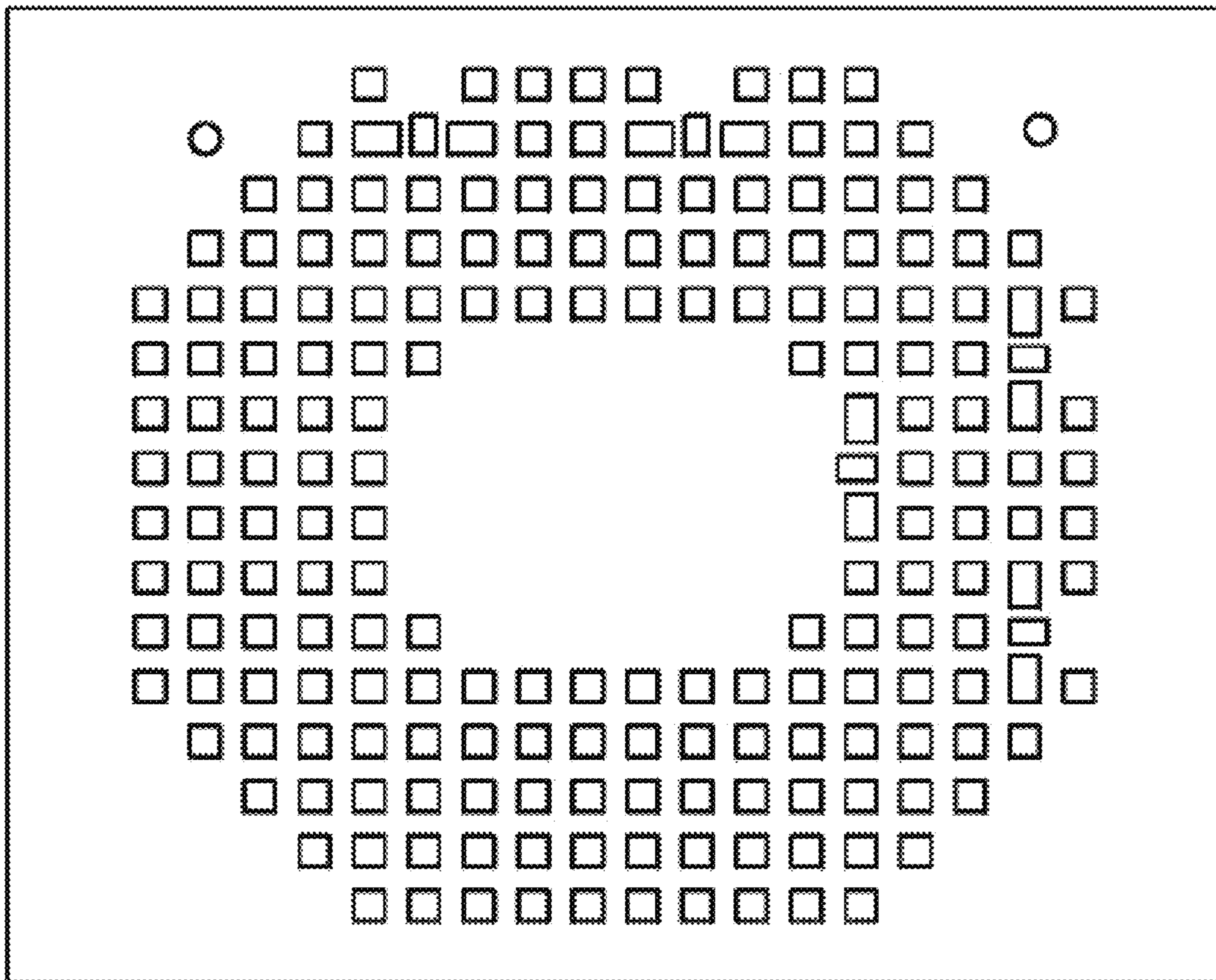

*Fig. 12*

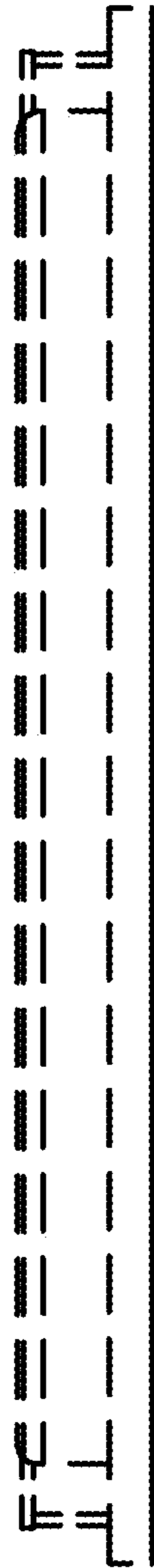
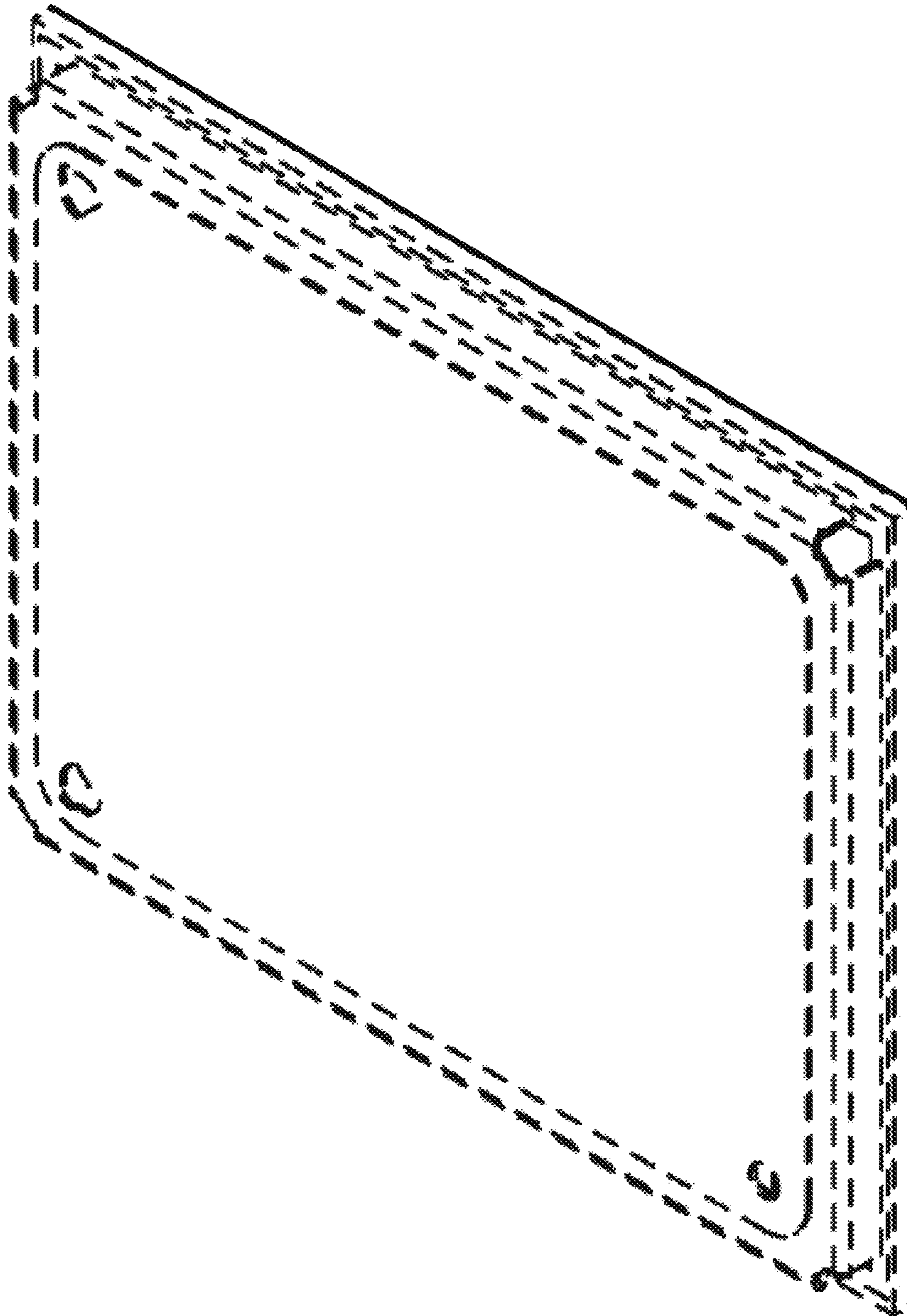

*Fig. 13*

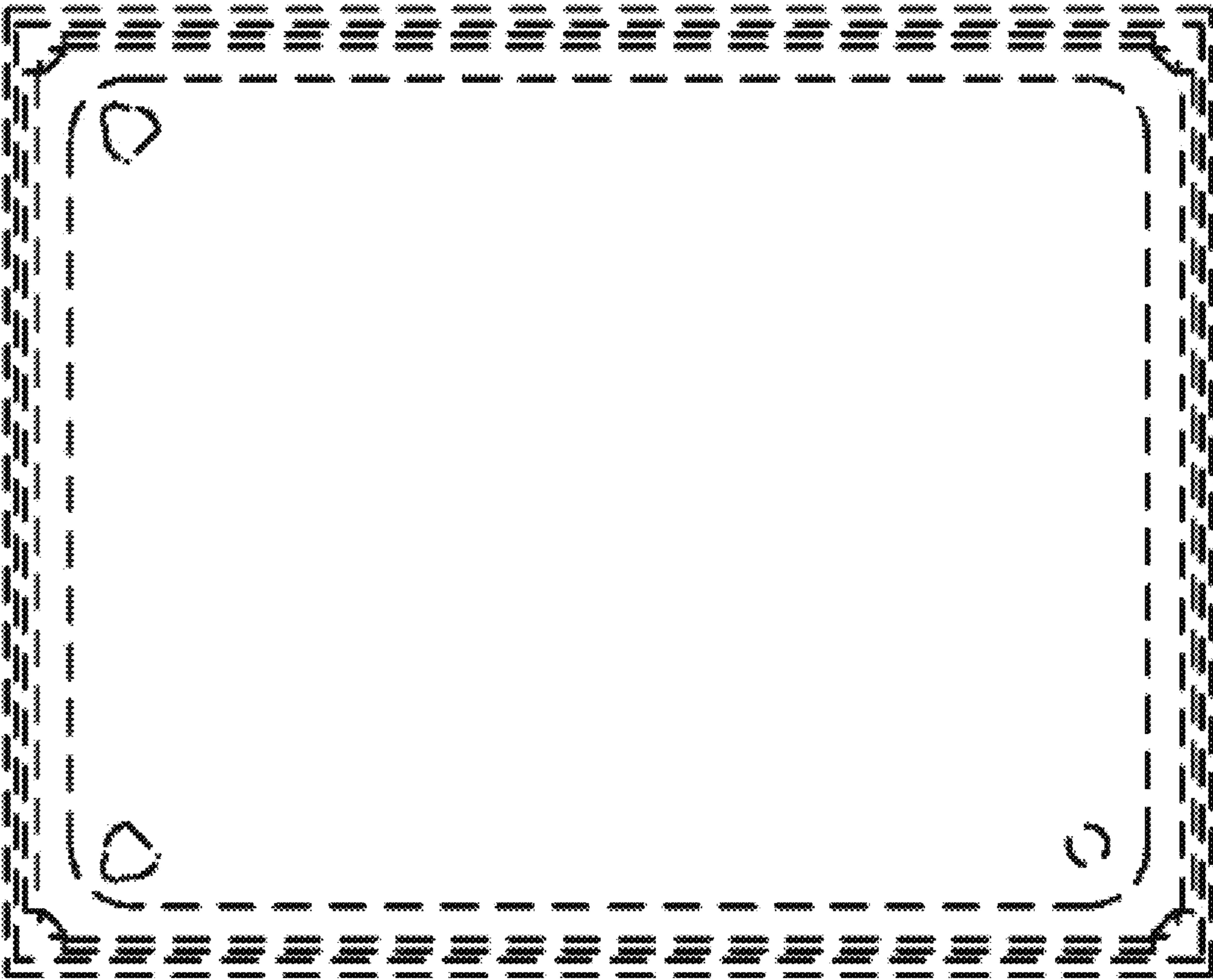

*Fig. 14*

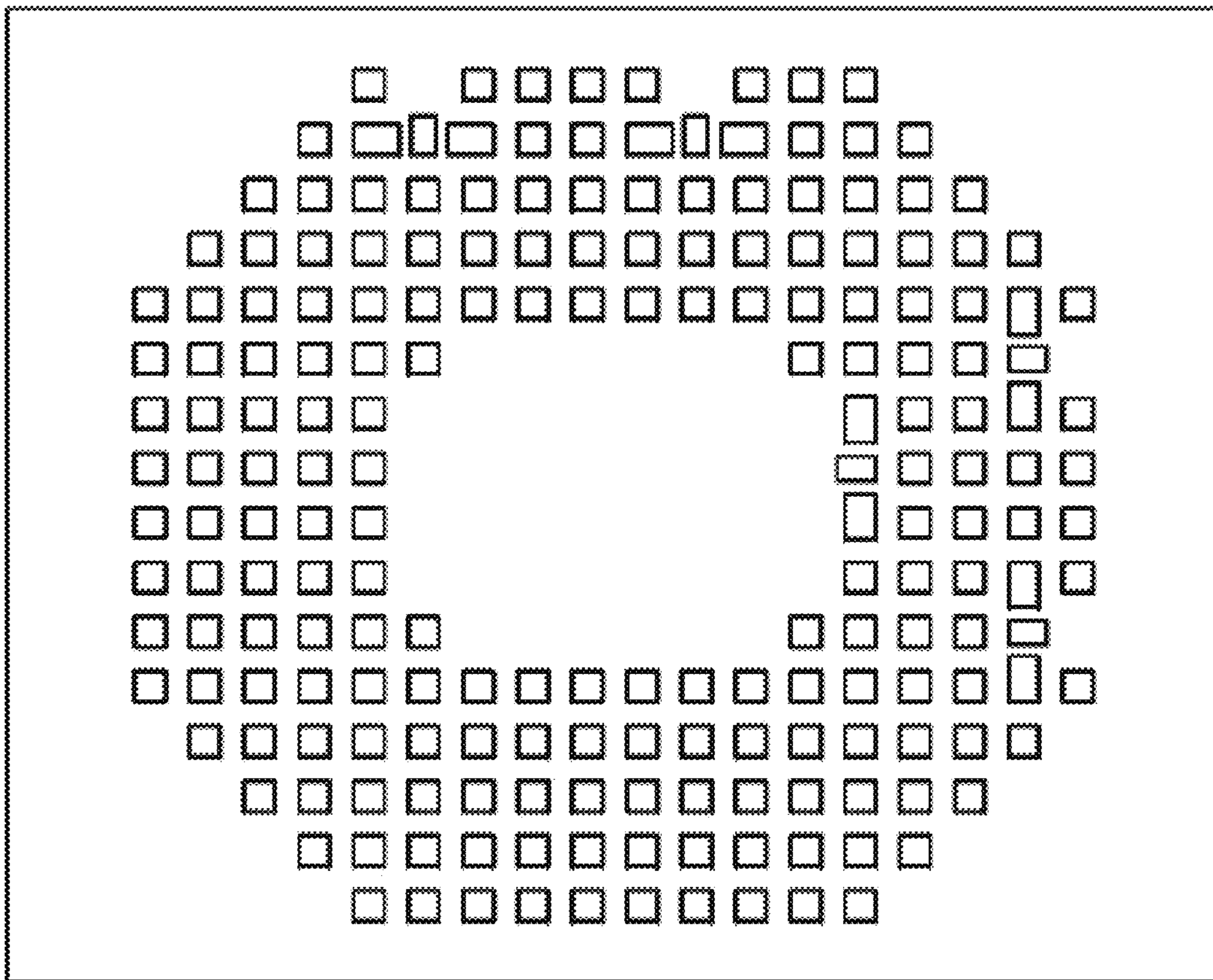



*Fig. 15*



*Fig. 16*



*Fig. 17*

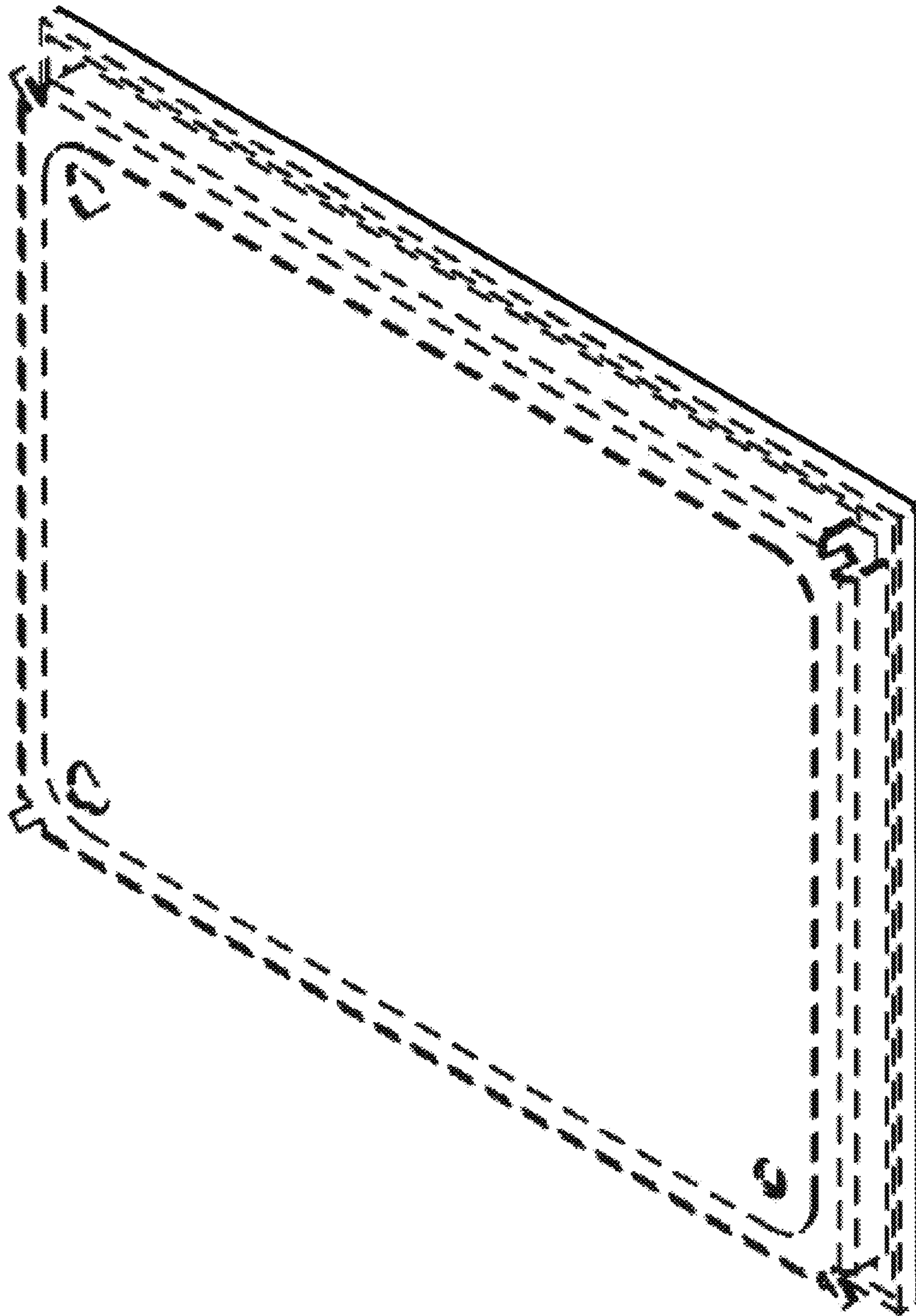

*Fig. 18*

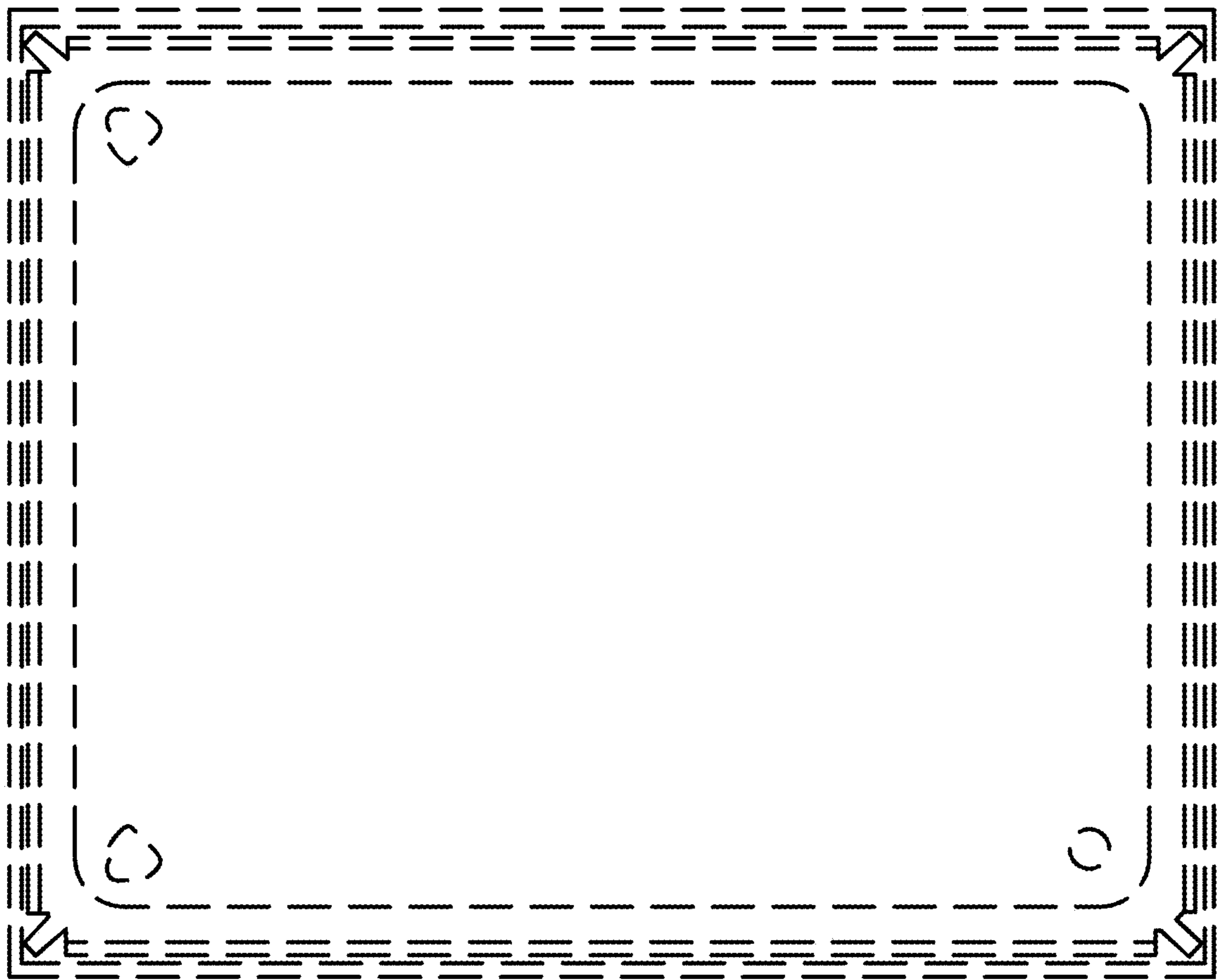

*Fig. 19*

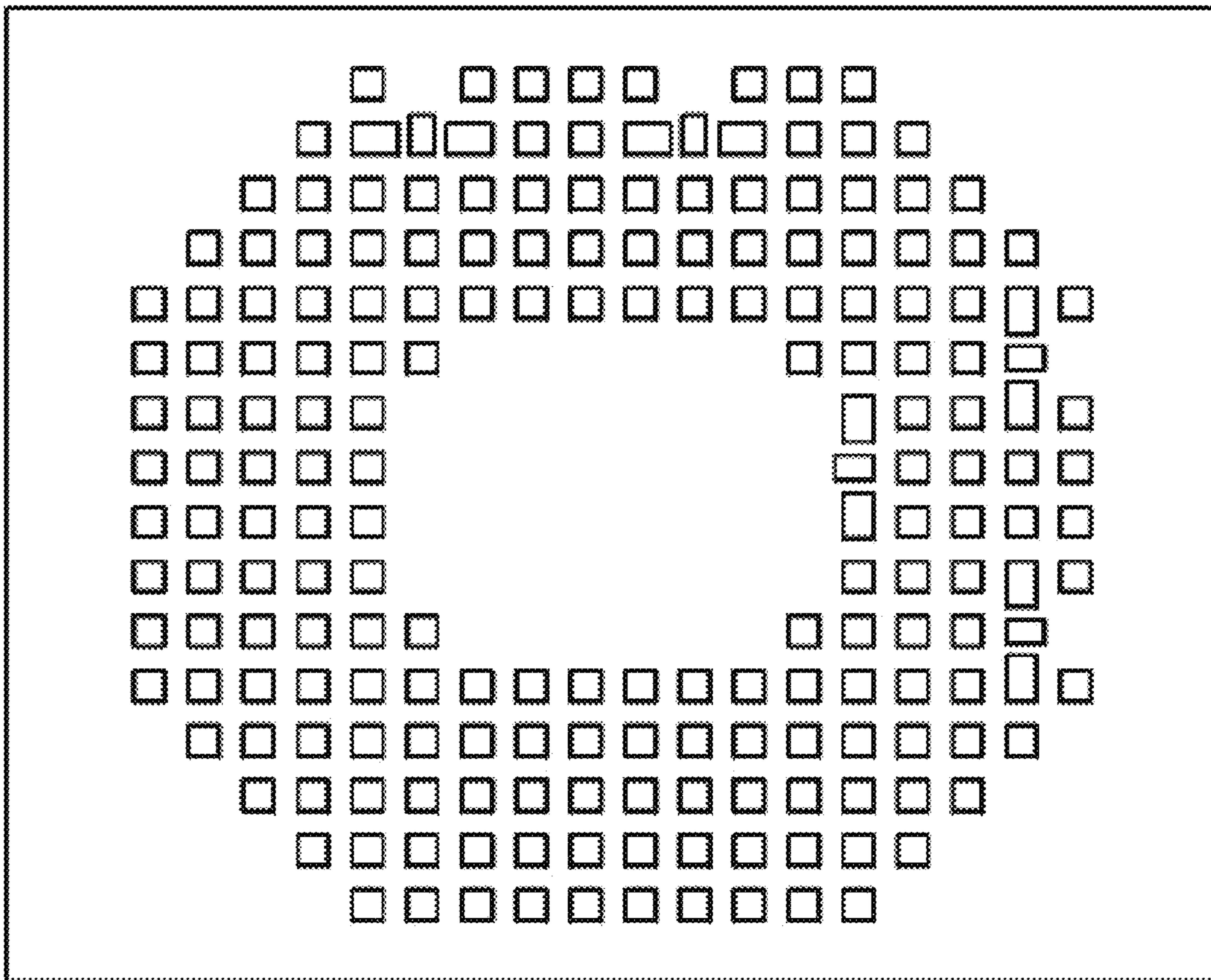

*Fig. 20*

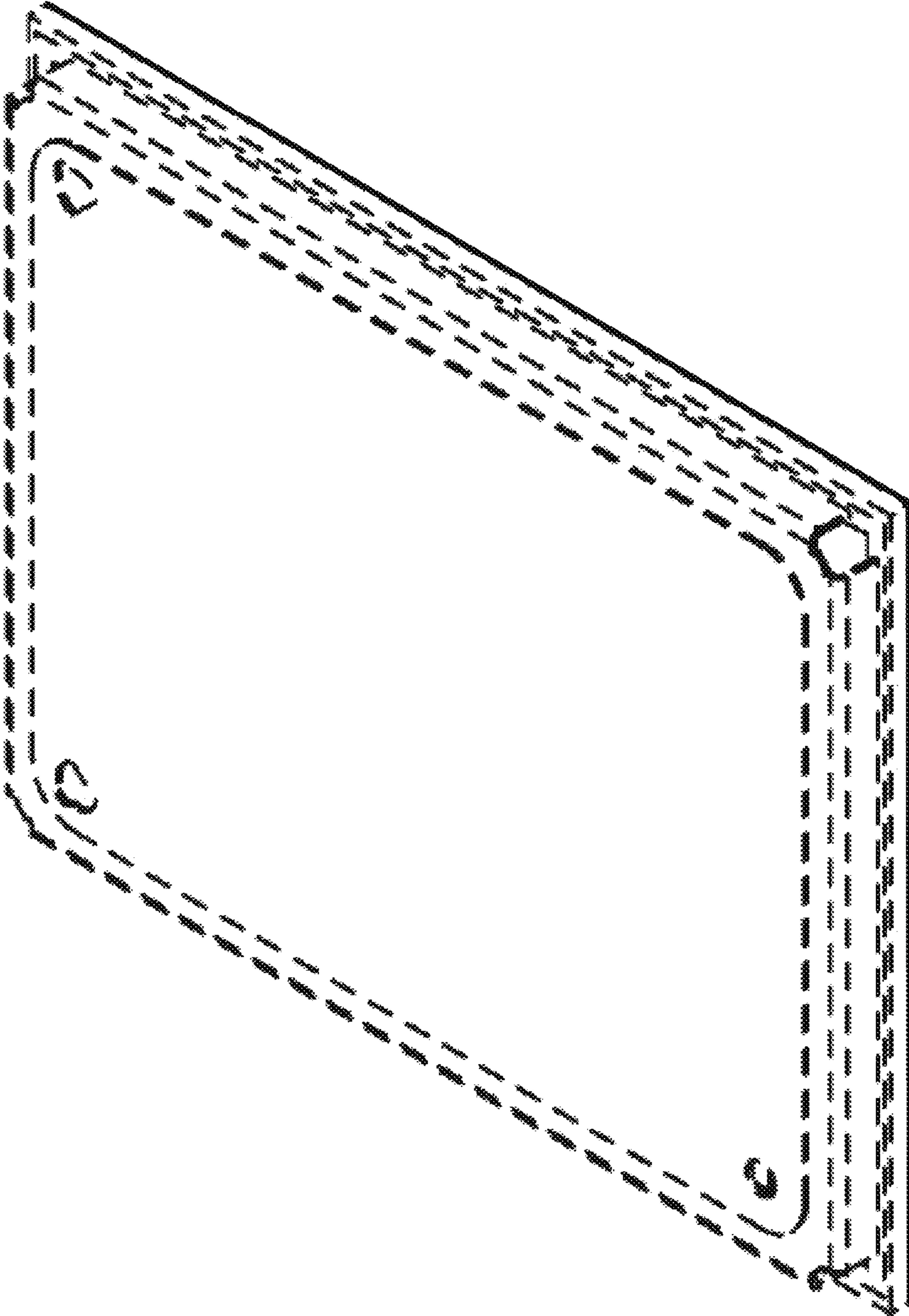

*Fig. 21*

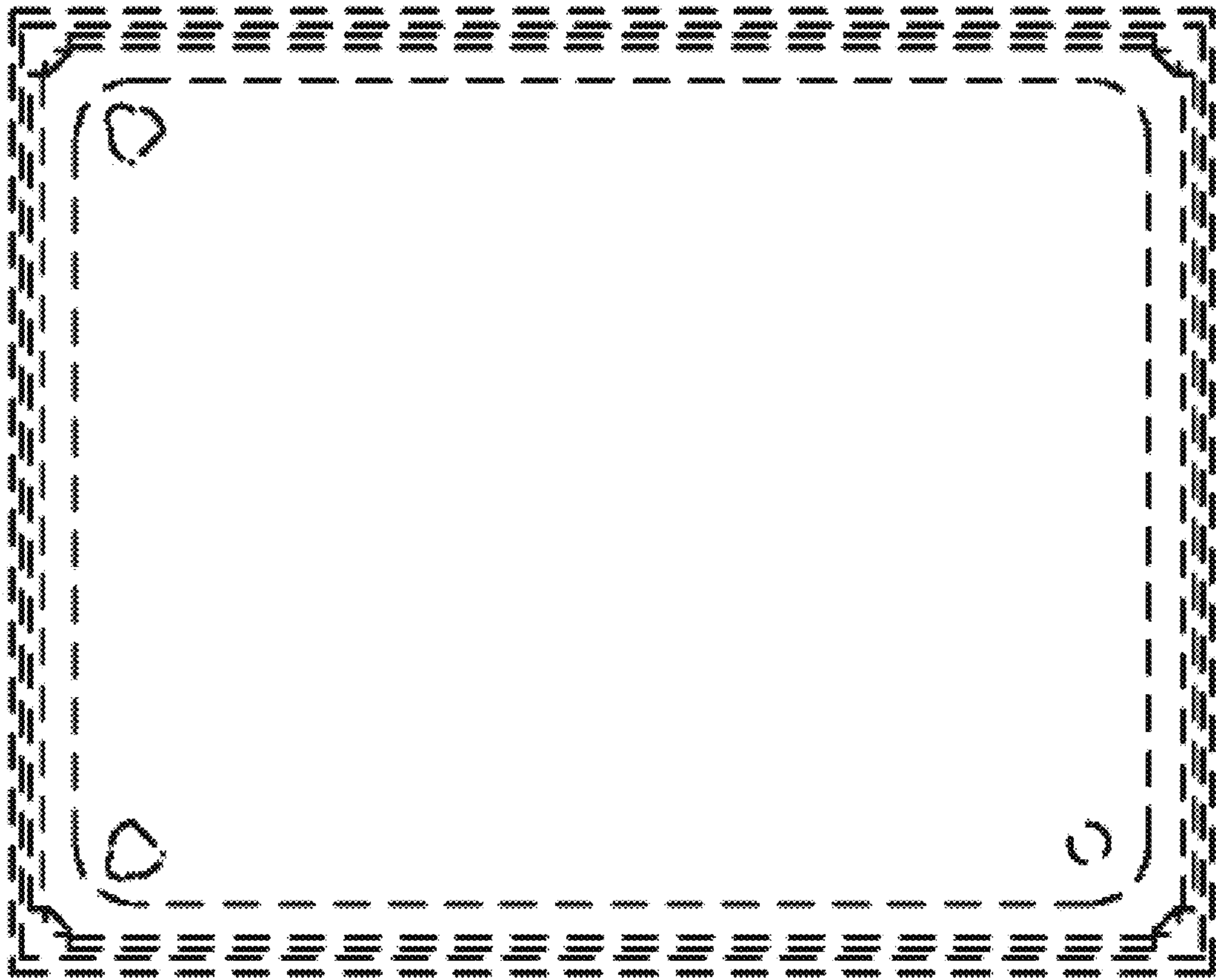

*Fig. 22*





*Fig. 23*



*Fig. 24*