



US00D904257S

(12) **United States Design Patent** (10) **Patent No.:** **US D904,257 S**  
**DiCanzio** (45) **Date of Patent:** **\*\* Dec. 8, 2020**

(54) **AUTOMOBILE REAR MUD FLAP**

D328,447 S \* 8/1992 Ahleen ..... D12/185

D332,770 S \* 1/1993 Rutter ..... D12/185

5,407,229 A \* 4/1995 Garrett ..... B62D 25/18  
280/851

(71) Applicant: **Turn 5, Inc.**, Paoli, PA (US)

D406,087 S \* 2/1999 Bavington ..... D12/185

D415,460 S \* 10/1999 Ward ..... D12/185

(72) Inventor: **Michael DiCanzio**, West Chester, PA (US)

(Continued)

(73) Assignee: **Turn 5, Inc.**, Paoli, PA (US)

*Primary Examiner* — Darlington Ly

(\*\*) Term: **15 Years**

(74) *Attorney, Agent, or Firm* — Schott PC.

(21) Appl. No.: **29/688,816**

(57) **CLAIM**

(22) Filed: **Apr. 24, 2019**

The ornamental design for an automobile rear mud flap, as shown and described.

**Related U.S. Application Data**

**DESCRIPTION**

(63) Continuation of application No. 29/602,007, filed on Apr. 27, 2017, now abandoned.

FIG. 1 is a perspective view of a driver side automobile rear mud flap showing my new design in accordance to a first embodiment;

(51) **LOC (12) Cl.** ..... **12-16**

FIG. 2 is a front elevation view thereof;

(52) **U.S. Cl.**

FIG. 3 is a rear elevation view thereof;

USPC ..... **D12/185**

FIG. 4 is a top plan view thereof;

(58) **Field of Classification Search**

USPC ..... D12/90–92, 93, 96, 181, 184, 185, 196, D12/202

FIG. 5 is a bottom plan view thereof;

CPC ..... B62D 25/18; B62D 25/188

FIG. 6 is a right side elevation view thereof;

See application file for complete search history.

FIG. 7 is a left side elevation view thereof;

(56) **References Cited**

FIG. 8 is a perspective view thereof in a potential environment;

**U.S. PATENT DOCUMENTS**

FIG. 9 is a perspective view of a passenger side automobile rear mud flap showing my new design in accordance to a second embodiment;

D241,827 S \* 10/1976 Podall ..... D12/185

FIG. 10 is a front elevation view thereof;

D260,759 S \* 9/1981 Arenhold ..... D12/185

FIG. 11 is a rear elevation view thereof;

4,315,634 A \* 2/1982 Arenhold ..... B62D 25/18  
280/851

FIG. 12 is a top plan view thereof;

D274,324 S \* 6/1984 Arenhold ..... D12/185

FIG. 13 is a bottom plan view thereof;

D279,560 S \* 7/1985 Jensen ..... D12/185

FIG. 14 is a right side elevation view thereof; and,

D281,966 S \* 12/1985 Lockwood ..... D12/185

FIG. 15 is a left side elevation view thereof.

D282,158 S \* 1/1986 Wright ..... D12/185

The broken lines showing portions of the automobile rear mud flap and environmental structure of an automobile form no part of the claimed design.

D301,710 S \* 6/1989 Ward ..... D12/185

**1 Claim, 15 Drawing Sheets**

D308,847 S \* 6/1990 Price ..... D12/185

D308,958 S \* 7/1990 Knox ..... D12/185

D309,724 S \* 8/1990 Jurgens ..... D12/185

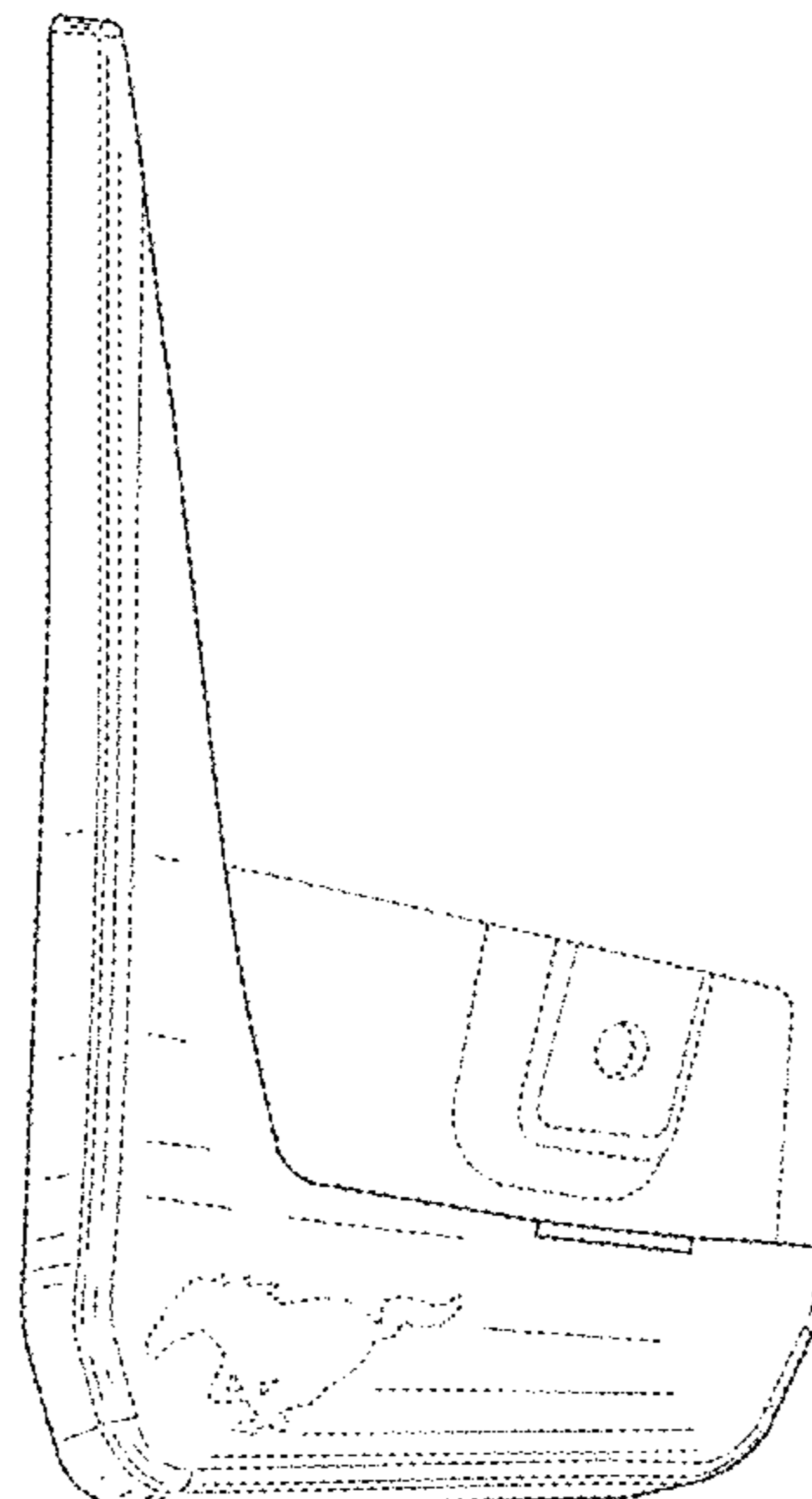

(56)

**References Cited**

U.S. PATENT DOCUMENTS

6,179,311 B1 *	1/2001	Larkin	.....	B62D 25/188
				280/154
D615,468 S *	5/2010	Harris	.....	D12/185
9,004,538 B2 *	4/2015	Eklund	.....	B62D 25/18
				280/851
D792,823 S *	7/2017	Senatro	.....	D12/185
9,724,974 B2 *	8/2017	Schmeichel	.....	B62D 25/188

\* cited by examiner

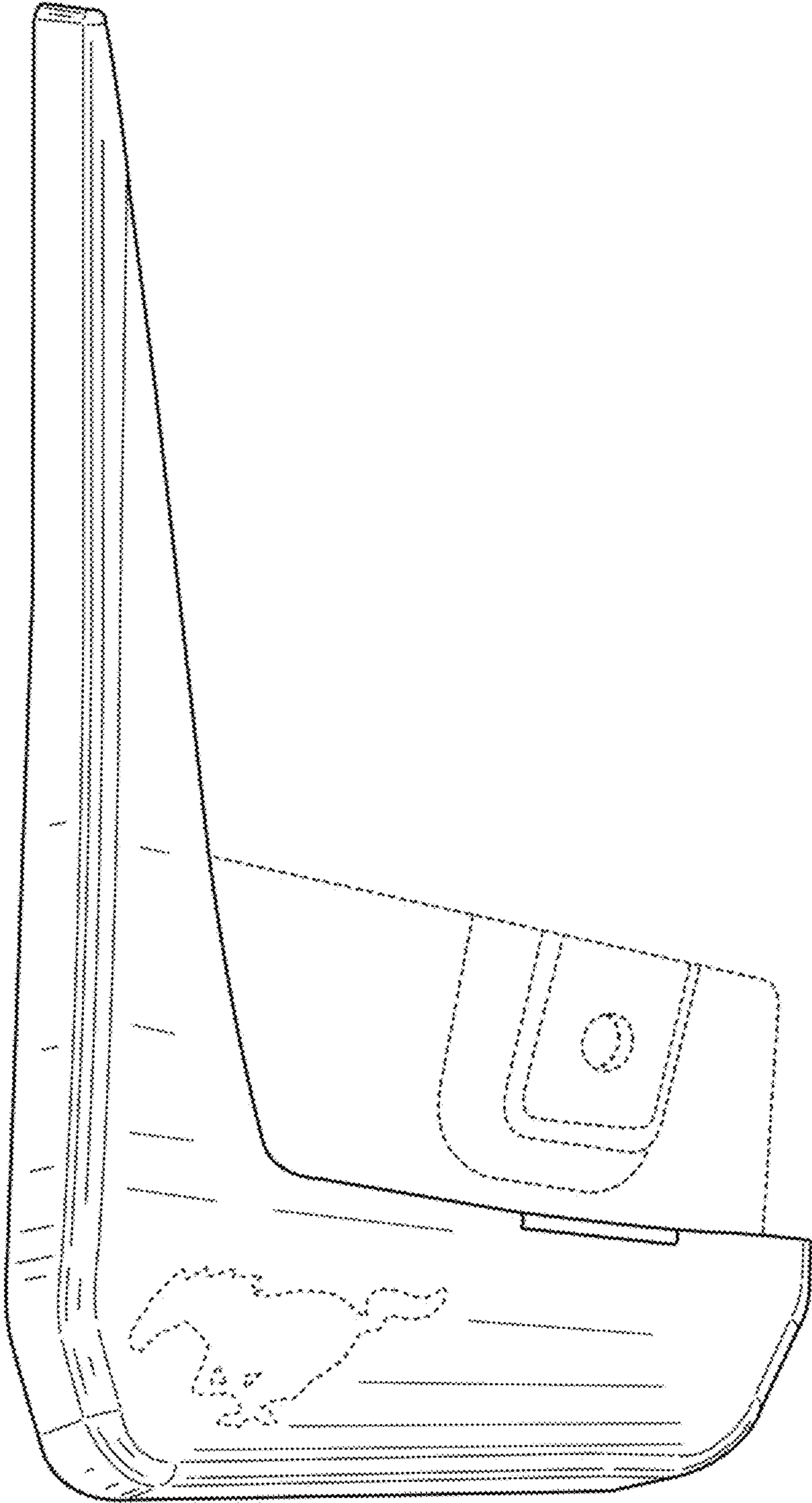

FIG. 1

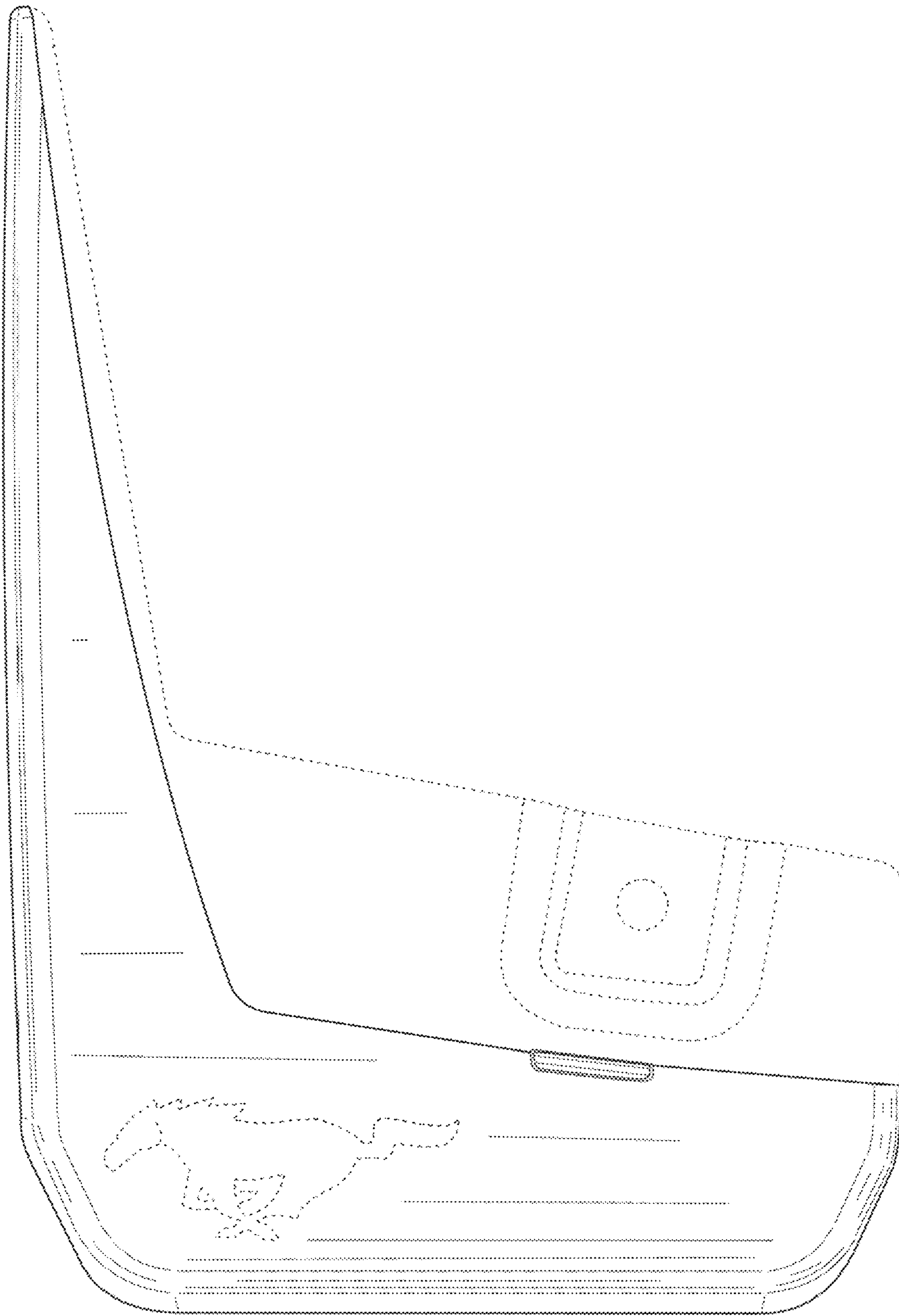

FIG. 2

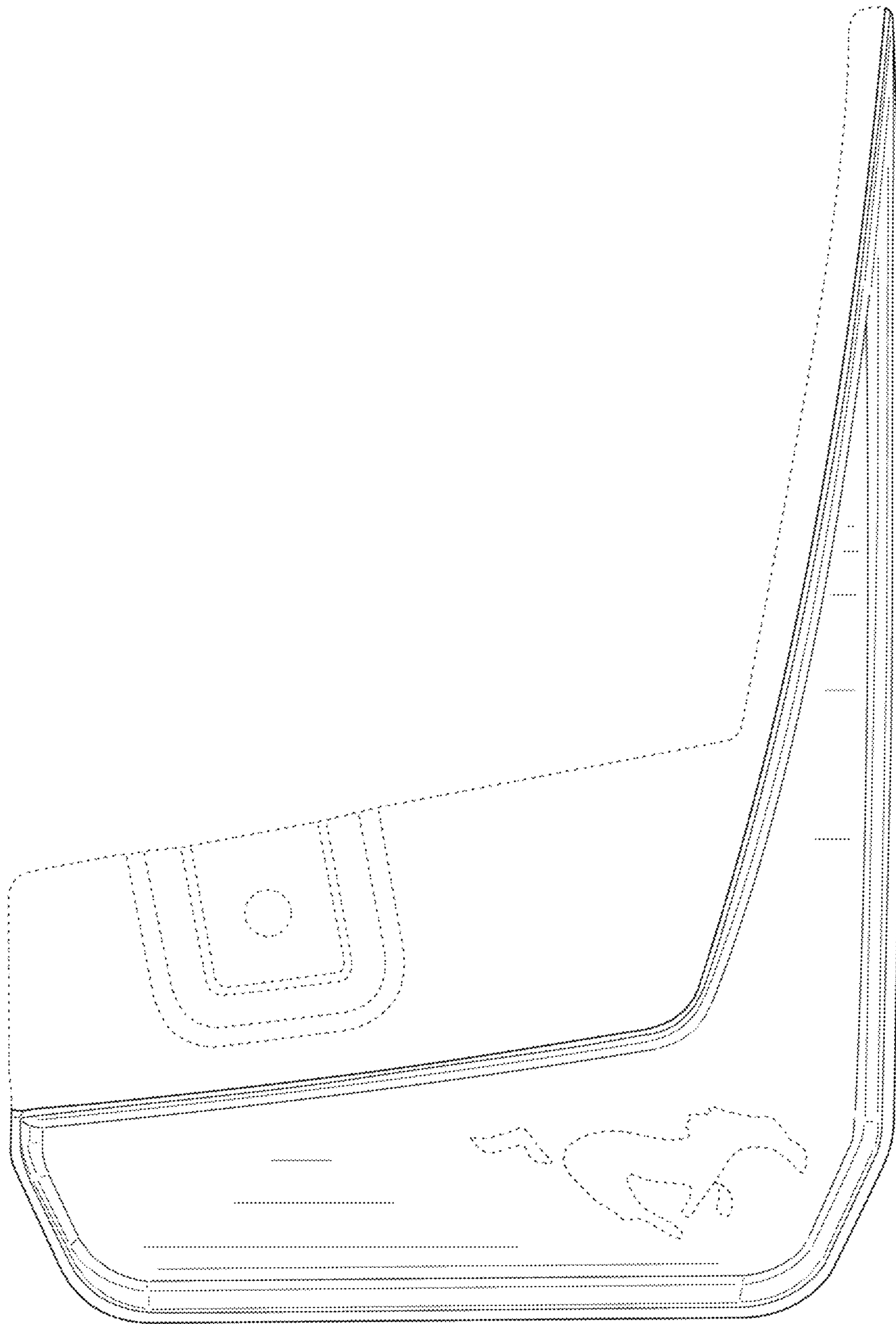

FIG. 3

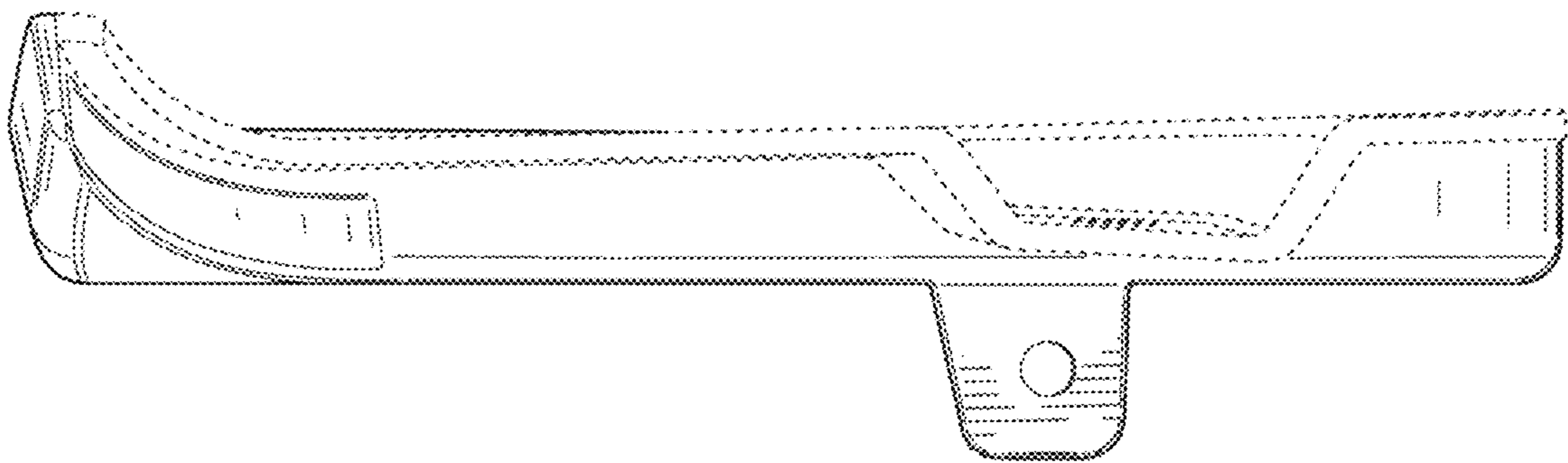

FIG. 4

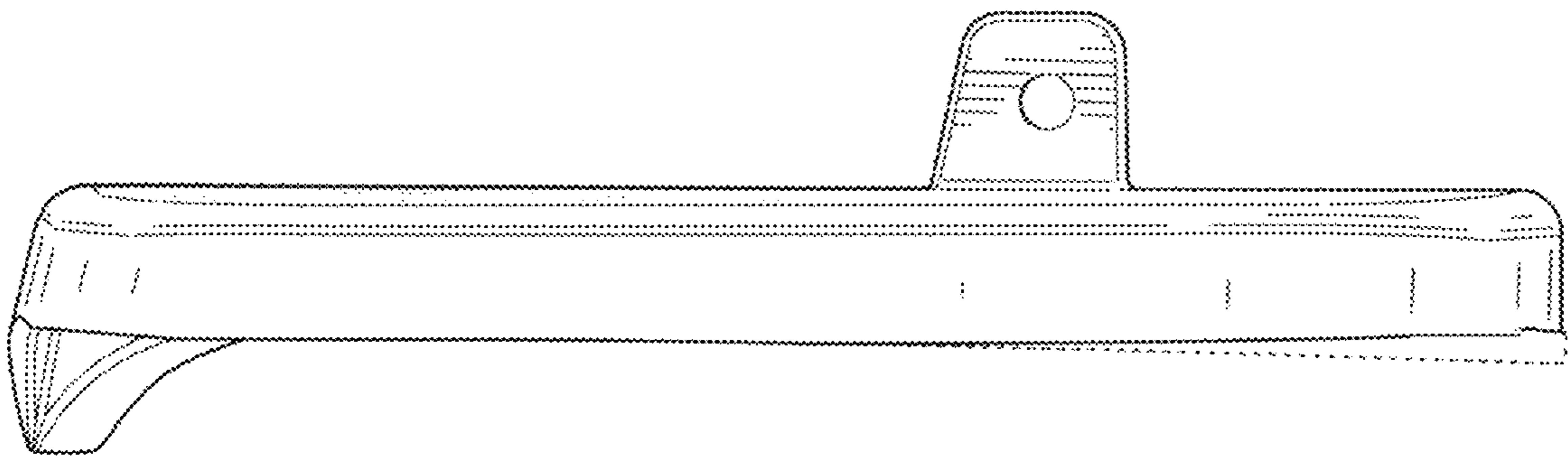

FIG. 5

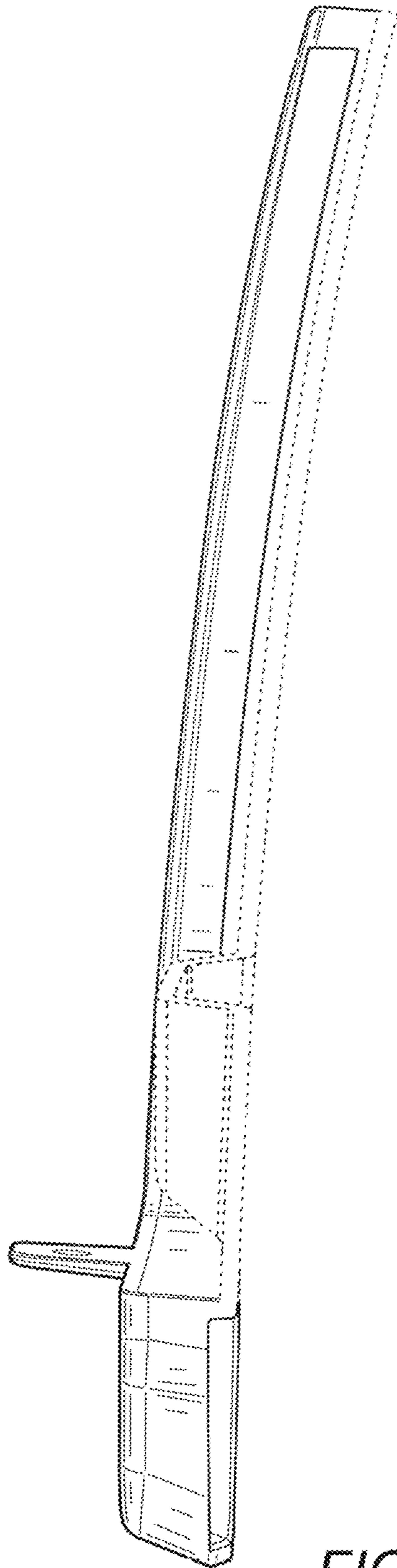

FIG. 6



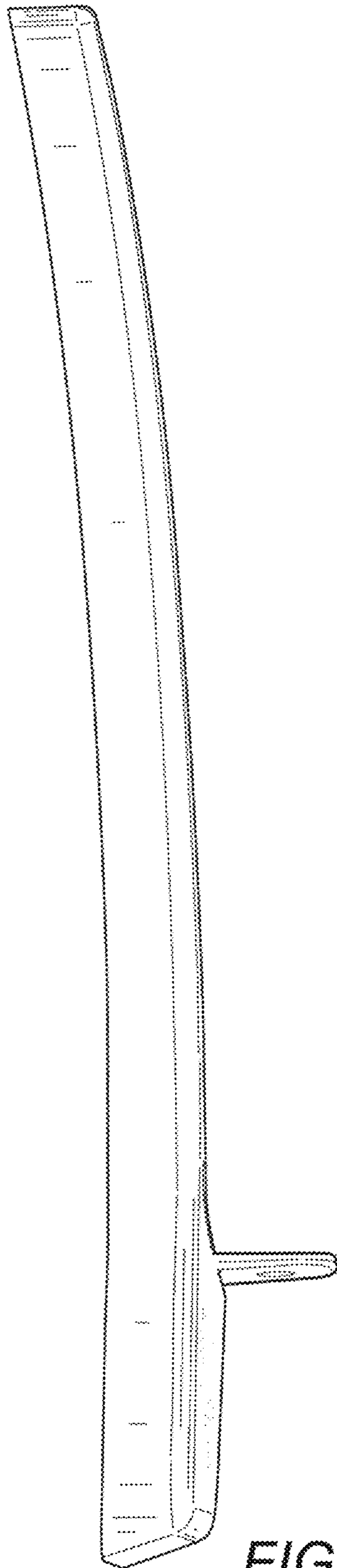

FIG. 7

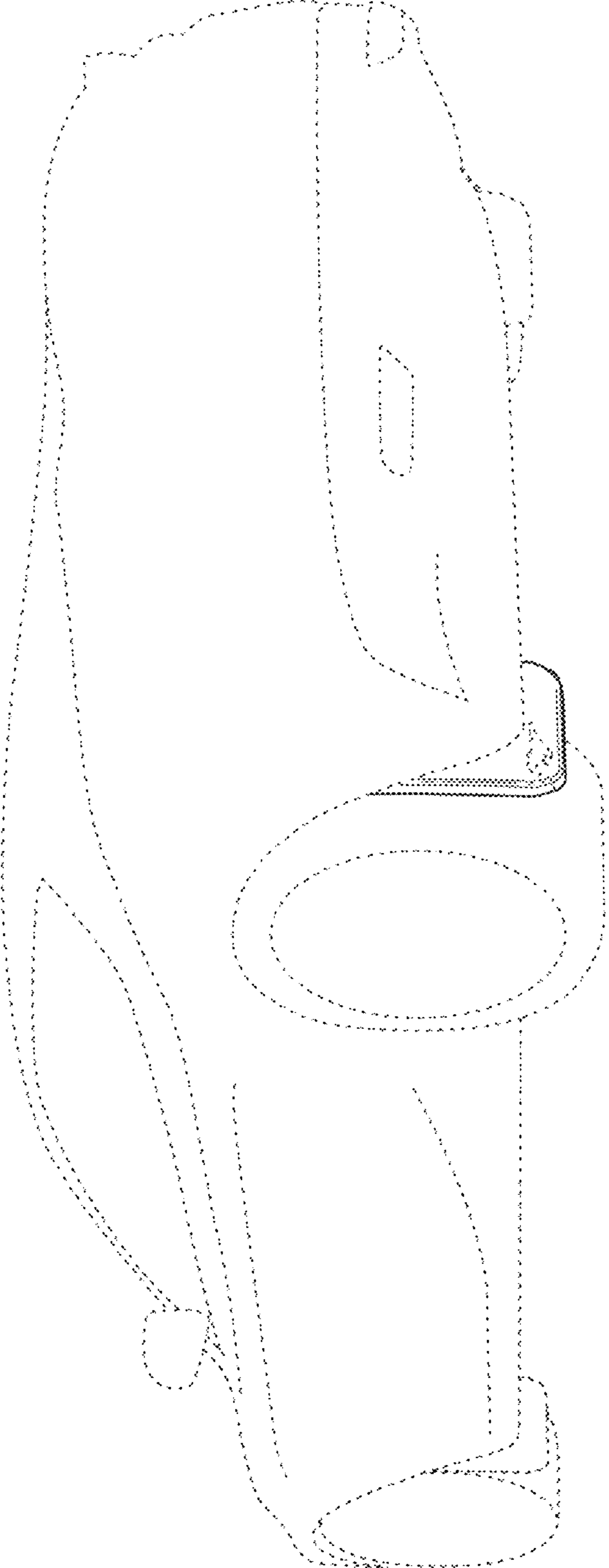

FIG. 8

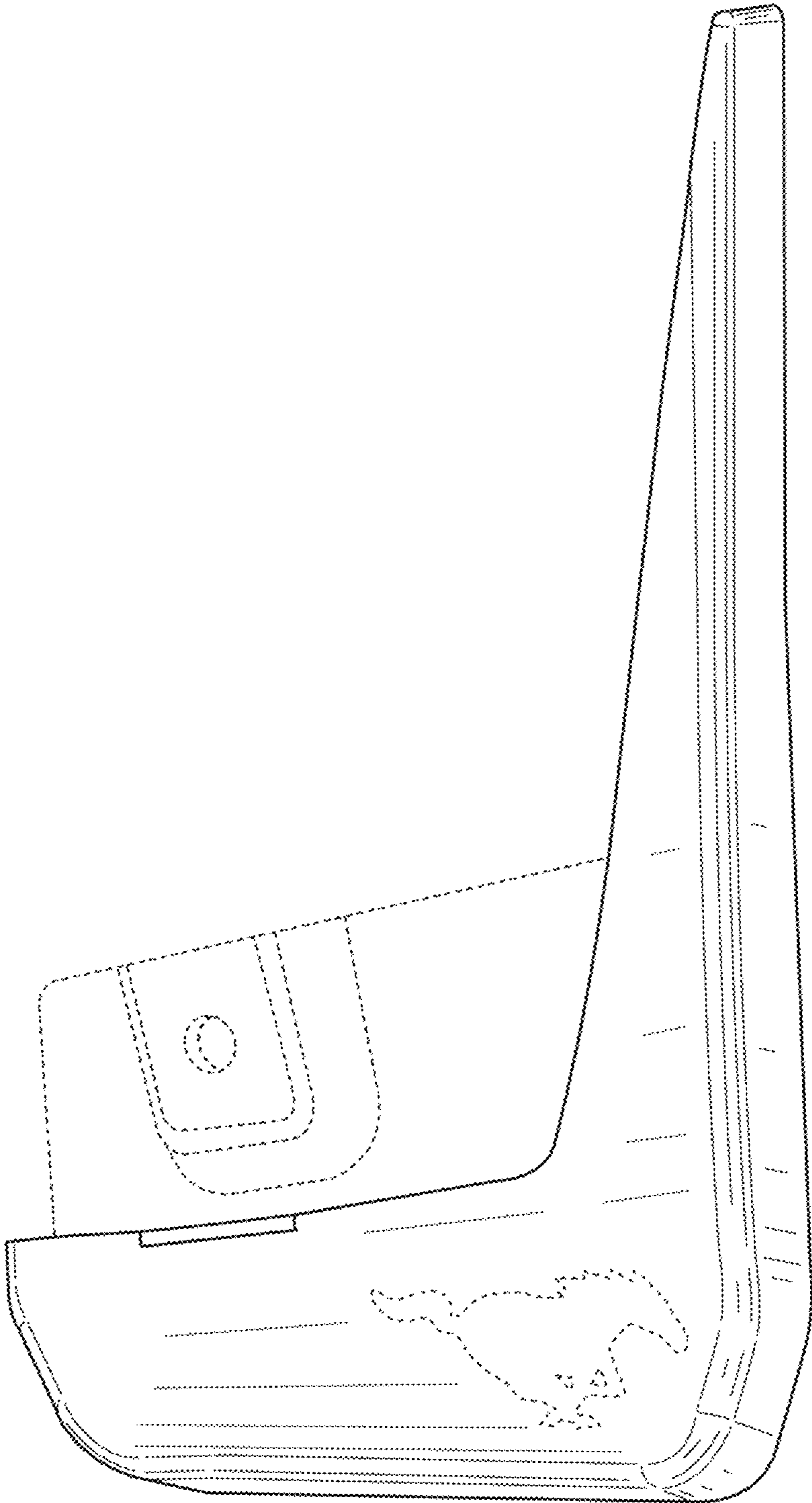

FIG. 9

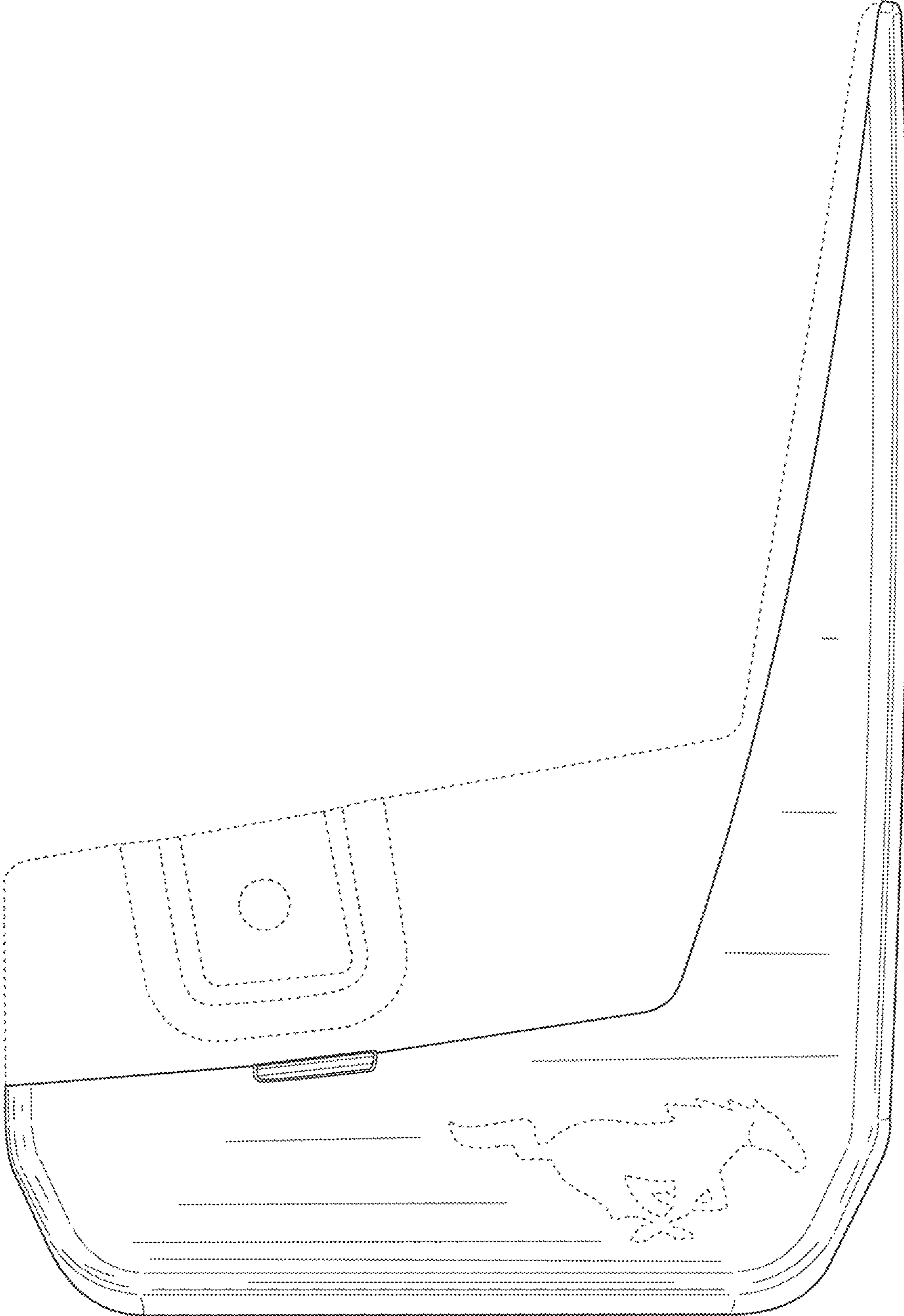

FIG. 10

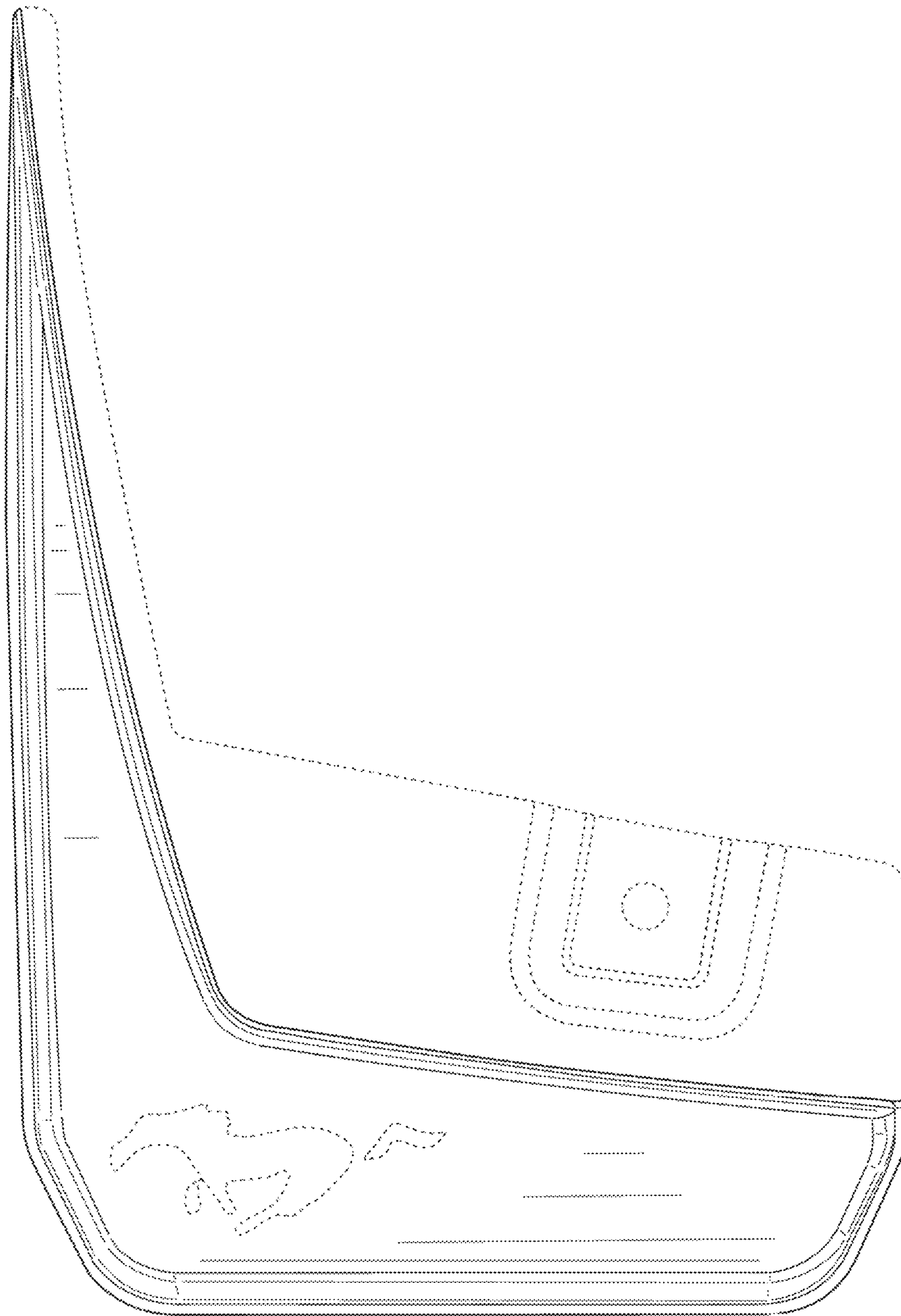

FIG. 11

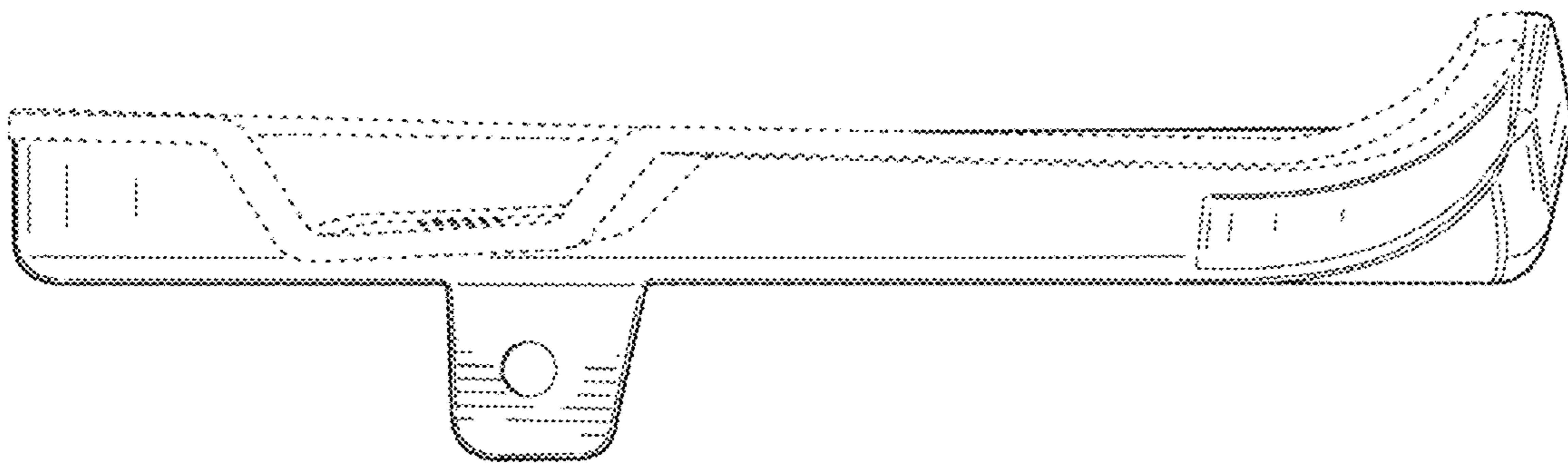
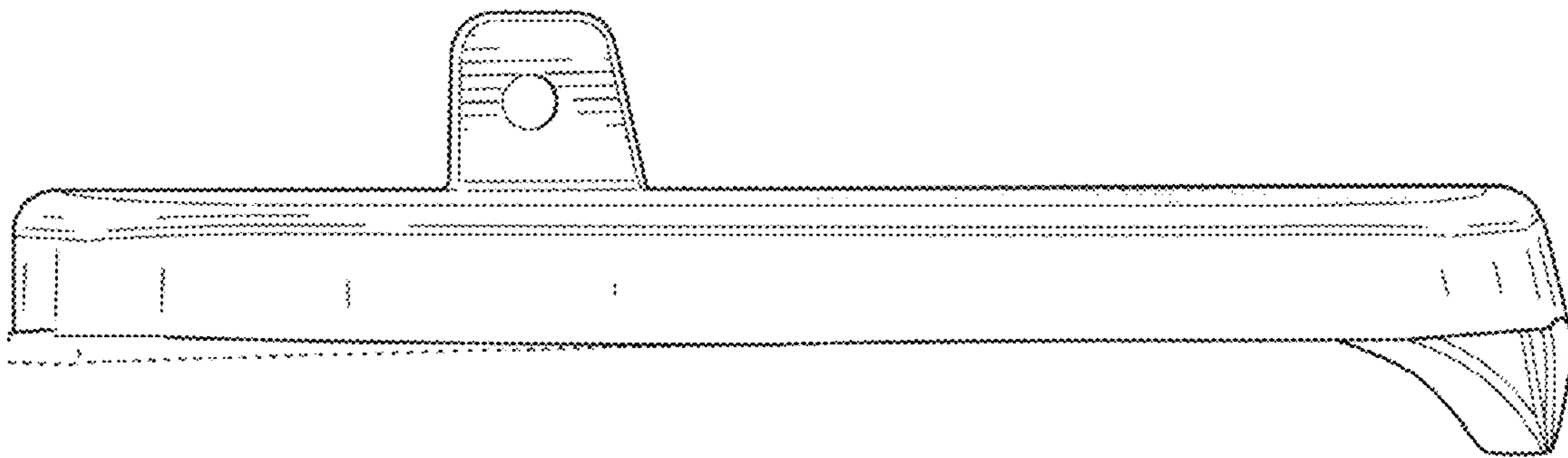

FIG. 12



*FIG. 13*

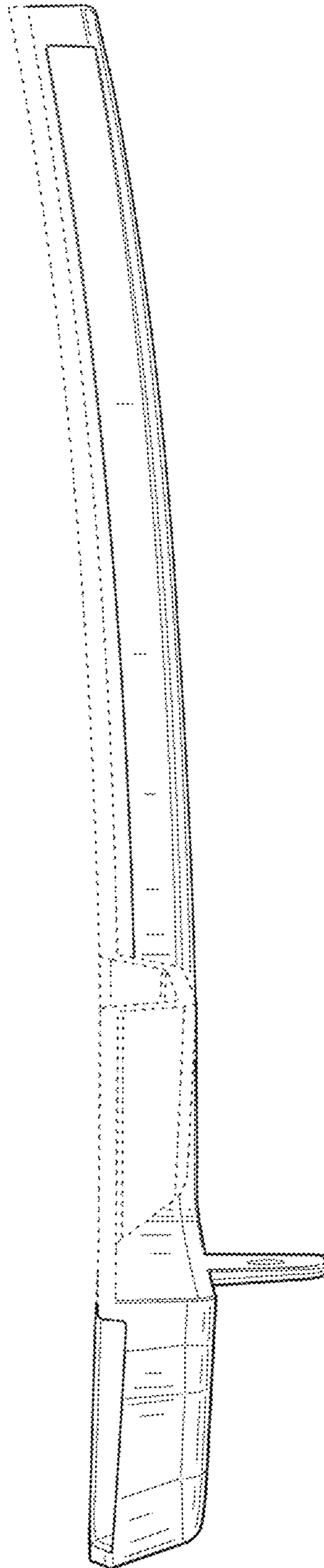
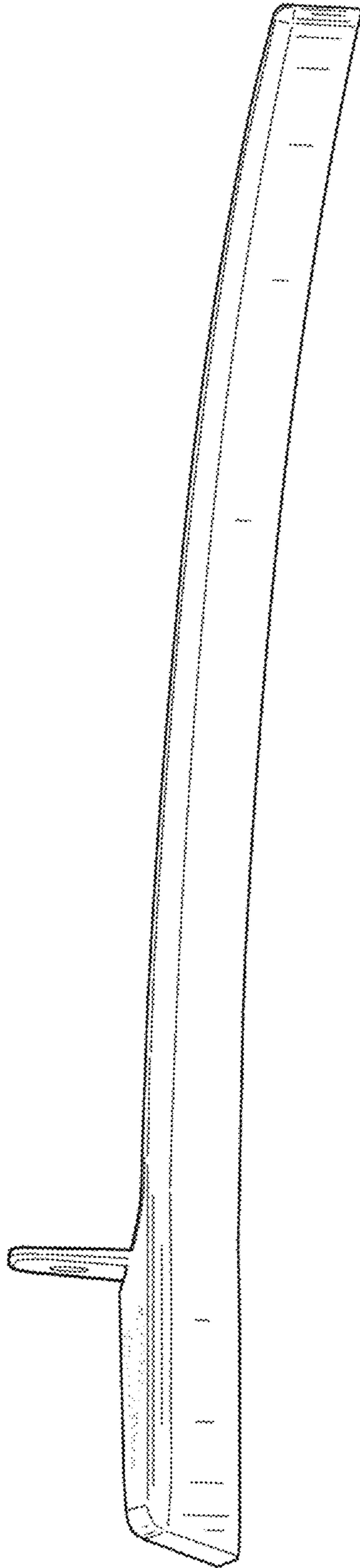

FIG. 14





**FIG. 15**