



US00D904252S

(12) **United States Design Patent**
Duncan et al.

(10) **Patent No.:** **US D904,252 S**
(45) **Date of Patent:** **** Dec. 8, 2020**

(54) **STALK MOUNTED AUTOMATED MANUAL SHIFTER**

(71) Applicant: **PACCAR Inc**, Bellevue, WA (US)

(72) Inventors: **Jonathan S. Duncan**, Seattle, WA (US); **Steven Karl Jahns**, Bellingham, WA (US)

(73) Assignee: **PACCAR Inc**, Bellevue, WA (US)

(**) Term: **15 Years**

(21) Appl. No.: **29/608,680**

(22) Filed: **Jun. 23, 2017**

(51) **LOC (12) Cl.** **12-16**

(52) **U.S. Cl.**
USPC **D12/174; D12/179**

(58) **Field of Classification Search**
USPC D12/400, 415, 162, 174, 175, 176, 177, D12/179, 180, 181, 190, 191, 192, 196,
(Continued)

(56) **References Cited**

U.S. PATENT DOCUMENTS

D256,575 S * 8/1980 Moore D12/174
4,219,706 A * 8/1980 Koch B60Q 1/1476
200/4

(Continued)

OTHER PUBLICATIONS

“Model 357,” Peterbilt Motors Company, Denton, Texas, May 1994, 3-page brochure.

(Continued)

Primary Examiner — Susan E Krakower

Assistant Examiner — Jerry Shiuan-Hua Hsu

(74) *Attorney, Agent, or Firm* — Seed IP Law Group LLP; Jared M. Barrett

(57) **CLAIM**

The ornamental design for a stalk mounted automated manual shifter, as shown and described.

DESCRIPTION

FIG. 1 is a perspective view of a stalk mounted automated manual shifter according to an embodiment of our new design;

FIG. 2 is a first side elevational view of the stalk mounted automated manual shifter shown in FIG. 1;

FIG. 3 is a second side elevational view of the stalk mounted automated manual shifter shown in FIG. 1;

FIG. 4 is top plan view of the stalk mounted automated manual shifter shown in FIG. 1;

FIG. 5 is a bottom plan view of the stalk mounted automated manual shifter shown in FIG. 1;

FIG. 6 is a rear elevational view of the stalk mounted automated manual shifter shown in FIG. 1;

FIG. 7 is a front elevational view of the stalk mounted automated manual shifter shown in FIG. 1;

FIG. 8 is a perspective view of a stalk mounted automated manual shifter according to another embodiment of our new design;

FIG. 9 is a first side elevational view of the stalk mounted automated manual shifter shown in FIG. 8;

FIG. 10 is a second side elevational view of the stalk mounted automated manual shifter shown in FIG. 8;

FIG. 11 is top plan view of the stalk mounted automated manual shifter shown in FIG. 8;

FIG. 12 is a bottom plan view of the stalk mounted automated manual shifter shown in FIG. 8;

FIG. 13 is a rear elevational view of the stalk mounted automated manual shifter shown in FIG. 8;

FIG. 14 is a front elevational view of the stalk mounted automated manual shifter shown in FIG. 8;

FIG. 15 is a perspective view of a stalk mounted automated manual shifter according to another embodiment of our new design;

FIG. 16 is a first side elevational view of the stalk mounted automated manual shifter shown in FIG. 15;

FIG. 17 is a second side elevational view of the stalk mounted automated manual shifter shown in FIG. 15;

(Continued)

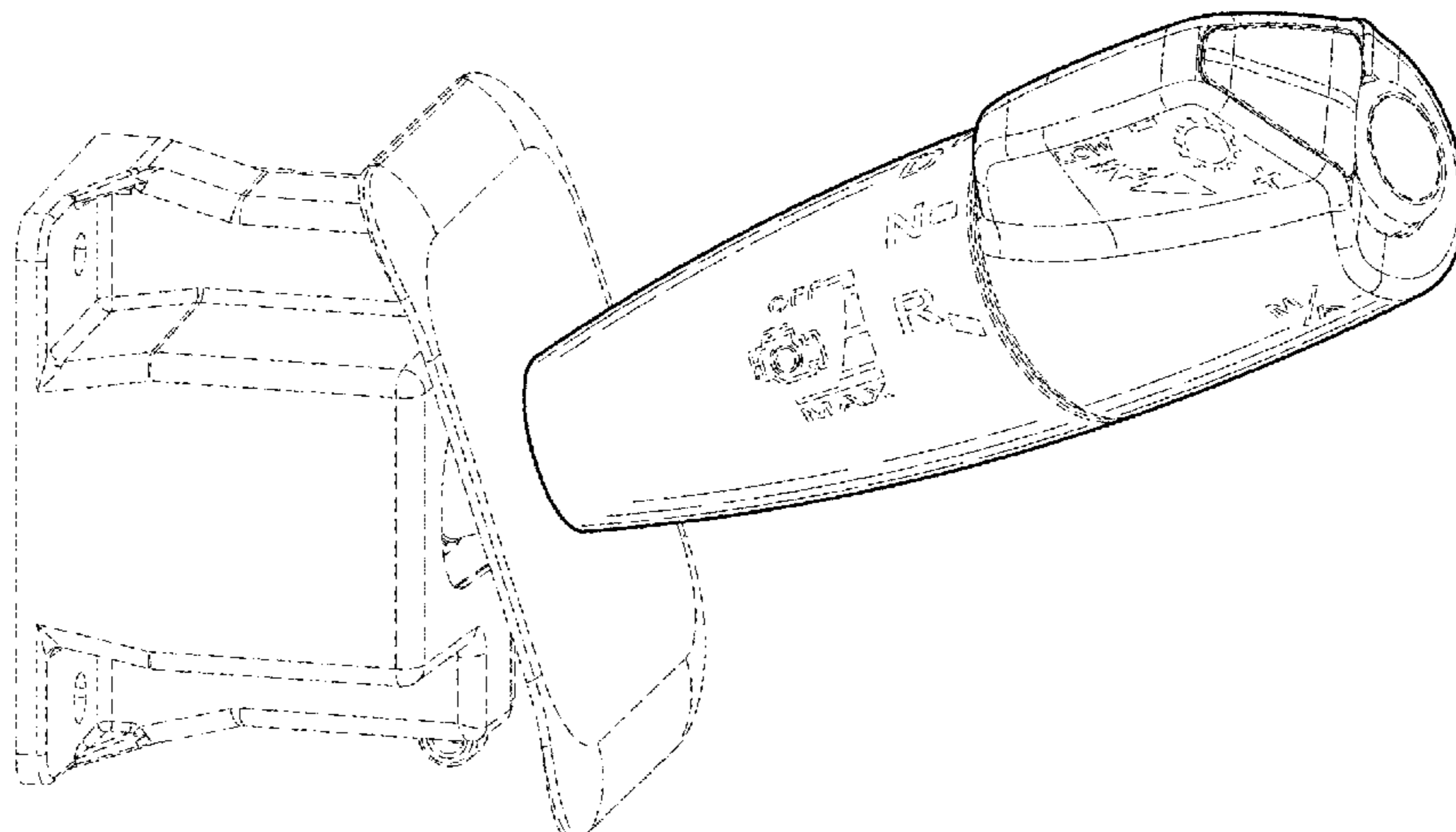

FIG. 18 is top plan view of the stalk mounted automated manual shifter shown in FIG. 15;
 FIG. 19 is a bottom plan view of the stalk mounted automated manual shifter shown in FIG. 15;
 FIG. 20 is a rear elevational view of the stalk mounted automated manual shifter shown in FIG. 15;
 FIG. 21 is a front elevational view of the stalk mounted automated manual shifter shown in FIG. 15;
 FIG. 22 is a perspective view of a stalk mounted automated manual shifter according to another embodiment of our new design;
 FIG. 23 is a first side elevational view of the stalk mounted automated manual shifter shown in FIG. 22;
 FIG. 24 is a second side elevational view of the stalk mounted automated manual shifter shown in FIG. 22;
 FIG. 25 is top plan view of the stalk mounted automated manual shifter shown in FIG. 22;
 FIG. 26 is a bottom plan view of the stalk mounted automated manual shifter shown in FIG. 22;
 FIG. 27 is a rear elevational view of the stalk mounted automated manual shifter shown in FIG. 22; and,
 FIG. 28 is a front elevational view of the stalk mounted automated manual shifter shown in FIG. 22.
 The broken lines shown in the figures represent portions of the stalk mounted automated manual shifter that form no part of the claimed design.

1 Claim, 28 Drawing Sheets

(58) **Field of Classification Search**

USPC D12/218, 16; D14/412, 415, 416;
 D21/566; D15/5, 7, 28
 CPC F16H 59/0204; B60Q 1/1476
 See application file for complete search history.

(56) **References Cited**

U.S. PATENT DOCUMENTS

D294,243 S *	2/1988	Lane, Jr.	D12/174
D307,736 S *	5/1990	Otteson	D12/174
D413,091 S *	8/1999	DuRocher	D12/174
D458,881 S *	6/2002	Wang	D12/179
D469,724 S *	2/2003	Ramos	D12/179
D491,499 S *	6/2004	Wainwright	D12/179
D495,281 S *	8/2004	Pfeiffer	D12/179
D498,189 S *	11/2004	Ligneau	D12/179
D551,604 S *	9/2007	Kapfenstein	D12/179

D568,795 S *	5/2008	Mozer	D12/174
D599,829 S *	9/2009	Jorgensen	D14/412
D606,100 S *	12/2009	Kobayashi	D15/28
D656,073 S *	3/2012	Foerster	D12/179
D822,561 S *	7/2018	Hochhalter	D12/179
D826,118 S *	8/2018	Ito	D12/179
D859,245 S *	9/2019	Tseng	D12/174
D875,003 S *	2/2020	Duncan	D12/179
2017/0356543 A1 *	12/2017	Turney	F16H 59/0204

OTHER PUBLICATIONS

“Model 357-115,” Peterbilt Motors Company, Denton, Texas, Mar. 2005, 2 page brochure.
 “Model 375 Standard Specifications,” Peterbilt Motors Company, Newark, California, Sep. 1986, 6 page brochure.
 “Rest with Class,” Peterbilt Motors Company, Newark, California, Apr. 1978, 4-page brochure.
 “T2000,” Kenworth Truck Company, Kirkland, Washington, 1999, 20-page brochure.
 “T2000,” Kenworth Truck Company, Kirkland, Washington, 2002, 20-page brochure.
 “T300,” Kenworth Truck Company, Kirkland, Washington, 2005, 16-page brochure.
 “T400B and T450B,” Kenworth Truck Company, Kirkland, Washington, 1992, 10-page brochure.
 “T440,” Kenworth Truck Company, Kirkland, Washington, 2010, 6-page brochure.
 “T470,” Kenworth Truck Company, Kirkland, Washington, 2010, 6-page brochure.
 “T470H,” Kenworth Truck Company, Kirkland, Washington, 2009, 2-page brochure.
 “T600, Ten Years of Innovation,” Kenworth Truck Company, Kirkland, Washington, 1995, 6-page brochure.
 “T660,” Kenworth Truck Company, Kirkland, Washington, 2007, 36-page brochure.
 “T800,” Kenworth Truck Company, Kirkland, Washington, 2009, 28-page brochure.
 “T800B,” Kenworth Truck Company, Kirkland, Washington, 1993, 8-page brochure.
 “The Working Class,” Peterbilt Motors Company, Newark, California, Sep. 1976, 6 page brochure.
 “K270,” Kenworth Truck Company, Kirkland, Washington, 2014, 12-page brochure.
 “K370,” Kenworth Truck Company, Kirkland, Washington, 2014, 12-page brochure.
 “T800,” Kenworth Truck Company, Kirkland, Washington, 2012, 28-page brochure.
 “W900,” Kenworth Truck Company, Kirkland, Washington, 2009, 28-page brochure.

* cited by examiner

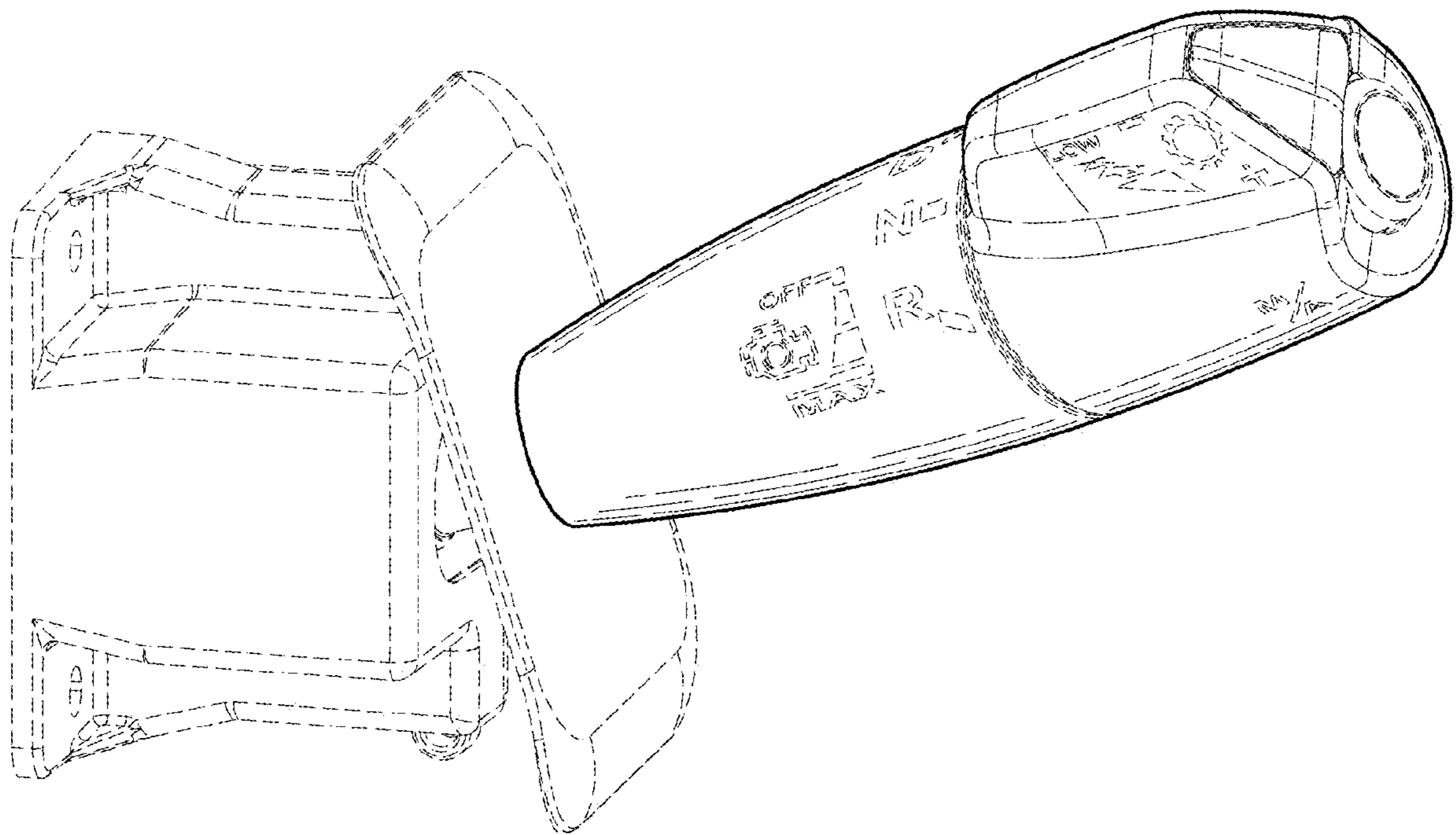

Fig. 1.

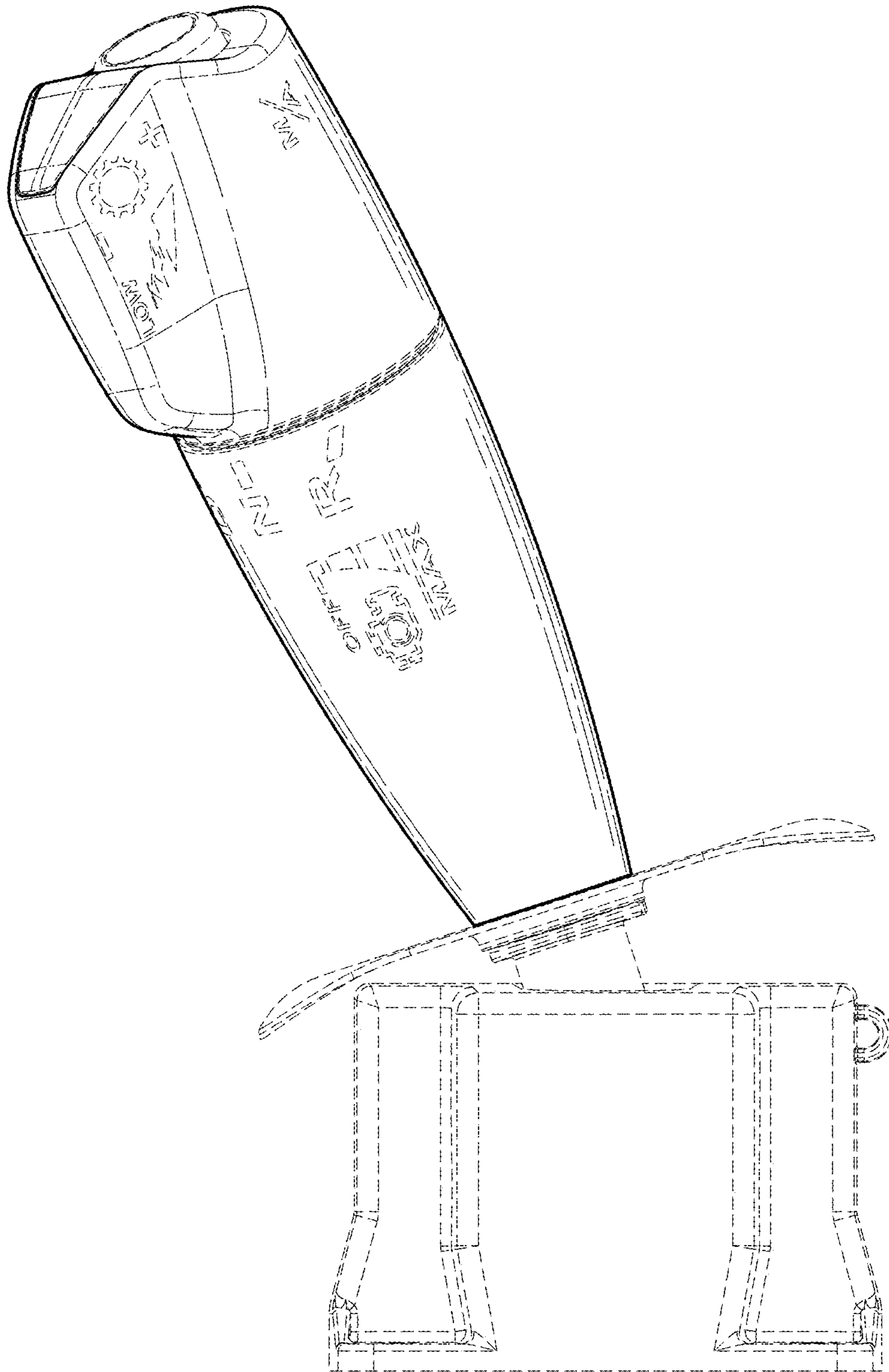

Fig. 2.

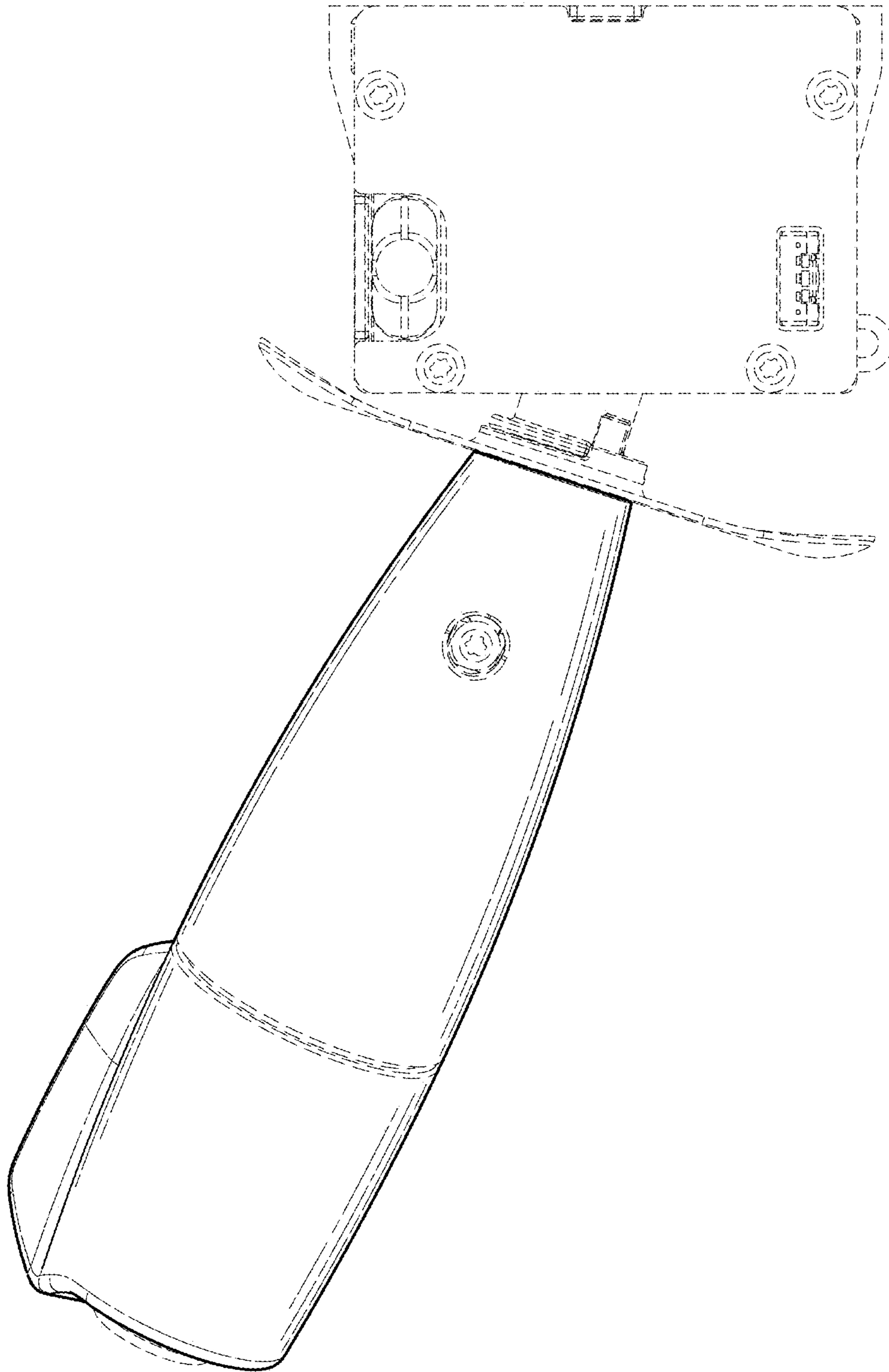

Fig. 3.

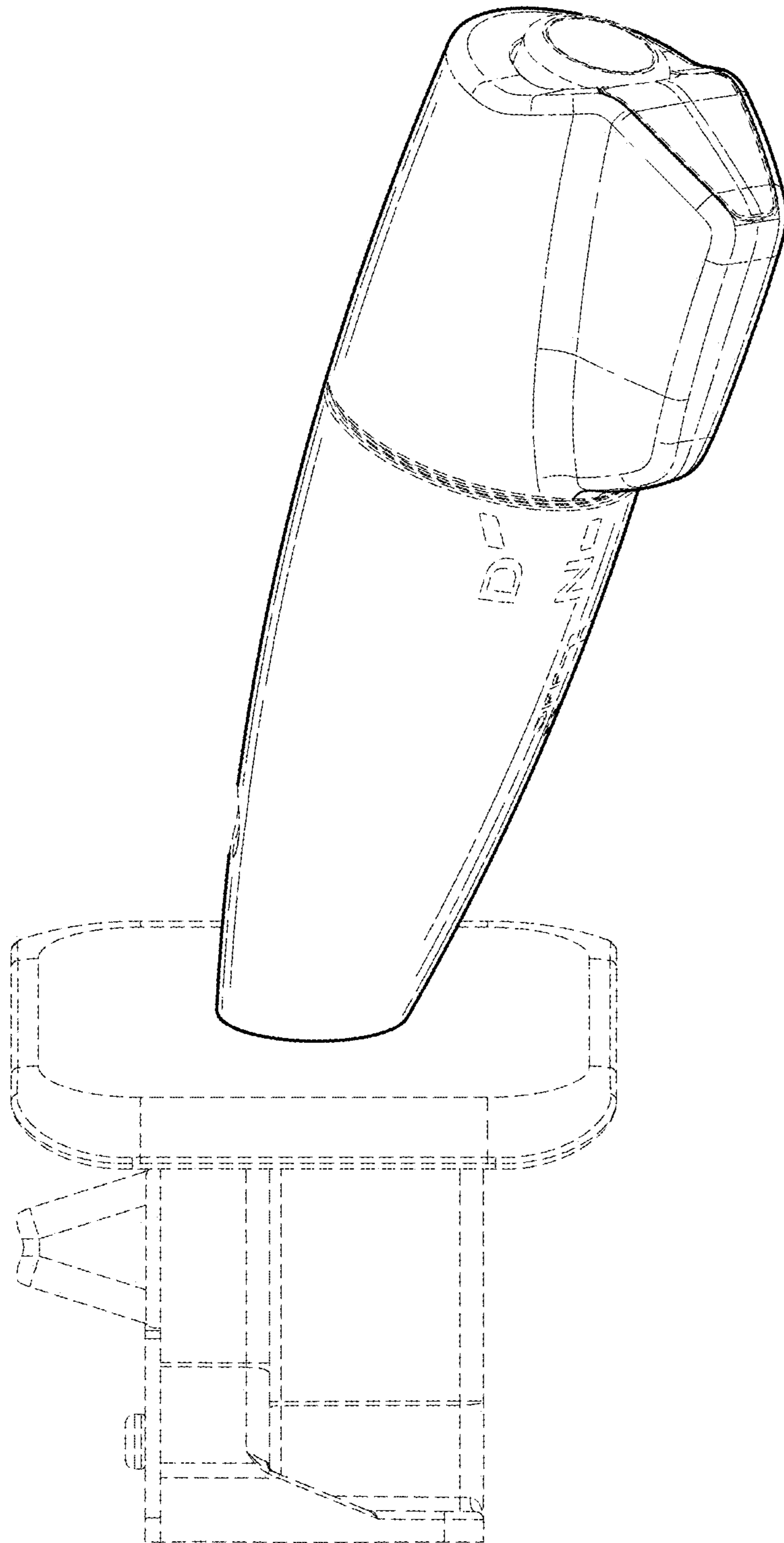

Fig. 4.

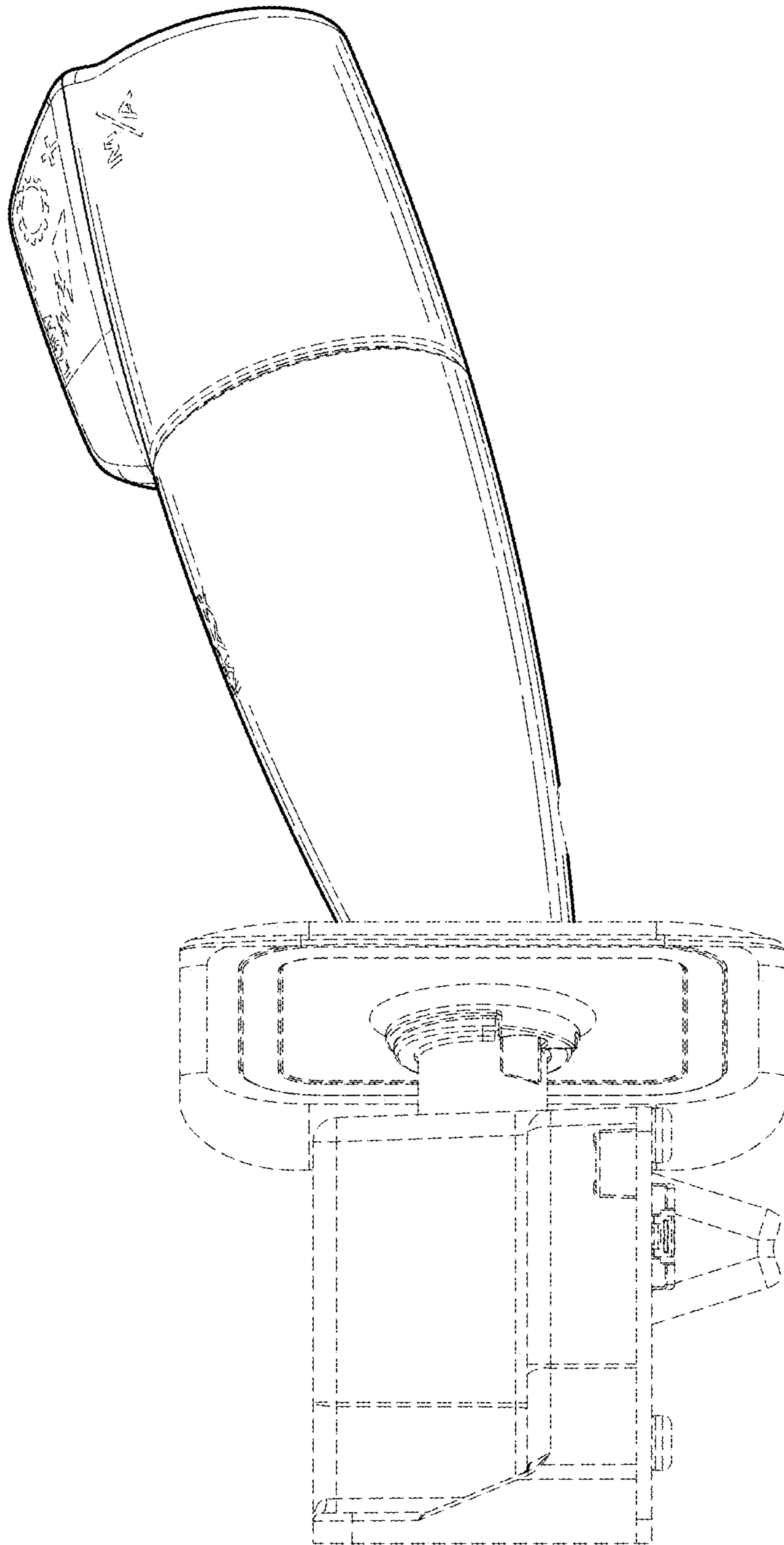

Fig. 5.

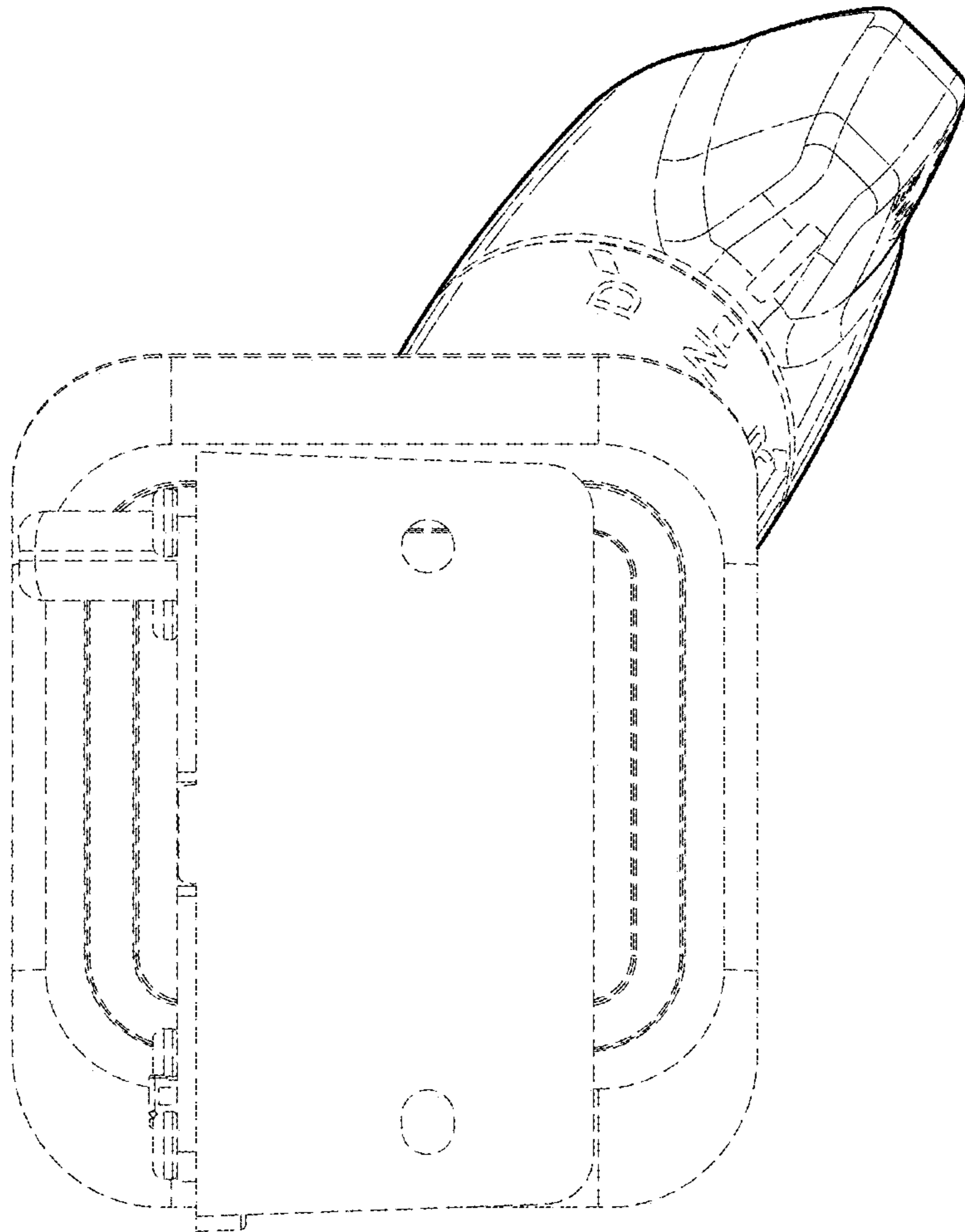

Fig. 6.

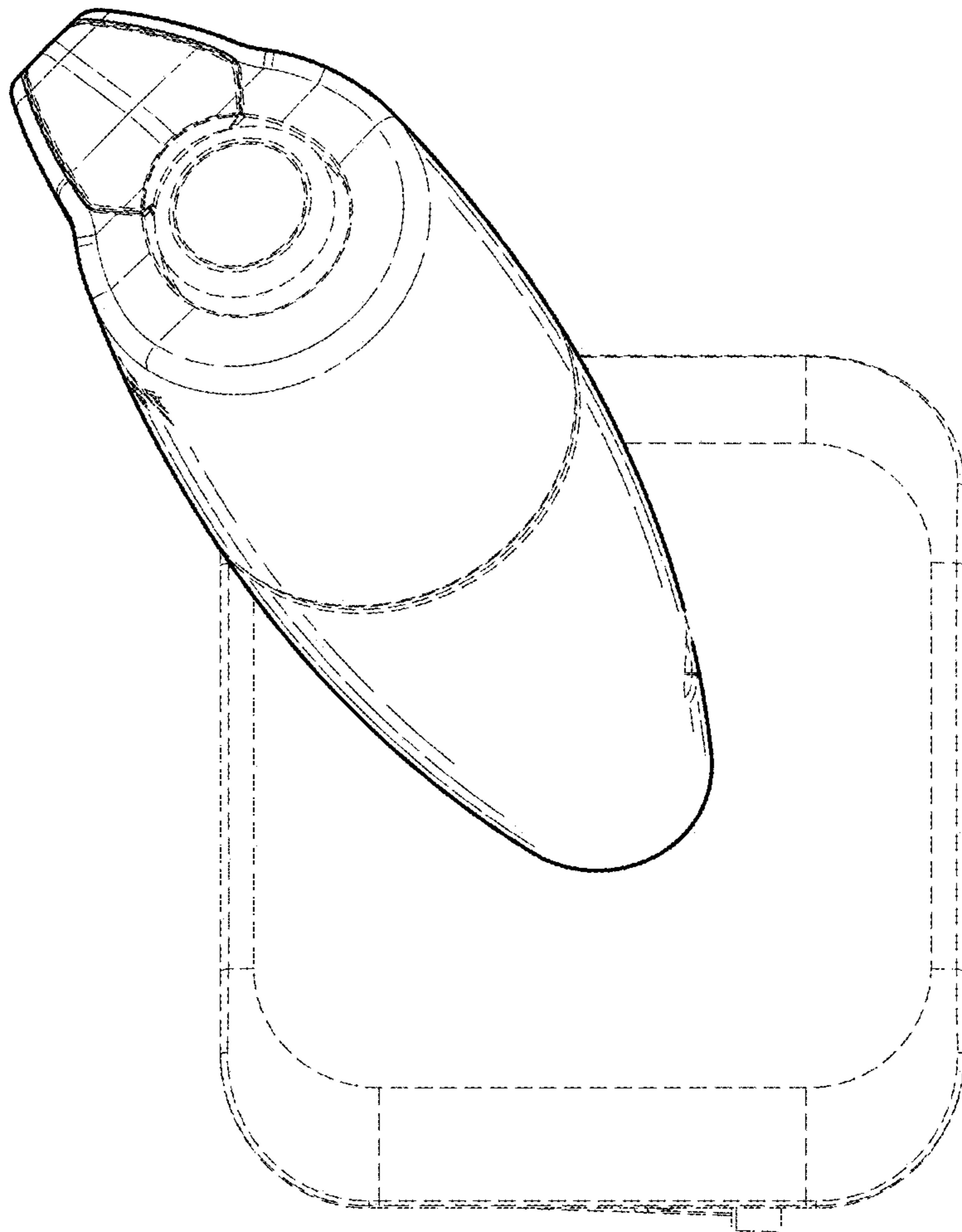

Fig. 7.

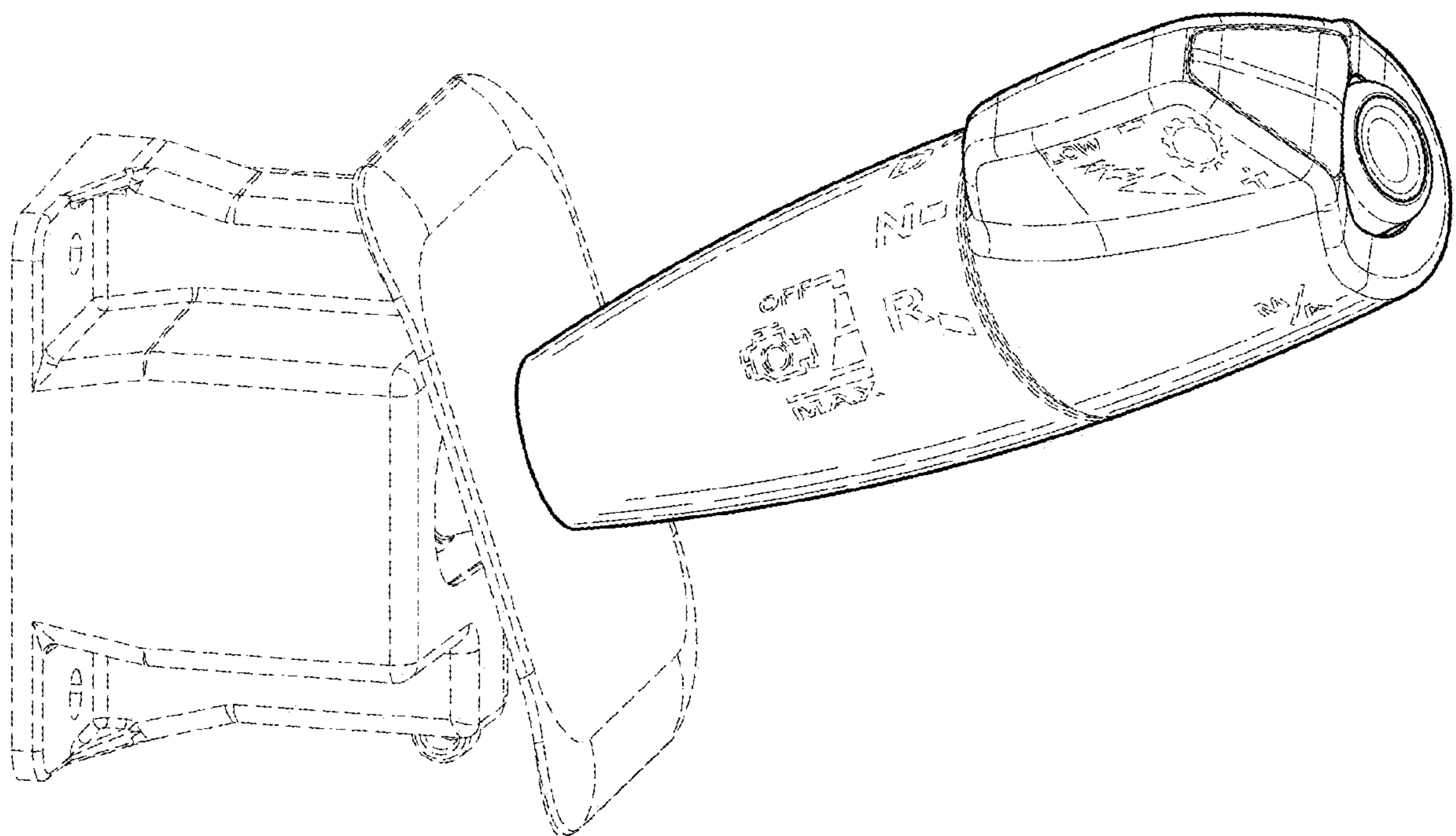

Fig. 8.

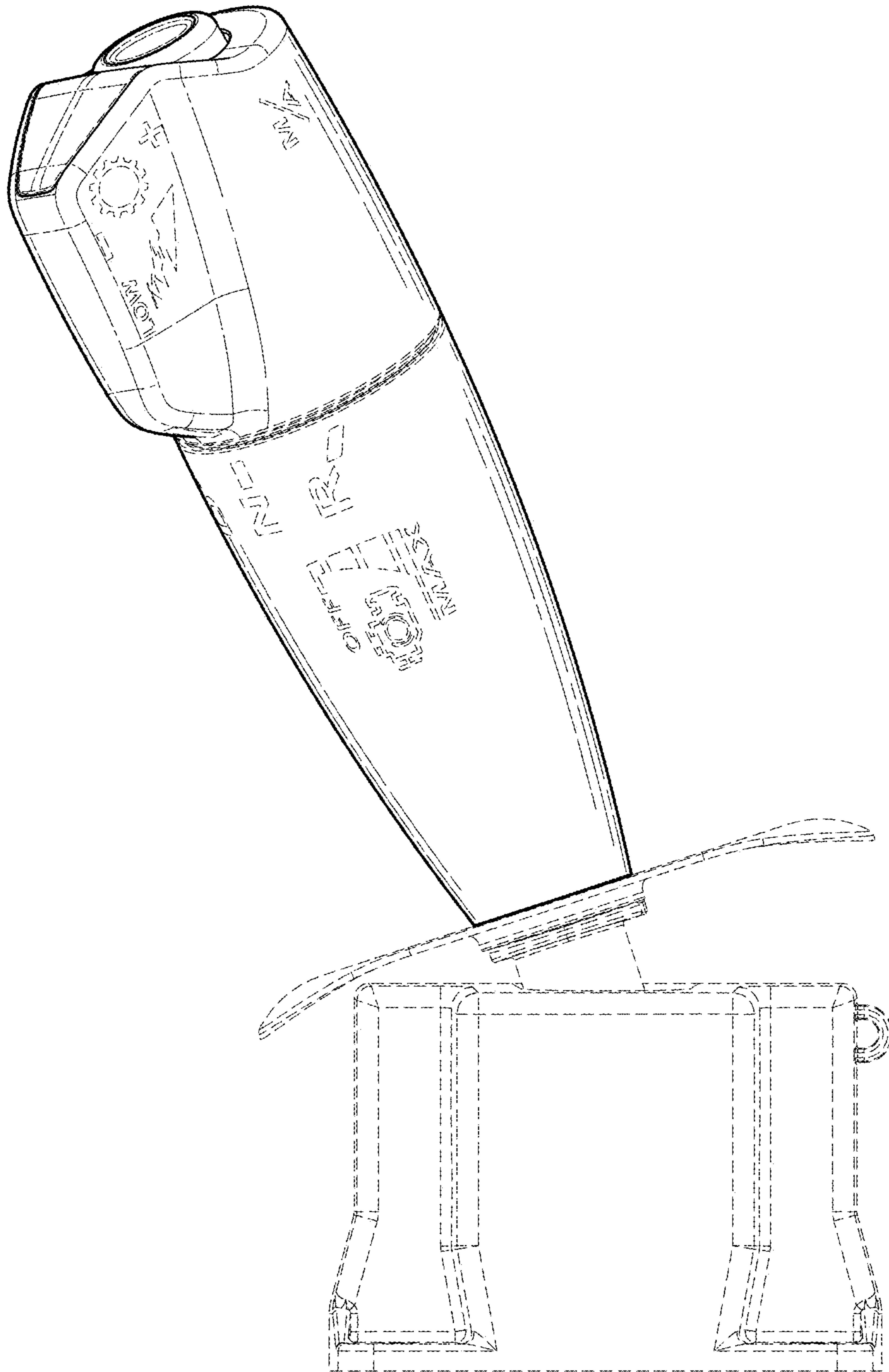

Fig. 9.

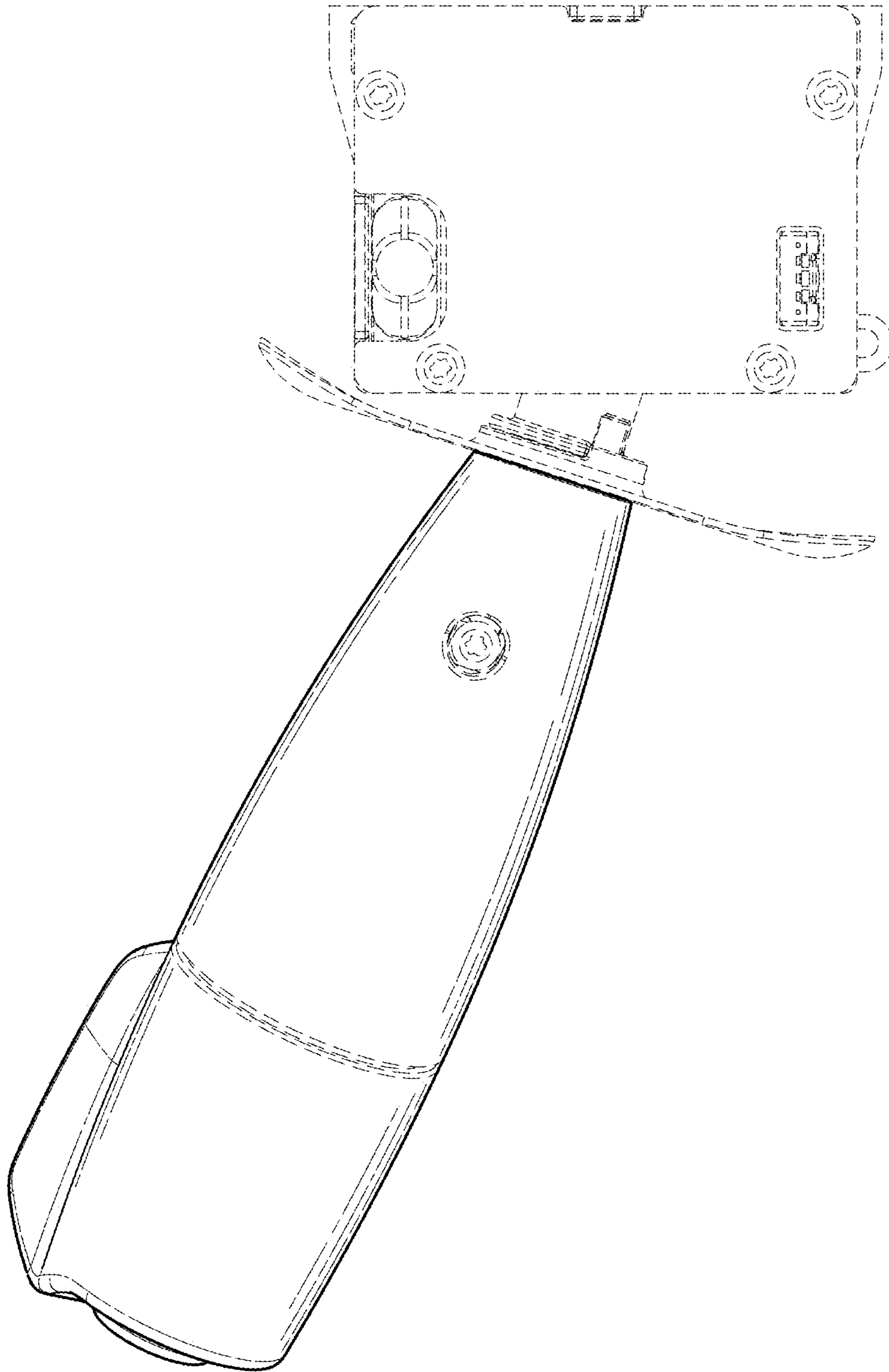

Fig. 10.

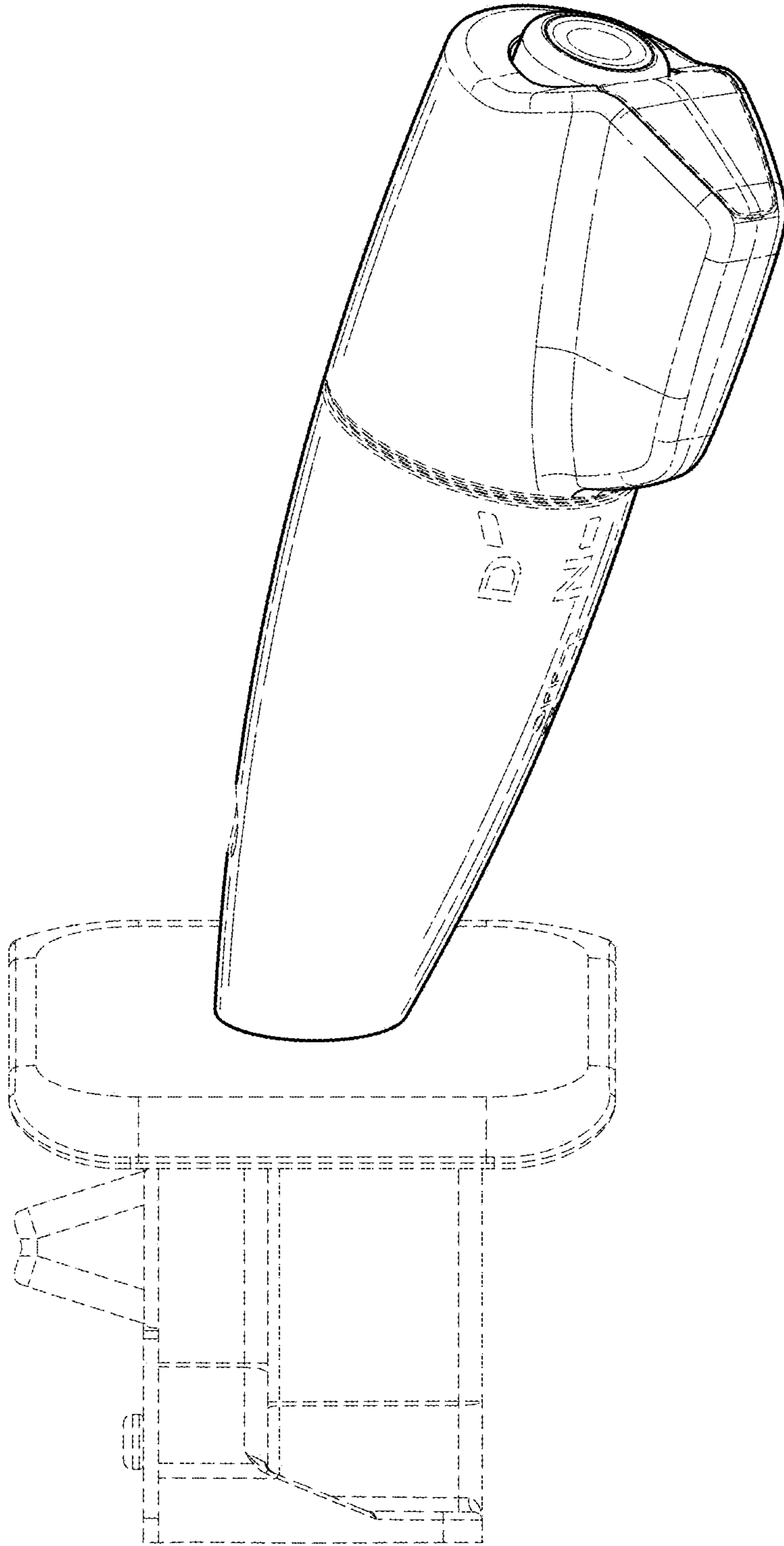

Fig. 11.

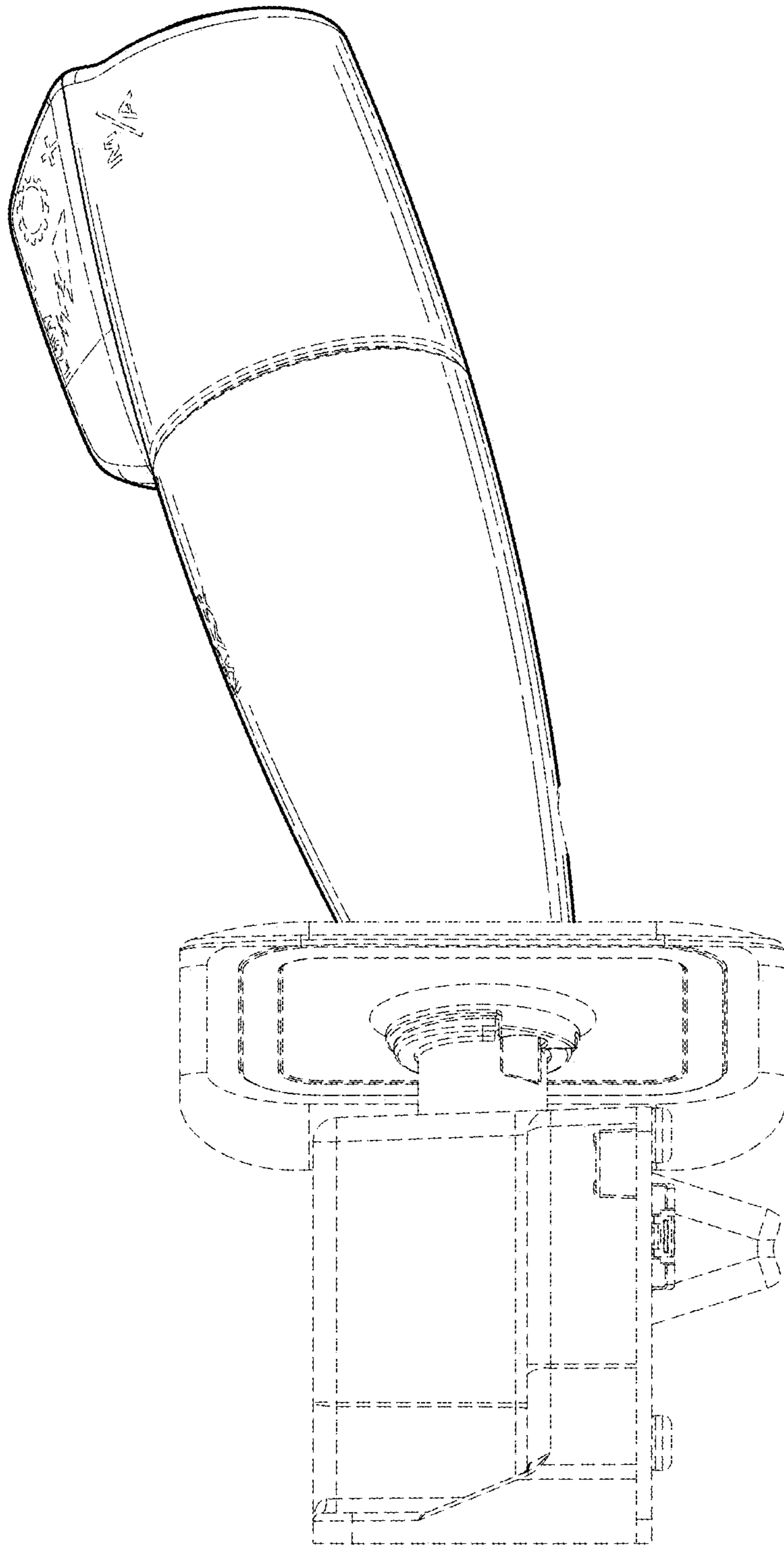

Fig. 12.

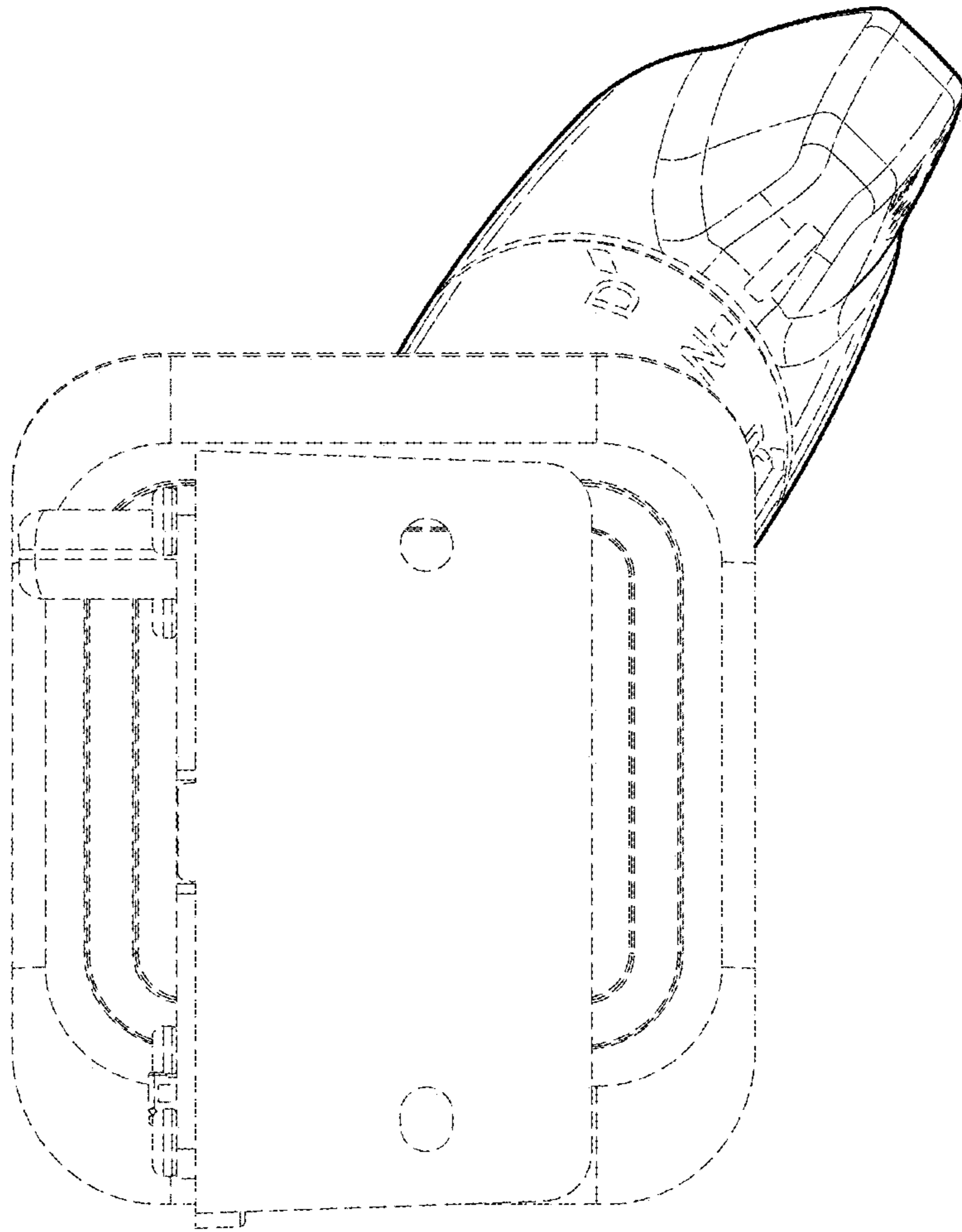

Fig. 13.

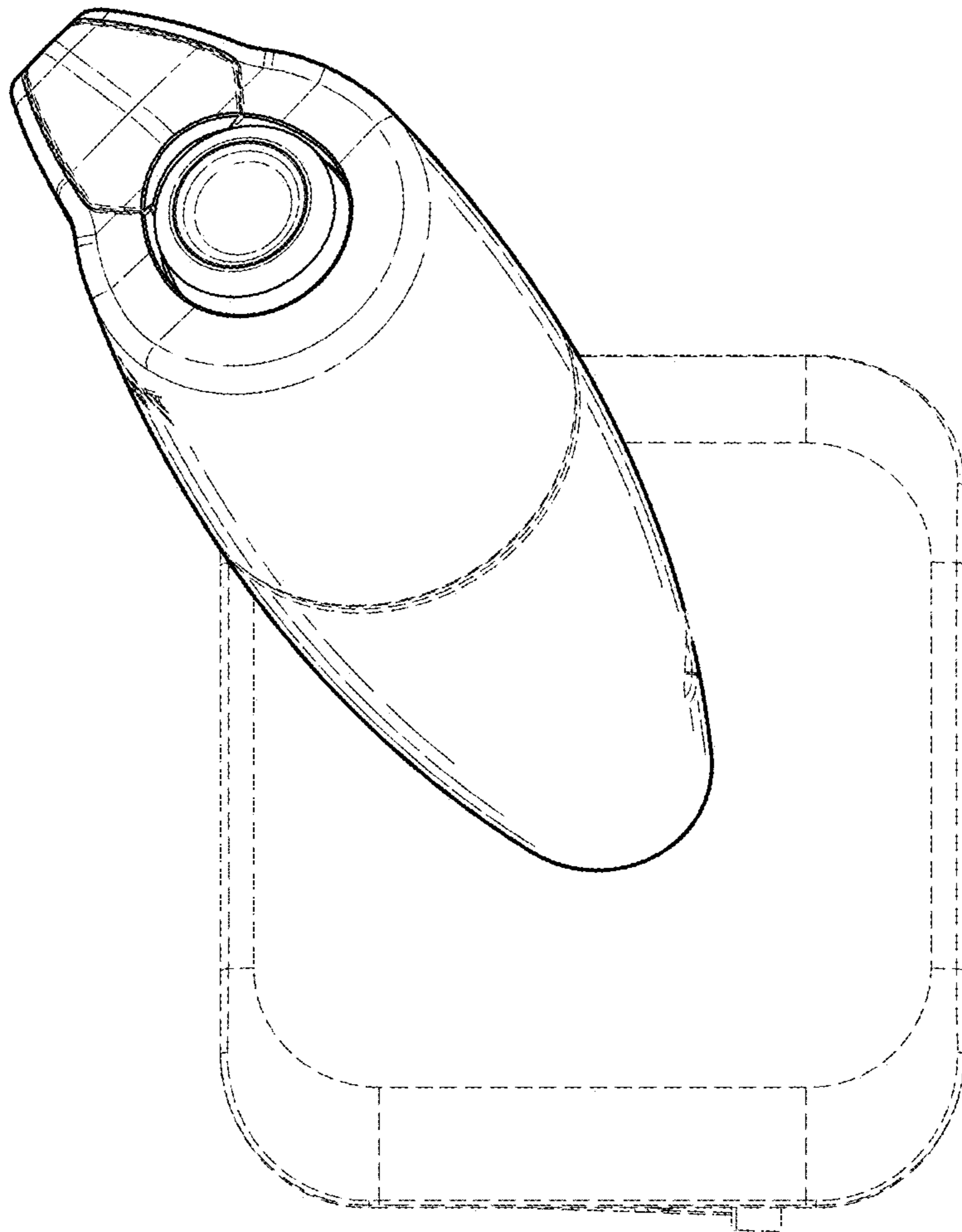

Fig. 14.

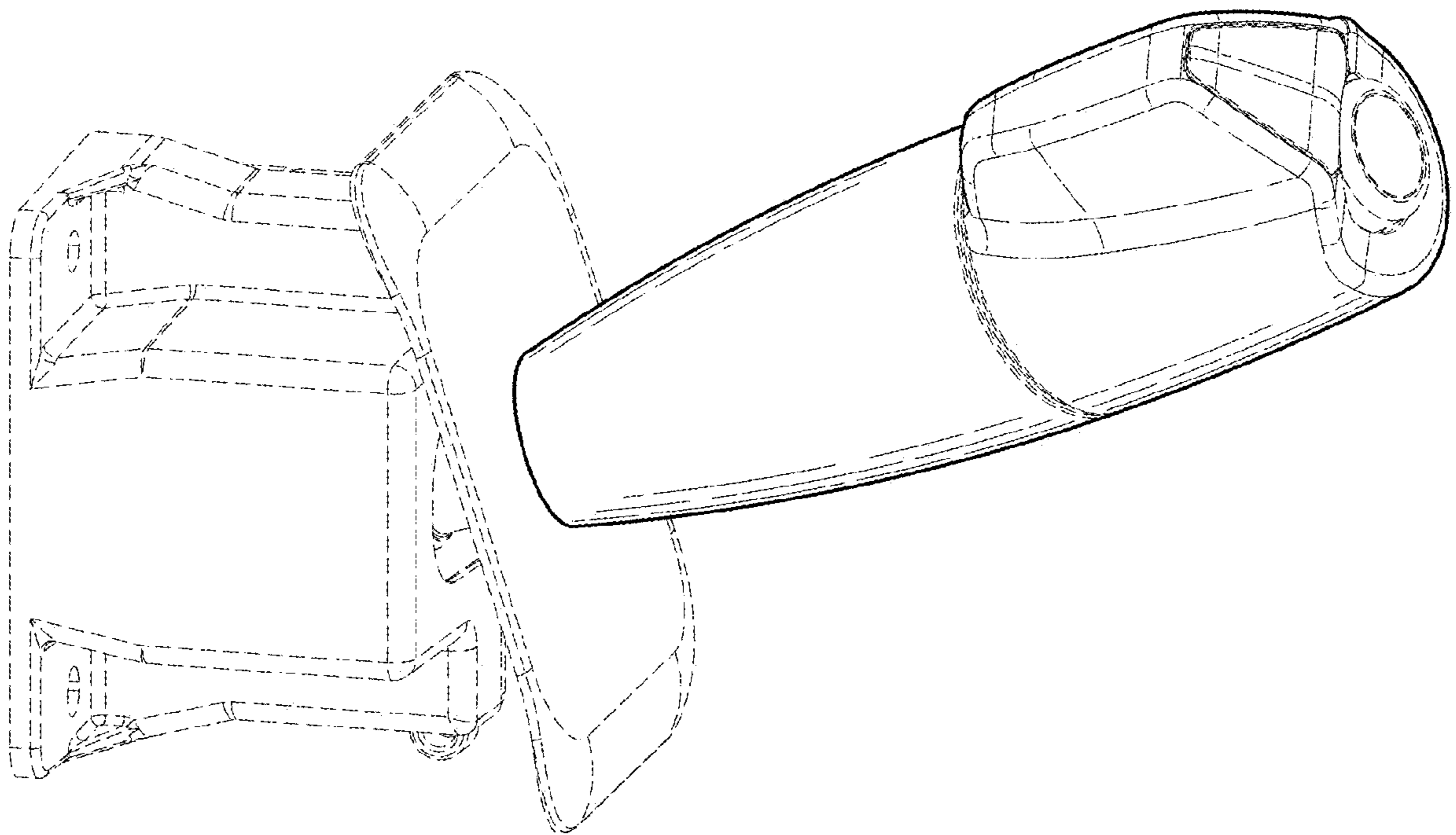

Fig. 15.

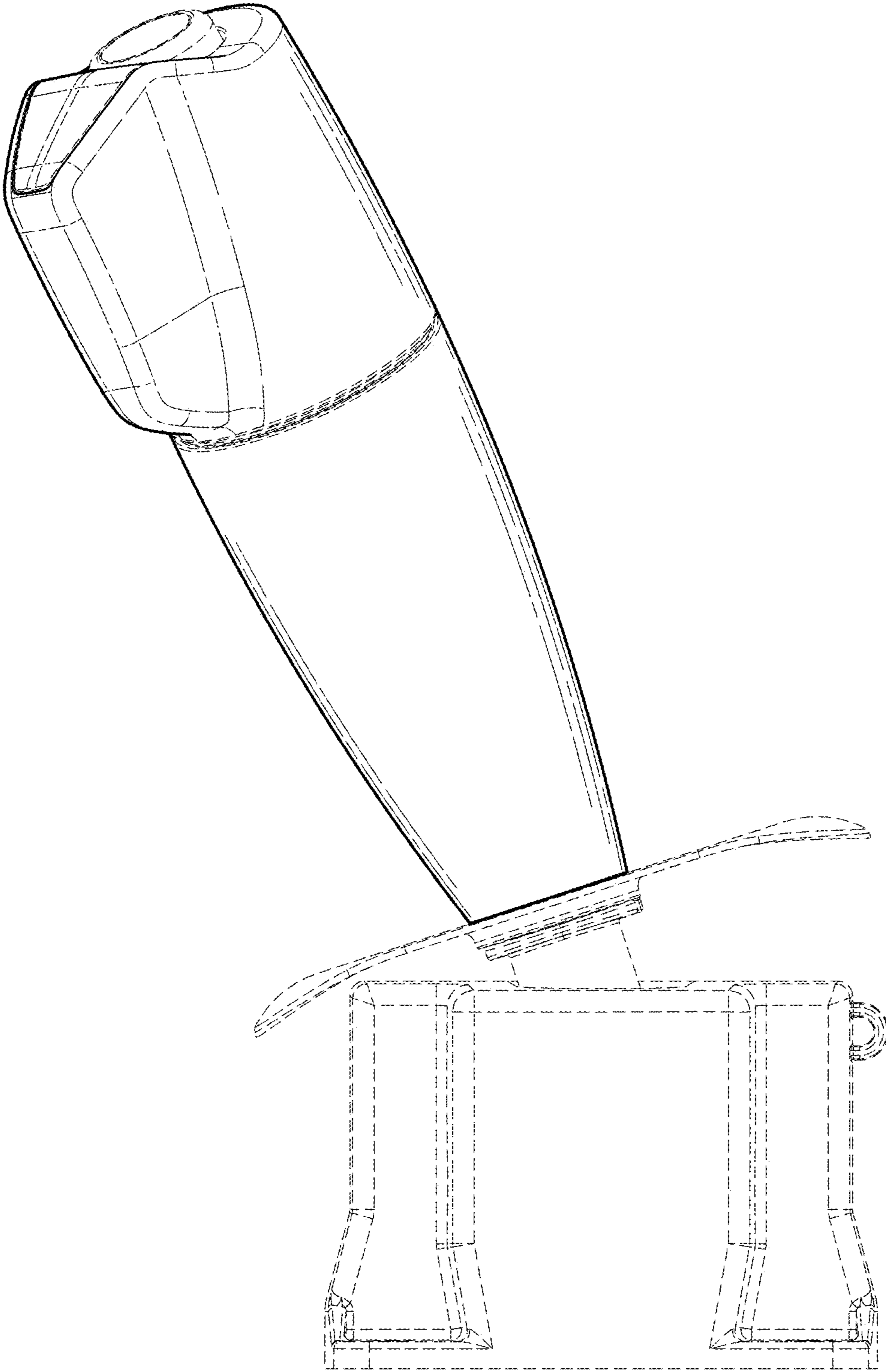

Fig. 16.

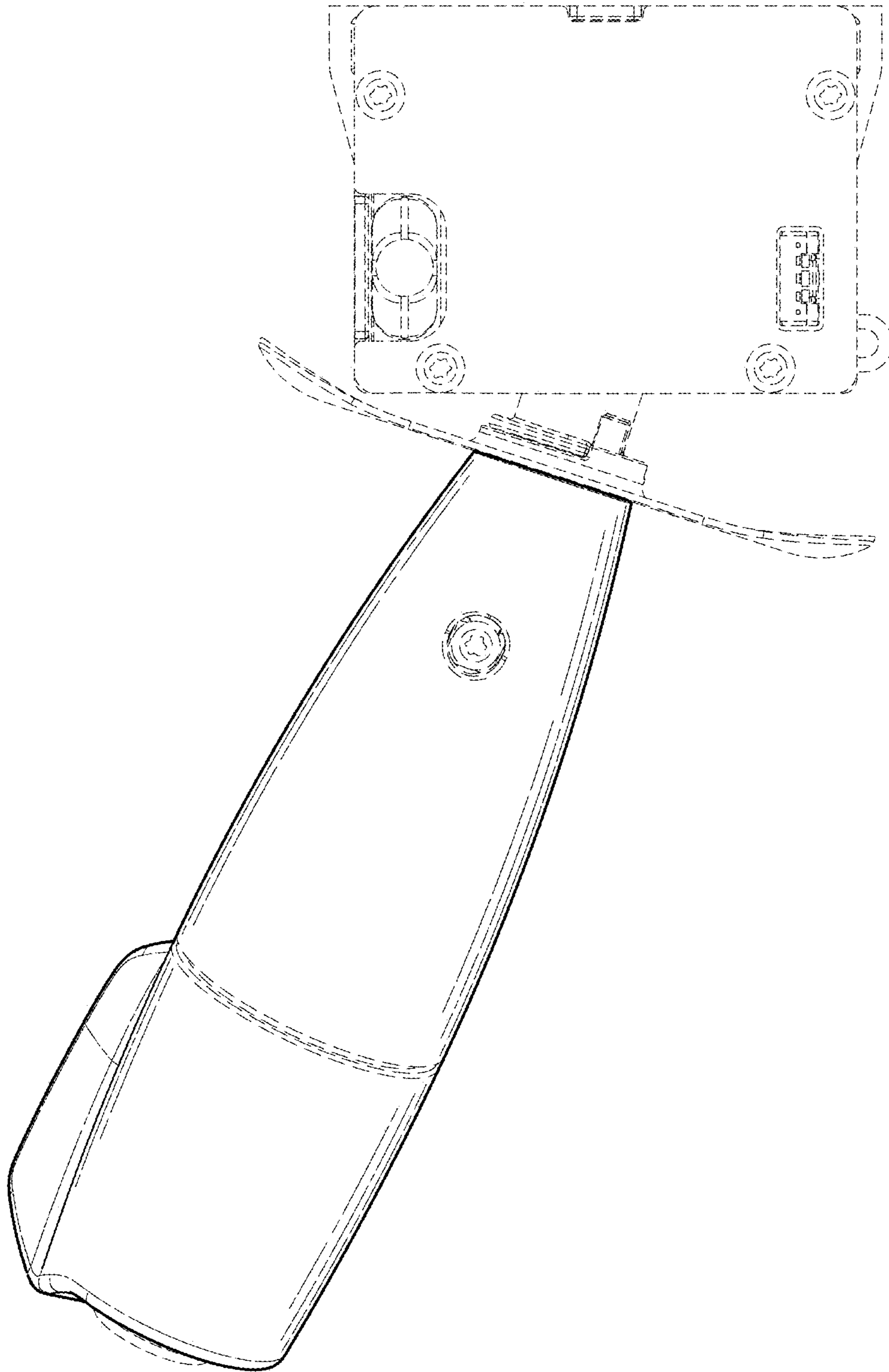

Fig. 17.

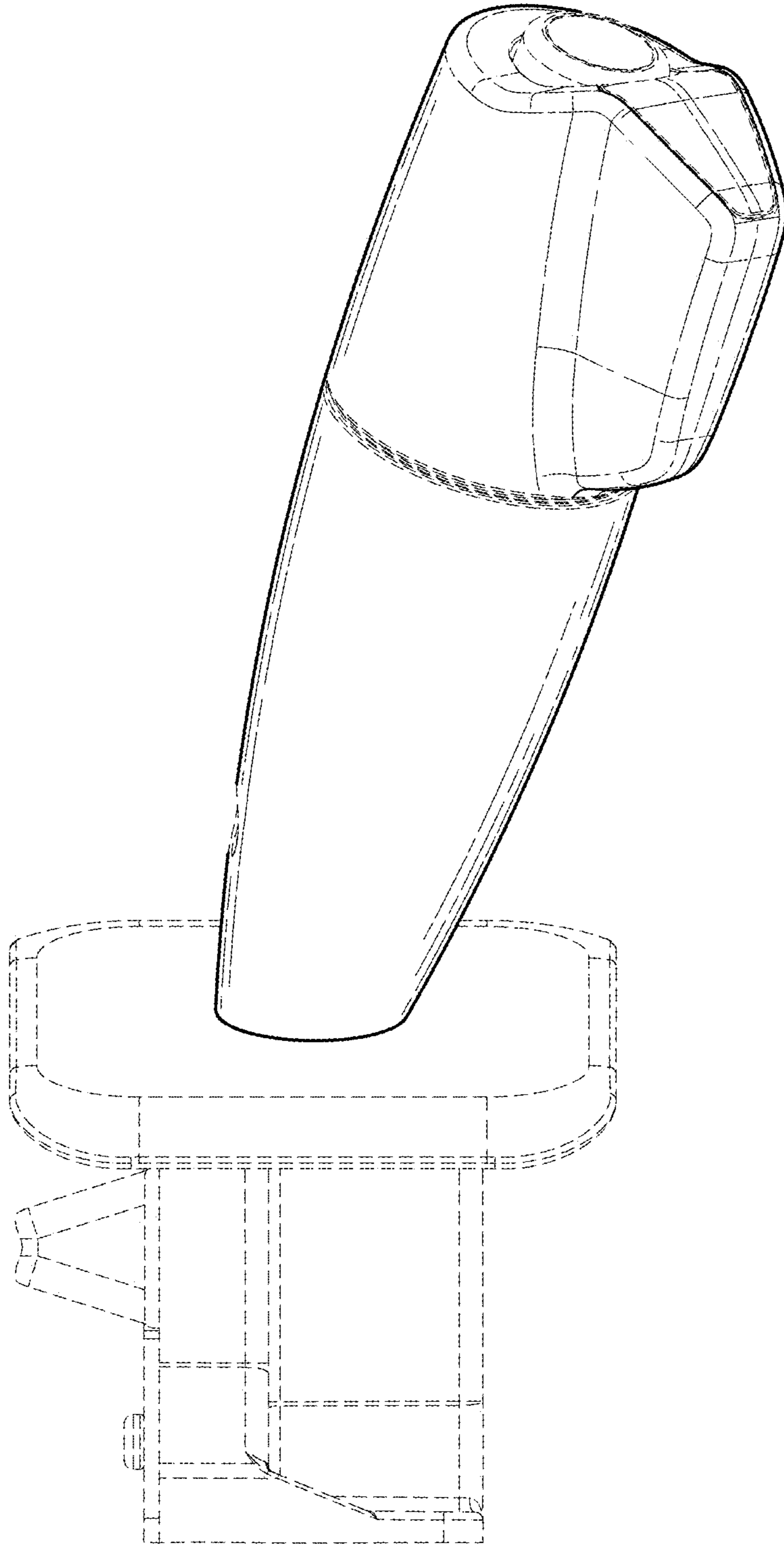

Fig. 18.

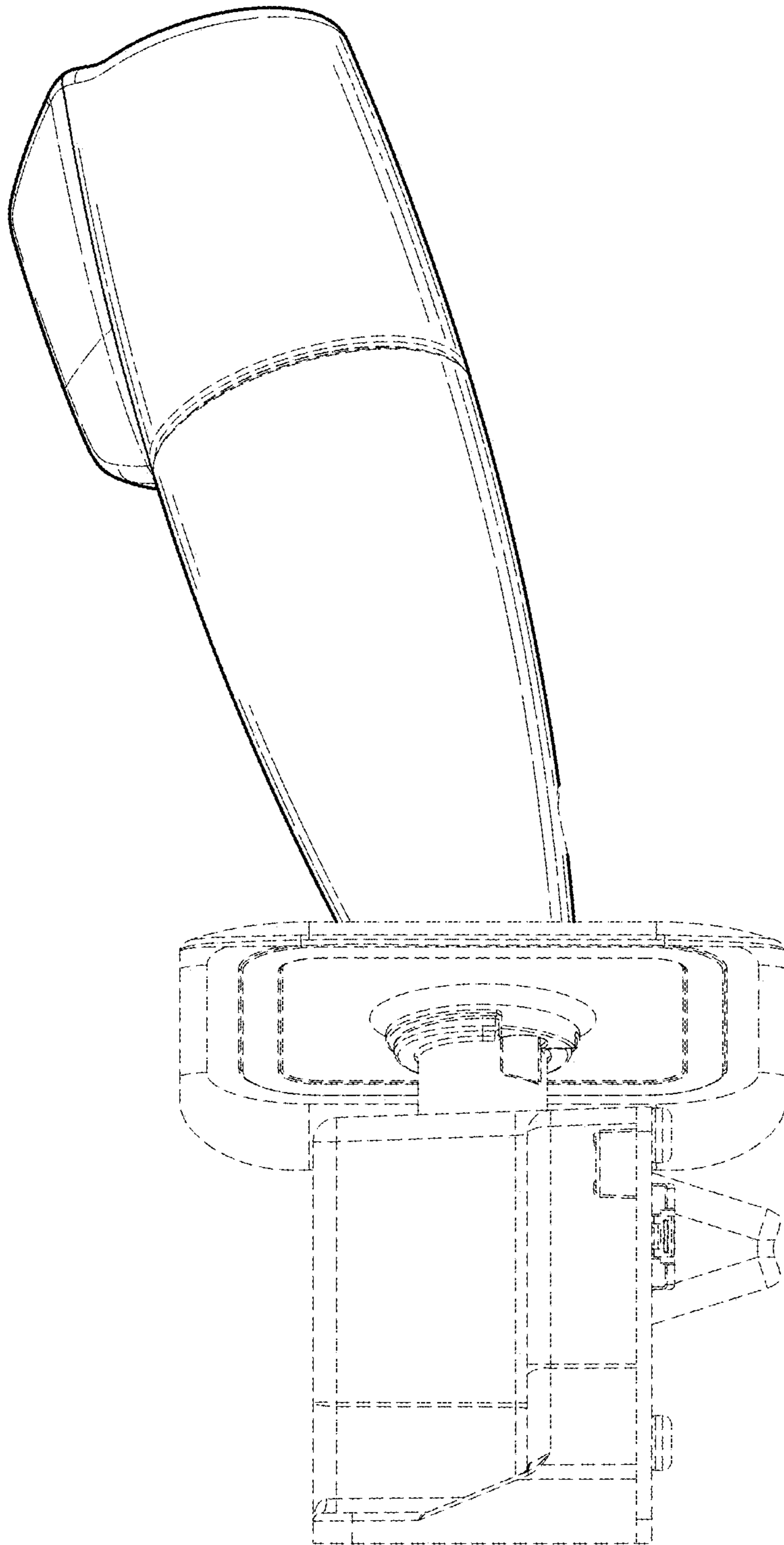

Fig. 19.

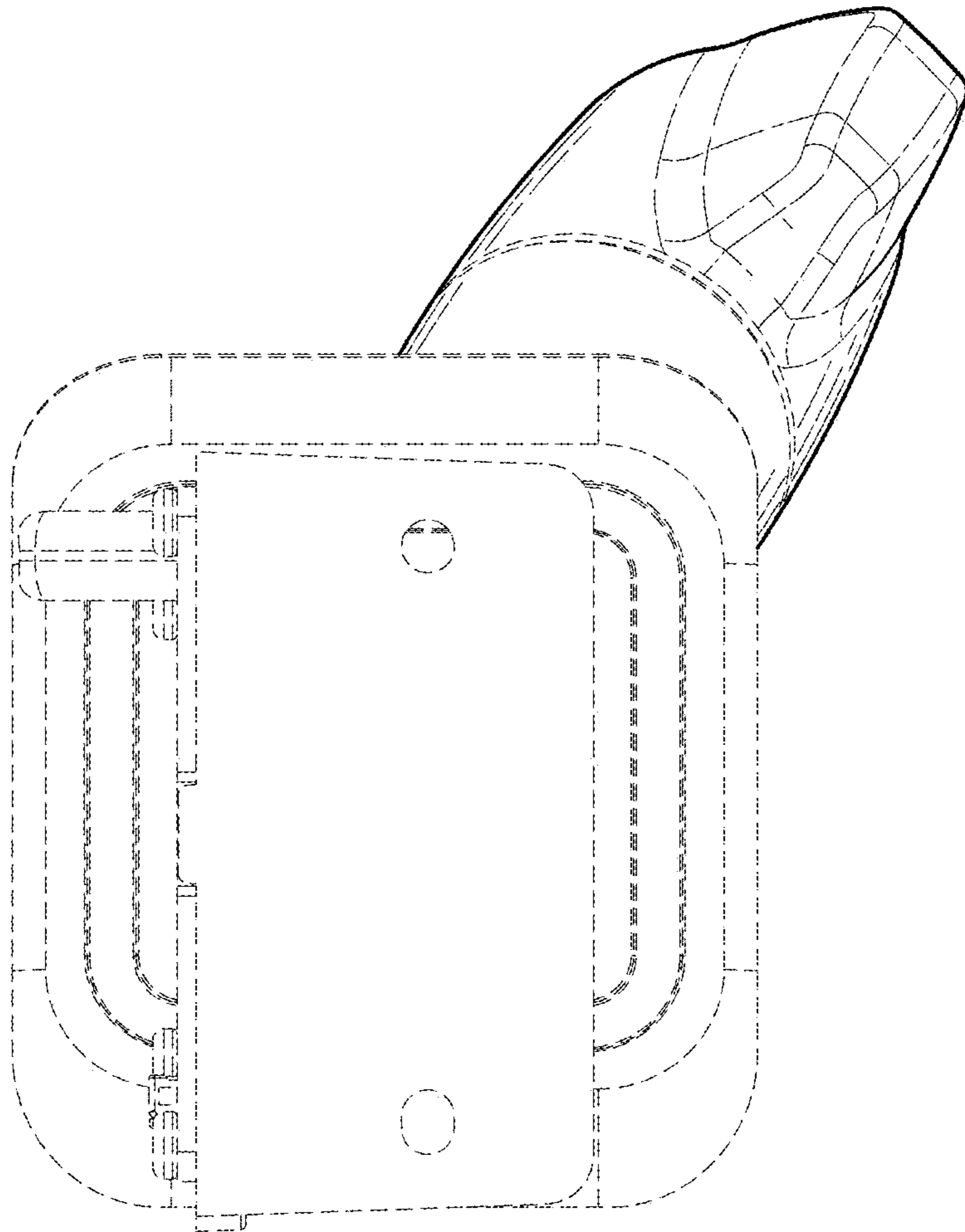

Fig. 20.

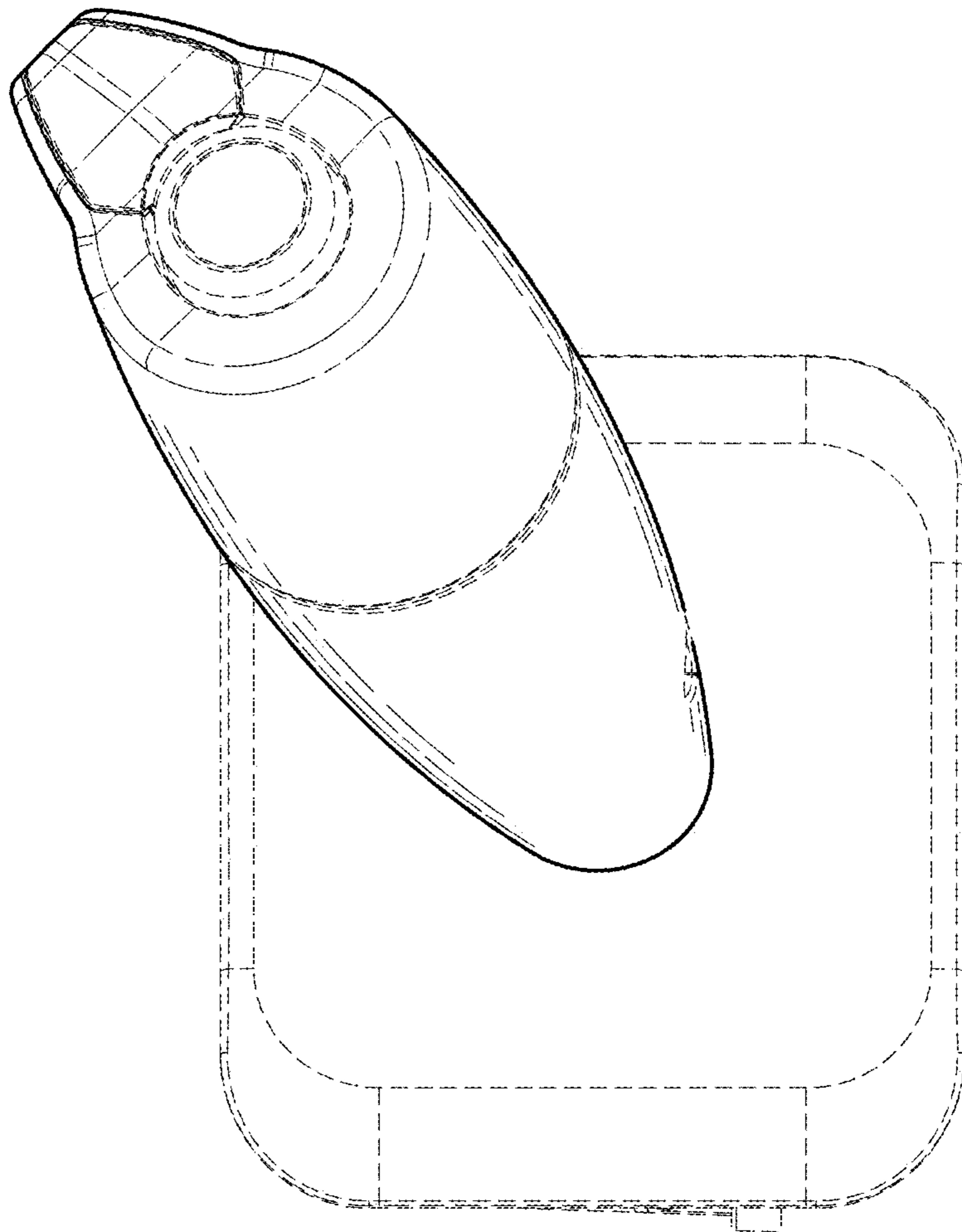

Fig. 21.

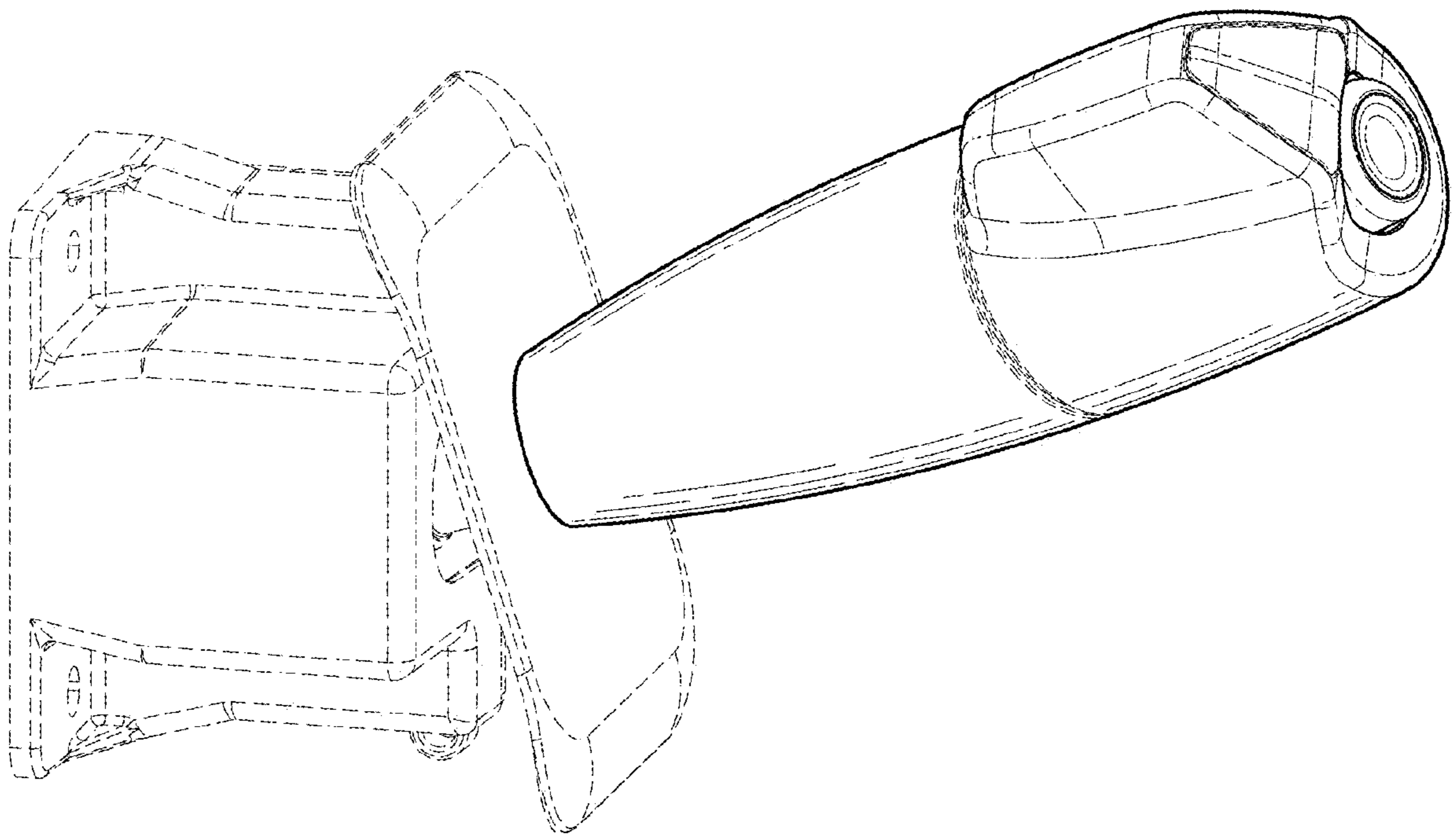

Fig. 22.

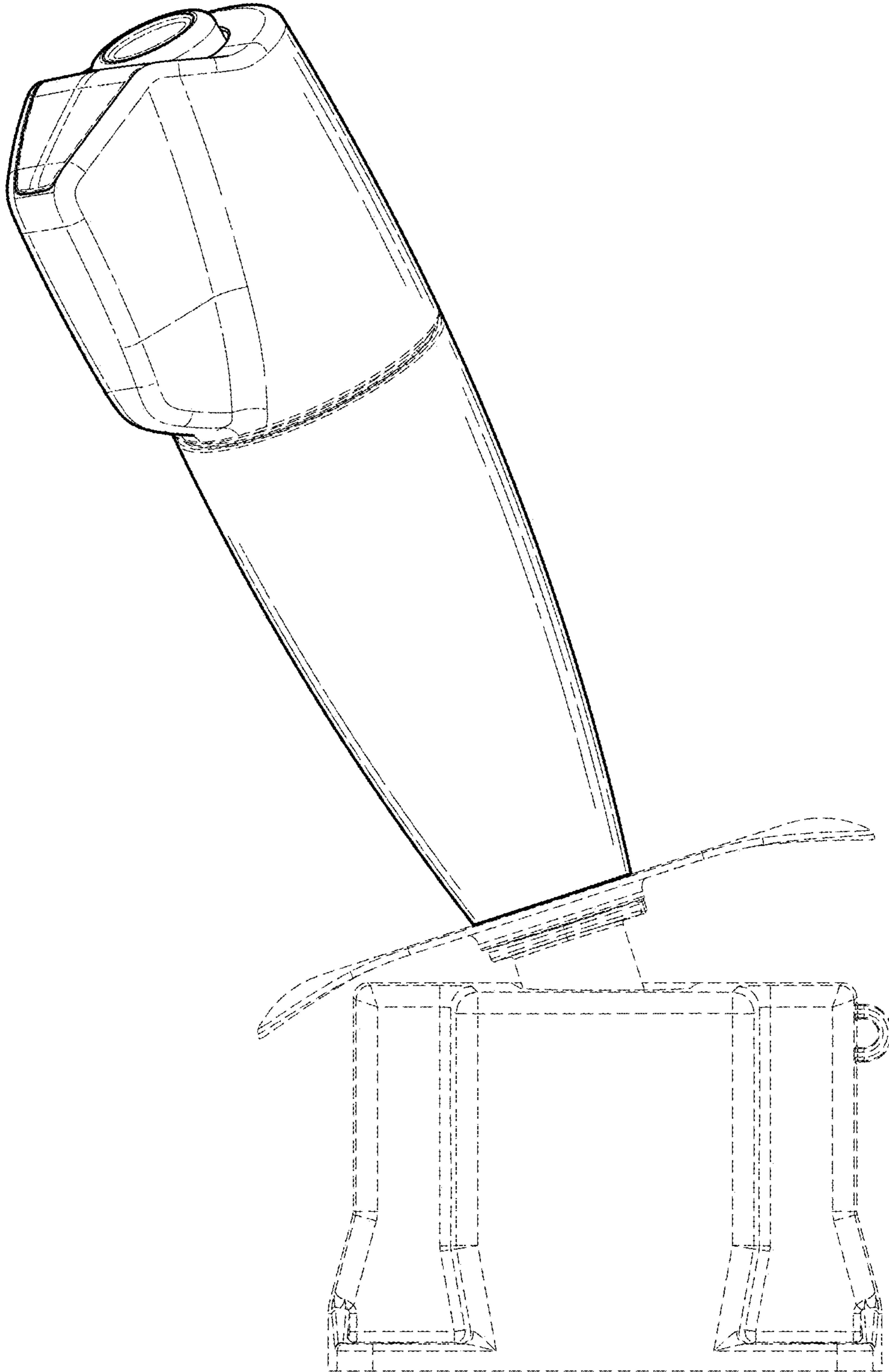

Fig. 23.

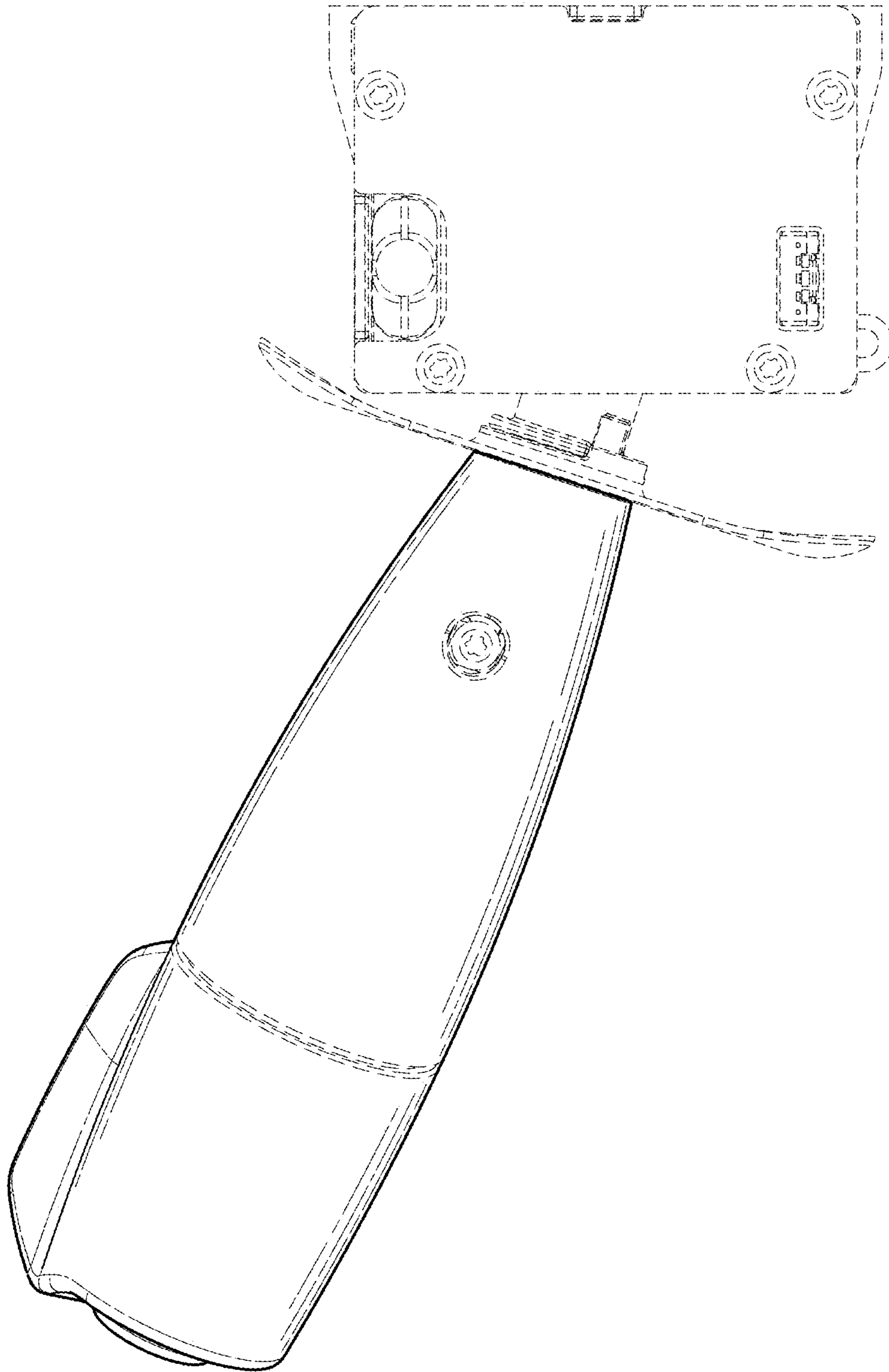

Fig. 24.

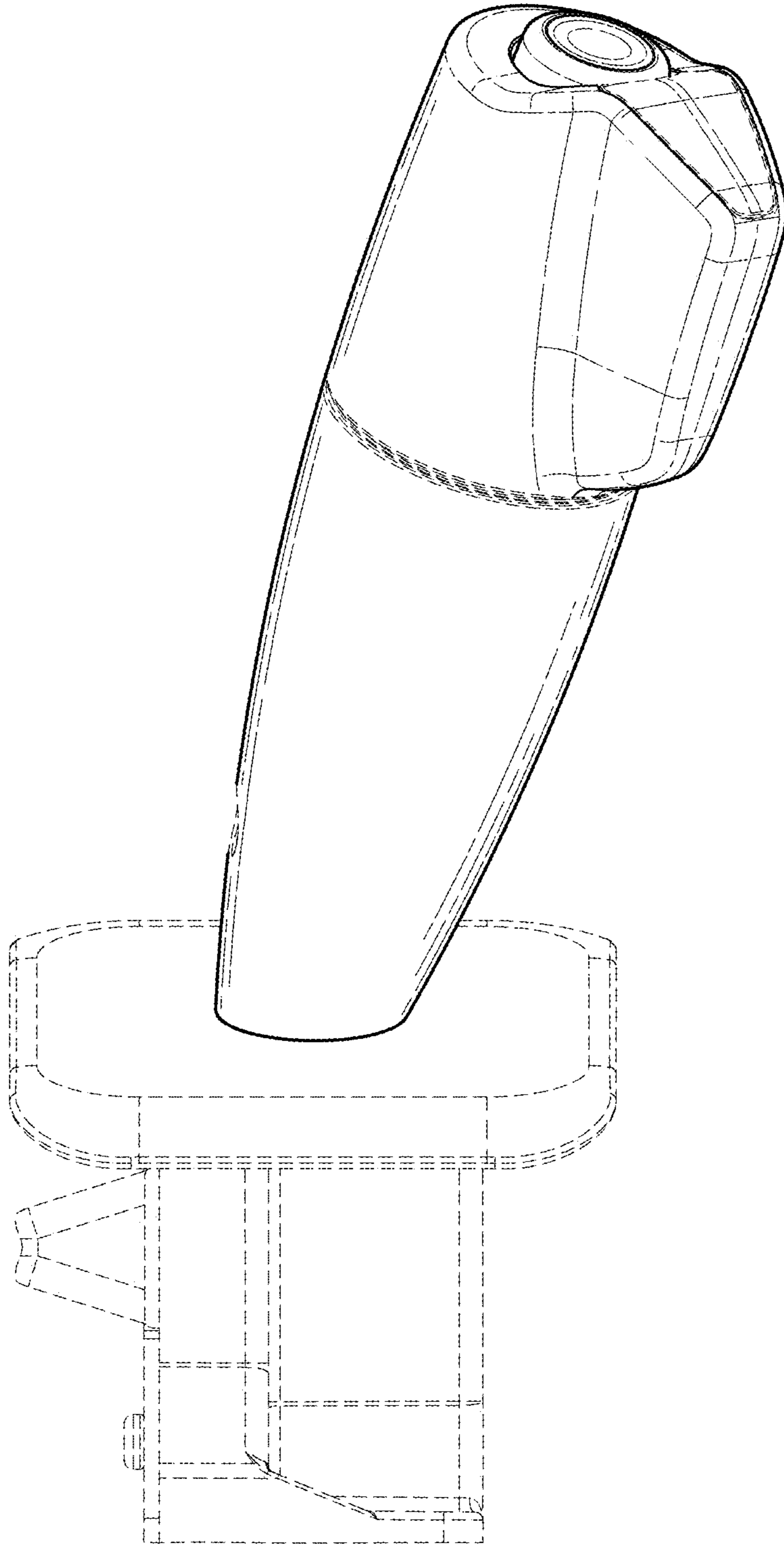

Fig. 25.

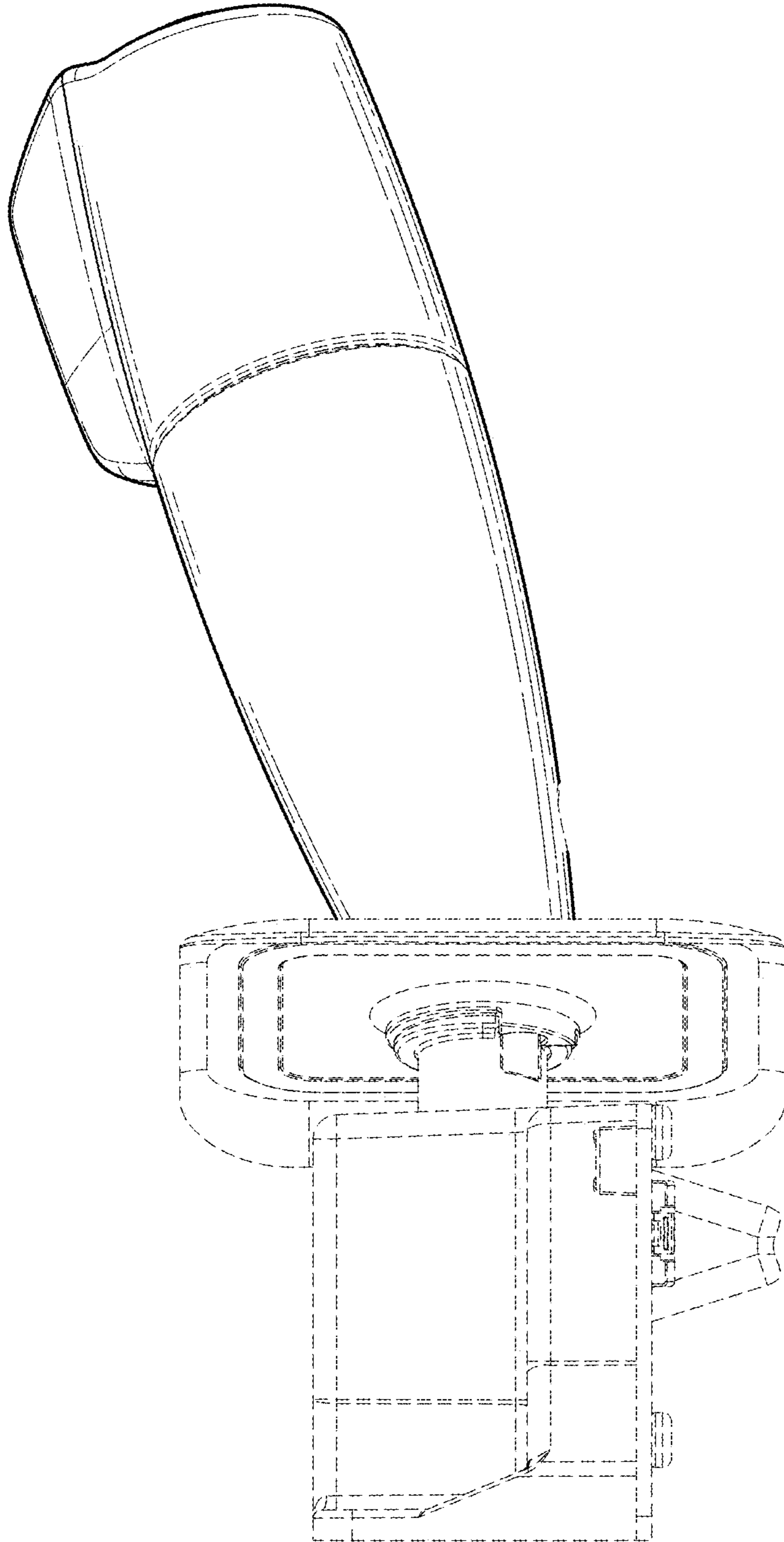

Fig. 26.

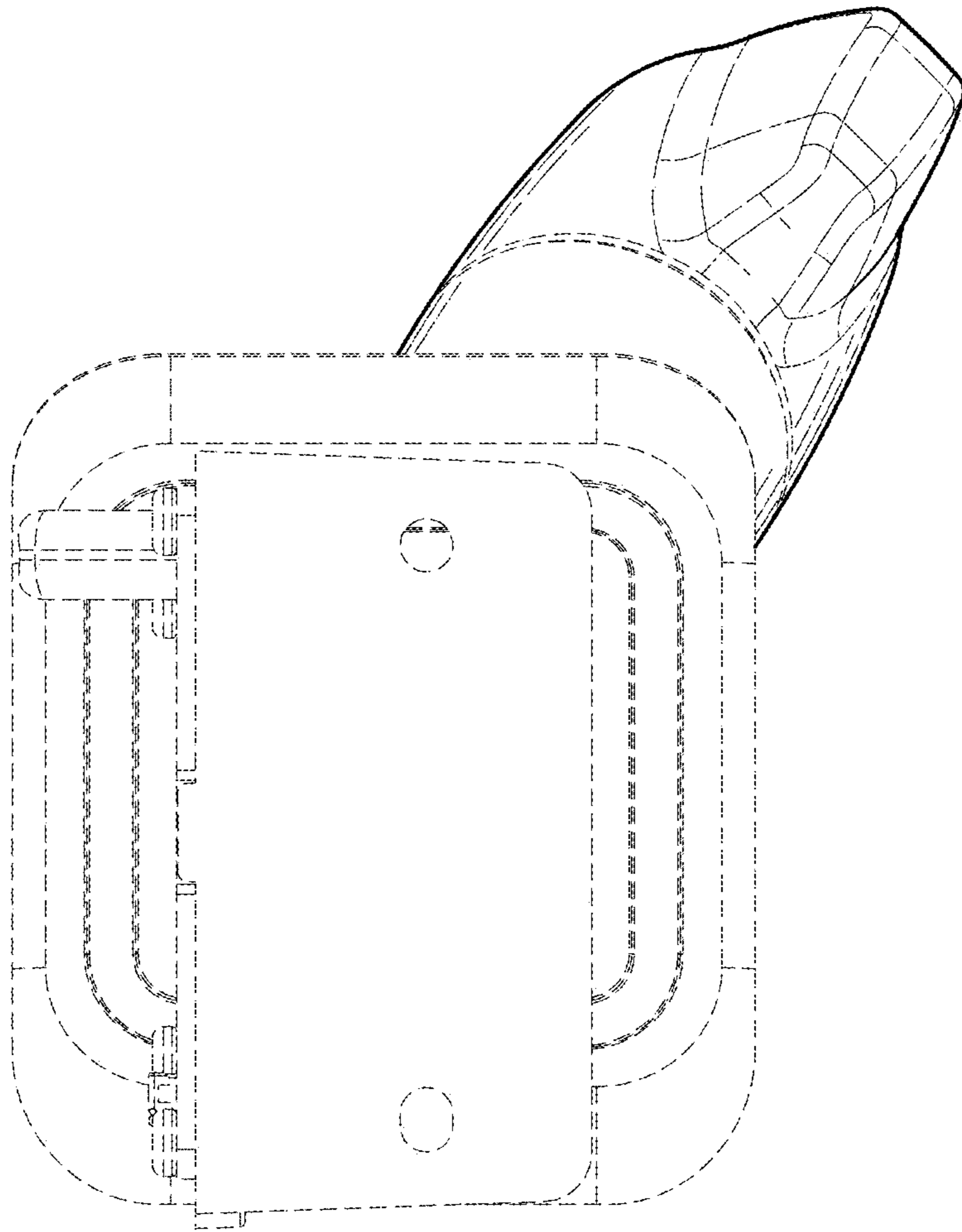

Fig. 27.

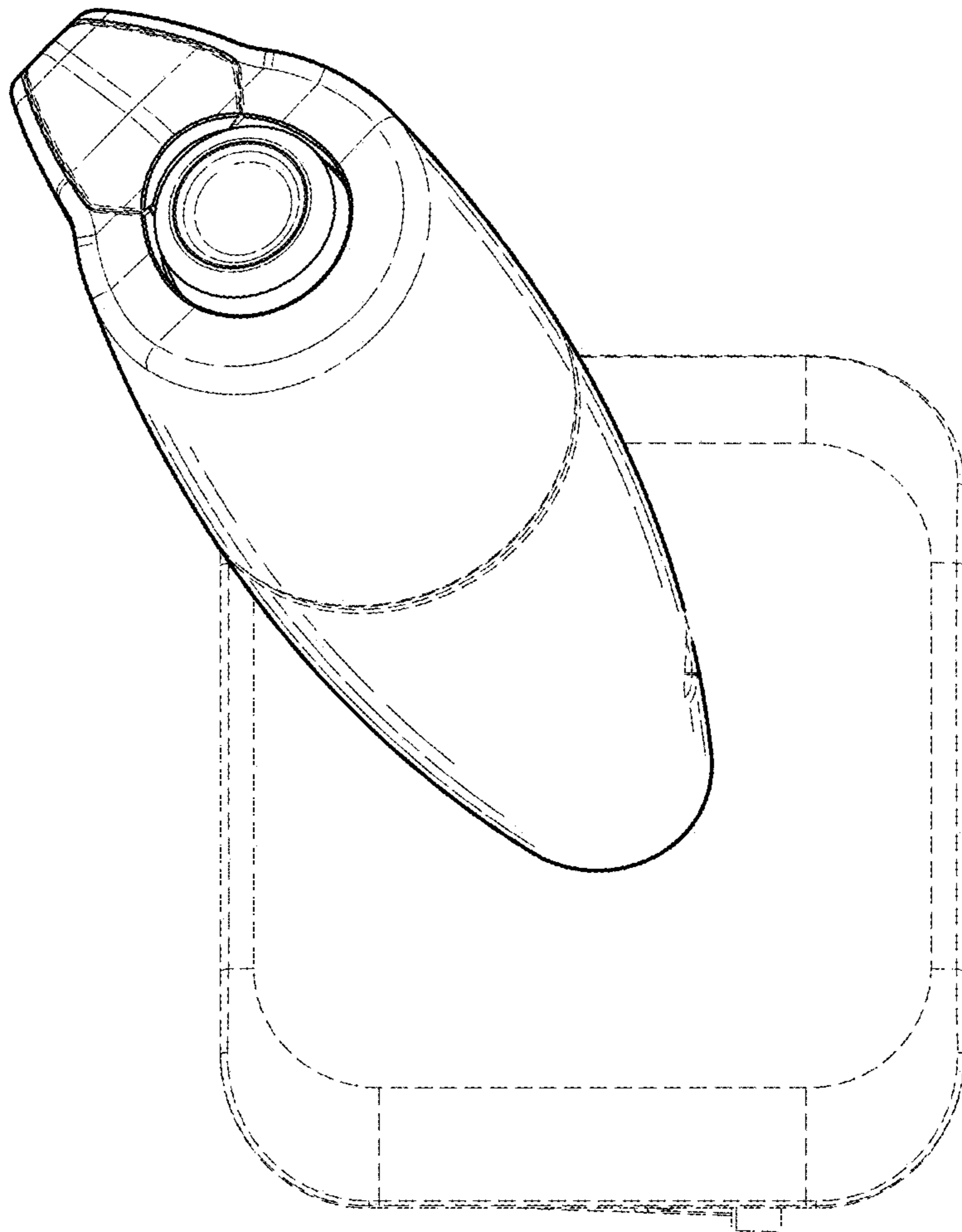

Fig. 28.