



US00D904203S

(12) **United States Design Patent** (10) **Patent No.:** **US D904,203 S**
Bouma et al. (45) **Date of Patent:** **** Dec. 8, 2020**

(54) **PACKAGING WITH FOOD PRODUCT**
(71) Applicants: **Andrea Bouma**, Thomasville, GA
(US); **Dawn Merrill**, Thomasville, GA
(US); **Jay Hodson**, Osh Kosh, WI (US)
(72) Inventors: **Andrea Bouma**, Thomasville, GA
(US); **Dawn Merrill**, Thomasville, GA
(US); **Jay Hodson**, Osh Kosh, WI (US)

(**) Term: **15 Years**

(21) Appl. No.: **29/663,117**

(22) Filed: **Sep. 12, 2018**

(51) **LOC (12) Cl.** **09-03**

(52) **U.S. Cl.**
USPC **D9/720**

(58) **Field of Classification Search**
USPC D9/702, 707, 709, 710, 715, 720, 721
CPC B65D 75/26; B65D 85/76; B65D 75/5855;
B65D 75/30; B65D 65/40; B65D 31/02;
B65D 75/20; B65D 2575/586; B65D
75/12; B32B 2439/70
See application file for complete search history.

(56) **References Cited**

U.S. PATENT DOCUMENTS

- D192,618 S * 4/1962 Bush D9/707
- 3,145,112 A * 8/1964 Boegershausen B65D 75/527
426/121
- D335,255 S * 5/1993 Carrillo D21/709
- D363,670 S * 10/1995 Sullivan D9/707
- D560,492 S * 1/2008 Markowicz D9/721

- D574,259 S * 8/2008 Roskamp D9/720
- D695,992 S * 12/2013 Wyne D1/128
- D853,227 S * 7/2019 Abadinsky D9/415
- 2009/0136627 A1 * 5/2009 Schuman B65B 25/068
426/87
- 2014/0272005 A1 * 9/2014 Thomas B65D 77/062
426/87
- 2016/0221738 A1 * 8/2016 Ball B65D 75/566

* cited by examiner

Primary Examiner — Lauren R Calve
(74) *Attorney, Agent, or Firm* — Kilpatrick Townsend & Stockton LLP

(57) **CLAIM**

The ornamental design for packaging with food product, as shown and described.

DESCRIPTION

FIG. 1 is an isometric view of a packaging with food product.
FIG. 2 is another isometric view thereof.
FIG. 3 is a front view thereof.
FIG. 4 is a rear view thereof.
FIG. 5 is a left side view thereof.
FIG. 6 is a right side view thereof.
FIG. 7 is a top view thereof; and,
FIG. 8 is a bottom view thereof.
The broken lines in the drawings are for illustrative purposes only and form no part of the claimed design. The broken lines showing the logos on the front and back of the packaging form no part of the claimed design. The oblique shading lines denote transparency and the contour of the packaging.

1 Claim, 7 Drawing Sheets

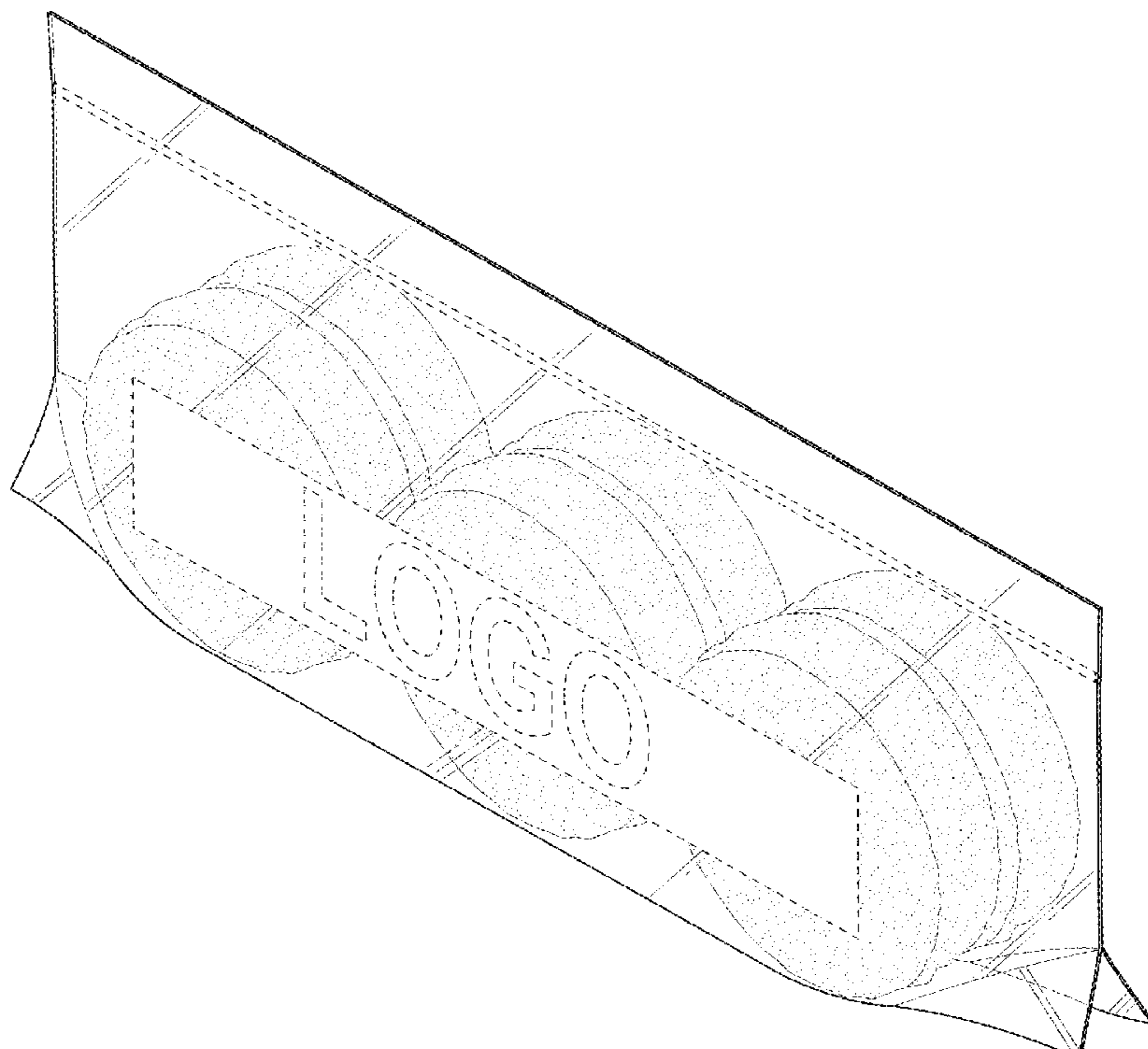

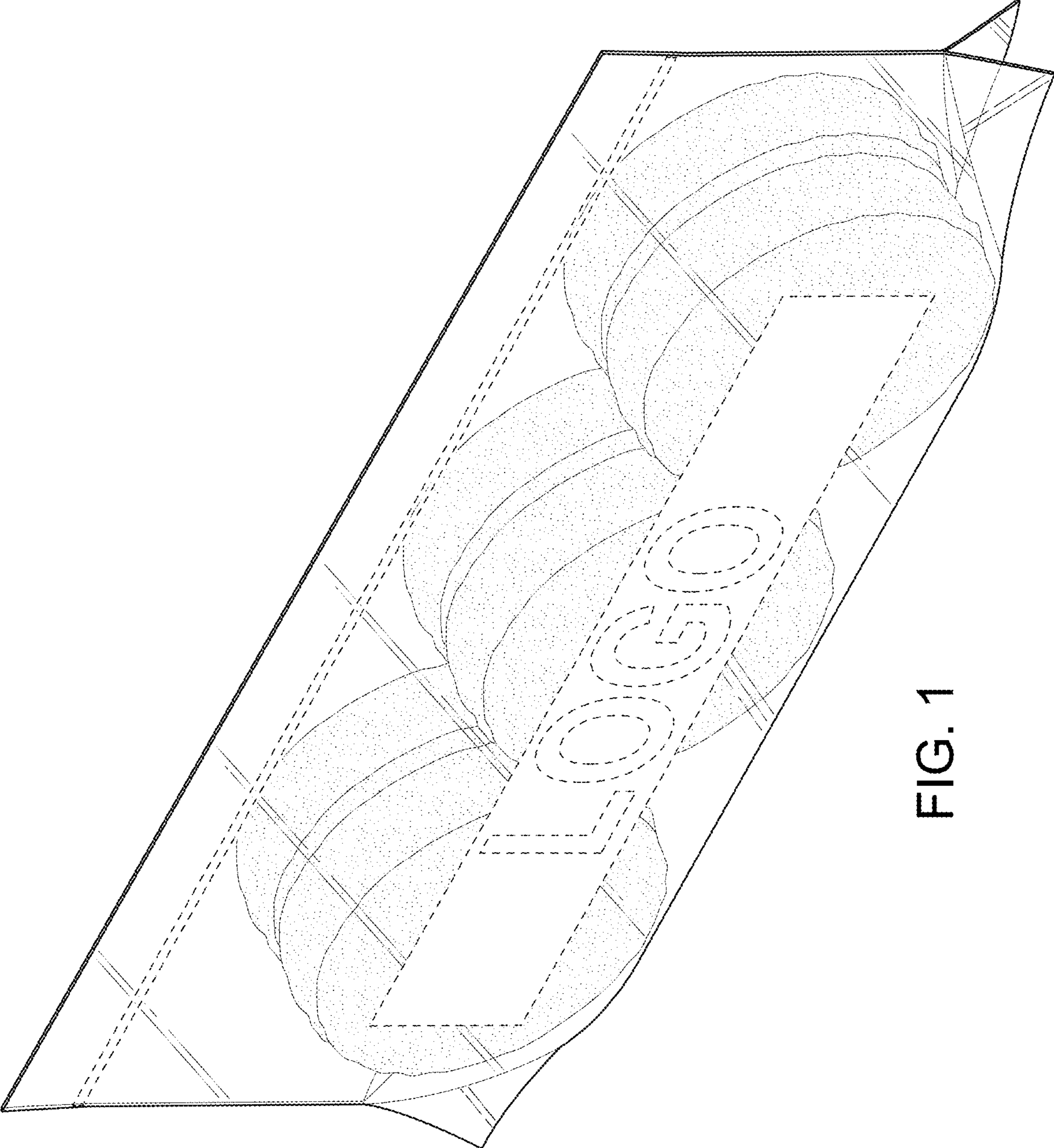

FIG. 1

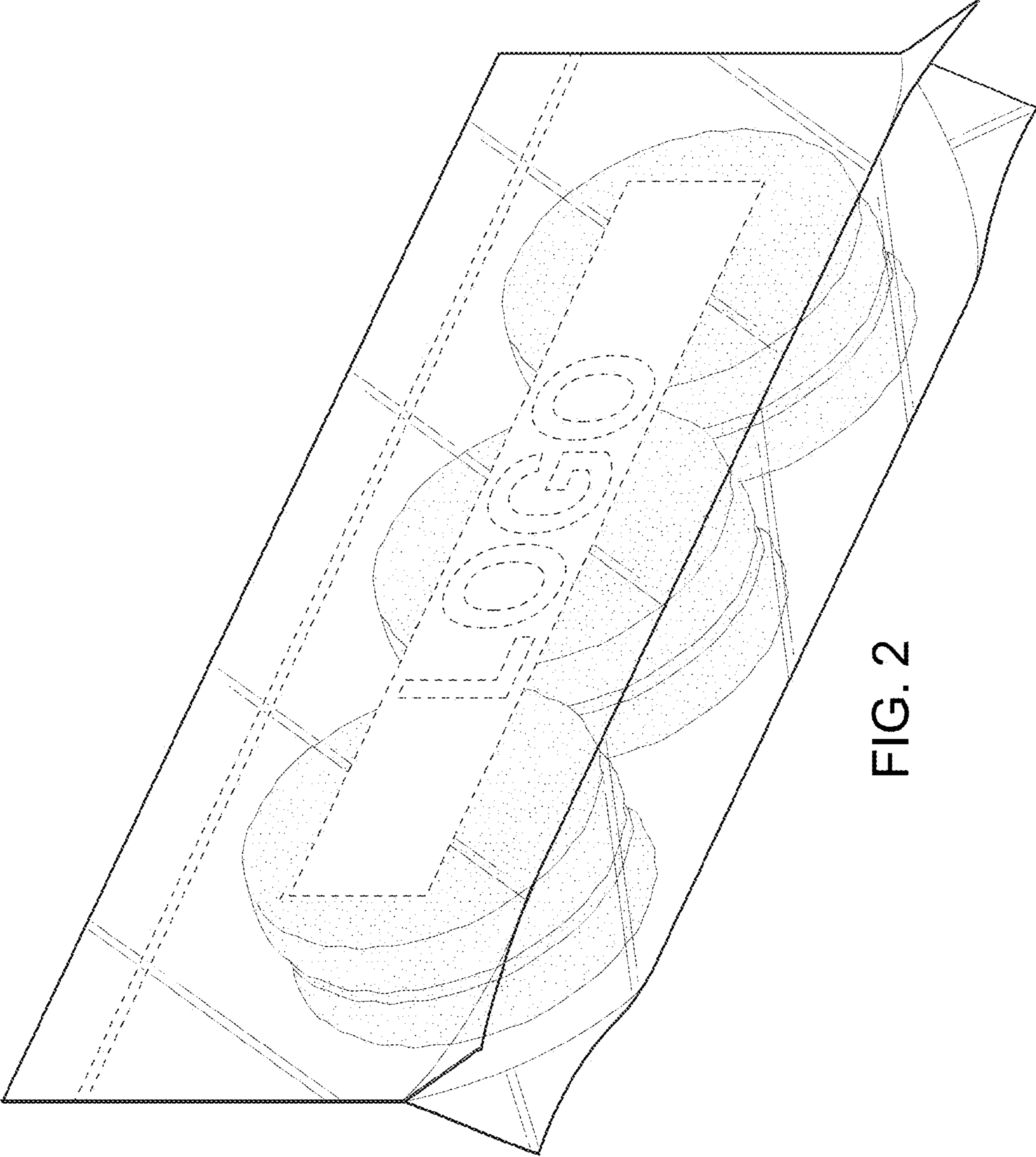

FIG. 2

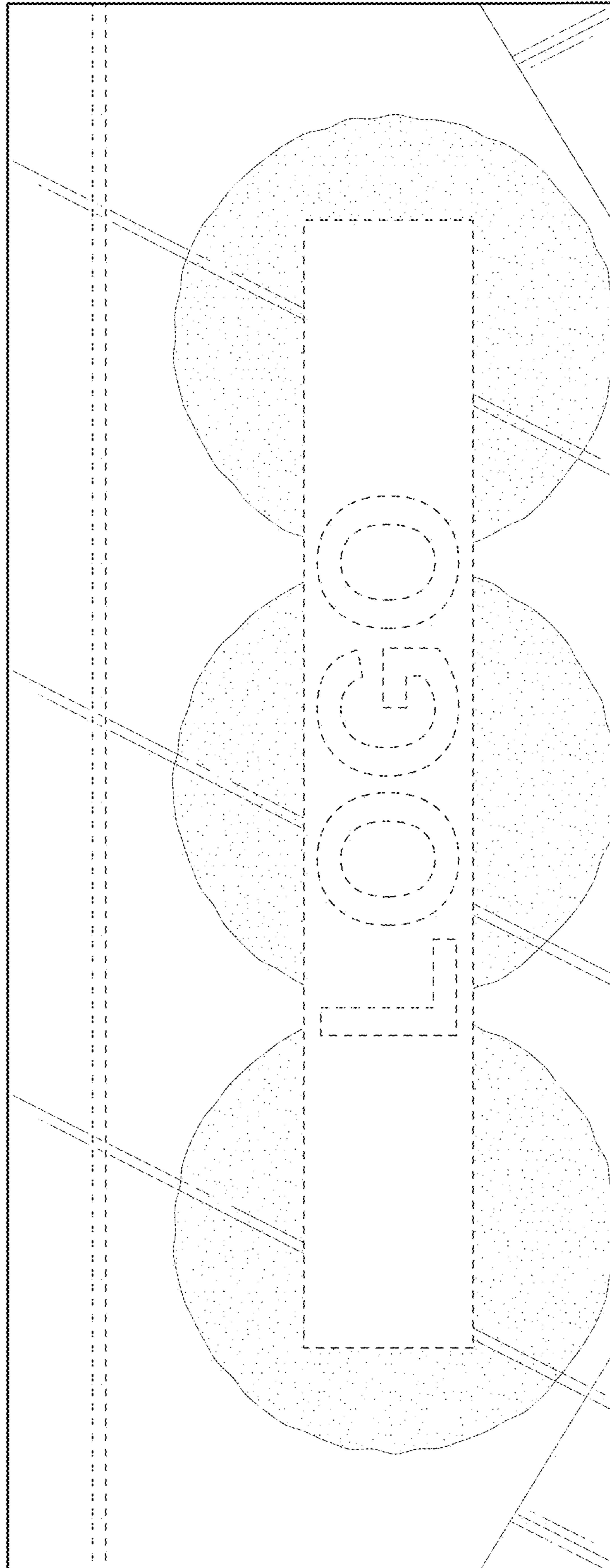

FIG. 3

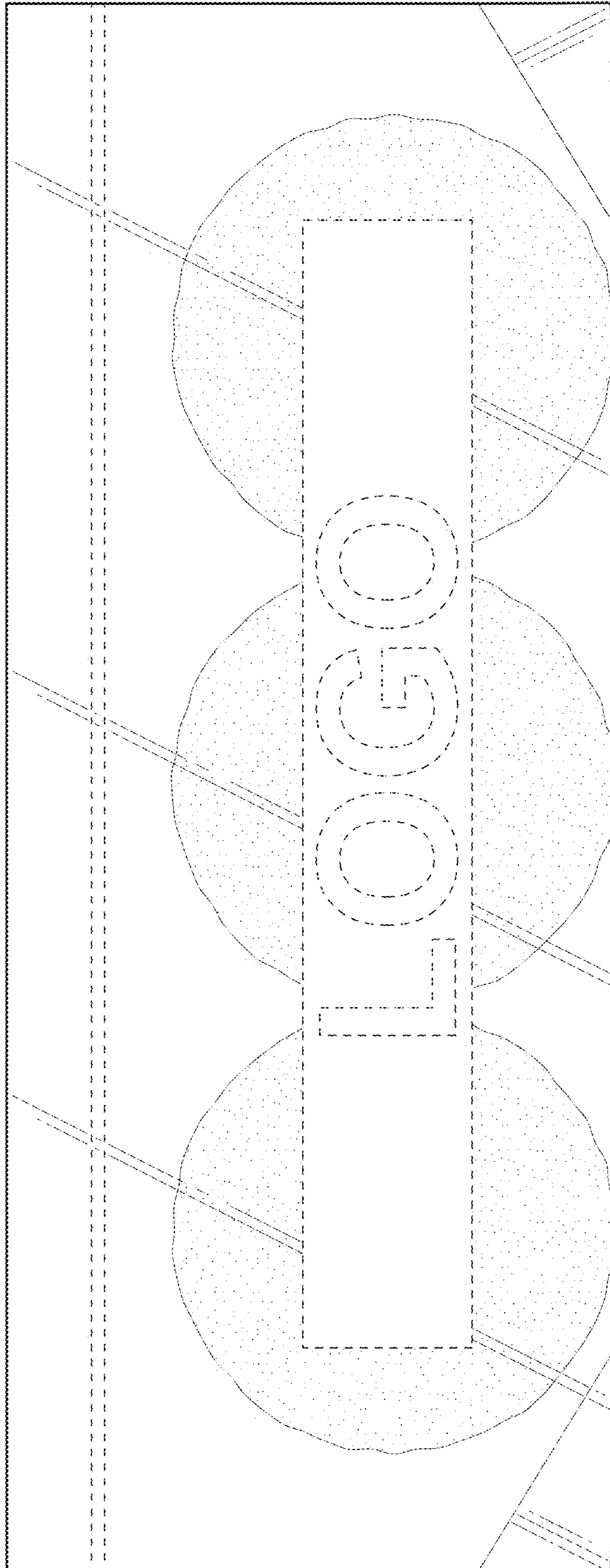

FIG. 4

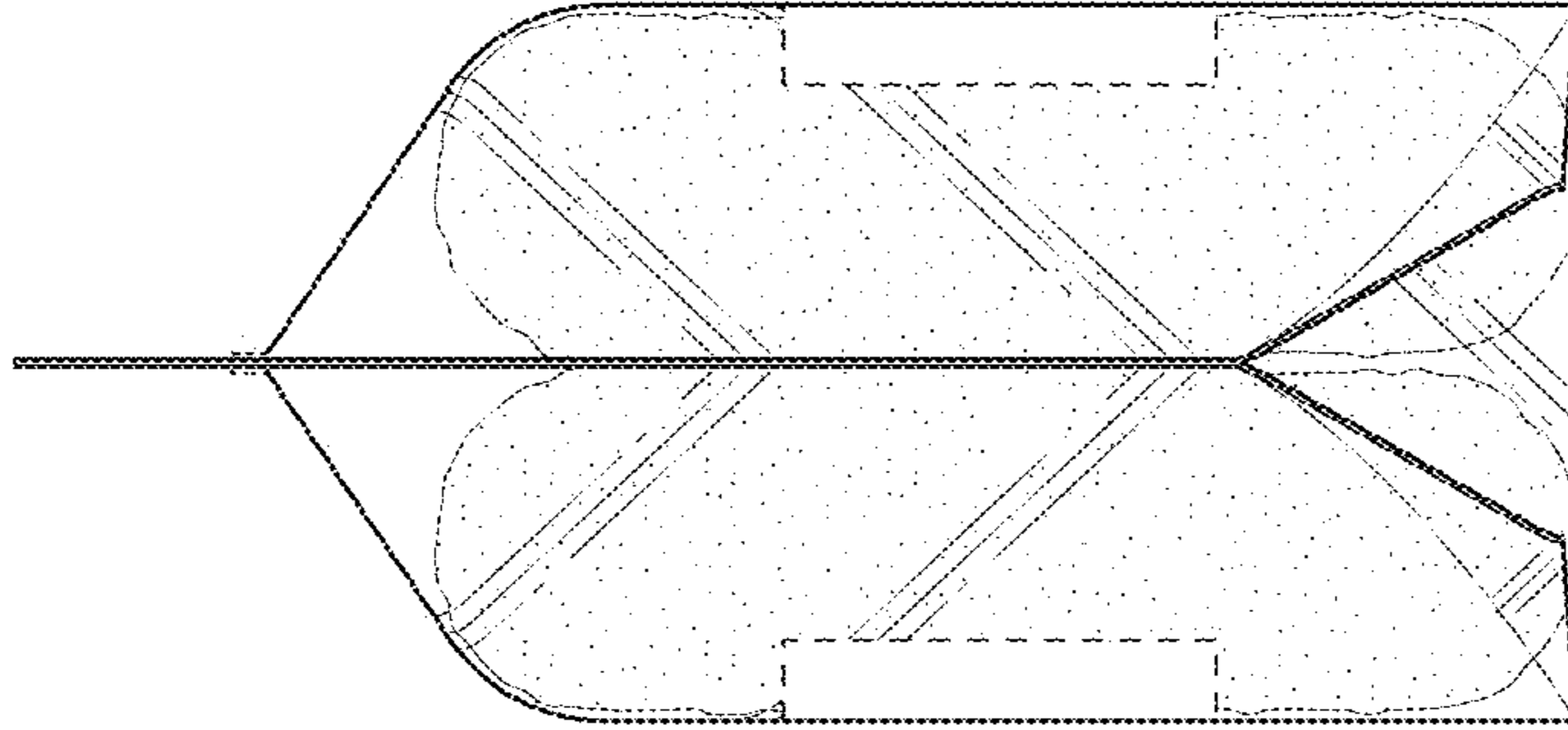

FIG. 5

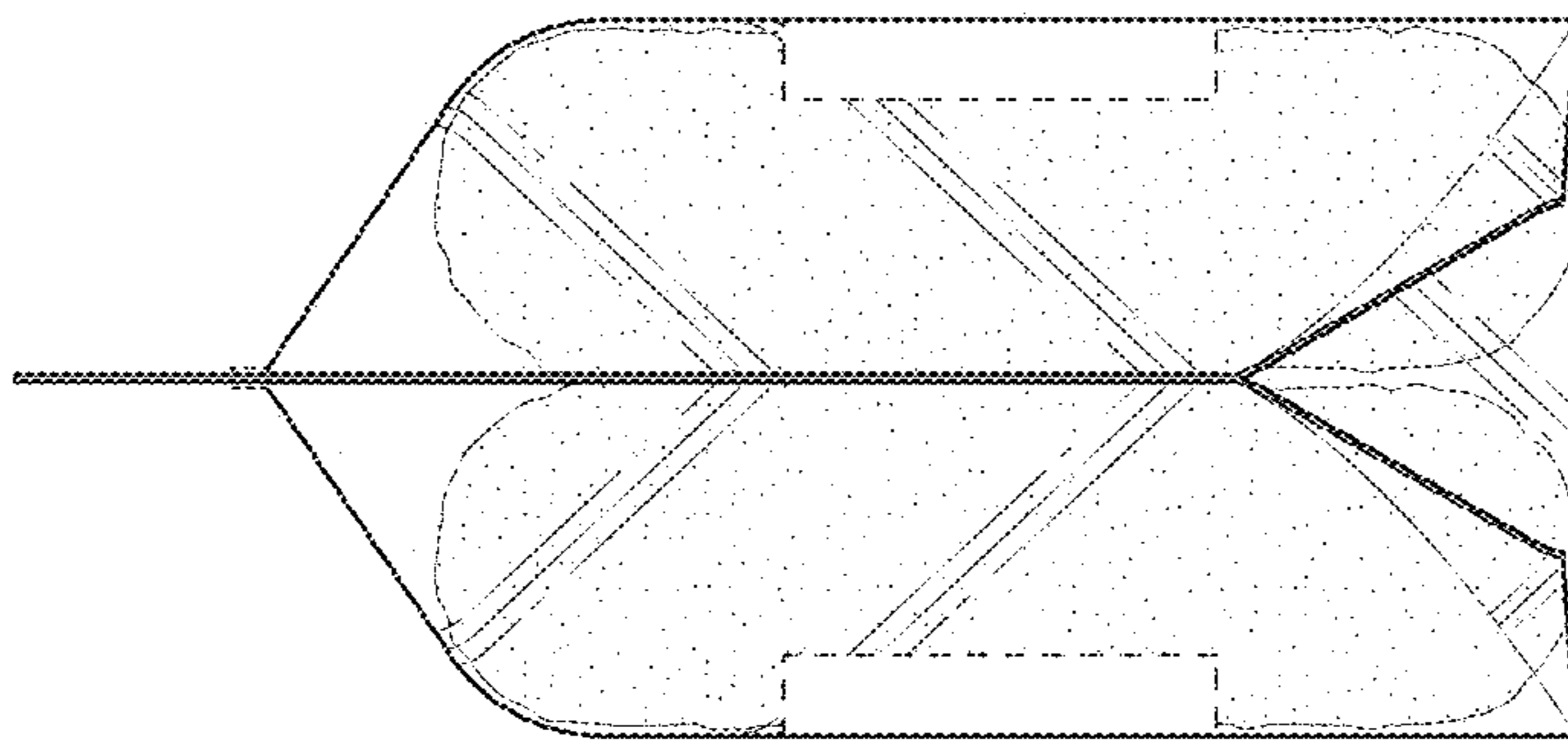

FIG. 6

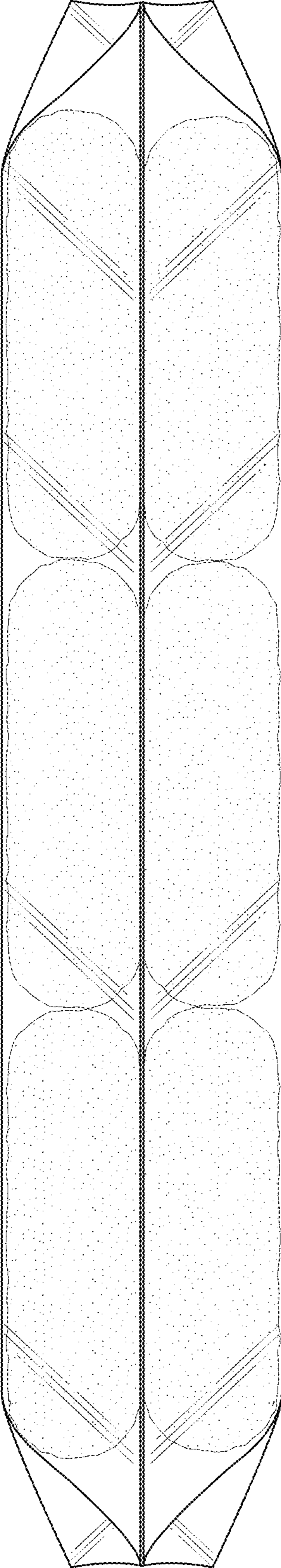

FIG. 7

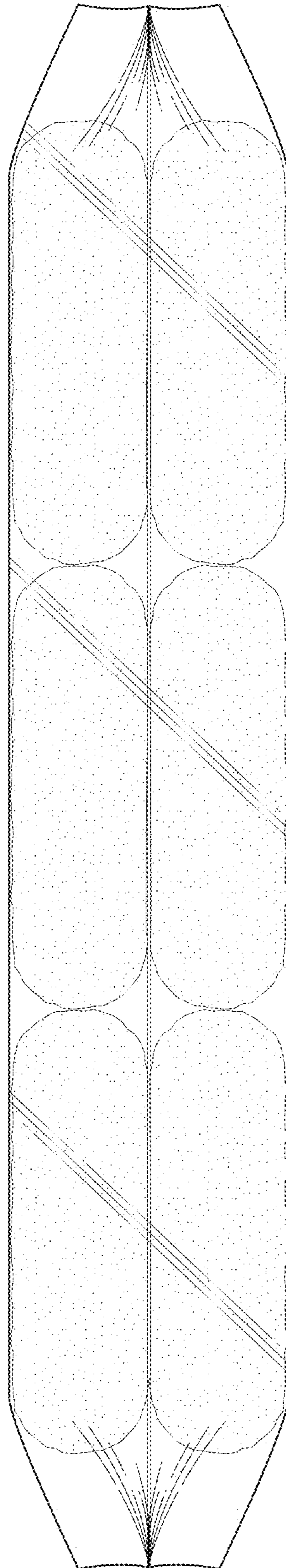

FIG. 8