



US00D904049S

(12) **United States Design Patent** (10) **Patent No.:** **US D904,049 S**
Toll (45) **Date of Patent:** **** Dec. 8, 2020**

(54) **BICYCLE SEAT**

FOREIGN PATENT DOCUMENTS

(71) Applicant: **ISM Saddles, LLC**, Lutz, FL (US)

EP 1444127 11/2004
EP 2910458 8/2015

(72) Inventor: **Steven G. Toll**, Lutz, FL (US)

(Continued)

(73) Assignee: **ISM Saddles, LLC**, Lutz, FL (US)

OTHER PUBLICATIONS

(**) Term: **15 Years**

Leibovitch et al., "The Vicious Cycling: Bicycling Related Uro-genital Disorders", European Urology 47, pp. 277-287 (2005).

(21) Appl. No.: **29/684,664**

(Continued)

(22) Filed: **Mar. 22, 2019**

Primary Examiner — Natasha Vujcic

(51) **LOC (12) Cl.** **06-01**

(74) *Attorney, Agent, or Firm* — Akerman LLP; Peter A. Chiabotti

(52) **U.S. Cl.**

(57) **CLAIM**

USPC **D6/354**

The ornamental design for a bicycle seat, as shown and described.

(58) **Field of Classification Search**

USPC D6/340, 354; D12/110, 111

CPC ... B62J 1/002; B62J 1/005; B62J 1/007; B62J

1/26

DESCRIPTION

See application file for complete search history.

FIG. 1 is a perspective view of a bicycle seat showing my new design.

(56) **References Cited**

U.S. PATENT DOCUMENTS

642,191 A 1/1890 Wright
464,653 A 12/1891 Latta
532,444 A 1/1895 Christy
D24,139 S * 3/1895 Christy D6/354
537,375 A 4/1895 Wright et al.
568,626 A 9/1896 Pierce et al.
570,497 A 11/1896 Pattison
572,062 A 11/1896 Peck
D27,616 S 8/1897 Rusch
D28,433 S 3/1898 Hollenbeck
D28,434 S 3/1898 Hollenbeck
602,732 A 4/1898 Craig
605,151 A 6/1898 Twist
608,682 A 8/1898 Jamieson
612,552 A 10/1898 Standeford
612,972 A 10/1898 Leech

FIG. 2 is a top plan view thereof;

FIG. 3 is a bottom plan view thereof;

FIG. 4 is a left side elevation view thereof;

FIG. 5 is a right side elevation view thereof;

FIG. 6 is a front view thereof;

FIG. 7 is a rear view thereof;

FIG. 8 is a perspective view of the bicycle seat showing my new design in accordance with an alternative embodiment;

FIG. 9 is a top plan view thereof;

FIG. 10 is a bottom plan view thereof;

FIG. 11 is a left side elevation view thereof;

FIG. 12 is a right side elevation view thereof;

FIG. 13 is a front view thereof; and,

FIG. 14 is a rear view thereof.

The broken lines in the drawings illustrate portions of the bicycle seat which form no part of the claimed design.

(Continued)

1 Claim, 10 Drawing Sheets

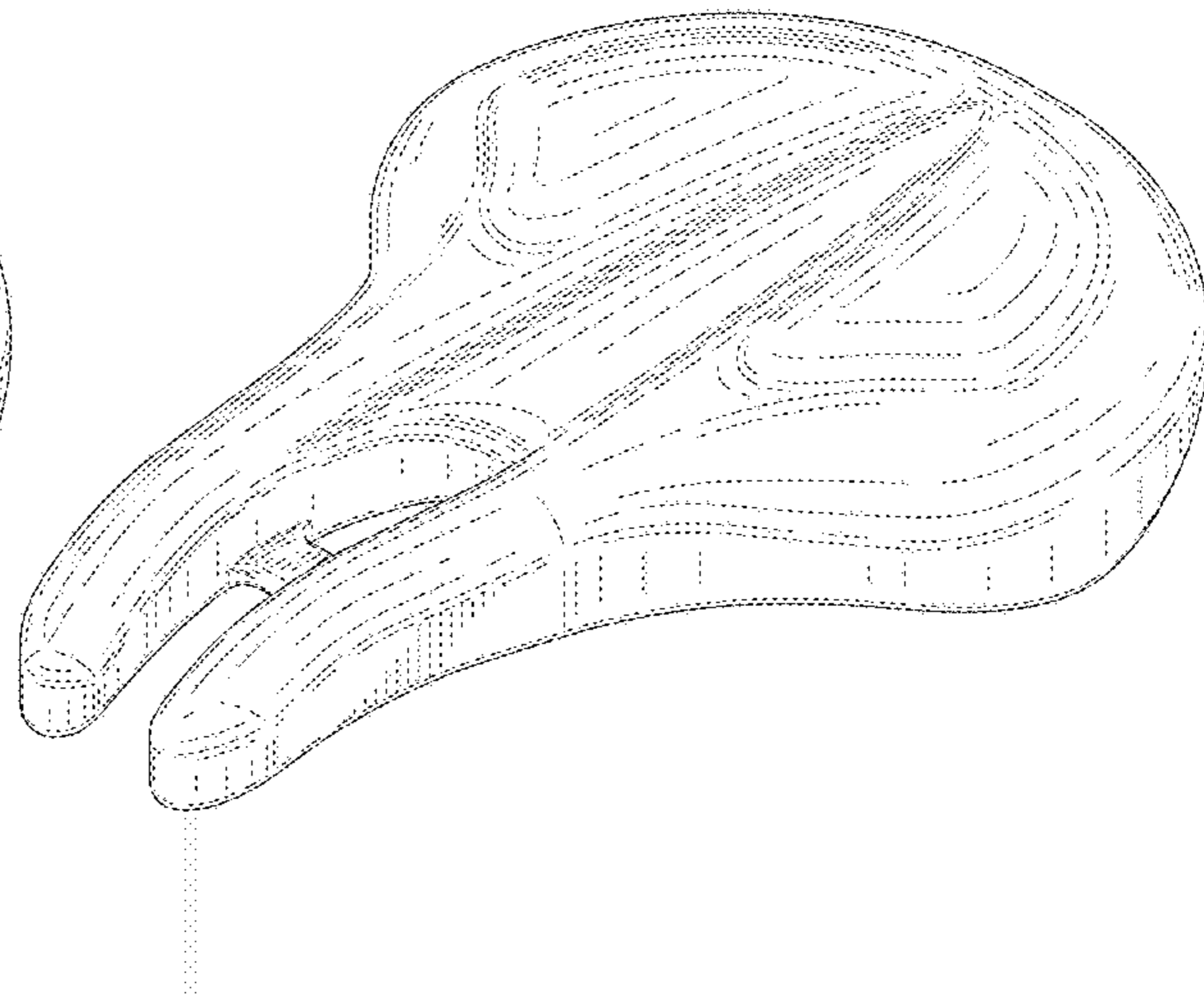
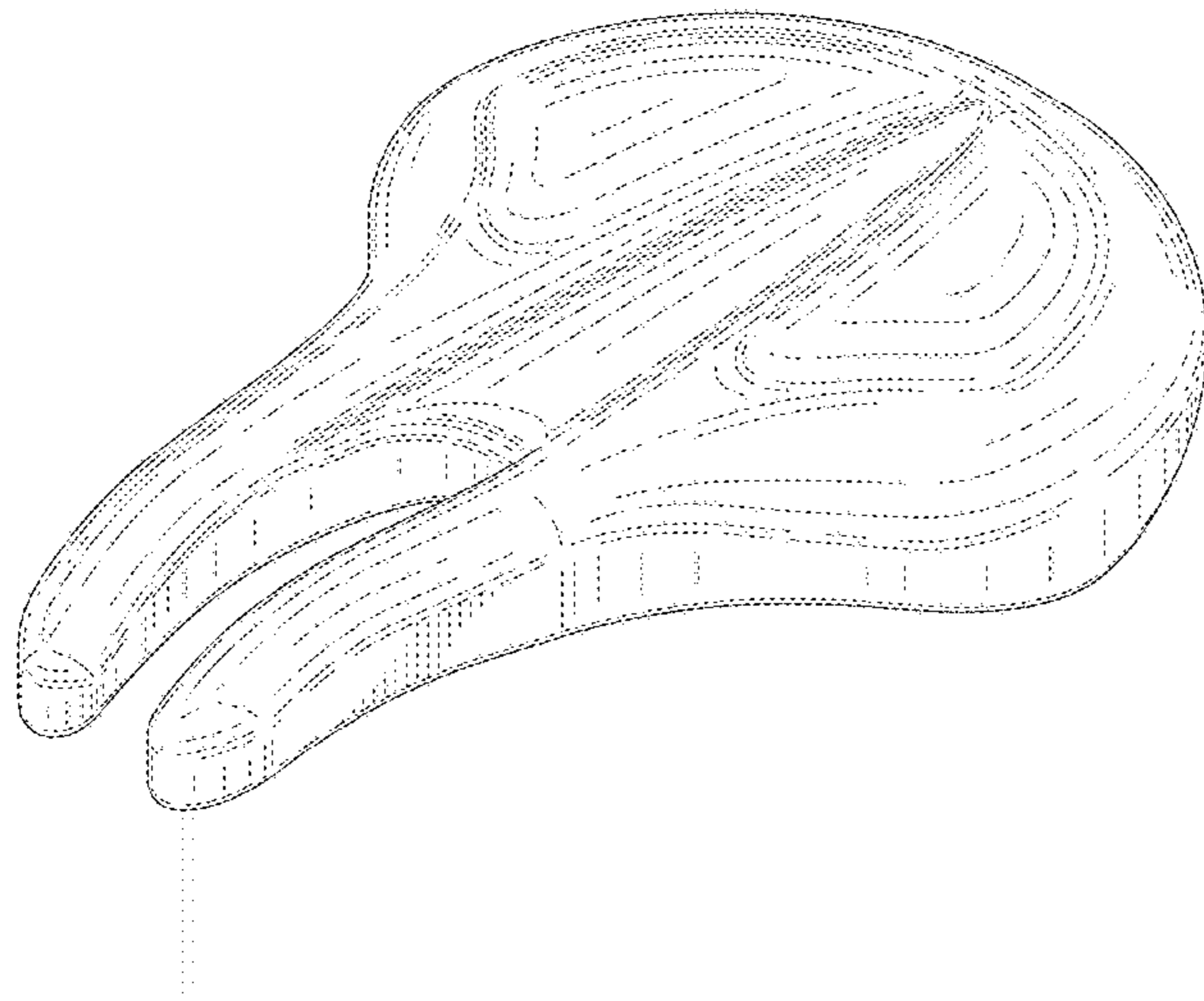

(56)

References Cited

U.S. PATENT DOCUMENTS

| | | | | | |
|--------------|---------|----------------------|-----------------|---------|----------------------|
| D29,719 S | 11/1898 | Leech et al. | D575,070 S | 8/2008 | Toll |
| 619,204 A | 2/1899 | Moore | 7,441,836 B2 | 10/2008 | Chen et al. |
| 622,357 A | 4/1899 | Hitchcock et al. | 7,478,871 B2 | 1/2009 | Pandozy |
| 623,238 A | 4/1899 | Davis | D590,160 S | 4/2009 | Hung |
| 629,956 A | 8/1899 | Craig | 7,537,281 B2 | 5/2009 | Riondato |
| 635,598 A | 10/1899 | Rowe | D604,056 S | 11/2009 | Toll et al. |
| 654,720 A | 7/1900 | Englebert | D604,057 S | 11/2009 | Toll |
| 701,390 A | 6/1902 | Provoost | 7,699,391 B2 | 4/2010 | Riondato |
| 872,124 A | 11/1907 | Hammaren | D622,973 S | 9/2010 | Toll |
| 1,462,976 A | 9/1922 | Mesinger | 7,934,770 B2 | 5/2011 | Toll |
| 1,538,542 A | 2/1924 | Blake | D639,081 S | 6/2011 | Toll |
| 1,858,477 A | 5/1932 | Blake | D640,879 S | 7/2011 | Curran |
| D106,117 S | 5/1937 | Kraeft | 7,976,102 B2 | 7/2011 | Chang |
| D213,488 S | 3/1969 | Golden | D642,846 S | 8/2011 | Parish et al. |
| 3,844,611 A | 10/1974 | Young | D658,396 S | 5/2012 | Sprouse, II |
| D237,123 S | 10/1975 | Hogkvist | D677,479 S | 3/2013 | Toll |
| 4,429,915 A | 2/1984 | Flager | D684,780 S | 6/2013 | Toll |
| 4,451,083 A | 5/1984 | Marchello | D684,781 S | 6/2013 | Toll |
| 4,898,422 A | 2/1990 | West | 8,480,169 B2 | 7/2013 | Bailie et al. |
| D306,378 S | 3/1990 | Bernardi | D688,051 S | 8/2013 | Toll |
| D315,646 S | 3/1991 | Hood | D688,052 S | 8/2013 | Toll |
| 4,999,068 A | 3/1991 | Chiarella | D688,477 S | 8/2013 | Toll |
| 5,011,222 A | 4/1991 | Yates et al. | D688,478 S | 8/2013 | Toll |
| 5,108,076 A | 4/1992 | Chiarella | D688,479 S | 8/2013 | Toll |
| 5,167,435 A | 12/1992 | Aldi | 8,845,018 B2 | 9/2014 | Toll |
| 5,676,420 A | 10/1997 | Kuipers et al. | D720,548 S * | 1/2015 | Yu D6/354 |
| 5,765,912 A | 6/1998 | Bontrager | D720,939 S | 1/2015 | Toll |
| 5,863,094 A | 1/1999 | Endo | D722,446 S | 2/2015 | Toll |
| 5,873,626 A | 2/1999 | Katz | D724,329 S | 3/2015 | Toll |
| D407,910 S | 4/1999 | Terry | D724,330 S | 3/2015 | Toll |
| D408,159 S | 4/1999 | Clutton | D753,925 S | 4/2016 | Toll |
| D409,009 S | 5/1999 | Toll et al. | D753,926 S | 4/2016 | Smith et al. |
| D412,791 S | 8/1999 | Tsai | D754,450 S | 4/2016 | Toll |
| D416,394 S | 11/1999 | Minkow et al. | D756,675 S | 5/2016 | Toll |
| D417,560 S | 12/1999 | Tollefson et al. | D760,507 S * | 7/2016 | Marcel D6/354 |
| 6,019,423 A | 1/2000 | Dodge et al. | D762,073 S | 7/2016 | Toll |
| 6,039,395 A | 3/2000 | Culbertson | D764,820 S | 8/2016 | Toll |
| D428,270 S | 7/2000 | Bigolin | D764,821 S | 8/2016 | Toll |
| D428,271 S | 7/2000 | Bigolin | D764,822 S | 8/2016 | Toll |
| D429,905 S | 8/2000 | White | D767,909 S | 10/2016 | Toll |
| D430,744 S | 9/2000 | Minkow et al. | D767,910 S | 10/2016 | Toll |
| D430,745 S | 9/2000 | Minkow et al. | D767,911 S | 10/2016 | Toll |
| 6,113,184 A | 9/2000 | Barnes | D769,007 S | 10/2016 | Toll |
| 6,139,098 A | 10/2000 | Carrillo | D769,008 S | 10/2016 | Toll |
| D433,827 S | 11/2000 | Kulpers | D769,631 S | 10/2016 | Toll |
| D434,235 S | 11/2000 | Kulpers | D774,790 S | 12/2016 | Toll |
| 6,193,309 B1 | 2/2001 | Gootter et al. | D774,791 S | 12/2016 | Toll |
| D439,756 S * | 4/2001 | Bigolin D6/354 | D778,079 S | 2/2017 | Porter et al. |
| D440,779 S | 4/2001 | Bernardi | D784,033 S | 4/2017 | Li |
| 6,224,151 B1 | 5/2001 | McMullen | D786,573 S | 5/2017 | Toll |
| D443,426 S | 6/2001 | Diaz | 9,718,509 B2 | 8/2017 | Toll |
| 6,244,655 B1 | 6/2001 | Minkow et al. | D802,947 S | 11/2017 | Toll |
| D446,032 S | 8/2001 | Arcieri | D802,948 S | 11/2017 | Toll |
| 6,290,291 B1 | 9/2001 | Kojima | D802,949 S | 11/2017 | Toll |
| D453,881 S * | 2/2002 | Chuang D6/354 | D803,594 S | 11/2017 | Toll |
| D454,258 S | 3/2002 | Yates | D804,204 S | 12/2017 | Bigolin et al. |
| D456,157 S | 4/2002 | Yates | D806,415 S | 1/2018 | Toll |
| D456,623 S * | 5/2002 | Yates D6/354 | D809,810 S | 2/2018 | Pizarro |
| 6,402,236 B1 | 6/2002 | Yates | D846,896 S * | 4/2019 | Hain D6/354 |
| 6,422,647 B1 | 7/2002 | Turudich | D846,897 S | 4/2019 | Toll |
| 6,450,572 B1 | 9/2002 | Kuipers | D846,899 S | 4/2019 | Toll |
| D463,676 S | 10/2002 | Minkow et al. | D846,900 S | 4/2019 | Toll |
| 6,652,025 B2 | 11/2003 | Sylvester | D847,522 S | 5/2019 | Pruitt et al. |
| 6,669,283 B2 | 12/2003 | Yu | 10,358,181 B2 | 7/2019 | Toll |
| 6,761,400 B2 | 7/2004 | Hobson | D856,013 S | 8/2019 | Jalkanen |
| 6,783,176 B2 | 8/2004 | Ladson, III | D856,014 S | 8/2019 | Jalkanen |
| 6,880,885 B2 | 4/2005 | Lan | D875,411 S * | 2/2020 | Bigolin D6/354 |
| D507,421 S | 7/2005 | Lawson | D879,488 S * | 3/2020 | Liu D6/354 |
| 6,957,857 B1 | 10/2005 | Lee | D880,880 S * | 4/2020 | Toll D6/354 |
| 7,025,417 B2 | 4/2006 | Cohen | D887,731 S * | 6/2020 | Kim D6/354 |
| D523,651 S | 6/2006 | Chao et al. | D889,862 S * | 7/2020 | Toll D6/354 |
| 7,077,469 B2 | 7/2006 | Farré | 2002/0117880 A1 | 8/2002 | Ladson |
| 7,104,600 B2 | 9/2006 | Scholz | 2003/0025363 A1 | 2/2003 | Gaggiola |
| 7,121,622 B1 | 10/2006 | Mendez | 2003/0034678 A1 | 2/2003 | Farré |
| 7,374,517 B2 | 5/2008 | Lockett | 2003/0038515 A1 | 2/2003 | Martin et al. |
| | | | 2003/0067195 A1 | 4/2003 | Sylvester |
| | | | 2003/0071498 A1 | 4/2003 | Yu |
| | | | 2005/0006932 A1 | 1/2005 | Laidlaw |
| | | | 2007/0069557 A1 | 3/2007 | Toll |

(56)

References Cited

U.S. PATENT DOCUMENTS

| | | | |
|--------------|----|---------|-----------|
| 2007/0102970 | A1 | 5/2007 | Wallace |
| 2007/0200399 | A1 | 8/2007 | Riondato |
| 2007/0246978 | A1 | 10/2007 | Yu |
| 2007/0273184 | A1 | 11/2007 | Garneau |
| 2008/0265636 | A1 | 10/2008 | Toll |
| 2009/0079237 | A1 | 3/2009 | Riondato |
| 2010/0109392 | A1 | 5/2010 | Toll |
| 2011/0298253 | A1 | 12/2011 | Toll |
| 2012/0086246 | A1 | 4/2012 | Belliveau |
| 2015/0097401 | A1 | 4/2015 | Toll |
| 2015/0239515 | A1 | 8/2015 | Toll |

FOREIGN PATENT DOCUMENTS

| | | |
|----|-------------|--------|
| FR | 796997 | 4/1936 |
| JP | 2007-186075 | 7/2007 |
| JP | 2008-509047 | 3/2008 |
| JP | 2011-143734 | 7/2011 |
| JP | 2012-162255 | 8/2012 |
| WO | 99/14103 | 3/1999 |
| WO | 2006015731 | 2/2006 |
| WO | 2007/038692 | 4/2007 |
| WO | 2014/035972 | 2/2011 |
| WO | 2013/134253 | 9/2013 |

OTHER PUBLICATIONS

Randrup et al., “Bicycle Riding as a Cause for Erectile Dysfunction”, [www. medicalsexuality.org](http://www.medicalsexuality.org), pp. 26-27, (Nov. 2000).

Jeong et al., “Bicycle Saddle Shape affects penile blood flow”, *International Journal of Impotence Research*, 14, 513-517 (2002).

Spears et al., “The Effect of Saddle Design on Stresses in the Perineum during Cycling”, *Medical Science Sports Exercise*, vol. 35, No. 9, pp. 1620-1625 (2003).

Bressel et al., “Bicycle Seat Designs and Their Effect on Pelvic Angle, Trunk Angle, and Comfort”, *Medical Science Sports Exercise*, vol. 35, No. 2, pp. 327-332 (2003).

Breda et al., and Adara Caruso, M.D., “Development of New Geometric Bicycle Saddle for the Maintenance of Genital—Perineal Vascular Perfusion,” *Journal of Sexual Medicine*, vol. 2, Issue 5, pp. 605-611 (Sep. 2005).

Lowe et al., “Effect of Bicycle Saddle Designs on the Pressure to the Perineum of the Bicyclist”, *Medical Science Sports Exercise*, vol. 36, No. 6, pp. 1055-1062 (2004).

Bressel et al., “Bicycle Seat Interface Pressure: Reliability, Validity, and Influence of Hand Position and Workload”, *Journal of Biomechanics*, vol. 38, Issue 6, pp. 1325-1331 (Jun. 2005).

Bressel et al., “Influence of Bicycle Seat Pressure on compression of the perineum: a MRI Analysis,” *Journal of Biomechanics* 40, pp. 198-202 (2007, Accepted Nov. 26, 2005).

U.S. Appl. No. 29/539,809, filed Jul. 21, 2016 with the following characterization: “Noseless Saddles—My Two Cents Worth.” *The Bike Noob.*, Jun. 30, 2011 [online], [retrieved on Jul. 8, 2016]. Retrieved from the Internet <URL: <http://bikenooob.com/2011/06/30/noseless-saddles-my-two-cents-worth/>>.

U.S. Appl. No. 29/539,809, filed Jul. 21, 2016 with the following characterization: “Saddles Part 3—ISM Adamo.” *Bike Test Reviews.* Apr. 5, 2013 [online], [retrieved on Jul. 8, 2016]. Retrieved from the Internet <URL: <http://biketestreviews.com/saddles-part-3-ism-adamo/>>.

U.S. Appl. No. 29/484,042, filed Jul. 29, 2014 with the following characterization: “Podium Imports ISM Saddles.” *Podium Imports.*, Feb. 20, 2013 [online], [retrieved on Jul. 19, 2014]. Retrieved from the Internet <URL: <http://www.podiumimports.ca/shop-online/brand/ism-saddles/>>.

U.S. Appl. No. 29/484,042, filed Jul. 29, 2014 with the following characterization: Alter, Lloyd. “No—Nose Bicycle Seats: Are They The Answer to Erectile Dysfunction and Prostate . . .” *Tree Hugger.*, Sep. 17, 2010 [online], [retrieved on Jul. 19, 2014]. Retrieved from the Internet <URL: <http://www.treehugger.com/bikes/no-nose-bicycle-seats-are-they-the-answer-to-erectile-dysfunction-and-prostate-problems-among-cyclists.html>>.

U.S. Appl. No. 29/484,039, filed Jul. 29, 2014 with the following characterization: Demerly, Tom. “ISM Adamo Time Trial and Racing 2 Saddles: The Triathlon Saddle Evolved . . .” *Just Tri Talk.*, Feb. 27, 2013 [online], [retrieved on Jul. 19, 2014]. Retrieved from the Internet <URL: <http://justtritalk.com/ism-adamo-time-trial-and-racing-2-saddles-the-triathlon-saddle-evolved/>>.

U.S. Appl. No. 29/539,813, filed Jul. 25, 2016 with the following characterization: “Noseless Bicycle Saddles—What You Need to Know.” *Electro Heart Beats.*, Mar. 15, 2014 [online], [retrieved on Jul. 8, 2016]. Retrieved from the Internet <URL: <http://www.electroheartbeats.com/2014/03/noseless-bicycle-saddles-what-youneed.html>>.

Patent Cooperation Treaty, “International Search Report and Written Opinion”, issued in International Application No. PCT/US2017/048420, by European Searching Authority, document of 15 pages, Nov. 8, 2017.

U.S. Appl. No. 29/635,828, filed Aug. 8, 2019 with the following characterization: Syncros, 2017 Syncros Catalogue: Precision Bicycle Products, p. 008 (Nov. 13, 2016), [online], [site visited Jul. 29, 2019]. Available from internet, <URL: Retrieved from https://issuu.com/rideonscott/docs/2017_catalogue_syncros_en_lo>.

* cited by examiner

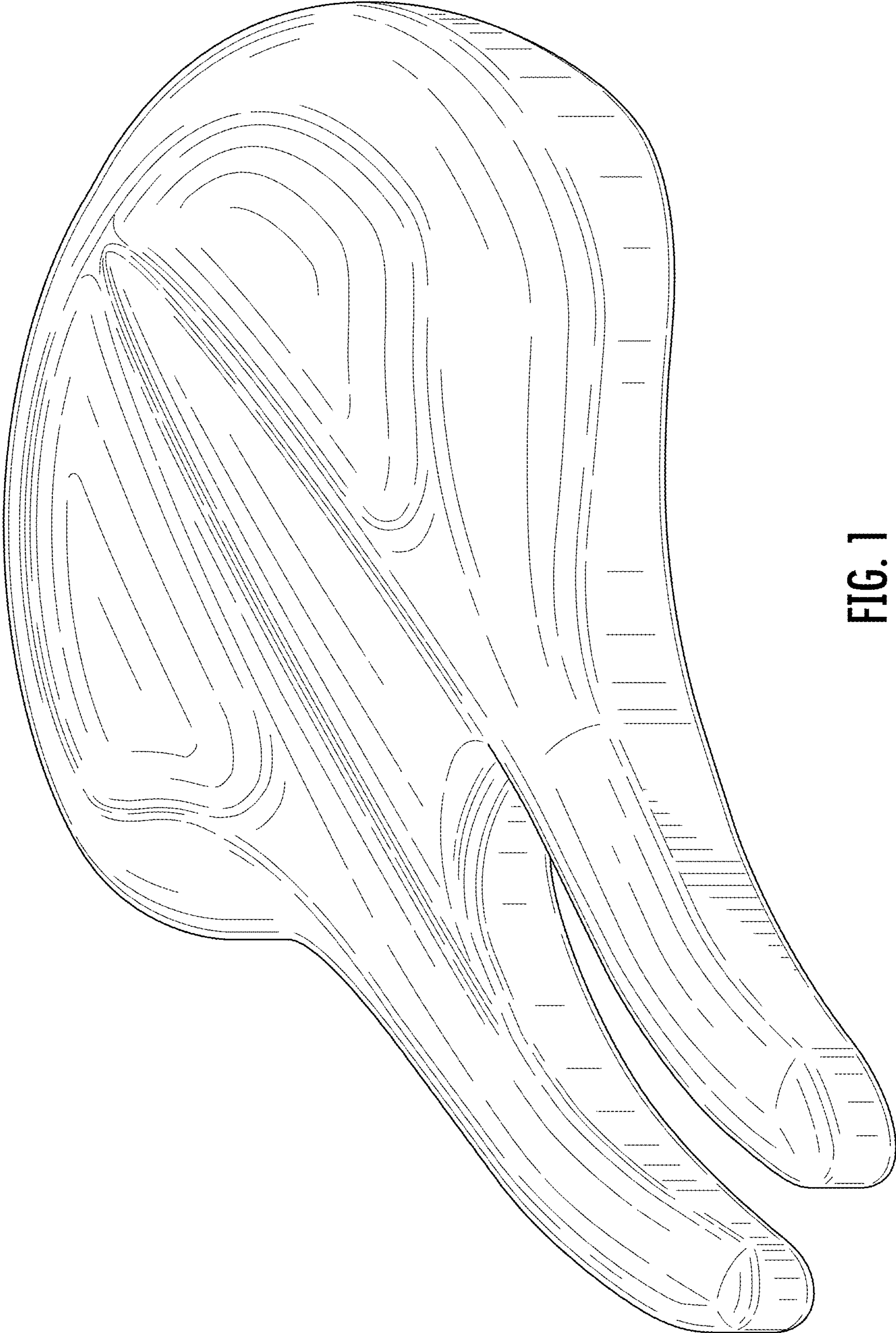

FIG. 1

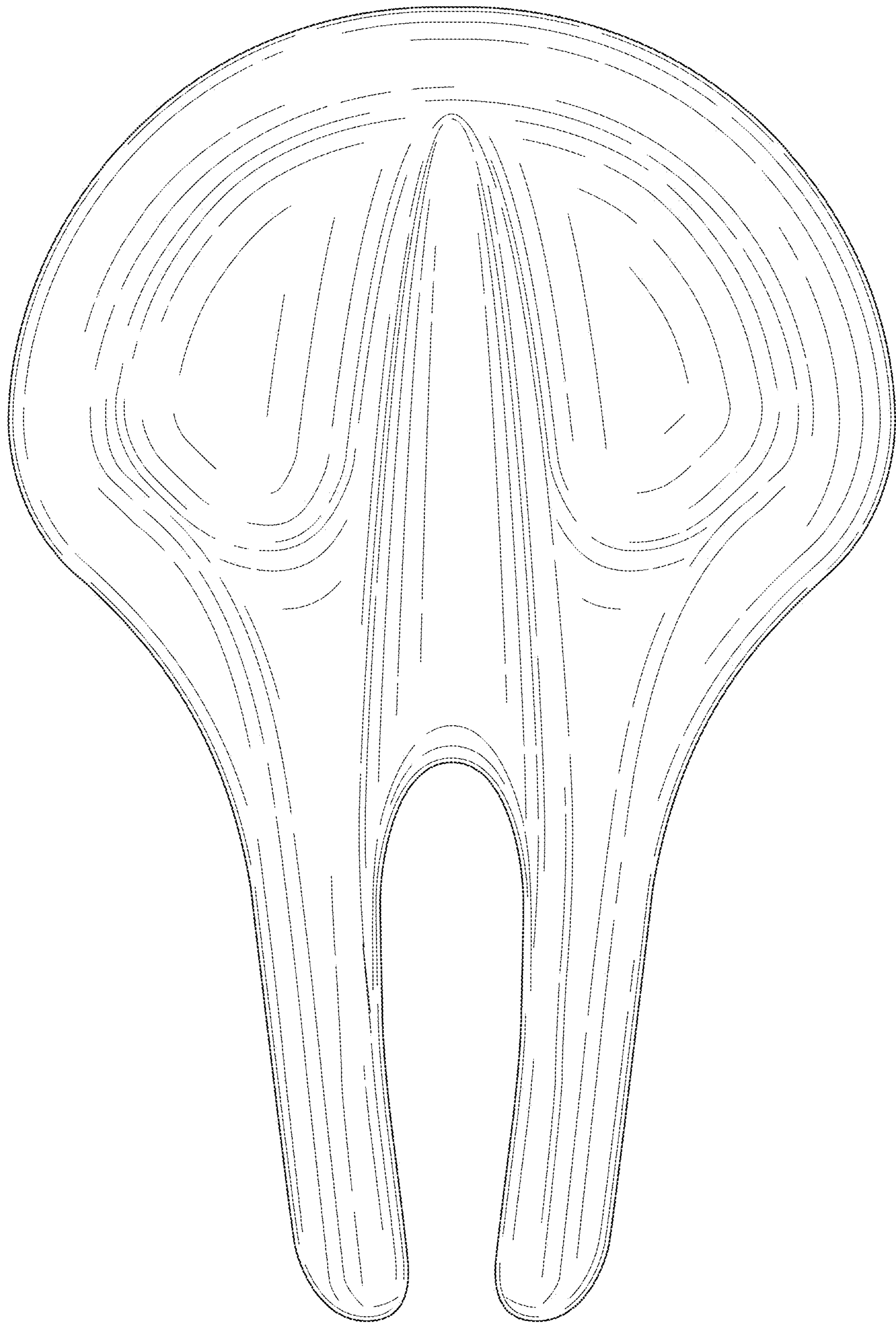

FIG. 2

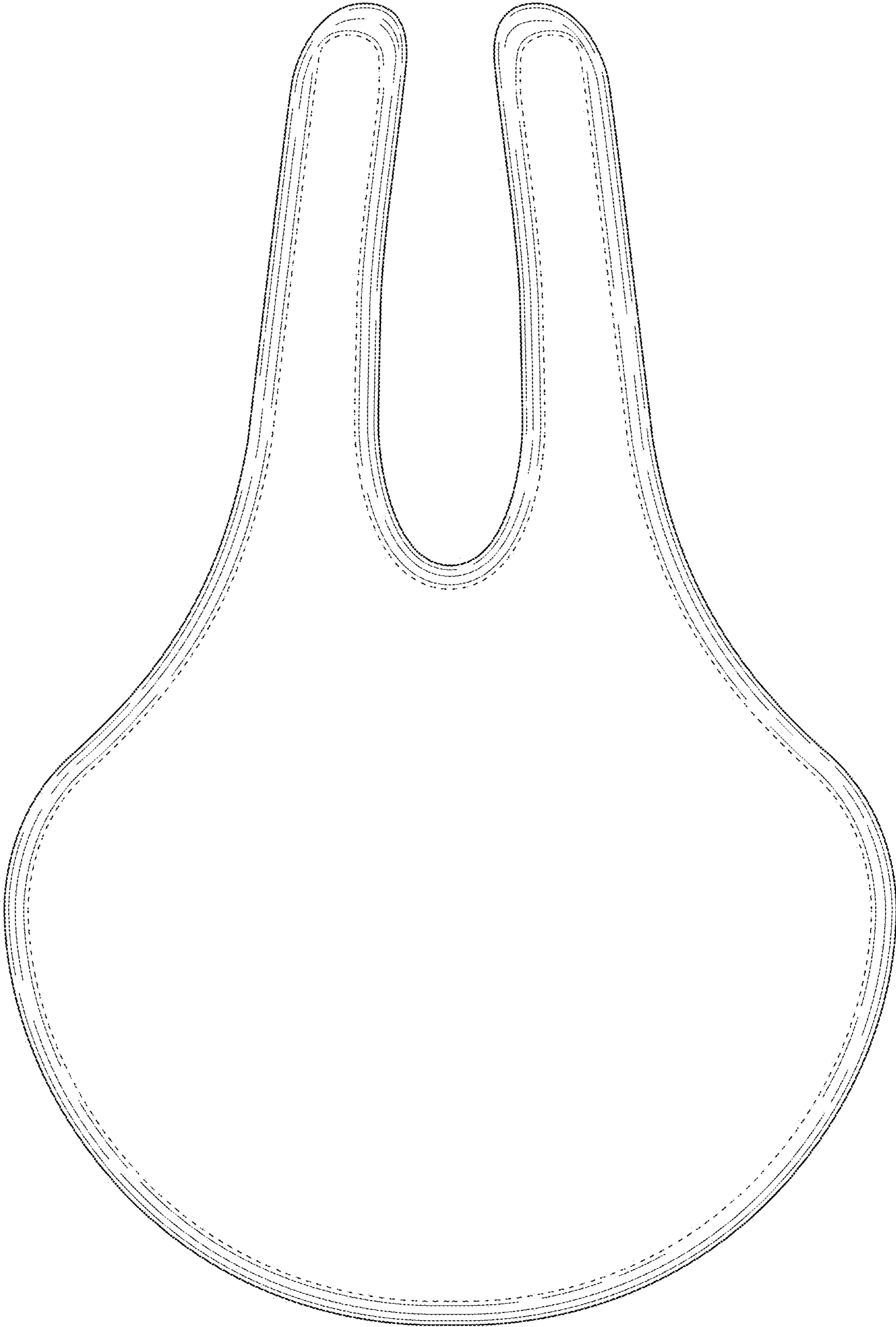

FIG. 3

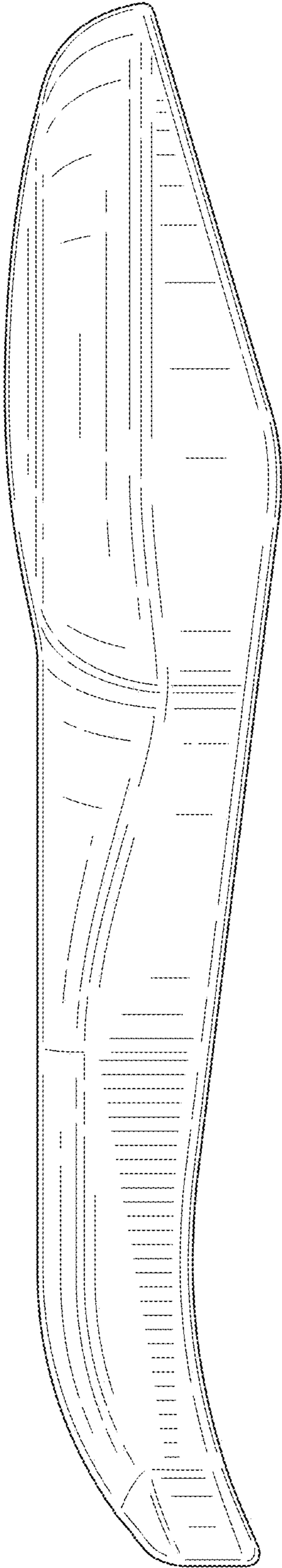

FIG. 4

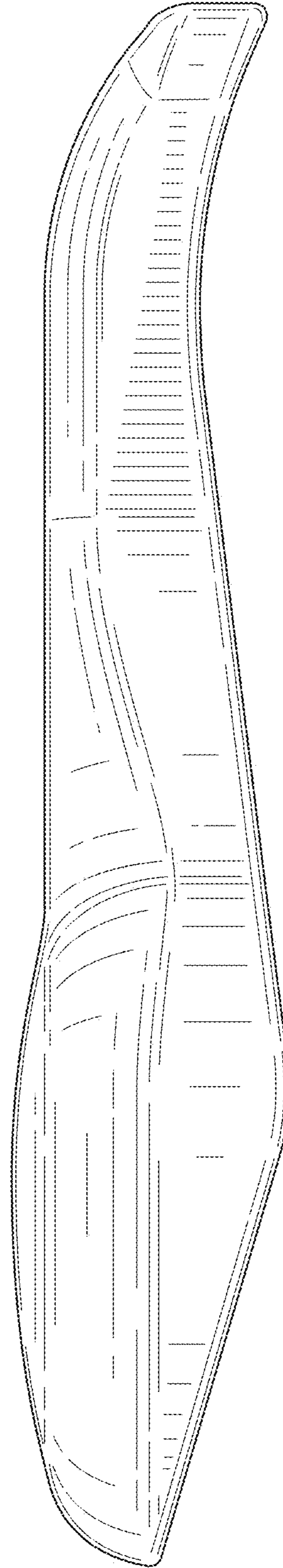

FIG. 5

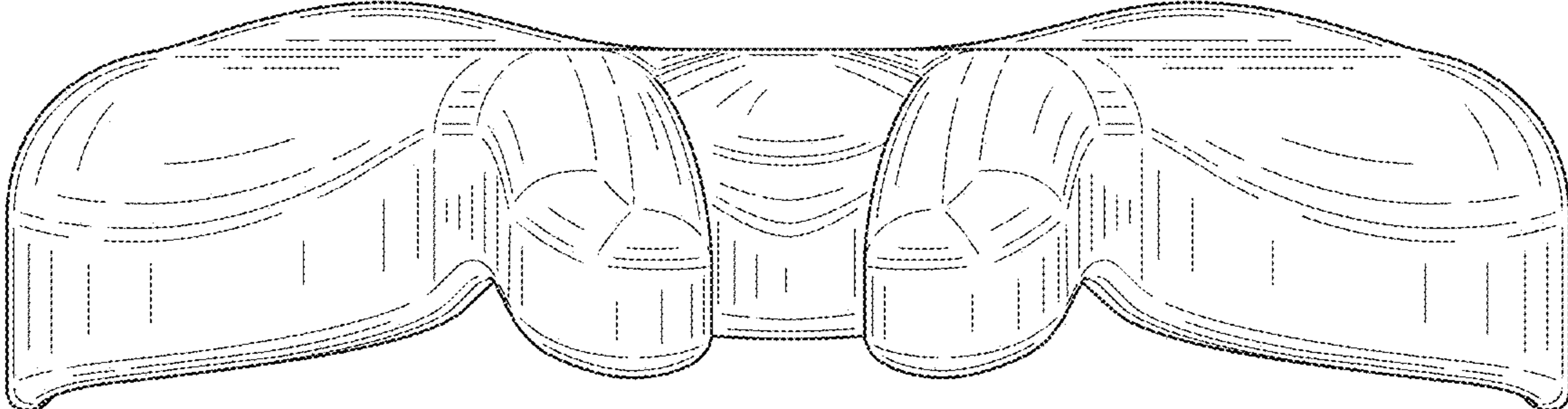

FIG. 6

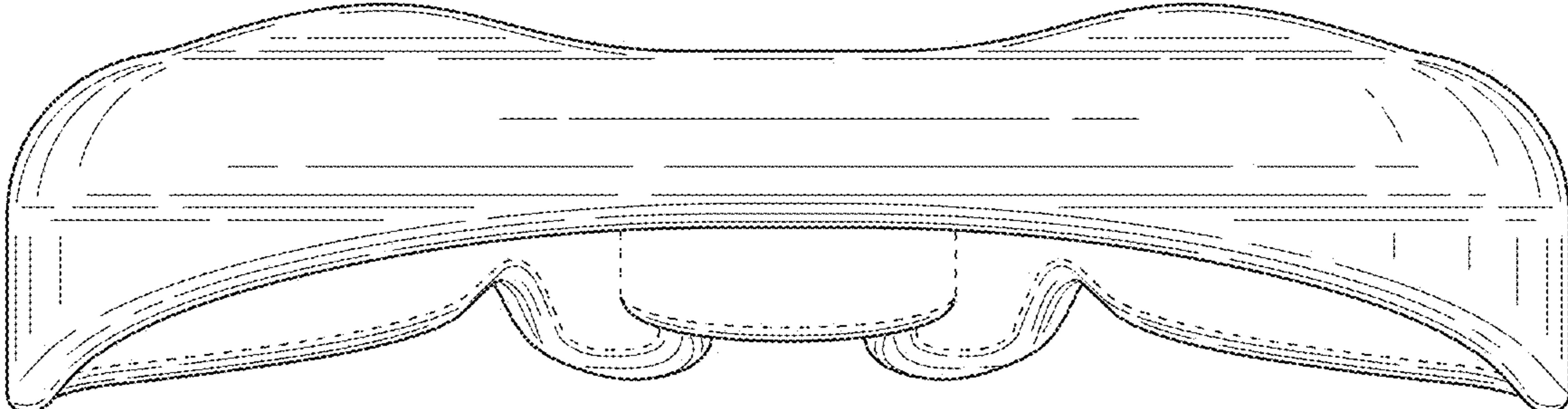

FIG. 7

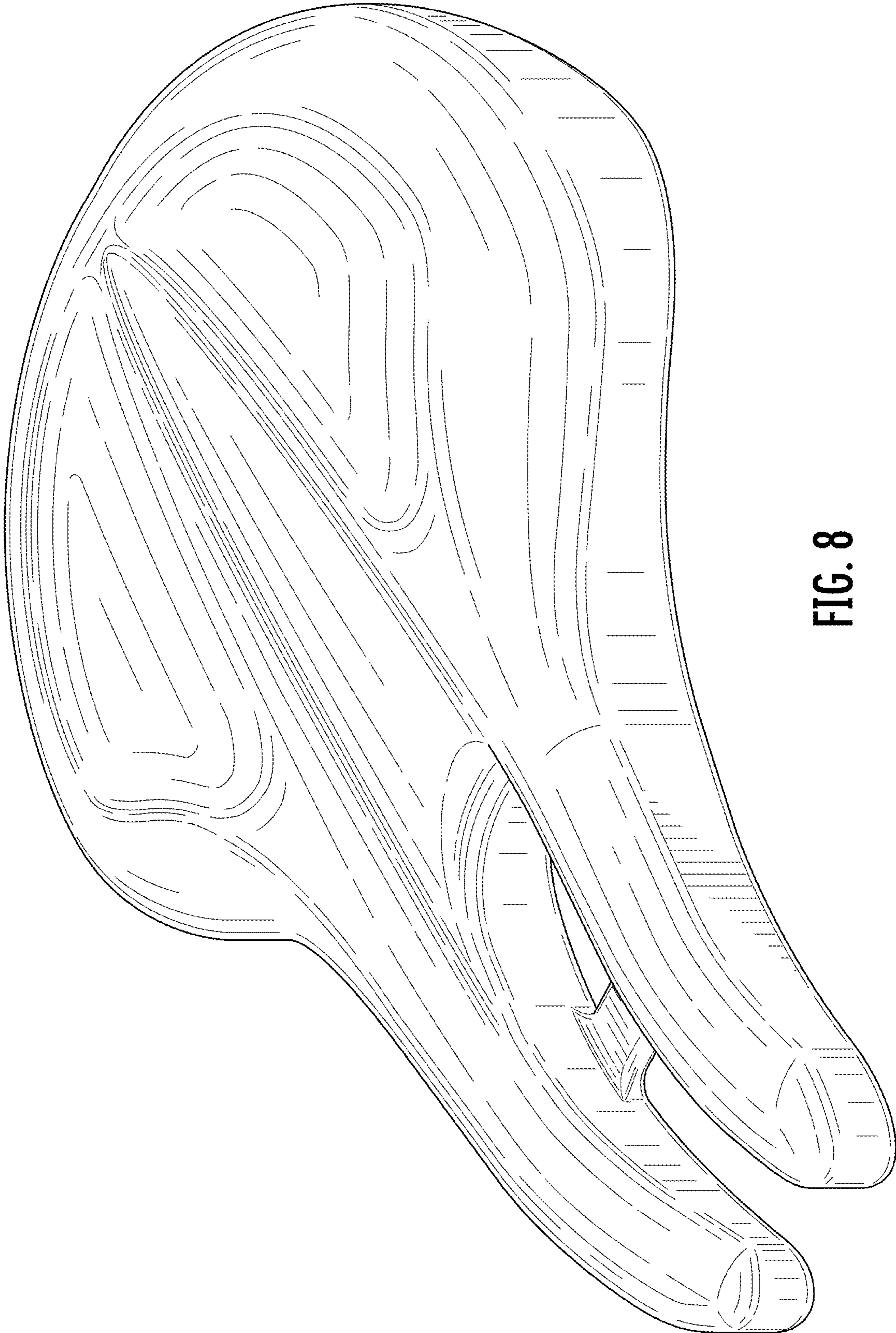

FIG. 8

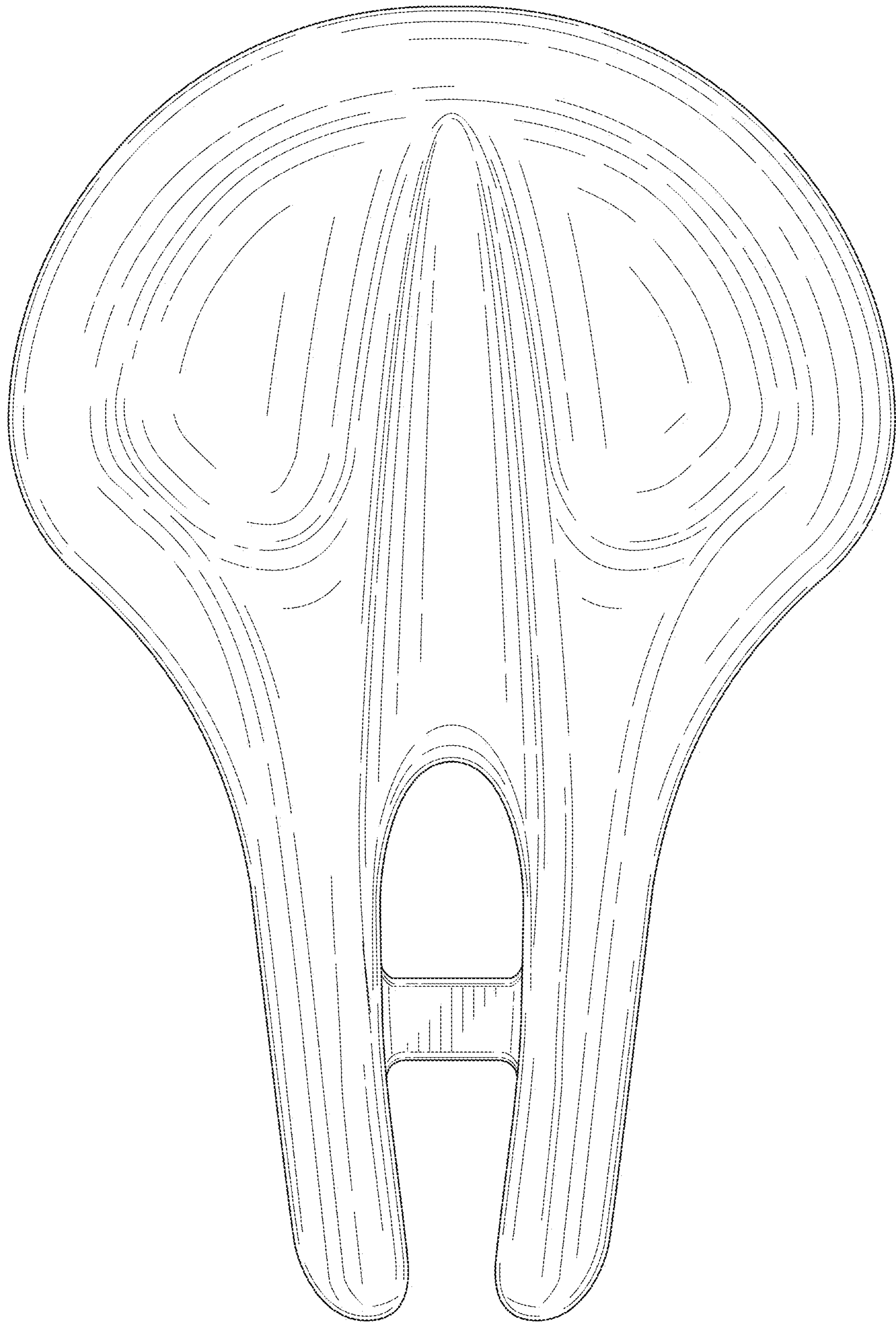

FIG. 9

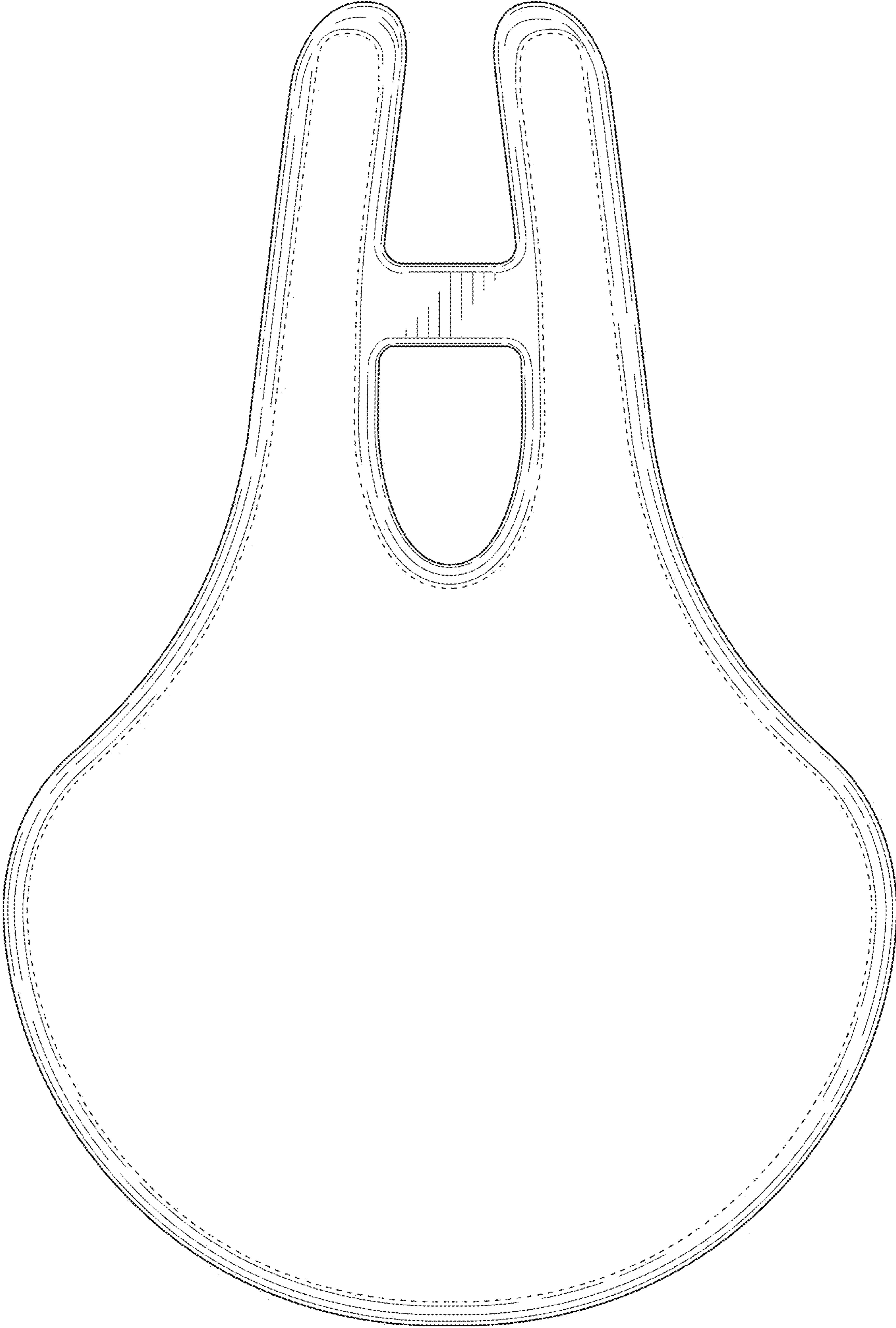

FIG. 10

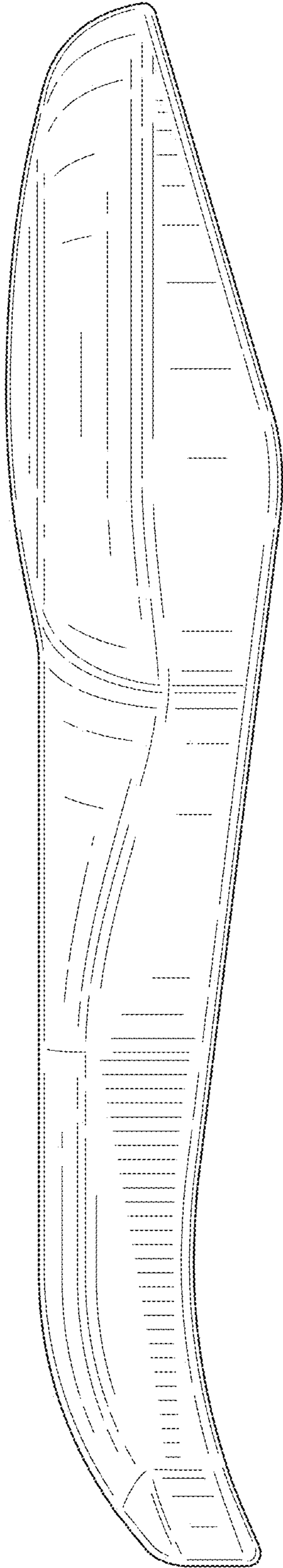

FIG. 11

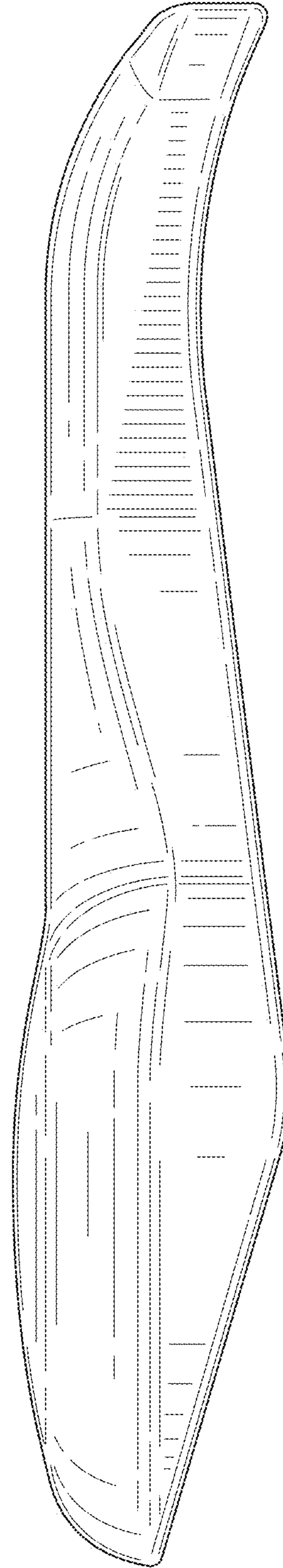

FIG. 12

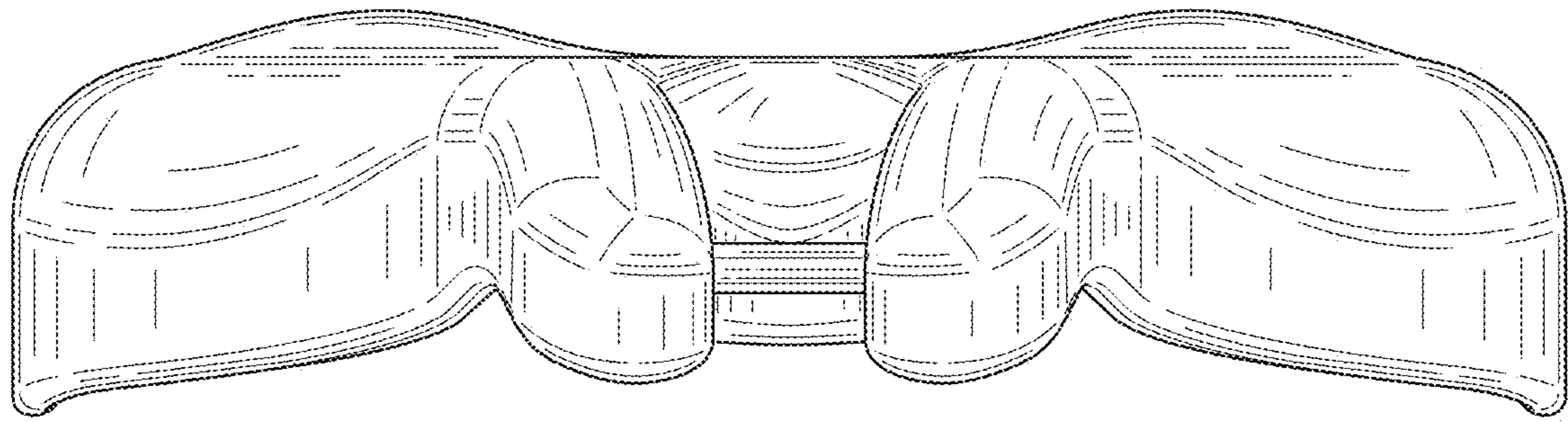

FIG. 13

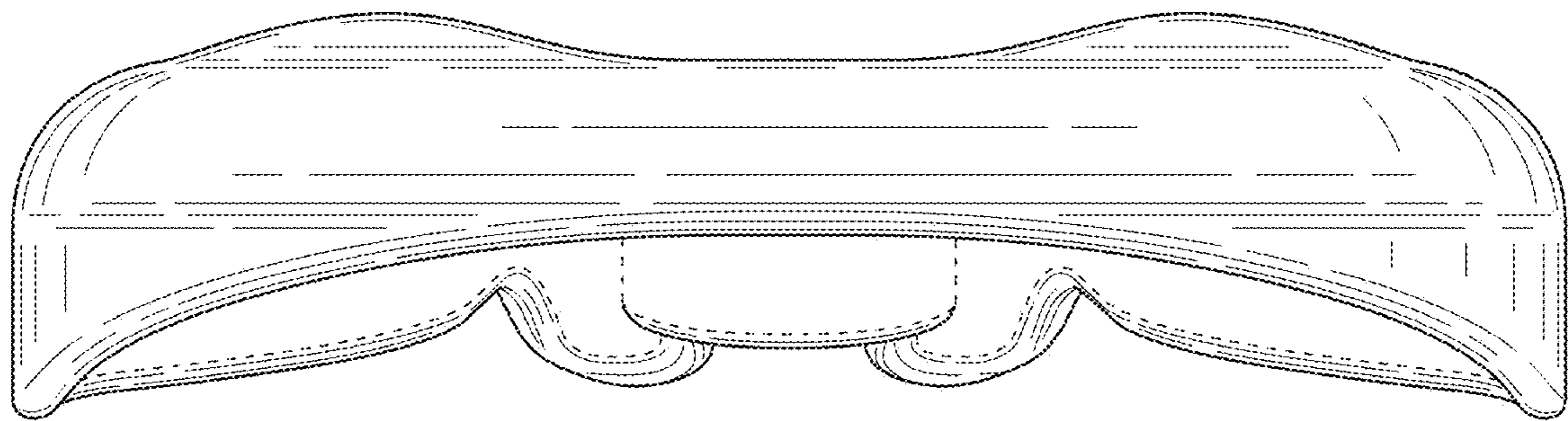

FIG. 14