



US00D903877S

(12) **United States Design Patent** (10) **Patent No.:** **US D903,877 S**
Pace et al. (45) **Date of Patent:** **** Dec. 1, 2020**

(54) **ANALYTE SENSOR DEVICE**
(71) Applicant: **ABBOTT DIABETES CARE INC.**,
Alameda, CA (US)
(72) Inventors: **Louis Pace**, San Carlos, CA (US);
Peter G. Robinson, Alamo, CA (US);
Joel Goldsmith, Oakland, CA (US)
(73) Assignee: **ABBOTT DIABETES CARE INC.**,
Alameda, CA (US)
(**) Term: **15 Years**
(21) Appl. No.: **29/678,184**
(22) Filed: **Jan. 25, 2019**

(56) **References Cited**
U.S. PATENT DOCUMENTS
3,132,123 A 5/1964 Harris, Jr. et al.
3,260,656 A 7/1966 Ross, Jr.
3,522,807 A 8/1970 Millenbach
3,581,062 A 5/1971 Aston
3,653,841 A 4/1972 Klein
3,670,727 A 6/1972 Reiterman
3,719,564 A 3/1973 Lilly, Jr. et al.
(Continued)

FOREIGN PATENT DOCUMENTS

CA 2291105 12/1998
CN 1202872 5/2005
(Continued)

Primary Examiner — Anhdao Doan
(74) *Attorney, Agent, or Firm* — McAndrews, Held & Malloy, Ltd.

Related U.S. Application Data

(63) Continuation of application No. 15/908,616, filed on Feb. 28, 2018, which is a continuation of application No. 15/610,334, filed on May 31, 2017, now Pat. No. 9,931,066, which is a continuation of application No. 15/193,499, filed on Jun. 27, 2016, now Pat. No. 9,693,713, which is a continuation of application No. 13/710,460, filed on Dec. 11, 2012, now Pat. No. 9,402,570.

(51) **LOC (12) Cl.** **24-01**

(52) **U.S. Cl.**
USPC **D24/186**; D24/169

(58) **Field of Classification Search**
USPC D24/164–169, 186, 107, 216, 111, 112,
D24/114; D10/81

CPC A61B 5/15403; A61B 5/14532; A61B
5/14865; A61B 2560/0412; A61B
2560/0443; A61B 2560/0462; A61M
25/0606; A61M 25/0631; G01N 33/66

See application file for complete search history.

(57) **CLAIM**
The ornamental design for an analyte sensor device, as shown and described.

DESCRIPTION

FIG. 1 is a front perspective view of an analyte sensor device with an environment;
FIG. 2 is a front perspective view thereof;
FIG. 3 is an enlarged front perspective view of area 3 of FIG. 2;
FIG. 4 is a top plan view thereof;
FIG. 5 is a bottom plan view thereof;
FIG. 6 is a front view thereof;
FIG. 7 is a left side view thereof;
FIG. 8 is a right side view thereof; and,
FIG. 9 is a rear view thereof.

The broken lines immediately adjacent the shaded areas represent the bounds of the claim, and the remaining broken lines are directed to environment and are for illustrative purposes only; the broken lines form no part of the claimed design.

1 Claim, 8 Drawing Sheets

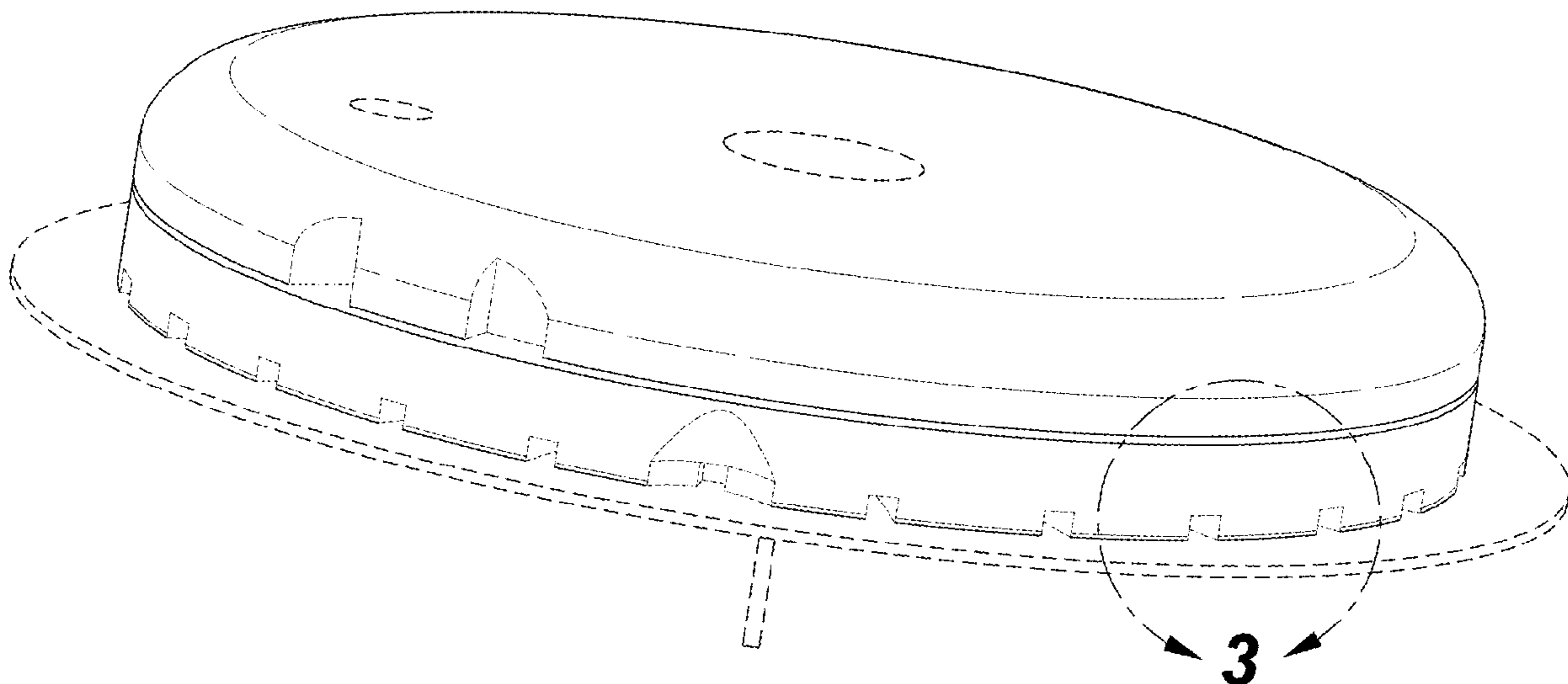

(56)

References Cited

U.S. PATENT DOCUMENTS

3,776,832 A	12/1973	Oswin et al.	4,627,908 A	12/1986	Miller
3,837,339 A	9/1974	Aisenberg et al.	4,633,878 A	1/1987	Bombardien
3,926,760 A	12/1975	Allen et al.	4,637,403 A	1/1987	Garcia et al.
3,949,388 A	4/1976	Fuller	4,650,547 A	3/1987	Gough
3,972,320 A	8/1976	Kalman	4,654,197 A	3/1987	Lilja et al.
3,979,274 A	9/1976	Newman	4,655,880 A	4/1987	Liu
4,008,717 A	2/1977	Kowarski	4,655,885 A	4/1987	Hill et al.
4,016,866 A	4/1977	Lawton	4,663,824 A	5/1987	Kenmochi
4,036,749 A	7/1977	Anderson	4,671,288 A	6/1987	Gough
4,055,175 A	10/1977	Clemens et al.	4,679,562 A	7/1987	Luksha
4,059,406 A	11/1977	Fleet	4,680,268 A	7/1987	Clark, Jr.
4,076,596 A	2/1978	Connery et al.	4,682,602 A	7/1987	Prohaska
4,098,574 A	7/1978	Dappen	4,684,537 A	8/1987	Graetzel et al.
4,100,048 A	7/1978	Pompei et al.	4,685,463 A	8/1987	Williams
4,120,292 A	10/1978	LeBlanc, Jr. et al.	4,685,466 A	8/1987	Rau
4,129,128 A	12/1978	McFarlane	4,698,057 A	10/1987	Joishy
4,151,845 A	5/1979	Clemens	4,703,756 A	11/1987	Gough et al.
4,168,205 A	9/1979	Danniger et al.	4,711,245 A	12/1987	Higgins et al.
4,172,770 A	10/1979	Semersky et al.	4,711,247 A	12/1987	Fishman
4,178,916 A	12/1979	McNamara	4,717,673 A	1/1988	Wrighton et al.
4,206,755 A	6/1980	Klein	4,721,601 A	1/1988	Wrighton et al.
4,224,125 A	9/1980	Nakamura et al.	4,721,677 A	1/1988	Clark, Jr.
4,240,438 A	12/1980	Updike et al.	4,726,378 A	2/1988	Kaplan
4,245,634 A	1/1981	Albisser et al.	4,726,716 A	2/1988	McGuire
4,247,297 A	1/1981	Berti et al.	4,729,672 A	3/1988	Takagi
4,294,258 A	10/1981	Bernard	4,731,726 A	3/1988	Allen, III
4,327,725 A	5/1982	Cortese et al.	4,749,985 A	6/1988	Corsberg
4,340,458 A	7/1982	Lerner et al.	4,755,173 A	7/1988	Konopka
4,344,438 A	8/1982	Schultz	4,757,022 A	7/1988	Shults et al.
4,349,728 A	9/1982	Phillips et al.	4,758,323 A	7/1988	Davis et al.
4,352,960 A	10/1982	Dormer et al.	4,759,371 A	7/1988	Franetzki
4,353,888 A	10/1982	Sefton	4,759,828 A	7/1988	Young et al.
4,356,074 A	10/1982	Johnson	4,764,416 A	8/1988	Ueyama et al.
4,365,637 A	12/1982	Johnson	4,776,944 A	10/1988	Janata et al.
4,366,033 A	12/1982	Richter et al.	4,777,953 A	10/1988	Ash et al.
4,373,527 A	2/1983	Fischell	4,779,618 A	10/1988	Gough
4,375,399 A	3/1983	Havas et al.	4,781,683 A	11/1988	Wozniak et al.
4,384,586 A	5/1983	Christiansen	4,781,798 A	11/1988	Gough
4,390,621 A	6/1983	Bauer	4,784,736 A	11/1988	Lonsdale et al.
4,401,122 A	8/1983	Clark, Jr.	4,795,707 A	1/1989	Niiyama et al.
4,404,066 A	9/1983	Johnson	4,796,634 A	1/1989	Huntsman et al.
4,418,148 A	11/1983	Oberhardt	4,805,624 A	2/1989	Yao et al.
4,425,920 A	1/1984	Bourland et al.	4,813,424 A	3/1989	Wilkins
4,427,004 A	1/1984	Miller et al.	4,815,469 A	3/1989	Cohen et al.
4,427,770 A	1/1984	Chen et al.	4,820,399 A	4/1989	Senda et al.
4,431,004 A	2/1984	Bessman et al.	4,822,337 A	4/1989	Newhouse et al.
4,436,094 A	3/1984	Cerami	4,830,959 A	5/1989	McNeil et al.
4,440,175 A	4/1984	Wilkins	4,832,797 A	5/1989	Vadgama et al.
4,450,842 A	5/1984	Zick et al.	4,840,893 A	6/1989	Dormer et al.
4,458,686 A	7/1984	Clark, Jr.	4,848,351 A	6/1989	Hill et al.
4,461,691 A	7/1984	Frank	4,854,322 A	7/1989	Finch
4,469,110 A	9/1984	Slama	4,871,351 A	8/1989	Ash et al.
4,477,314 A	10/1984	Richter et al.	4,871,440 A	10/1989	Feingold
4,478,976 A	10/1984	Goertz et al.	4,874,500 A	10/1989	Nagata et al.
4,484,987 A	11/1984	Gough	4,874,500 A	10/1989	Madou et al.
4,494,950 A	1/1985	Fischell	4,890,622 A	1/1990	Gough
4,509,531 A	4/1985	Ward	4,894,137 A	1/1990	Takizawa et al.
4,522,690 A	6/1985	Venkatsetty	4,895,147 A	1/1990	Bodicky et al.
4,524,114 A	6/1985	Samuels et al.	4,897,162 A	1/1990	Lewandowski et al.
4,526,661 A	7/1985	Steckhan et al.	4,897,173 A	1/1990	Nankai et al.
4,527,240 A	7/1985	Kvitash	4,909,908 A	3/1990	Ross et al.
4,534,356 A	8/1985	Papadakis	4,911,794 A	3/1990	Parce et al.
4,538,616 A	9/1985	Rogoff	4,917,800 A	4/1990	Lonsdale et al.
4,543,955 A	10/1985	Schroepfel	4,919,141 A	4/1990	Zier et al.
4,545,382 A	10/1985	Higgins et al.	4,919,767 A	4/1990	Vadgama et al.
4,552,840 A	11/1985	Riffer	4,921,199 A	5/1990	Villavecs
4,560,534 A	12/1985	Kung et al.	4,923,586 A	5/1990	Katayama et al.
4,571,292 A	2/1986	Liu et al.	4,925,268 A	5/1990	Iyer et al.
4,573,994 A	3/1986	Fischell et al.	4,927,516 A	5/1990	Yamaguchi et al.
4,581,336 A	4/1986	Malloy et al.	4,934,369 A	6/1990	Maxwell
4,595,011 A	6/1986	Phillips	4,935,105 A	6/1990	Churhouse
4,619,754 A	10/1986	Niki et al.	4,935,345 A	6/1990	Guibeau et al.
4,619,793 A	10/1986	Lee	4,938,860 A	7/1990	Wogoman
4,627,445 A	12/1986	Garcia et al.	4,944,299 A	7/1990	Silvian
4,627,842 A	12/1986	Katz	4,950,378 A	8/1990	Nagara
			4,953,552 A	9/1990	DeMarzo
			4,954,129 A	9/1990	Giuliani et al.
			4,969,468 A	11/1990	Byers et al.
			4,970,145 A	11/1990	Bennetto et al.

(56)

References Cited

U.S. PATENT DOCUMENTS

4,974,929 A	12/1990	Curry	5,372,427 A	12/1994	Padovani et al.
4,986,271 A	1/1991	Wilkins	5,376,251 A	12/1994	Kaneko et al.
4,988,341 A	1/1991	Columbus et al.	5,378,628 A	1/1995	Gratzel et al.
4,994,167 A	2/1991	Shults et al.	5,379,238 A	1/1995	Stark
4,995,402 A	2/1991	Smith et al.	5,387,327 A	2/1995	Khan
5,000,180 A	3/1991	Kuypers et al.	5,390,671 A	2/1995	Lord et al.
5,001,054 A	3/1991	Wagner	5,391,250 A	2/1995	Cheney, II et al.
5,013,161 A	5/1991	Zaragoza et al.	5,395,504 A	3/1995	Saurer et al.
5,019,974 A	5/1991	Beckers	5,400,782 A	3/1995	Beaubiah
5,035,860 A	7/1991	Kleingeld et al.	5,408,999 A	4/1995	Singh et al.
5,036,860 A	8/1991	Leigh et al.	5,411,647 A	5/1995	Johnson et al.
5,047,044 A	9/1991	Smith et al.	5,425,361 A	6/1995	Fenzlein et al.
5,050,612 A	9/1991	Matsumura	5,431,160 A	7/1995	Wilkins
5,055,171 A	10/1991	Peck	5,431,921 A	7/1995	Thombre
5,058,592 A	10/1991	Whisler	5,437,999 A	8/1995	Dieboid et al.
5,070,535 A	12/1991	Hochmair et al.	5,462,645 A	10/1995	Albery et al.
5,082,550 A	1/1992	Rishpon et al.	5,469,846 A	11/1995	Khan
5,082,786 A	1/1992	Nakamoto	5,472,317 A	12/1995	Field et al.
5,089,112 A	2/1992	Skotheim et al.	5,489,414 A	2/1996	Schreiber et al.
5,095,904 A	3/1992	Seligman et al.	5,491,474 A	2/1996	Suni et al.
5,101,814 A	4/1992	Palti	5,494,562 A	2/1996	Maley et al.
5,106,365 A	4/1992	Hernandez	5,496,453 A	3/1996	Uenoyama et al.
5,108,564 A	4/1992	Szuminsky et al.	5,497,772 A	3/1996	Schulman et al.
5,108,889 A	4/1992	Smith et al.	5,507,288 A	4/1996	Bocker et al.
5,109,850 A	5/1992	Blanco et al.	5,509,410 A	4/1996	Hill et al.
5,120,420 A	6/1992	Nankai et al.	5,514,718 A	5/1996	Lewis et al.
5,122,925 A	6/1992	Inpyn	5,531,878 A	7/1996	Vadgama et al.
5,126,034 A	6/1992	Carter et al.	5,545,191 A	8/1996	Mann et al.
5,133,856 A	7/1992	Yamaguchi et al.	5,549,368 A	8/1996	Shields
5,135,003 A	8/1992	Souma	5,551,427 A	9/1996	Altman
5,140,985 A	8/1992	Schroeder et al.	5,560,357 A	10/1996	Faupei et al.
5,141,868 A	8/1992	Shanks et al.	5,562,713 A	10/1996	Silvian
5,161,532 A	11/1992	Joseph	5,565,085 A	10/1996	Ikeda et al.
5,165,407 A	11/1992	Wilson et al.	5,567,302 A	10/1996	Song et al.
5,174,291 A	12/1992	Schoonen et al.	5,568,806 A	10/1996	Cheney, II et al.
5,190,041 A	3/1993	Palti	5,569,186 A	10/1996	Lord et al.
5,192,416 A	3/1993	Wang et al.	5,575,563 A	11/1996	Chiu et al.
5,198,367 A	3/1993	Aizawa et al.	5,582,184 A	12/1996	Erickson et al.
5,202,261 A	4/1993	Musho et al.	5,582,697 A	12/1996	Ikeda et al.
5,205,920 A	4/1993	Oyama et al.	5,582,698 A	12/1996	Flaherty et al.
5,208,154 A	5/1993	Weaver et al.	5,584,813 A	12/1996	Livingston et al.
5,209,229 A	5/1993	Gilli	5,586,553 A	12/1996	Halli et al.
5,217,595 A	6/1993	Smith et al.	5,589,326 A	12/1996	Deng et al.
5,229,282 A	7/1993	Yoshioka et al.	5,593,852 A	1/1997	Heller et al.
5,234,835 A	8/1993	Nestor et al.	5,596,150 A	1/1997	Arndt et al.
5,238,729 A	8/1993	Debe	5,601,435 A	2/1997	Quy
5,246,867 A	9/1993	Lakowicz et al.	5,609,575 A	3/1997	Larson et al.
5,250,439 A	10/1993	Musho et al.	5,613,978 A	3/1997	Harding
5,262,035 A	11/1993	Gregg et al.	5,617,851 A	4/1997	Lipkovker
5,262,305 A	11/1993	Heller et al.	5,628,310 A	5/1997	Rao et al.
5,264,103 A	11/1993	Yoshioka et al.	5,628,890 A	5/1997	Carter et al.
5,264,104 A	11/1993	Gregg et al.	5,632,557 A	5/1997	Simons
5,264,105 A	11/1993	Gregg et al.	5,640,954 A	6/1997	Pfeiffer et al.
5,264,106 A	11/1993	McAleer et al.	5,651,869 A	7/1997	Yoshioka et al.
5,271,815 A	12/1993	Wong	5,653,239 A	8/1997	Pompei et al.
5,279,294 A	1/1994	Anderson	5,660,163 A	8/1997	Schulman et al.
5,284,156 A	2/1994	Schramm et al.	5,665,071 A	9/1997	Wyrick
5,285,792 A	2/1994	Sjoquist et al.	5,665,222 A	9/1997	Heller et al.
5,286,362 A	2/1994	Hoenes et al.	5,670,031 A	9/1997	Hintsche et al.
5,286,364 A	2/1994	Yacynych et al.	5,680,858 A	10/1997	Hansen et al.
5,288,636 A	2/1994	Pollmann et al.	5,682,233 A	10/1997	Brinda
5,293,546 A	3/1994	Tadros et al.	5,695,623 A	12/1997	Michel et al.
5,293,877 A	3/1994	O'Hara et al.	5,708,247 A	1/1998	McAleer et al.
5,299,571 A	4/1994	Mastrototaro	5,711,001 A	1/1998	Bussan et al.
5,320,098 A	6/1994	Davidson	5,711,297 A	1/1998	Iliff et al.
5,320,725 A	6/1994	Gregg et al.	5,711,861 A	1/1998	Ward et al.
5,322,063 A	6/1994	Allen et al.	5,711,862 A	1/1998	Sakoda et al.
5,337,747 A	8/1994	Neftei	5,733,044 A	3/1998	Rose et al.
5,340,722 A	8/1994	Wolfbeis et al.	5,735,285 A	4/1998	Albert et al.
5,342,789 A	8/1994	Chick et al.	5,741,211 A	4/1998	Renirie et al.
5,352,348 A	10/1994	Young et al.	5,749,656 A	5/1998	Boehm et al.
5,356,786 A	10/1994	Heller et al.	5,766,131 A	6/1998	Kondo et al.
5,360,404 A	11/1994	Novacek et al.	5,771,001 A	6/1998	Cobb
5,368,028 A	11/1994	Palti	5,772,586 A	6/1998	Heinonen et al.
5,372,133 A	12/1994	Hogen Esch	5,779,665 A	7/1998	Mastrototaro et al.
			5,791,344 A	8/1998	Schulman et al.
			5,800,420 A	9/1998	Gross et al.
			5,807,375 A	9/1998	Gross et al.
			5,814,020 A	9/1998	Gross

(56)

References Cited

U.S. PATENT DOCUMENTS

5,820,551 A	10/1998	Hill et al.	6,360,888 B1	3/2002	McIvor et al.
5,820,622 A	10/1998	Gross et al.	6,368,141 B1	4/2002	Van Antwerp et al.
5,822,715 A	10/1998	Worthington et al.	6,368,274 B1	4/2002	Van Antwerp et al.
5,827,184 A	10/1998	Netherly et al.	6,377,828 B1	4/2002	Chaiken et al.
5,840,020 A	11/1998	Heinonen et al.	6,379,301 B1	4/2002	Worthington et al.
5,842,983 A	12/1998	Abel et al.	6,409,740 B1	6/2002	Kuhr et al.
5,851,197 A	12/1998	Marano et al.	6,413,393 B1	7/2002	Van Antwerp et al.
5,858,001 A	1/1999	Tsals et al.	6,418,332 B1	7/2002	Mastrototaro et al.
5,865,804 A	2/1999	Bachynsky	6,424,847 B1	7/2002	Mastrototaro et al.
5,885,211 A	3/1999	Eppstein et al.	6,427,088 B1	7/2002	Bowman, IV et al.
5,899,855 A	5/1999	Brown	6,437,679 B1	8/2002	Rogues
5,924,979 A	7/1999	Sedlow et al.	6,440,068 B1	8/2002	Brown et al.
5,925,021 A	7/1999	Castellano et al.	6,445,374 B2	9/2002	Albert et al.
5,931,814 A	8/1999	Alex et al.	6,478,736 B1	11/2002	Mault
5,948,006 A	9/1999	Mann	6,482,176 B1	11/2002	Wich
5,951,521 A	9/1999	Mastrototaro et al.	6,484,045 B1	11/2002	Holker et al.
5,954,643 A	9/1999	Van Antwerp	6,484,046 B1	11/2002	Say et al.
5,954,685 A	9/1999	Tierny	6,514,718 B2	2/2003	Heller et al.
5,957,854 A	9/1999	Besson et al.	6,520,326 B2	2/2003	McIvor et al.
5,961,451 A	10/1999	Reber et al.	6,522,927 B1	2/2003	Bishay et al.
5,964,993 A	10/1999	Blubaugh, Jr. et al.	6,551,494 B1	4/2003	Heller et al.
5,965,380 A	10/1999	Heller et al.	6,554,798 B1	4/2003	Mann et al.
5,971,922 A	10/1999	Arita et al.	6,558,320 B1	5/2003	Causey, III et al.
5,972,199 A	10/1999	Heller et al.	6,558,321 B1	5/2003	Burd et al.
5,987,353 A	11/1999	Khatchatrian et al.	6,560,471 B1	5/2003	Heller et al.
5,993,411 A	11/1999	Choi	6,561,978 B1	5/2003	Conn et al.
5,995,860 A	11/1999	Sun et al.	6,562,001 B2	5/2003	Lebel et al.
5,997,501 A	12/1999	Gross et al.	6,564,105 B2	5/2003	Starkweather et al.
6,001,067 A	12/1999	Shults et al.	6,565,509 B1	5/2003	Say et al.
6,004,278 A	12/1999	Botich et al.	6,571,128 B2	5/2003	Lebel et al.
6,017,335 A	1/2000	Burnham	6,572,566 B2	6/2003	Effenhauser
6,022,368 A	2/2000	Gavronsky et al.	6,576,101 B1	6/2003	Heller et al.
6,024,699 A	2/2000	Surwit et al.	6,577,899 B2	6/2003	Lebel et al.
6,026,321 A	2/2000	Miyata et al.	6,579,690 B1	6/2003	Bonnecaze et al.
6,027,459 A	2/2000	Shain et al.	6,585,644 B2	7/2003	Lebel et al.
6,049,727 A	4/2000	Crothall	6,589,229 B1	7/2003	Connelly et al.
6,056,718 A	5/2000	Funderburk et al.	6,591,125 B1	7/2003	Buse et al.
6,068,399 A	5/2000	Tseng	6,595,919 B2	7/2003	Berner et al.
6,083,710 A	7/2000	Heller et al.	6,605,200 B1	8/2003	Mao et al.
6,088,608 A	7/2000	Schulman et al.	6,605,201 B1	8/2003	Mao et al.
6,091,975 A	7/2000	Daddona et al.	6,607,509 B2	8/2003	Bobroff et al.
6,091,976 A	7/2000	Pfeiffer et al.	6,610,012 B2	8/2003	Mault
6,093,172 A	7/2000	Funderburk et al.	6,633,772 B2	10/2003	Ford et al.
6,103,033 A	8/2000	Say et al.	6,635,014 B2	10/2003	Starkweather et al.
6,117,290 A	9/2000	Say et al.	6,648,821 B2	11/2003	Lebel et al.
6,119,028 A	9/2000	Schulman et al.	6,654,625 B1	11/2003	Say et al.
6,120,676 A	9/2000	Heller et al.	6,659,948 B2	12/2003	Lebel et al.
6,121,009 A	9/2000	Heller et al.	6,666,849 B1	12/2003	Marshall et al.
6,121,611 A	9/2000	Lindsay et al.	6,668,196 B1	12/2003	Villegas et al.
6,122,351 A	9/2000	Schlueter, Jr. et al.	6,676,290 B1	1/2004	Lu
6,134,461 A	10/2000	Say et al.	6,687,546 B2	2/2004	Lebel et al.
6,143,164 A	11/2000	Heller et al.	6,689,056 B1	2/2004	Kilcoyne et al.
6,159,147 A	12/2000	Lichter et al.	6,694,191 B2	2/2004	Starkweather et al.
6,162,611 A	12/2000	Heller et al.	6,695,860 B1	2/2004	Ward et al.
6,175,752 B1	1/2001	Say et al.	6,702,857 B2	3/2004	Brauker et al.
6,186,982 B1	2/2001	Gross et al.	6,733,446 B2	5/2004	Lebel et al.
6,200,265 B1	3/2001	Walsh et al.	6,740,075 B2	5/2004	Lebel et al.
6,212,416 B1	4/2001	Ward et al.	6,741,877 B1	5/2004	Shults et al.
6,219,574 B1	4/2001	Cormier et al.	6,746,582 B2	6/2004	Heller et al.
6,248,067 B1	6/2001	Causey, III et al.	6,758,810 B2	7/2004	Lebel et al.
6,254,536 B1	7/2001	DeVito	6,770,030 B1	8/2004	Schaupp et al.
6,254,586 B1	7/2001	Mann et al.	6,790,178 B1	9/2004	Mault et al.
6,275,717 B1	8/2001	Gross et al.	6,809,653 B1	10/2004	Mann et al.
6,283,761 B1	9/2001	Joao	6,810,290 B2	10/2004	Lebel et al.
6,283,982 B1	9/2001	Levaughn et al.	6,811,533 B2	11/2004	Lebel et al.
6,284,478 B1	9/2001	Heller et al.	6,811,534 B2	11/2004	Bowman, IV et al.
6,293,925 B1	9/2001	Safabash et al.	6,813,519 B2	11/2004	Lebel et al.
6,295,506 B1	9/2001	Heinonen et al.	6,830,551 B1	12/2004	Uchigaki et al.
6,306,104 B1	10/2001	Cunningham et al.	6,837,858 B2	1/2005	Cunningham et al.
6,309,884 B1	10/2001	Cooper et al.	6,837,885 B2	1/2005	Koblish et al.
6,329,161 B1	12/2001	Heller et al.	6,837,988 B2	1/2005	Leong et al.
6,331,244 B1	12/2001	Lewis et al.	6,849,052 B2	2/2005	Uchigaki et al.
6,338,790 B1	1/2002	Feldman et al.	6,854,882 B2	2/2005	Chen
6,348,640 B1	2/2002	Navot et al.	6,862,465 B2	3/2005	Shults et al.
6,359,444 B1	3/2002	Grimes	6,873,268 B2	3/2005	Lebel et al.
			6,881,551 B2	4/2005	Heller et al.
			6,892,085 B2	5/2005	McIvor et al.
			6,895,265 B2	5/2005	Silver
			6,931,327 B2	8/2005	Goode, Jr. et al.

(56)

References Cited

U.S. PATENT DOCUMENTS

6,932,894 B2	8/2005	Mao et al.	7,666,149 B2	2/2010	Simons et al.
6,936,006 B2	8/2005	Sabra	7,682,338 B2	3/2010	Griffin
6,942,518 B2	9/2005	Liamos et al.	7,697,967 B2	4/2010	Stafford
6,950,708 B2	9/2005	Bowman, IV et al.	7,711,402 B2	5/2010	Shults et al.
6,958,705 B2	10/2005	Lebel et al.	7,713,574 B2	5/2010	Brister et al.
6,959,211 B2	10/2005	Rule et al.	7,715,893 B2	5/2010	Kamath et al.
6,968,294 B2	11/2005	Gutta et al.	7,727,147 B1	6/2010	Osorio et al.
6,971,274 B2	12/2005	Olin	7,731,657 B2	6/2010	Stafford
6,971,999 B2	12/2005	Py et al.	7,736,344 B2	6/2010	Moberg et al.
6,974,437 B2	12/2005	Lebel et al.	7,763,042 B2	7/2010	Iio et al.
6,990,366 B2	1/2006	Say et al.	7,822,454 B1	10/2010	Alden et al.
6,997,907 B2	2/2006	Safabash et al.	D683,636 S *	6/2013	Levanen D10/70
6,998,247 B2	2/2006	Monfre et al.	9,007,781 B2	4/2015	Moein et al.
7,003,336 B2	2/2006	Holker et al.	9,215,992 B2 *	12/2015	Donnay A61B 5/15194
7,003,340 B2	2/2006	Say et al.	9,402,544 B2 *	8/2016	Yee A61B 5/14532
7,003,341 B2	2/2006	Say et al.	9,723,082 B2 *	8/2017	Sloan A61B 5/0004
7,024,245 B2	4/2006	Lebel et al.	D815,289 S *	4/2018	Evers D24/169
7,025,743 B2	4/2006	Mann et al.	D831,831 S *	10/2018	Newhouse D24/169
7,041,068 B2	5/2006	Freeman et al.	D842,996 S *	3/2019	Frick D24/169
7,041,468 B2	5/2006	Drucker et al.	2001/0056262 A1	12/2001	Cabin et al.
7,052,483 B2	5/2006	Wojcik	2002/0013538 A1	1/2002	Teller
7,056,302 B2	6/2006	Douglas	2002/0019022 A1	2/2002	Dunn et al.
7,074,307 B2	7/2006	Simpson et al.	2002/0019606 A1	2/2002	Lebel et al.
7,081,195 B2	7/2006	Simpson et al.	2002/0022855 A1	2/2002	Bobroff et al.
7,097,637 B2	8/2006	Triplett et al.	2002/0023852 A1	2/2002	McIvor et al.
7,098,803 B2	8/2006	Mann et al.	2002/0042090 A1	4/2002	Heller et al.
7,108,778 B2	9/2006	Simpson et al.	2002/0055711 A1	5/2002	Lavi et al.
7,110,803 B2	9/2006	Shults et al.	2002/0057993 A1	5/2002	Maisey et al.
7,113,821 B1	9/2006	Sun et al.	2002/0066764 A1	6/2002	Perry et al.
7,134,999 B2	11/2006	Brauker et al.	2002/0076966 A1	6/2002	Carron et al.
7,136,689 B2	11/2006	Shults et al.	2002/0082487 A1	6/2002	Kollias et al.
7,171,274 B2	1/2007	Starkweather et al.	2002/0103499 A1	8/2002	Perez et al.
7,190,988 B2	3/2007	Say et al.	2002/0106709 A1	8/2002	Potts et al.
7,192,450 B2	3/2007	Brauker et al.	2002/0119711 A1	8/2002	Van Antwerp et al.
7,198,606 B2	4/2007	Boecker et al.	2002/0124017 A1	9/2002	Mault
7,207,974 B2	4/2007	Safabash et al.	2002/0128594 A1	9/2002	Das et al.
7,226,978 B2	6/2007	Tapsak et al.	2002/0130042 A1	9/2002	Moerman et al.
7,276,029 B2	10/2007	Goode, Jr. et al.	2002/0151796 A1	10/2002	Koulik
7,278,983 B2	10/2007	Ireland et al.	2002/0151816 A1	10/2002	Rich et al.
7,297,151 B2	11/2007	Boecker et al.	2002/0154050 A1	10/2002	Krupp et al.
7,299,082 B2	11/2007	Feldman et al.	2002/0161288 A1	10/2002	Shin et al.
7,310,544 B2	12/2007	Brister et al.	2002/0165462 A1	11/2002	Westbrook et al.
7,318,816 B2	1/2008	Bobroff et al.	2002/0169369 A1	11/2002	Ward et al.
7,324,012 B2	1/2008	Mann et al.	2002/0198444 A1	12/2002	Ughigaki et al.
7,329,239 B2	2/2008	Safabash et al.	2003/0023317 A1	1/2003	Brauker et al.
7,335,294 B2	2/2008	Heller et al.	2003/0023461 A1	1/2003	Quintanilla et al.
7,340,287 B2	3/2008	Mason et al.	2003/0032867 A1	2/2003	Crothall et al.
7,340,309 B2	3/2008	Miazga et al.	2003/0042137 A1	3/2003	Mao et al.
7,354,420 B2	4/2008	Steil et al.	2003/0060753 A1	3/2003	Starkweather et al.
7,364,592 B2	4/2008	Carr-Brendel et al.	2003/0065308 A1	4/2003	Lebel et al.
7,366,556 B2	4/2008	Brister et al.	2003/0069510 A1	4/2003	Semler
7,379,765 B2	5/2008	Petisce et al.	2003/0078481 A1	4/2003	McIvor et al.
7,381,184 B2	6/2008	Funderburk et al.	2003/0078560 A1	4/2003	Miller et al.
7,402,153 B2	7/2008	Steil et al.	2003/0083686 A1	5/2003	Freeman et al.
7,416,541 B2	8/2008	Yuzhakov et al.	2003/0097092 A1	5/2003	Flaherty
7,424,318 B2	9/2008	Brister et al.	2003/0100040 A1	5/2003	Bonnecaze et al.
7,455,663 B2	11/2008	Bikovsky	2003/0109775 A1	6/2003	O'Neil et al.
7,460,898 B2	12/2008	Brister et al.	2003/0134347 A1	7/2003	Heller et al.
7,467,003 B2	12/2008	Brister et al.	2003/0135333 A1	7/2003	Aceti et al.
7,471,972 B2	12/2008	Rhodes et al.	2003/0144581 A1	7/2003	Conn et al.
7,494,465 B2	2/2009	Brister et al.	2003/0144608 A1	7/2003	Kojima et al.
7,497,827 B2	3/2009	Brister et al.	2003/0155656 A1	8/2003	Chiu et al.
7,519,408 B2	4/2009	Rasdal et al.	2003/0168338 A1	9/2003	Gao et al.
7,583,990 B2	9/2009	Goode, Jr. et al.	2003/0176933 A1	9/2003	Lebel et al.
7,591,801 B2	9/2009	Brauker et al.	2003/0187338 A1	10/2003	Say et al.
7,599,726 B2	10/2009	Goode, Jr. et al.	2003/0199790 A1	10/2003	Boecker et al.
7,604,592 B2	10/2009	Freeman et al.	2003/0199910 A1	10/2003	Boecker et al.
7,613,491 B2	11/2009	Boock et al.	2003/0212379 A1	11/2003	Bylund et al.
7,615,007 B2	11/2009	Shults et al.	2003/0217966 A1	11/2003	Tapsak et al.
7,632,228 B2	12/2009	Brauker et al.	2003/0225361 A1	12/2003	Sabra
7,637,868 B2	12/2009	Saint et al.	2004/0002382 A1	1/2004	Kovelman et al.
7,640,048 B2	12/2009	Dobbles et al.	2004/0010207 A1	1/2004	Flaherty et al.
7,651,596 B2	1/2010	Petisce et al.	2004/0011671 A1	1/2004	Shults et al.
7,654,956 B2	2/2010	Brister et al.	2004/0040840 A1	3/2004	Mao et al.
7,657,297 B2	2/2010	Simpson et al.	2004/0045879 A1	3/2004	Shults et al.
			2004/0054263 A1	3/2004	Moerman et al.
			2004/0064068 A1	4/2004	DeNuzzio et al.
			2004/0064133 A1	4/2004	Miller et al.
			2004/0096959 A1	5/2004	Stiene et al.

(56)

References Cited

U.S. PATENT DOCUMENTS

2004/0106858	A1	6/2004	Say et al.	2006/0004303	A1	1/2006	Weidenhaupt et al.
2004/0106859	A1	6/2004	Say et al.	2006/0009727	A1	1/2006	O'Mahony et al.
2004/0116847	A1	6/2004	Wall	2006/0010098	A1	1/2006	Goodnow et al.
2004/0116865	A1	6/2004	Bengtsson	2006/0015020	A1	1/2006	Neale et al.
2004/0116866	A1	6/2004	Gorman et al.	2006/0015024	A1	1/2006	Brister et al.
2004/0122353	A1	6/2004	Shahmirian et al.	2006/0016700	A1	1/2006	Brister et al.
2004/0122489	A1	6/2004	Mazar et al.	2006/0019327	A1	1/2006	Brister et al.
2004/0133164	A1	7/2004	Funderbunk et al.	2006/0020186	A1	1/2006	Brister et al.
2004/0135684	A1	7/2004	Steinthal et al.	2006/0020187	A1	1/2006	Brister et al.
2004/0138544	A1	7/2004	Ward et al.	2006/0020188	A1	1/2006	Kamath et al.
2004/0138588	A1	7/2004	Saikley et al.	2006/0020189	A1	1/2006	Brister et al.
2004/0138688	A1	7/2004	Giraud	2006/0020190	A1	1/2006	Kamath et al.
2004/0147996	A1	7/2004	Miazga et al.	2006/0020191	A1	1/2006	Brister et al.
2004/0152622	A1	8/2004	Keith et al.	2006/0020192	A1	1/2006	Brister et al.
2004/0158207	A1	8/2004	Hunn et al.	2006/0036139	A1	2/2006	Brister et al.
2004/0167801	A1	8/2004	Say et al.	2006/0036140	A1	2/2006	Brister et al.
2004/0171910	A1	9/2004	Moore-Steele	2006/0036141	A1	2/2006	Kamath et al.
2004/0171921	A1	9/2004	Say et al.	2006/0036142	A1	2/2006	Brister et al.
2004/0176672	A1	9/2004	Silver et al.	2006/0036143	A1	2/2006	Brister et al.
2004/0186362	A1	9/2004	Brauker et al.	2006/0036144	A1	2/2006	Brister et al.
2004/0186365	A1	9/2004	Jin et al.	2006/0036145	A1	2/2006	Brister et al.
2004/0193090	A1	9/2004	Lebel et al.	2006/0047220	A1	3/2006	Sakata et al.
2004/0199059	A1	10/2004	Brauker et al.	2006/0081469	A1	4/2006	Lee
2004/0204687	A1	10/2004	Mogensen et al.	2006/0129173	A1	6/2006	Wilkinson
2004/0210122	A1	10/2004	Sleburg	2006/0155210	A1	7/2006	Beckman et al.
2004/0223985	A1	11/2004	Dunfield et al.	2006/0155317	A1	7/2006	List et al.
2004/0225338	A1	11/2004	Lebel et al.	2006/0166629	A1	7/2006	Reggiardo
2004/0236200	A1	11/2004	Say et al.	2006/0173444	A1	8/2006	Choy et al.
2004/0236251	A1	11/2004	Roe et al.	2006/0189863	A1	8/2006	Peysen et al.
2004/0254433	A1	12/2004	Bandis et al.	2006/0189939	A1	8/2006	Gonnelli et al.
2004/0254434	A1	12/2004	Goodnow et al.	2006/0195029	A1	8/2006	Shults et al.
2004/0267300	A1*	12/2004	Mace A61B 5/150022 606/182	2006/0200181	A1	9/2006	Fukuzawa et al.
2005/0003470	A1	1/2005	Nelson et al.	2006/0200970	A1	9/2006	Brister et al.
2005/0004494	A1	1/2005	Perez et al.	2006/0222566	A1	10/2006	Brauker et al.
2005/0006122	A1	1/2005	Burnette	2006/0224171	A1	10/2006	Sakata et al.
2005/0010269	A1	1/2005	Lebel et al.	2006/0226985	A1	10/2006	Goodnow et al.
2005/0027177	A1	2/2005	Shin et al.	2006/0247508	A1	11/2006	Fennell
2005/0027180	A1	2/2005	Goode, Jr. et al.	2006/0253086	A1	11/2006	Moberg et al.
2005/0031689	A1	2/2005	Shults et al.	2006/0258929	A1	11/2006	Goode, Jr. et al.
2005/0043598	A1	2/2005	Goode, Jr. et al.	2006/0264888	A1	11/2006	Moberg et al.
2005/0070819	A1	3/2005	Poux et al.	2006/0276724	A1	12/2006	Freeman et al.
2005/0085872	A1	4/2005	Yanagihara et al.	2006/0282042	A1	12/2006	Walters et al.
2005/0090607	A1	4/2005	Tapsak et al.	2006/0287591	A1	12/2006	Ocvirk et al.
2005/0090850	A1	4/2005	Thoes et al.	2007/0016381	A1	1/2007	Kamath et al.
2005/0106713	A1	5/2005	Phan et al.	2007/0027381	A1	2/2007	Stafford
2005/0112169	A1	5/2005	Brauker et al.	2007/0038044	A1	2/2007	Dobbles et al.
2005/0114068	A1	5/2005	Chey et al.	2007/0060814	A1	3/2007	Stafford
2005/0121322	A1	6/2005	Say et al.	2007/0073129	A1	3/2007	Shah et al.
2005/0131346	A1	6/2005	Douglas	2007/0078320	A1	4/2007	Stafford
2005/0143635	A1	6/2005	Kamath et al.	2007/0078321	A1	4/2007	Mazza et al.
2005/0154410	A1	7/2005	Conway et al.	2007/0078322	A1	4/2007	Stafford
2005/0165404	A1	7/2005	Miller	2007/0088377	A1	4/2007	Levaughn et al.
2005/0173245	A1	8/2005	Feldman et al.	2007/0106135	A1	5/2007	Sloan et al.
2005/0176136	A1	8/2005	Burd et al.	2007/0110124	A1	5/2007	Zaragoza et al.
2005/0182306	A1	8/2005	Sloan	2007/0123819	A1	5/2007	Mernoe et al.
2005/0187720	A1	8/2005	Goode, Jr. et al.	2007/0149875	A1	6/2007	Ouyang et al.
2005/0192557	A1	9/2005	Brauker et al.	2007/0156094	A1	7/2007	Safabash et al.
2005/0195930	A1	9/2005	Spital et al.	2007/0163880	A1	7/2007	Woo et al.
2005/0197554	A1	9/2005	Polcha	2007/0173706	A1	7/2007	Neinast et al.
2005/0199494	A1	9/2005	Say et al.	2007/0173741	A1	7/2007	Deshmukh et al.
2005/0203360	A1	9/2005	Brauker et al.	2007/0191701	A1	8/2007	Feldman et al.
2005/0222518	A1	10/2005	Dib	2007/0203407	A1	8/2007	Hoss et al.
2005/0222599	A1	10/2005	Czernecki et al.	2007/0203966	A1	8/2007	Brauker et al.
2005/0235156	A1	10/2005	Drucker et al.	2007/0213611	A1	9/2007	Simpson et al.
2005/0236277	A9	10/2005	Imran et al.	2007/0235331	A1	10/2007	Simpson et al.
2005/0239154	A1	10/2005	Feldman et al.	2007/0244368	A1	10/2007	Bayloff et al.
2005/0241957	A1	11/2005	Mao et al.	2007/0244398	A1	10/2007	Lo et al.
2005/0245795	A1	11/2005	Goode, Jr. et al.	2007/0249922	A1	10/2007	Peysen et al.
2005/0245799	A1	11/2005	Brauker et al.	2007/0255302	A1	11/2007	Koeppel et al.
2005/0245844	A1	11/2005	Mace et al.	2008/0004512	A1	1/2008	Funderburk et al.
2005/0277164	A1	12/2005	Drucker et al.	2008/0004573	A1	1/2008	Kaufmann et al.
2005/0283114	A1	12/2005	Bresina et al.	2008/0009692	A1	1/2008	Stafford
2005/0287620	A1	12/2005	Heller et al.	2008/0009805	A1	1/2008	Ethelfeld
2006/0001538	A1	1/2006	Kraft et al.	2008/0017522	A1	1/2008	Heller et al.
				2008/0021666	A1	1/2008	Goode, Jr. et al.
				2008/0027474	A1	1/2008	Curry et al.
				2008/0029391	A1	2/2008	Mao et al.
				2008/0033254	A1	2/2008	Kamath et al.
				2008/0033268	A1	2/2008	Stafford

(56)

References Cited

U.S. PATENT DOCUMENTS

2008/0033318	A1	2/2008	Mace et al.	2009/0062633	A1	3/2009	Brauker et al.
2008/0039702	A1	2/2008	Hayter et al.	2009/0062635	A1	3/2009	Brauker et al.
2008/0045824	A1	2/2008	Tapsak et al.	2009/0069658	A1	3/2009	Say et al.
2008/0064937	A1	3/2008	McGarraugh et al.	2009/0069750	A1	3/2009	Schraga
2008/0064941	A1	3/2008	Funderburk et al.	2009/0076356	A1	3/2009	Simpson et al.
2008/0064944	A1	3/2008	VanAntwerp et al.	2009/0076359	A1	3/2009	Peysner
2008/0065646	A1	3/2008	Zhang et al.	2009/0076360	A1	3/2009	Brister et al.
2008/0071156	A1	3/2008	Brister et al.	2009/0076361	A1	3/2009	Kamath et al.
2008/0083617	A1	4/2008	Simpson et al.	2009/0088614	A1	4/2009	Taub
2008/0086042	A1	4/2008	Brister et al.	2009/0088787	A1	4/2009	Koike et al.
2008/0086044	A1	4/2008	Brister et al.	2009/0099436	A1	4/2009	Brister et al.
2008/0086273	A1	4/2008	Shults et al.	2009/0102678	A1	4/2009	Mazza et al.
2008/0097246	A1*	4/2008	Stafford A61B 5/0002 600/584	2009/0105569	A1	4/2009	Stafford
2008/0108942	A1	5/2008	Brister et al.	2009/0124877	A1	5/2009	Shariati et al.
2008/0112848	A1	5/2008	Huffstodt et al.	2009/0124878	A1	5/2009	Goode, Jr. et al.
2008/0114280	A1	5/2008	Stafford	2009/0124879	A1	5/2009	Brister et al.
2008/0119707	A1	5/2008	Stafford	2009/0124964	A1	5/2009	Leach et al.
2008/0133702	A1	6/2008	Sharma et al.	2009/0124979	A1	5/2009	Raymond et al.
2008/0154205	A1	6/2008	Wojcik	2009/0131768	A1	5/2009	Simpson et al.
2008/0161664	A1	7/2008	Mastrototaro et al.	2009/0131769	A1	5/2009	Leach et al.
2008/0167578	A1	7/2008	Bryer et al.	2009/0131776	A1	5/2009	Simpson et al.
2008/0183061	A1	7/2008	Goode, Jr. et al.	2009/0131777	A1	5/2009	Simpson et al.
2008/0183399	A1	7/2008	Goode, Jr. et al.	2009/0131860	A1	5/2009	Nielson
2008/0188731	A1	8/2008	Brister et al.	2009/0137886	A1	5/2009	Shariati et al.
2008/0189051	A1	8/2008	Goode, Jr. et al.	2009/0137887	A1	5/2009	Shariati et al.
2008/0194935	A1	8/2008	Brister et al.	2009/0143659	A1	6/2009	Li et al.
2008/0194936	A1	8/2008	Goode, Jr. et al.	2009/0143660	A1	6/2009	Brister et al.
2008/0194937	A1	8/2008	Goode, Jr. et al.	2009/0156919	A1	6/2009	Brister et al.
2008/0194938	A1	8/2008	Brister et al.	2009/0156924	A1	6/2009	Shariati et al.
2008/0195049	A1	8/2008	Thalmann et al.	2009/0163790	A1	6/2009	Brister et al.
2008/0195232	A1	8/2008	Carr-Brendel et al.	2009/0163791	A1	6/2009	Brister et al.
2008/0195967	A1	8/2008	Goode, Jr. et al.	2009/0171182	A1	7/2009	Stafford
2008/0197024	A1	8/2008	Simpson et al.	2009/0178459	A1	7/2009	Li et al.
2008/0200788	A1	8/2008	Brister et al.	2009/0182217	A1	7/2009	Li et al.
2008/0200789	A1	8/2008	Brister et al.	2009/0192366	A1	7/2009	Mensingher et al.
2008/0200791	A1	8/2008	Simpson et al.	2009/0192380	A1	7/2009	Shariati et al.
2008/0200897	A1	8/2008	Hoss et al.	2009/0192722	A1	7/2009	Shariati et al.
2008/0208025	A1	8/2008	Shults et al.	2009/0192724	A1	7/2009	Brauker et al.
2008/0214481	A1	9/2008	Challoner et al.	2009/0192745	A1	7/2009	Kamath et al.
2008/0214915	A1	9/2008	Brister et al.	2009/0192751	A1	7/2009	Kamath et al.
2008/0214918	A1	9/2008	Brister et al.	2009/0198215	A1	8/2009	Chong et al.
2008/0228051	A1	9/2008	Shults et al.	2009/0203981	A1	8/2009	Brauker et al.
2008/0228054	A1	9/2008	Shults et al.	2009/0204341	A1	8/2009	Brauker et al.
2008/0242961	A1	10/2008	Brister et al.	2009/0212766	A1	8/2009	Olson et al.
2008/0255440	A1	10/2008	Eilersen et al.	2009/0216103	A1	8/2009	Brister et al.
2008/0262469	A1	10/2008	Brister et al.	2009/0240120	A1	9/2009	Mensingher et al.
2008/0269673	A1	10/2008	Butoi et al.	2009/0240128	A1	9/2009	Mensingher et al.
2008/0275313	A1	11/2008	Brister et al.	2009/0240193	A1	9/2009	Mensingher et al.
2008/0283396	A1	11/2008	Wang et al.	2009/0242399	A1	10/2009	Kamath et al.
2008/0287764	A1	11/2008	Rasdal et al.	2009/0242425	A1	10/2009	Kamath et al.
2008/0287765	A1	11/2008	Rasdal et al.	2009/0247855	A1	10/2009	Boock et al.
2008/0287766	A1	11/2008	Rasdal et al.	2009/0247856	A1	10/2009	Boock et al.
2008/0294096	A1	11/2008	Uber et al.	2009/0259118	A1	10/2009	Feldman et al.
2008/0296155	A1	12/2008	Shults et al.	2009/0259201	A1	10/2009	Hwang et al.
2008/0300476	A1	12/2008	Stafford	2009/0259202	A1	10/2009	Leefflang et al.
2008/0306368	A1	12/2008	Goode, Jr. et al.	2009/0270765	A1	10/2009	Ghesquire et al.
2008/0306434	A1	12/2008	Dobbles et al.	2009/0287073	A1	11/2009	Boock et al.
2008/0306435	A1	12/2008	Kamath et al.	2009/0287074	A1	11/2009	Shults et al.
2008/0306444	A1	12/2008	Brister et al.	2009/0292184	A1	11/2009	Funderburk et al.
2009/0005659	A1	1/2009	Kollias et al.	2009/0292185	A1	11/2009	Funderburk et al.
2009/0012377	A1	1/2009	Jennewine et al.	2009/0299155	A1	12/2009	Yang et al.
2009/0012379	A1	1/2009	Goode, Jr. et al.	2009/0299156	A1	12/2009	Simpson et al.
2009/0018424	A1	1/2009	Kamath et al.	2009/0299162	A1	12/2009	Brauker et al.
2009/0030294	A1	1/2009	Petisce et al.	2009/0299167	A1	12/2009	Seymour
2009/0036758	A1	2/2009	Brauker et al.	2009/0299276	A1	12/2009	Brauker et al.
2009/0036763	A1	2/2009	Brauker et al.	2010/0004597	A1	1/2010	Gryn et al.
2009/0036915	A1	2/2009	Karbowniczek et al.	2010/0010324	A1	1/2010	Brauker et al.
2009/0043181	A1	2/2009	Brauker et al.	2010/0010331	A1	1/2010	Brauker et al.
2009/0043182	A1	2/2009	Brauker et al.	2010/0010332	A1	1/2010	Brauker et al.
2009/0043525	A1	2/2009	Brauker et al.	2010/0016687	A1	1/2010	Brauker et al.
2009/0043541	A1	2/2009	Brauker et al.	2010/0016698	A1	1/2010	Rasdal et al.
2009/0043542	A1	2/2009	Brauker et al.	2010/0022855	A1	1/2010	Brauker et al.
2009/0045055	A1	2/2009	Rhodes et al.	2010/0022863	A1	1/2010	Mogensen et al.
2009/0054866	A1	2/2009	Teisen-Simony et al.	2010/0030038	A1	2/2010	Brauker et al.
				2010/0030053	A1	2/2010	Goode, Jr. et al.
				2010/0030484	A1	2/2010	Brauker et al.
				2010/0030485	A1	2/2010	Brauker et al.
				2010/0036215	A1	2/2010	Goode, Jr. et al.
				2010/0036216	A1	2/2010	Goode, Jr. et al.

(56)

References Cited

U.S. PATENT DOCUMENTS

2010/0036222	A1	2/2010	Goode, Jr. et al.	2011/0021889	A1	1/2011	Hoss et al.
2010/0036223	A1	2/2010	Goode, Jr. et al.	2011/0024043	A1	2/2011	Boock et al.
2010/0036225	A1	2/2010	Goode, Jr. et al.	2011/0024307	A1	2/2011	Simpson et al.
2010/0036281	A1	2/2010	Doi	2011/0027127	A1	2/2011	Simpson et al.
2010/0041971	A1	2/2010	Goode, Jr. et al.	2011/0027453	A1	2/2011	Boock et al.
2010/0045465	A1	2/2010	Brauker et al.	2011/0027458	A1	2/2011	Boock et al.
2010/0049014	A1	2/2010	Funderburk et al.	2011/0028815	A1	2/2011	Simpson et al.
2010/0049024	A1	2/2010	Saint et al.	2011/0028816	A1	2/2011	Simpson et al.
2010/0063373	A1	3/2010	Kamath et al.	2011/0040256	A1	2/2011	Bobroff et al.
2010/0076283	A1	3/2010	Simpson et al.	2011/0040263	A1	2/2011	Hordum et al.
2010/0081908	A1	4/2010	Dobbles et al.	2011/0046456	A1	2/2011	Hordum et al.
2010/0081910	A1	4/2010	Brister et al.	2011/0046467	A1	2/2011	Simpson et al.
2010/0087724	A1	4/2010	Brauker et al.	2011/0054275	A1	3/2011	Stafford
2010/0096259	A1	4/2010	Zhang et al.	2011/0060196	A1	3/2011	Stafford
2010/0099970	A1	4/2010	Shults et al.	2011/0073475	A1	3/2011	Kastanos et al.
2010/0099971	A1	4/2010	Shults et al.	2011/0077490	A1	3/2011	Simpson et al.
2010/0106088	A1	4/2010	Yodfat et al.	2011/0082484	A1	4/2011	Saravia et al.
2010/0113894	A1	5/2010	Brenneman et al.	2011/0106126	A1	5/2011	Love et al.
2010/0119693	A1	5/2010	Tapsak et al.	2011/0118579	A1	5/2011	Goode, Jr. et al.
2010/0121169	A1	5/2010	Petisce et al.	2011/0118580	A1	5/2011	Goode, Jr. et al.
2010/0168677	A1	7/2010	Gabriel et al.	2011/0124992	A1	5/2011	Brauker et al.
2010/0174157	A1	7/2010	Brister et al.	2011/0124997	A1	5/2011	Goode, Jr. et al.
2010/0174158	A1	7/2010	Kamath et al.	2011/0125410	A1	5/2011	Goode, Jr. et al.
2010/0174163	A1	7/2010	Brister et al.	2011/0130970	A1	6/2011	Goode, Jr. et al.
2010/0174164	A1	7/2010	Brister et al.	2011/0130971	A1	6/2011	Goode, Jr. et al.
2010/0174165	A1	7/2010	Brister et al.	2011/0130998	A1	6/2011	Goode, Jr. et al.
2010/0174166	A1	7/2010	Brister et al.	2011/0137257	A1	6/2011	Gyrn et al.
2010/0174167	A1	7/2010	Kamath et al.	2011/0144465	A1	6/2011	Shults et al.
2010/0174168	A1	7/2010	Goode, Jr. et al.	2011/0178378	A1	7/2011	Brister et al.
2010/0179401	A1	7/2010	Rasdal et al.	2011/0178461	A1	7/2011	Chong et al.
2010/0179402	A1	7/2010	Goode, Jr. et al.	2011/0184258	A1	7/2011	Stafford
2010/0179404	A1	7/2010	Kamath et al.	2011/0190603	A1	8/2011	Stafford
2010/0179408	A1	7/2010	Kamath et al.	2011/0190614	A1	8/2011	Brister et al.
2010/0179409	A1	7/2010	Kamath et al.	2011/0191044	A1*	8/2011	Stafford A61B 5/0002 702/65
2010/0185065	A1	7/2010	Goode, Jr. et al.	2011/0201910	A1	8/2011	Rasdal et al.
2010/0186069	A1	7/2010	Brister et al.	2011/0201911	A1	8/2011	Johnson et al.
2010/0186070	A1	7/2010	Brister et al.	2011/0218414	A1	9/2011	Kamath et al.
2010/0186071	A1	7/2010	Simpson et al.	2011/0231107	A1	9/2011	Brauker et al.
2010/0186072	A1	7/2010	Goode, Jr. et al.	2011/0231140	A1	9/2011	Goode, Jr. et al.
2010/0186075	A1	7/2010	Brister et al.	2011/0231141	A1	9/2011	Goode, Jr. et al.
2010/0191082	A1	7/2010	Brister et al.	2011/0231142	A1	9/2011	Goode, Jr. et al.
2010/0198033	A1	8/2010	Krulevitch et al.	2011/0253533	A1	10/2011	Shults et al.
2010/0198034	A1	8/2010	Thomas et al.	2011/0257521	A1	10/2011	Fraden
2010/0198035	A1	8/2010	Kamath et al.	2011/0257895	A1	10/2011	Brauker et al.
2010/0198036	A1	8/2010	Kamath et al.	2011/0263958	A1	10/2011	Brauker et al.
2010/0204653	A1	8/2010	Gryn et al.	2011/0270062	A1	11/2011	Goode, Jr. et al.
2010/0212583	A1	8/2010	Brister et al.	2011/0270158	A1	11/2011	Brauker et al.
2010/0214104	A1	8/2010	Goode, Jr. et al.	2011/0275919	A1	11/2011	Petisce et al.
2010/0217105	A1	8/2010	Yodfat et al.	2011/0288574	A1*	11/2011	Curry A61B 5/15194 606/185
2010/0217557	A1	8/2010	Kamath et al.	2011/0290645	A1	12/2011	Brister et al.
2010/0223013	A1	9/2010	Kamath et al.	2011/0313543	A1	12/2011	Brauker et al.
2010/0223022	A1	9/2010	Kamath et al.	2011/0319729	A1	12/2011	Donnay et al.
2010/0223023	A1	9/2010	Kamath et al.	2011/0319733	A1	12/2011	Stafford
2010/0228109	A1	9/2010	Kamath et al.	2011/0319738	A1	12/2011	Woodruff et al.
2010/0228497	A1	9/2010	Kamath et al.	2011/0319739	A1	12/2011	Kamath et al.
2010/0240975	A1	9/2010	Goode, Jr. et al.	2011/0320130	A1	12/2011	Valdes et al.
2010/0240976	A1	9/2010	Goode, Jr. et al.	2012/0010642	A1	1/2012	Lee et al.
2010/0256471	A1	10/2010	Say et al.	2012/0035445	A1	2/2012	Boock et al.
2010/0261987	A1	10/2010	Kamath et al.	2012/0040101	A1	2/2012	Tapsak et al.
2010/0262201	A1	10/2010	He et al.	2012/0046534	A1	2/2012	Simpson et al.
2010/0274107	A1	10/2010	Boock et al.	2012/0078071	A1	3/2012	Bohm et al.
2010/0280341	A1	11/2010	Boock et al.	2012/0108934	A1	5/2012	Valdes et al.
2010/0286496	A1	11/2010	Simpson et al.	2012/0108983	A1	5/2012	Banet et al.
2010/0298684	A1	11/2010	Leach et al.	2012/0123385	A1	5/2012	Edwards et al.
2010/0324392	A1	12/2010	Yee et al.	2012/0143135	A1	6/2012	Cole et al.
2010/0324403	A1	12/2010	Brister et al.	2012/0184909	A1	7/2012	Gyrn et al.
2010/0331642	A1	12/2010	Bruce et al.	2012/0296327	A1	11/2012	Hutchins et al.
2010/0331644	A1	12/2010	Neale et al.	2012/0323098	A1*	12/2012	Moein A61B 5/6848 600/345
2010/0331647	A1	12/2010	Shah et al.	2013/0047981	A1	2/2013	Bacon
2010/0331648	A1	12/2010	Kamath et al.	2013/0150691	A1*	6/2013	Pace A61B 5/14532 600/347
2010/0331653	A1	12/2010	Stafford	2015/0190075	A1*	7/2015	Stafford A61B 5/14532 29/407.1
2010/0331656	A1	12/2010	Mensingher et al.	2015/0341438	A1*	11/2015	Sloan A61B 5/0004 455/41.2
2010/0331657	A1	12/2010	Mensingher et al.				
2011/0004085	A1	1/2011	Mensingher et al.				
2011/0009727	A1	1/2011	Mensingher et al.				

(56)

References Cited

U.S. PATENT DOCUMENTS

2016/0015303 A1* 1/2016 Bernstein G06Q 50/22
600/347
2016/0331284 A1* 11/2016 Pace A61B 5/14503
2017/0020456 A1* 1/2017 Pace A61B 5/6833
2019/0021636 A1* 1/2019 Walter A61B 5/6849
2019/0083017 A1* 3/2019 Walter A61B 5/6849

FOREIGN PATENT DOCUMENTS

DE 4401400 7/1995
EP 0320109 6/1989
EP 0353328 2/1990
EP 0390390 10/1990
EP 0396788 11/1990
EP 0286118 1/1995
EP 1048264 11/2000
EP 1177802 2/2002
EP 0987982 1/2007
EP 2060284 5/2009
EP 2201969 6/2010
EP 2327362 6/2011
EP 2335587 6/2011
JP 11-506629 6/1999
JP 2004-520103 7/2004
JP 2004/520898 7/2004
WO WO-1991/015993 10/1991
WO WO-1992/013271 8/1992
WO WO-1994/020602 9/1994
WO WO-1996/025089 8/1996
WO WO-1998/035053 8/1998
WO WO-1998/056293 12/1998

WO WO-1999/033504 7/1999
WO WO-1999/056613 11/1999
WO WO-2000/049940 8/2000
WO WO-2000/059370 10/2000
WO WO-2000/078992 12/2000
WO WO-2001/052935 7/2001
WO WO-2001/054753 8/2001
WO WO-2002/016905 2/2002
WO WO-2002/050534 6/2002
WO WO-2002/058537 8/2002
WO WO-2003/028784 4/2003
WO WO-2003/076893 9/2003
WO WO-2003/082091 10/2003
WO WO-2004/028337 4/2004
WO WO-2004/060436 7/2004
WO WO-2004/061420 7/2004
WO WO-2004/098684 11/2004
WO WO-2004/112602 12/2004
WO WO-2005/084534 9/2005
WO WO-2005/089103 9/2005
WO WO-2006/024671 3/2006
WO WO-2006/042811 4/2006
WO WO-2006/108809 10/2006
WO WO-2007/002189 1/2007
WO WO-2007/089738 8/2007
WO WO-2007/140783 12/2007
WO WO-2008/014792 2/2008
WO WO-2008/065646 6/2008
WO WO-2008/133702 11/2008
WO WO-2009/062675 5/2009
WO WO-2009/068661 6/2009
WO WO-2010/112521 10/2010
WO WO-2011/002815 1/2011
WO WO-2011/015659 2/2011

* cited by examiner

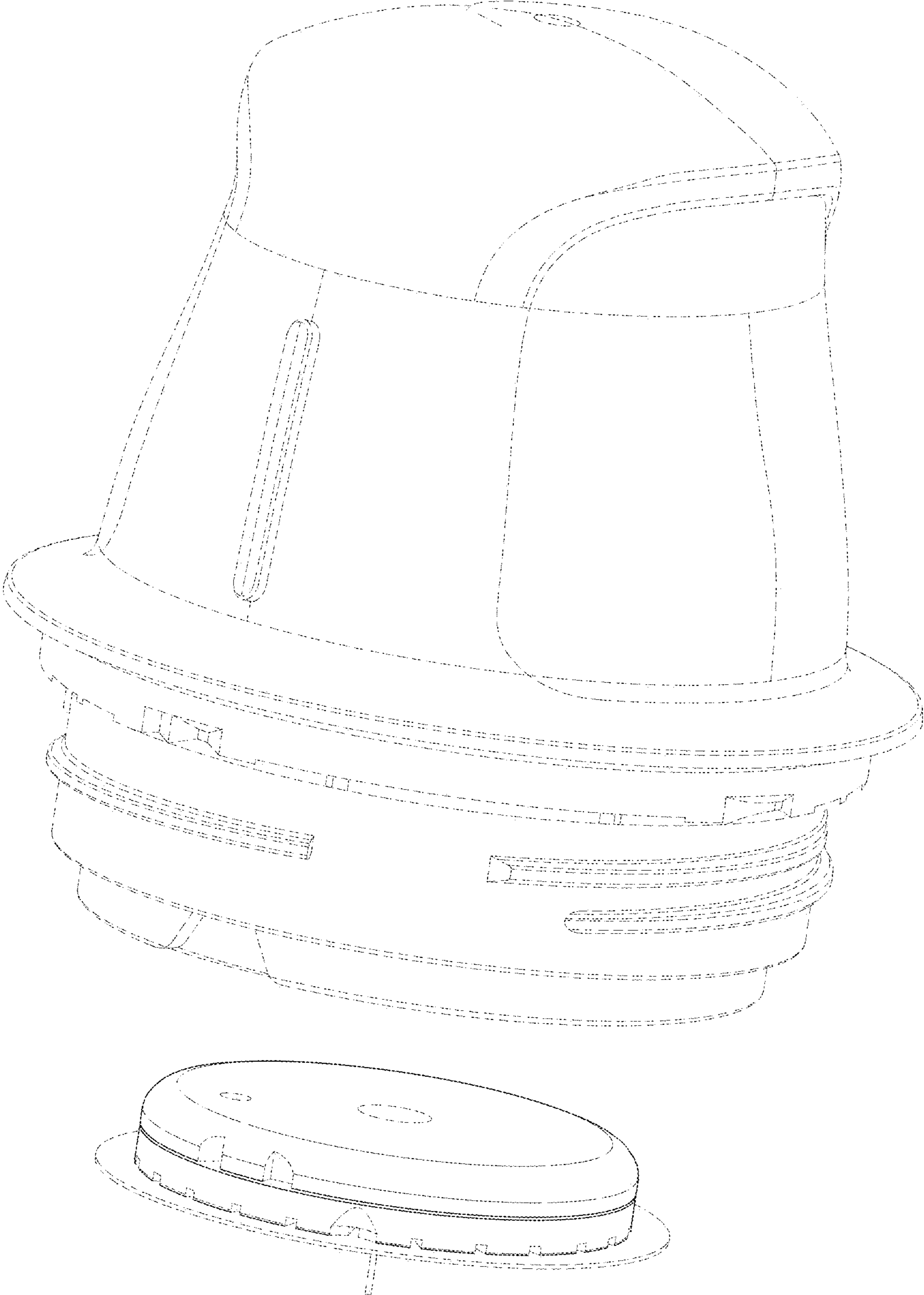

FIG. 1

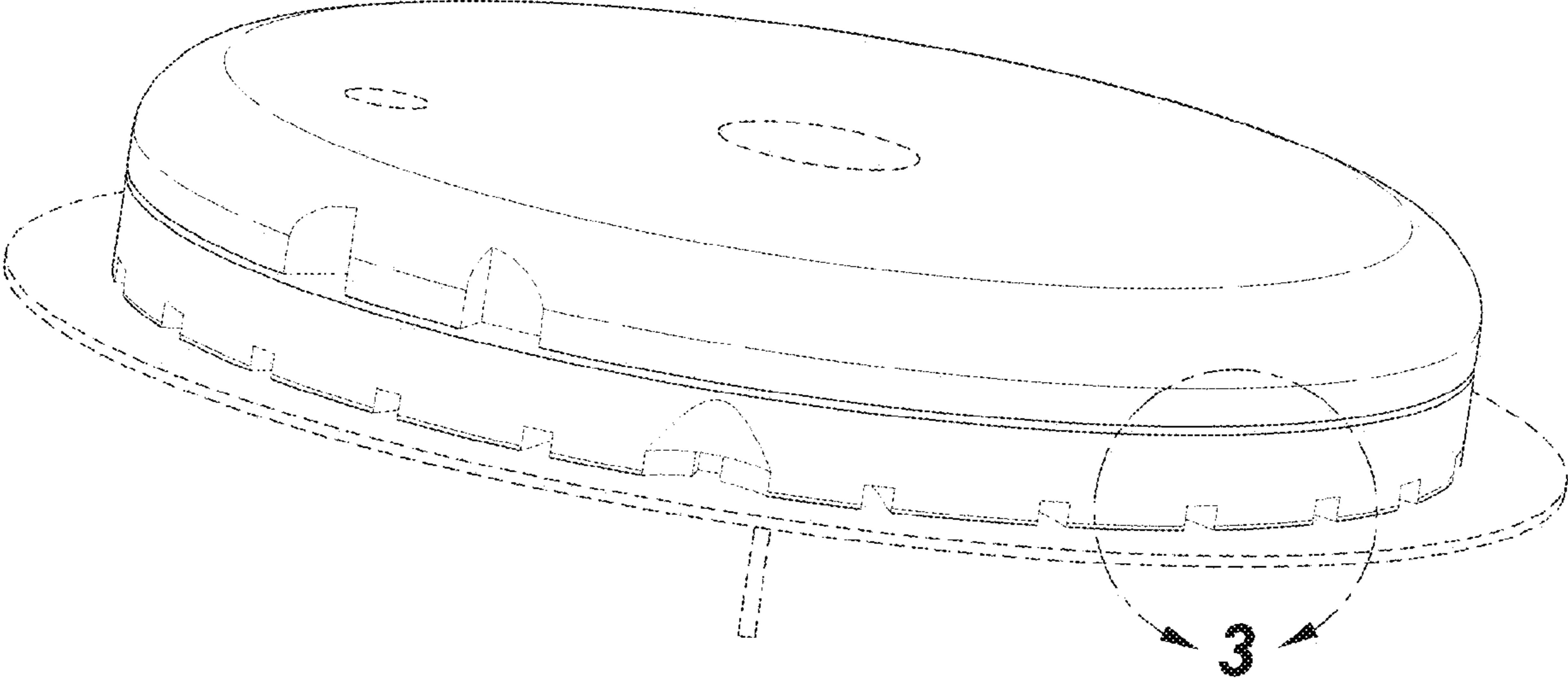

FIG. 2

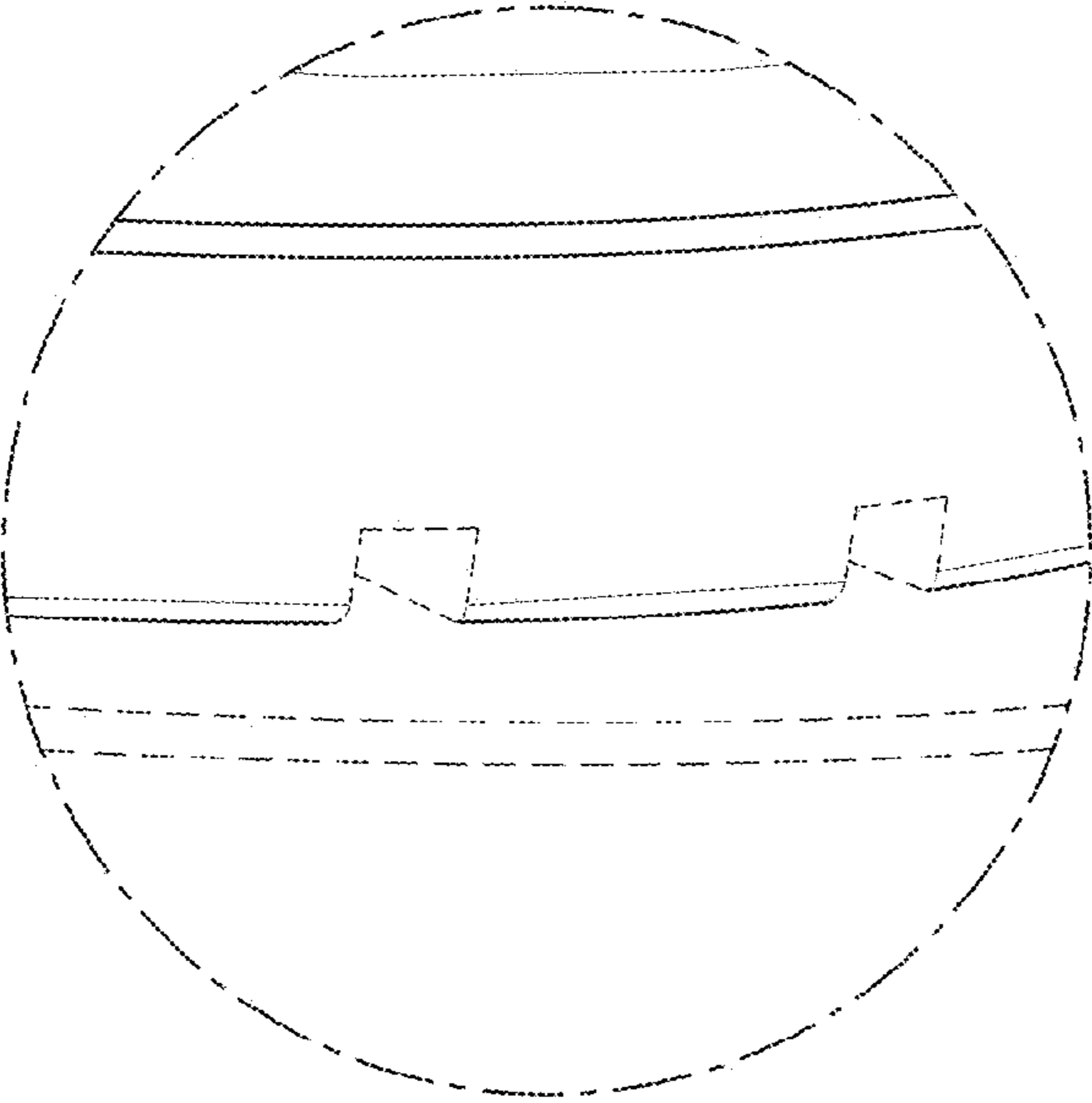

FIG. 3

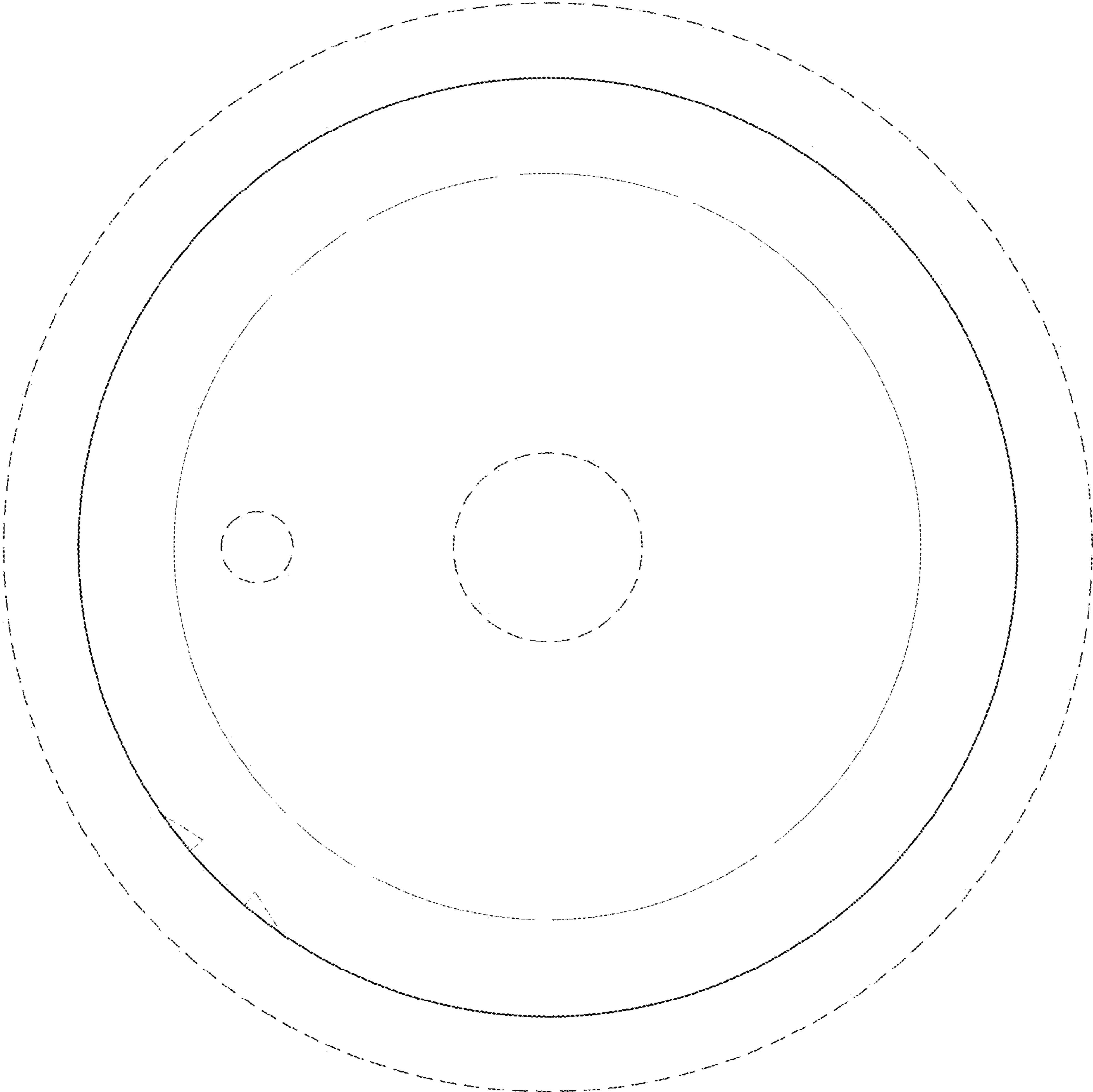

FIG. 4

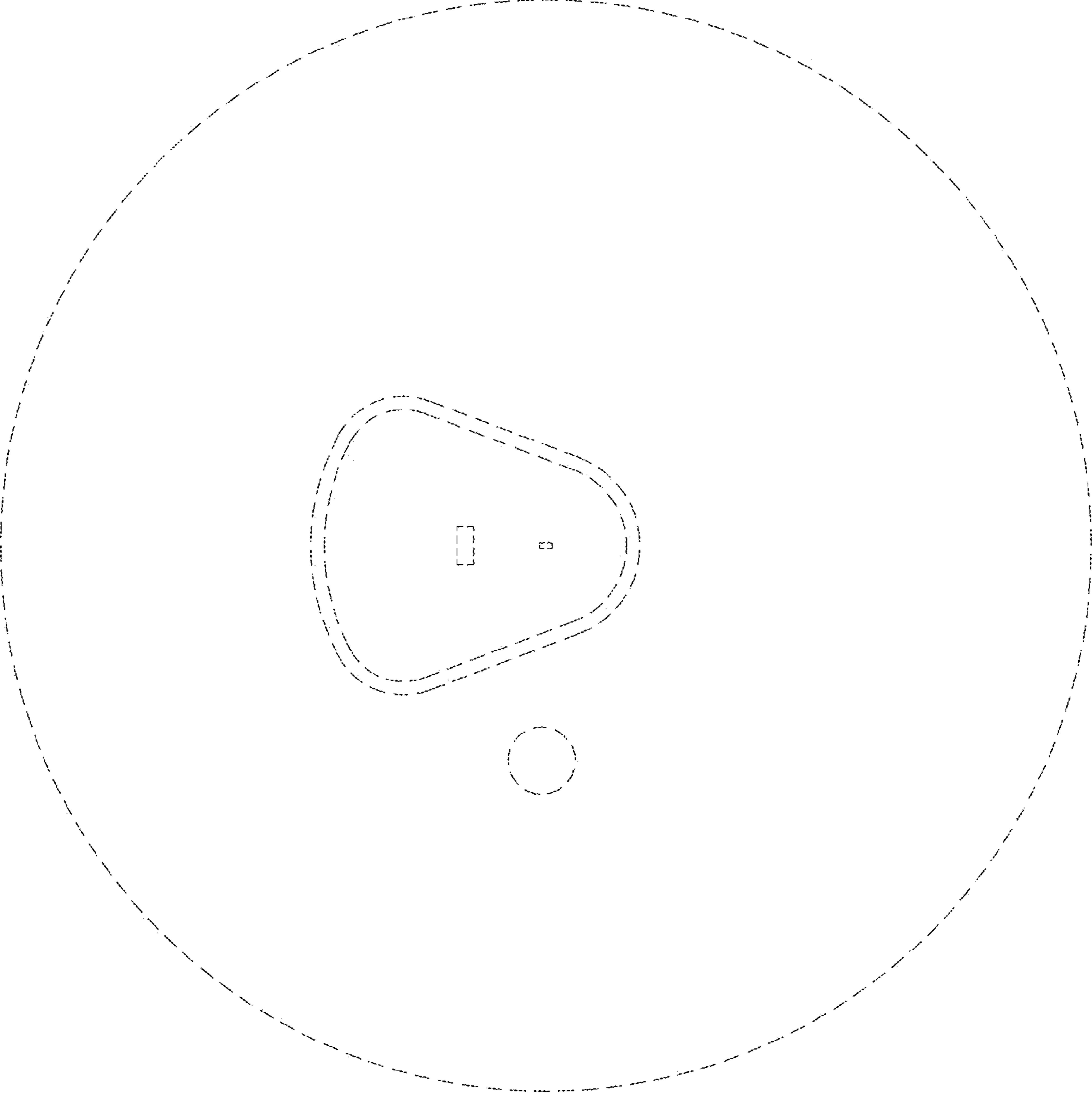

FIG. 5

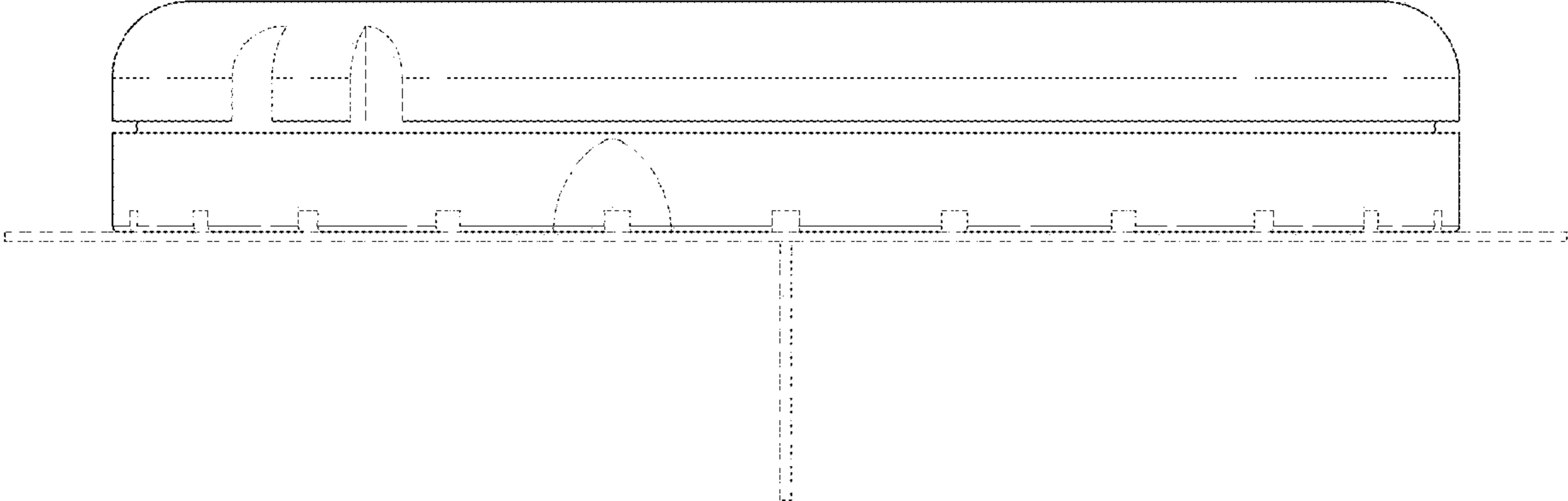

FIG. 6

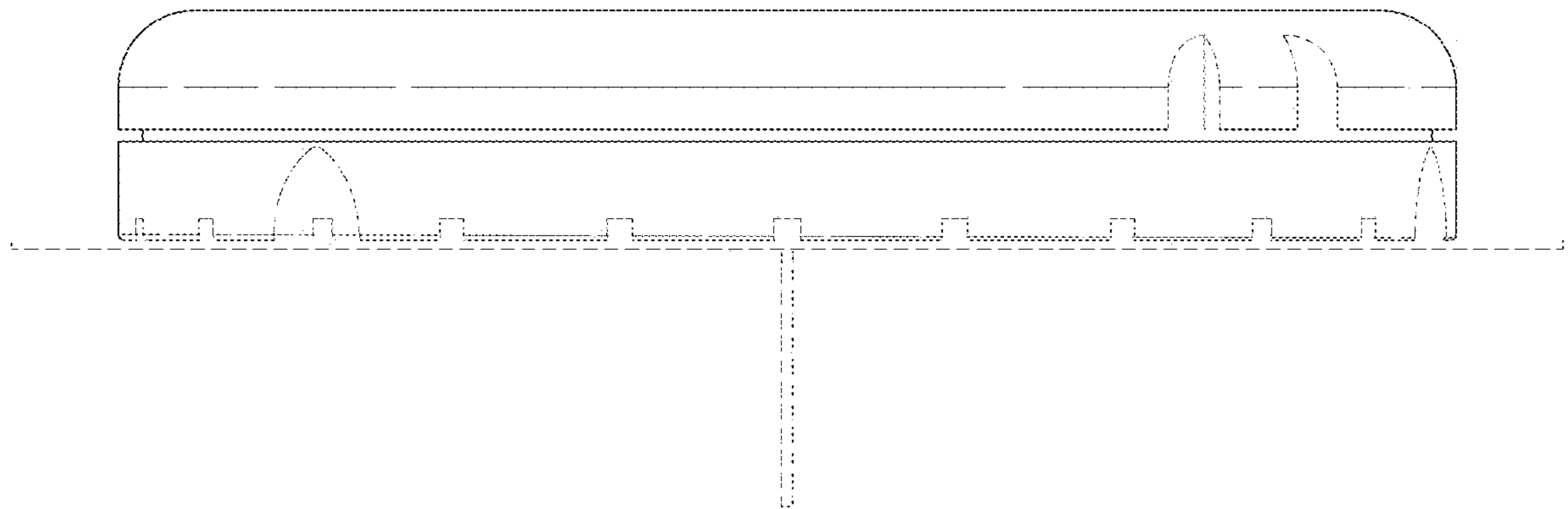

FIG. 7

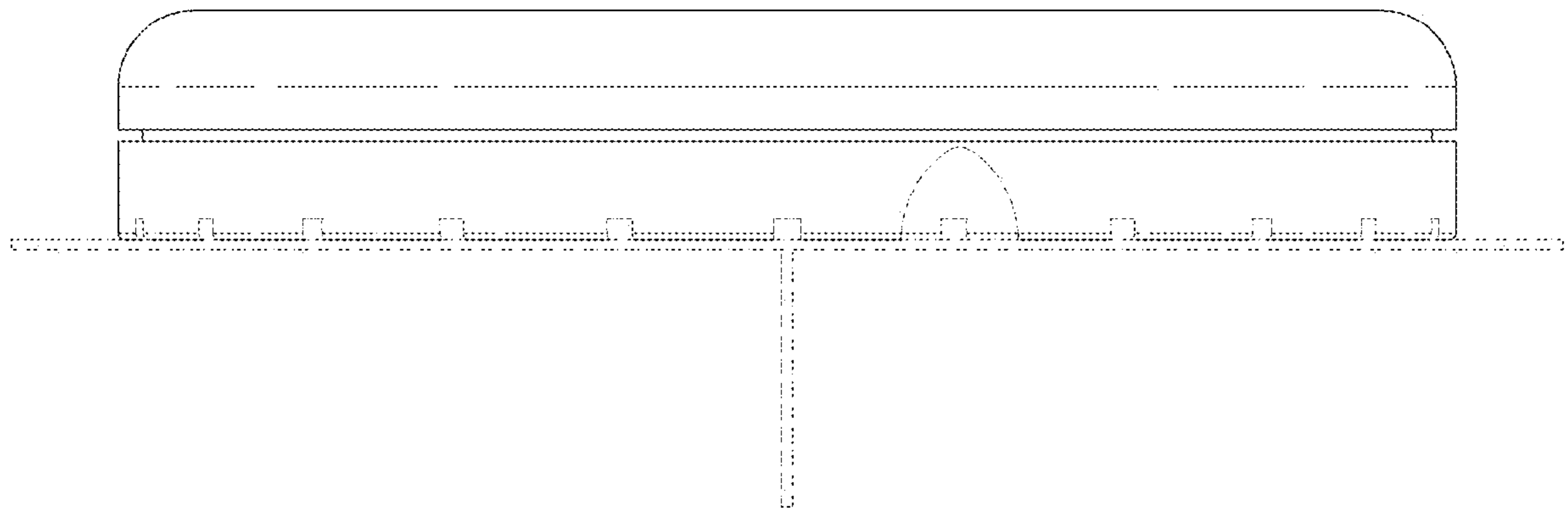

FIG. 8

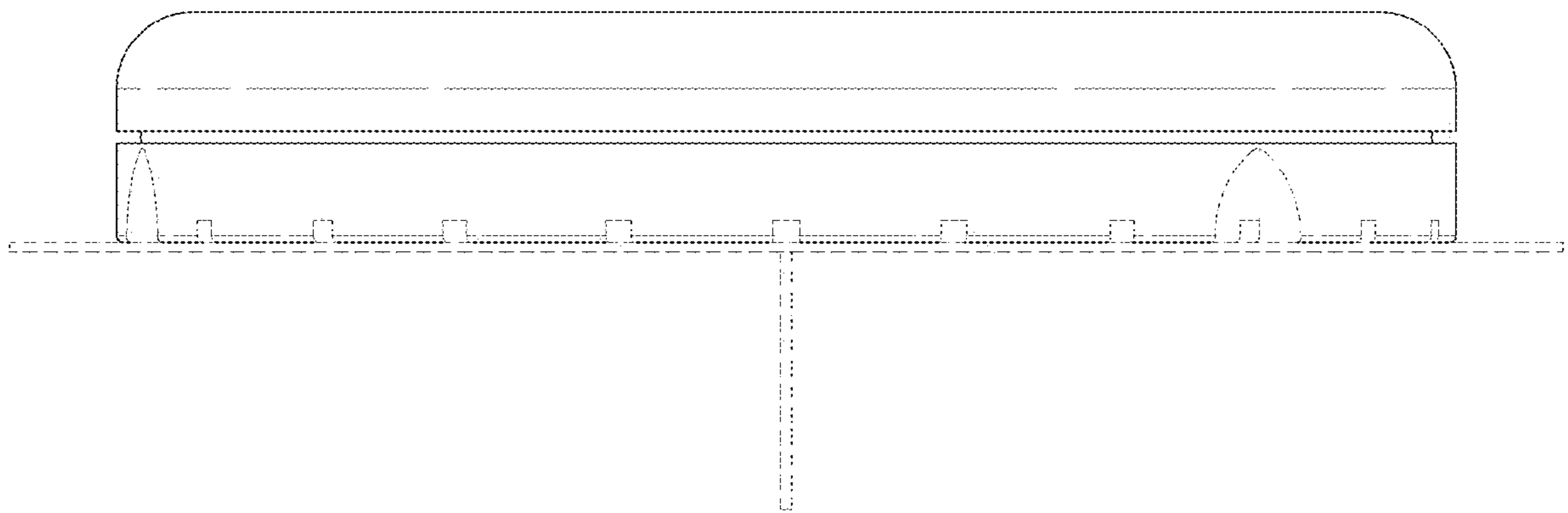

FIG. 9