



US00D903537S

(12) **United States Design Patent** (10) **Patent No.:** **US D903,537 S**  
**DeBaker et al.** (45) **Date of Patent:** **\*\* Dec. 1, 2020**

(54) **BICYCLE RACK**  
(71) Applicants: **Chad DeBaker**, Minneapolis, MN  
(US); **James Schwalbe**, Minneapolis,  
MN (US)  
(72) Inventors: **Chad DeBaker**, Minneapolis, MN  
(US); **James Schwalbe**, Minneapolis,  
MN (US)  
(\*\*) Term: **15 Years**  
(21) Appl. No.: **29/697,250**  
(22) Filed: **Jul. 5, 2019**  
(51) **LOC (12) Cl.** ..... **08-10**  
(52) **U.S. Cl.**  
USPC ..... **D12/115**  
(58) **Field of Classification Search**  
USPC ..... D12/115, 120, 402, 406-408; D25/41.1,  
D25/38.1, 119, 121; D8/354  
CPC ... B62H 3/00; B62H 3/04; B62H 3/08; B62H  
3/10; B60R 9/06; B60R 9/10  
See application file for complete search history.

D595,189 S \* 6/2009 Palmer ..... D12/115  
D605,093 S \* 12/2009 Lohr ..... D12/115  
D623,095 S \* 9/2010 Nusbaum ..... D12/115  
D623,991 S \* 9/2010 Nusbaum ..... D12/115  
D632,616 S \* 2/2011 Lohr ..... D12/115  
D679,629 S \* 4/2013 Davenport ..... D12/115  
D697,837 S \* 1/2014 Kirn ..... D12/115  
D719,491 S \* 12/2014 Rayl ..... D12/115  
D719,492 S \* 12/2014 Rayl ..... D12/115  
D735,091 S \* 7/2015 Slaughenhaupt ..... D12/115  
D778,788 S \* 2/2017 Tsai ..... D12/115  
D796,387 S \* 9/2017 Lee ..... D12/115  
D841,523 S \* 2/2019 Ford ..... D12/115  
2004/0251219 A1 \* 12/2004 Zimmerman ..... B62H 3/08  
211/17

\* cited by examiner

*Primary Examiner* — Michelle E. Wilson  
*Assistant Examiner* — Clese Moore, Jr.  
(74) *Attorney, Agent, or Firm* — Quickpatents, LLC;  
Kevin Prince

(57) **CLAIM**

The ornamental design for a bicycle rack, as shown and described.

**DESCRIPTION**

FIG. 1 is a top front perspective view of a bicycle rack, showing our new design;  
FIG. 2 is a bottom perspective view thereof;  
FIG. 3 is a front elevational view thereof the rear elevational view being a mirror image thereof;  
FIG. 4 is a top plan view thereof,  
FIG. 5 is a bottom plan view thereof;  
FIG. 6 is an enlarged left-side elevational view thereof; and,  
FIG. 7 is an enlarged right-side elevational view thereof.  
The broken lines shown illustrate portions of the bicycle rack that form no part of the claimed design.

**1 Claim, 5 Drawing Sheets**

(56) **References Cited**  
U.S. PATENT DOCUMENTS  
D245,596 S \* 8/1977 Cohen ..... D12/115  
D301,217 S \* 5/1989 Mailhot ..... D12/115  
D302,803 S \* 8/1989 Villanueva ..... D12/115  
D302,804 S \* 8/1989 Mailhot ..... D12/115  
D328,882 S \* 8/1992 Martinell ..... D12/115  
D369,576 S \* 5/1996 Johnson ..... D12/115  
D391,529 S \* 3/1998 Skalka ..... D12/115  
D408,764 S \* 4/1999 Graber ..... D12/115  
D480,350 S \* 10/2003 Ho ..... D12/408  
D514,034 S \* 1/2006 Richardson ..... D12/115  
D519,062 S \* 4/2006 Hartger ..... D12/115  
D591,649 S \* 5/2009 Koshes ..... D12/115

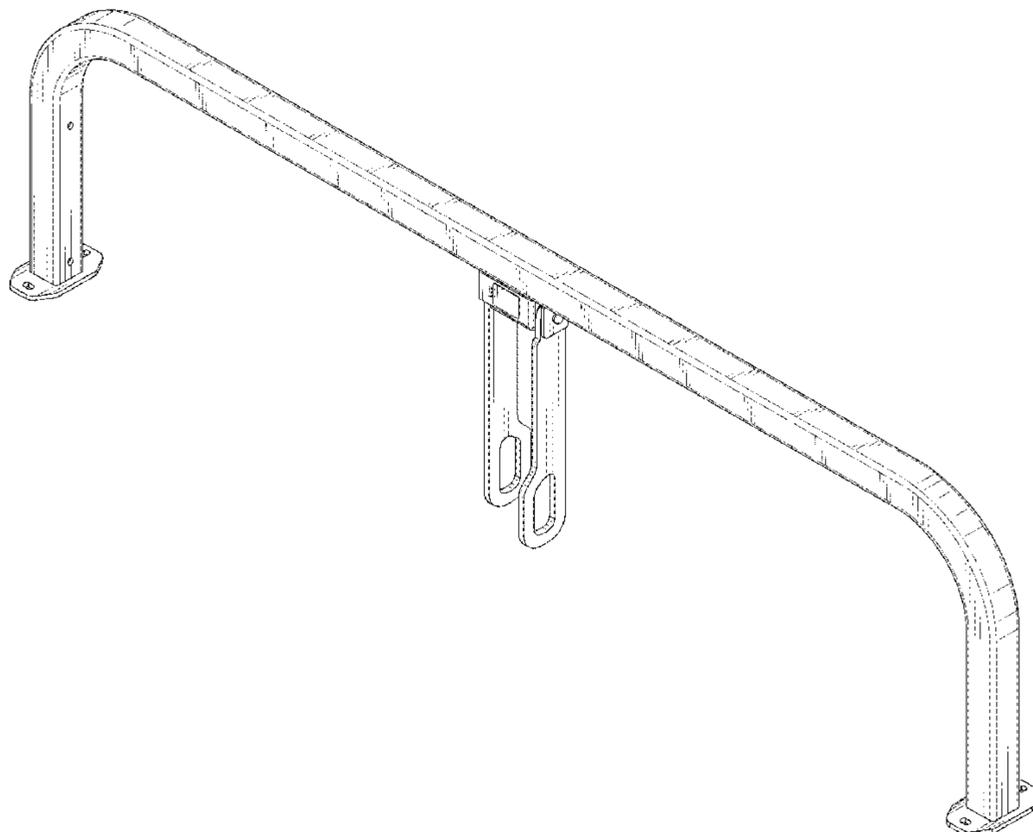

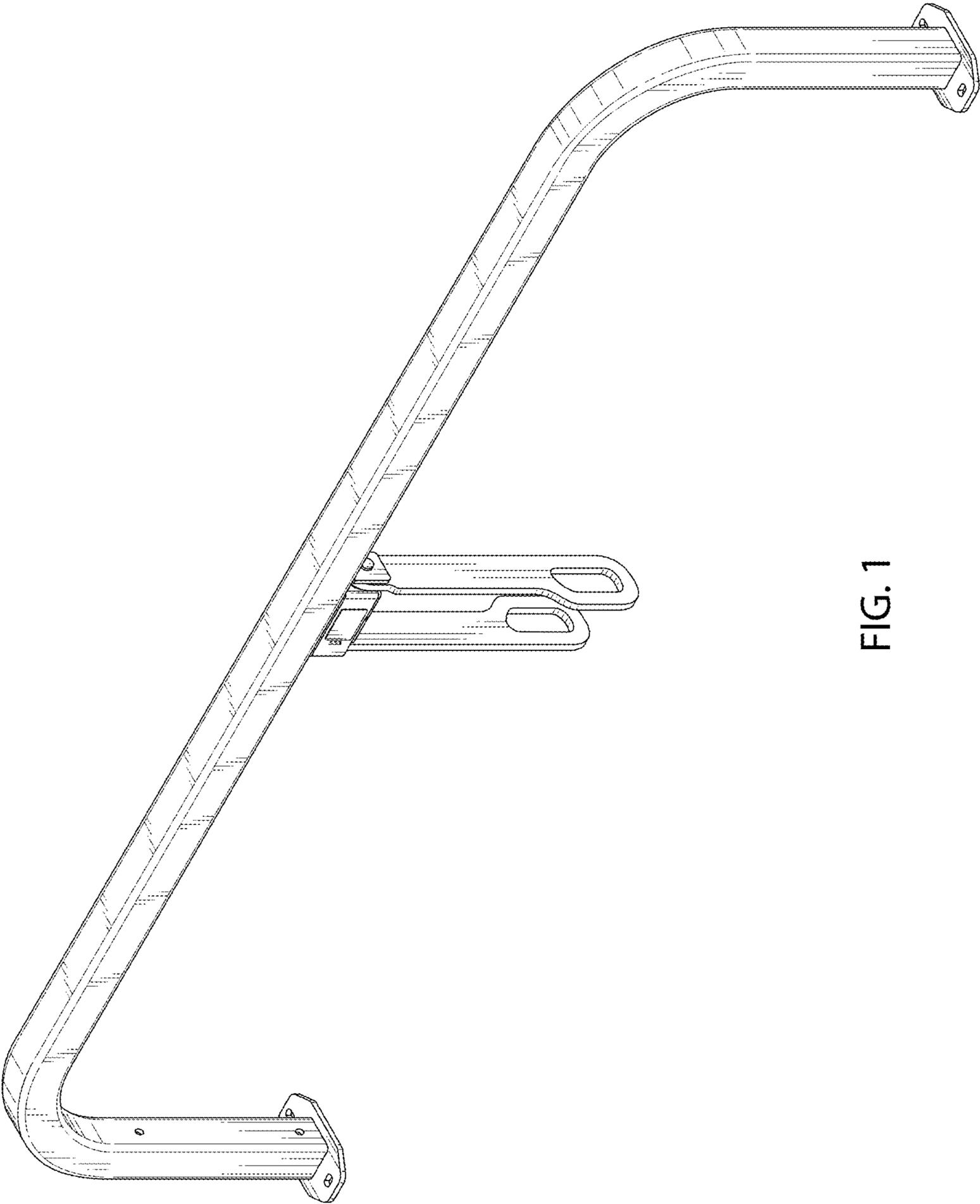

FIG. 1

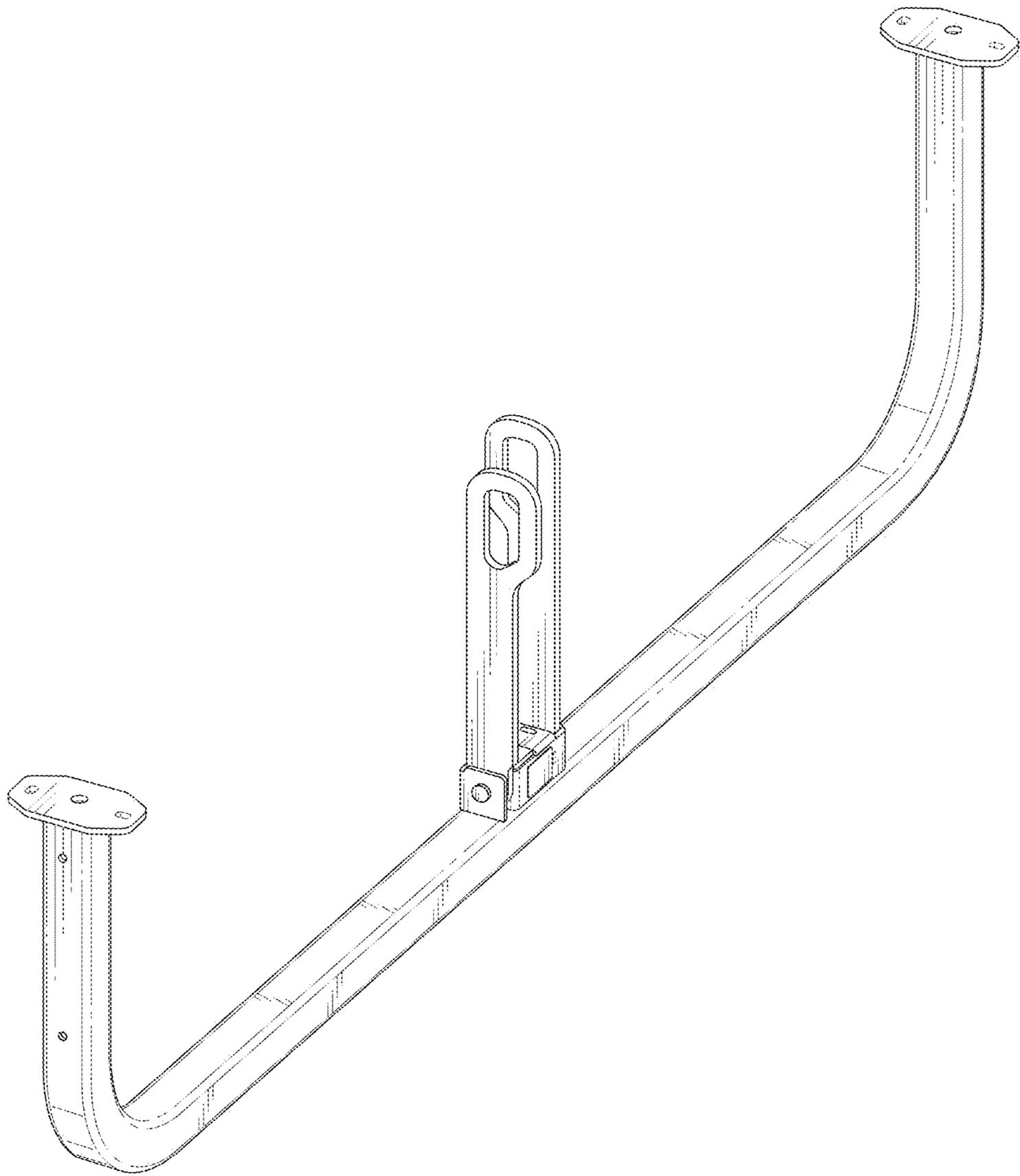

FIG. 2

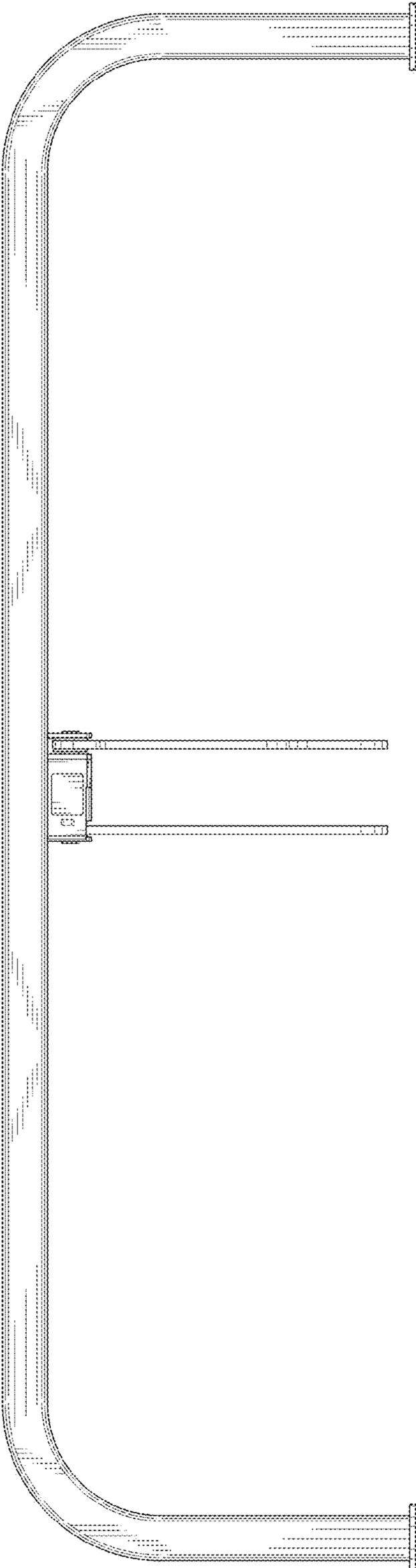

FIG. 3

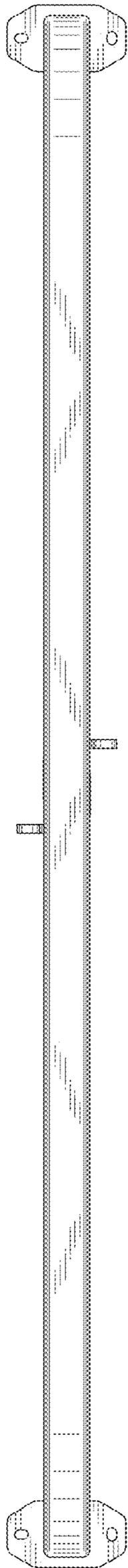

FIG. 4

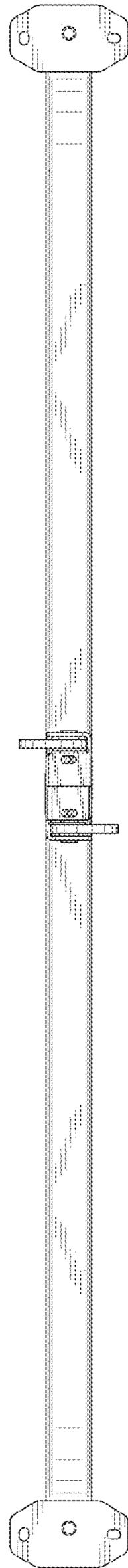

FIG. 5

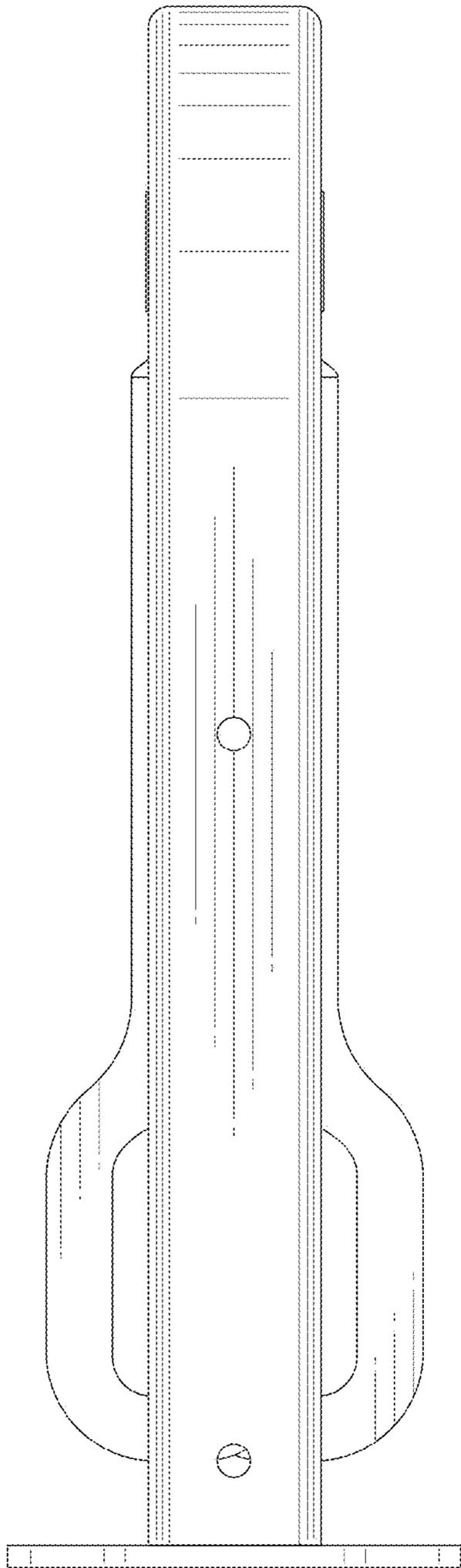

FIG. 6

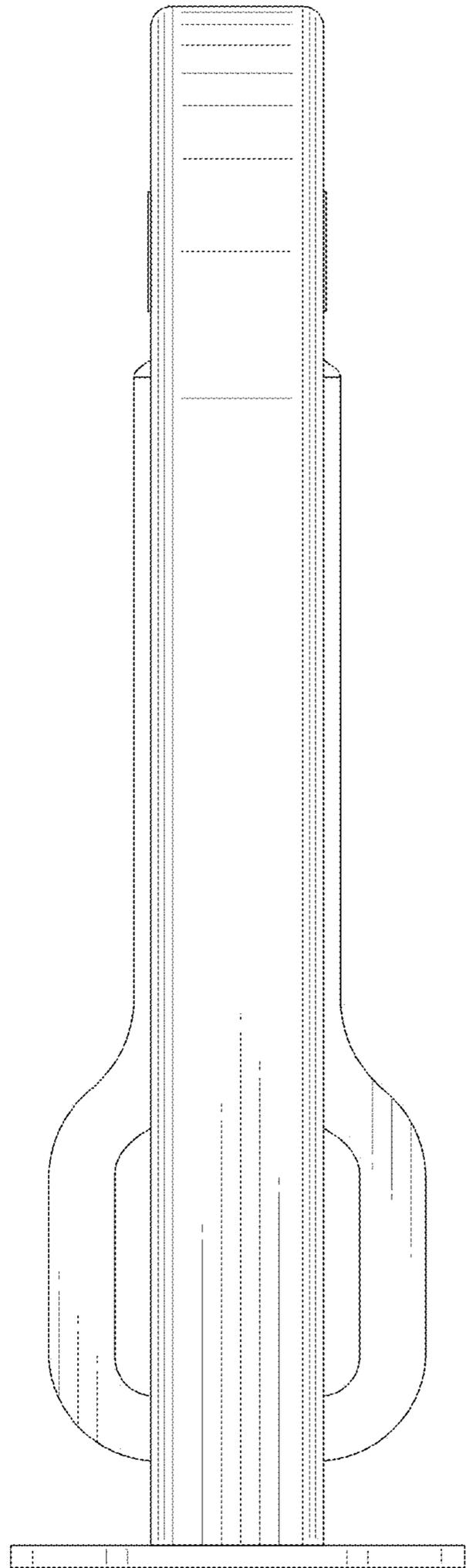

FIG. 7