



US00D903499S

(12) **United States Design Patent** (10) **Patent No.:** **US D903,499 S**  
**Nolan, Jr.** (45) **Date of Patent:** **\*\* Dec. 1, 2020**

(54) **PERFUME BOTTLE**  
(71) Applicant: **All Star Motivation.com**, Las Vegas, NV (US)  
(72) Inventor: **William P. Nolan, Jr.**, Las Vegas, NV (US)  
(73) Assignee: **ALL STAR MOTIVATION.COM**, Las Vegas, NV (US)

D345,500 S \* 3/1994 Wacker ..... D9/686  
D407,320 S \* 3/1999 Costen ..... D9/544  
D422,899 S \* 4/2000 Kudo ..... D9/521  
D450,576 S \* 11/2001 Taut ..... D9/668  
D561,852 S \* 2/2008 Frey ..... D21/710  
D581,288 S \* 11/2008 Villalobos ..... D9/668  
D590,269 S \* 4/2009 Pavone ..... D9/545  
D597,848 S \* 8/2009 Petzold ..... D9/545  
D657,680 S \* 4/2012 Cora ..... D9/521  
D804,316 S \* 12/2017 Hainaut ..... D9/544  
D838,325 S \* 1/2019 Miller ..... D21/710

(\*\*) Term: **15 Years**

\* cited by examiner

(21) Appl. No.: **29/691,122**

Primary Examiner — Sandra L Morris

(22) Filed: **May 14, 2019**

(74) Attorney, Agent, or Firm — Dickinson Wright PLLC

(51) **LOC (12) Cl.** ..... **09-01**  
(52) **U.S. Cl.**  
USPC ..... **D9/668**; D9/521; D9/567; D9/575

(57) **CLAIM**

The ornamental design for a perfume bottle, as shown and described.

(58) **Field of Classification Search**  
USPC ..... D9/600, 668, 500–505, 516, 519–521, D9/544–546, 567, 572–575, 682, 686; 206/457, 494, 459.5, 527, 540; 229/116.1; 215/381–384, 400; D7/514–521, 539, 544, 571, 594, 599, D7/604, 606, 613, 619.2, 623, 625, D7/628–630, 391–392.1, 396.4; D3/270–271.8; D21/710  
CPC ..... B65D 67/00; B65D 81/36; B65D 81/60; B65D 81/368; B65D 37/00; B65D 5/42; B65D 5/4208; B65D 77/00; A63H 33/10; A63H 33/16  
See application file for complete search history.

**DESCRIPTION**

FIG. 1 is a perspective view of a perfume bottle;  
FIG. 2 is a front view of the perfume bottle wherein the back view is a mirror image of the front view;  
FIG. 3 is a right side view of the perfume bottle wherein the left side view is a mirror image of the right side view;  
FIG. 4 is a top view of the perfume bottle;  
FIG. 5 is a bottom view of the perfume bottle;  
FIG. 6 is a perspective view of the perfume bottle with a perfume cap removed;  
FIG. 7 is a front view of the perfume bottle with the perfume cap removed wherein the back view is a mirror image of the front view; and,  
FIG. 8 is a right side view of the perfume bottle with the perfume cap removed wherein the left side view is a mirror image of the right side view.  
The broken lines in FIGS. 1 through 8 represent environment only and form no part of the claimed design.

(56) **References Cited**

U.S. PATENT DOCUMENTS

D214,019 S \* 5/1969 Newman ..... D9/521  
D289,746 S \* 5/1987 Reisgies ..... D9/521  
D289,862 S \* 5/1987 Reisgies ..... D9/521

**1 Claim, 8 Drawing Sheets**

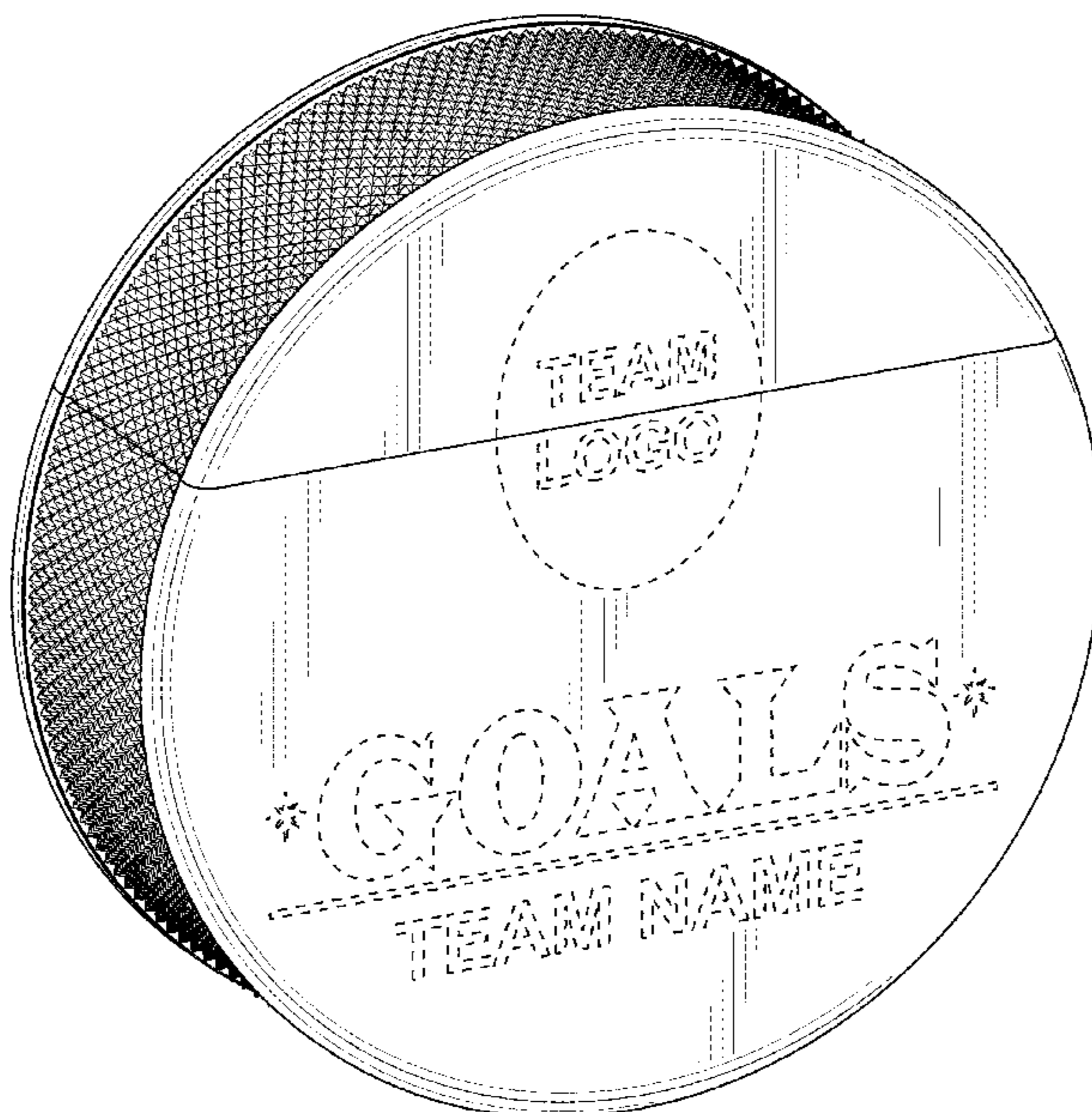

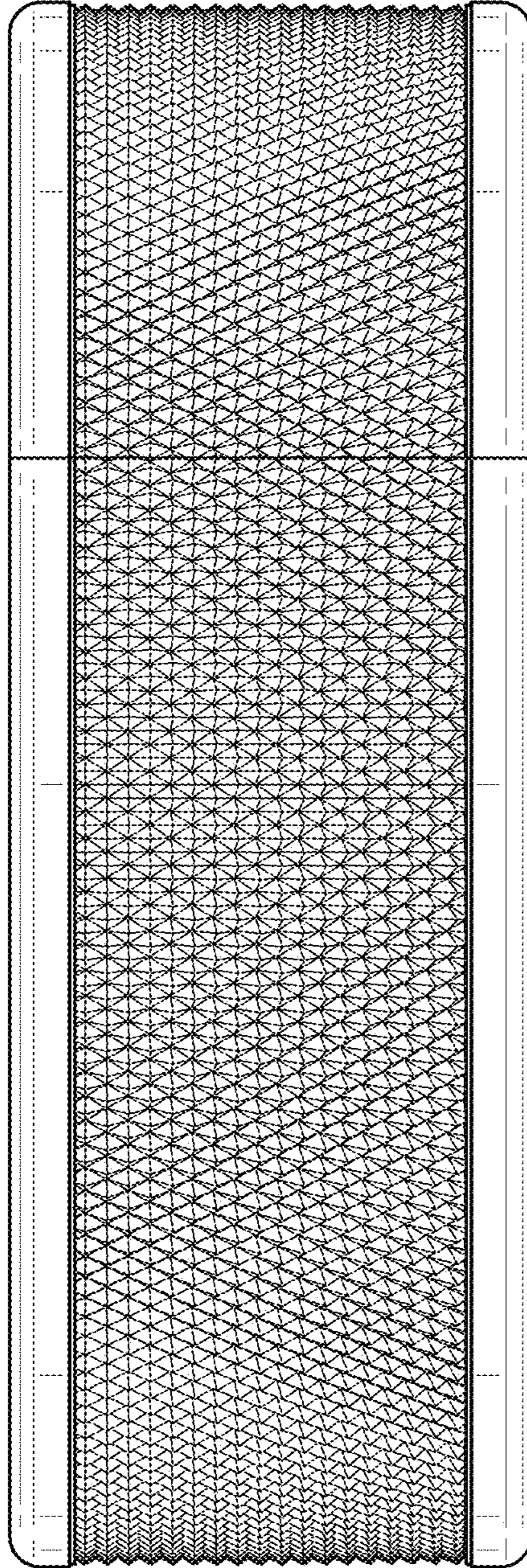

**FIG. 1**



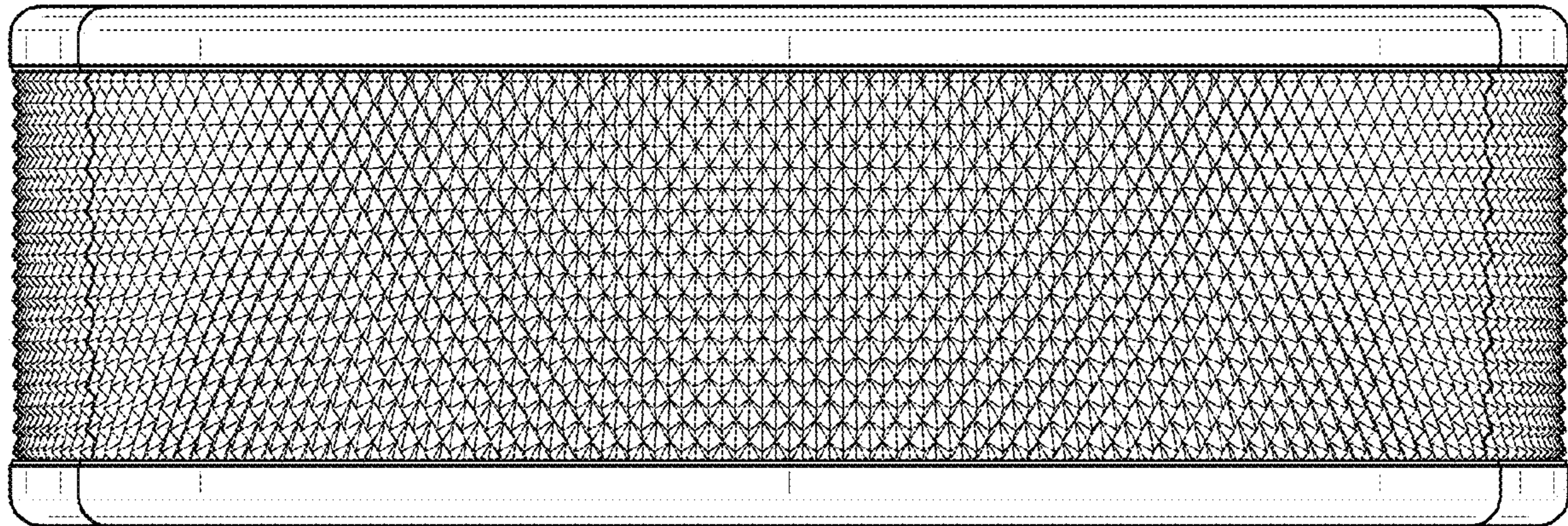

**FIG. 2**

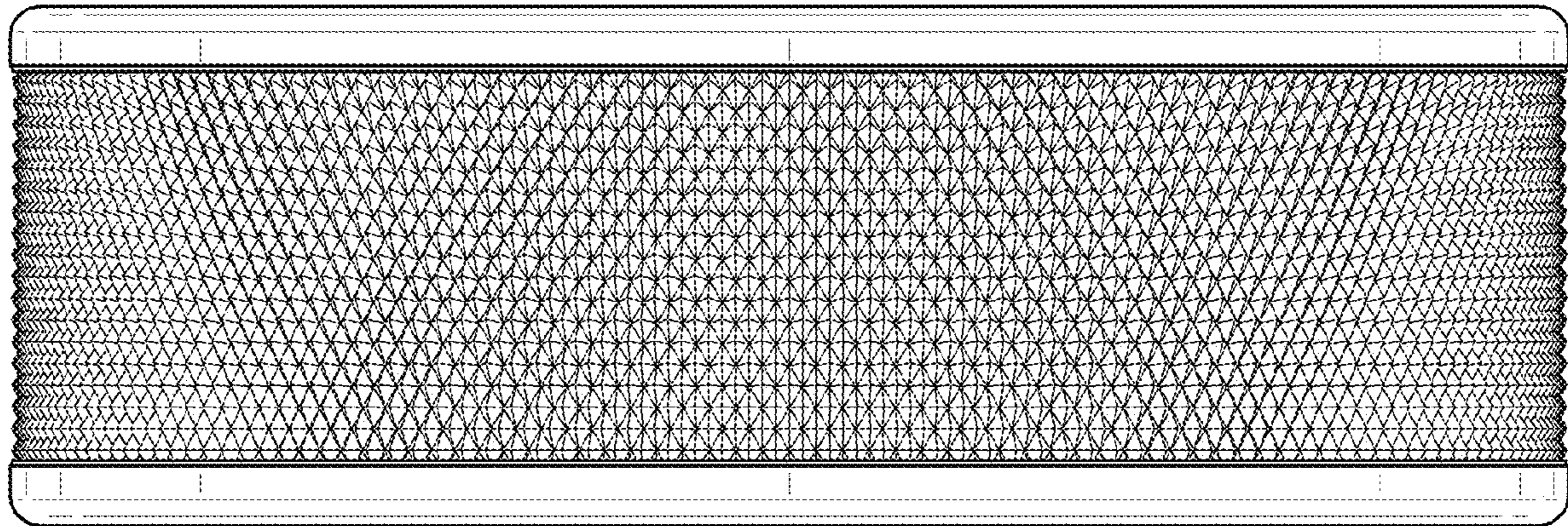

**FIG. 3**



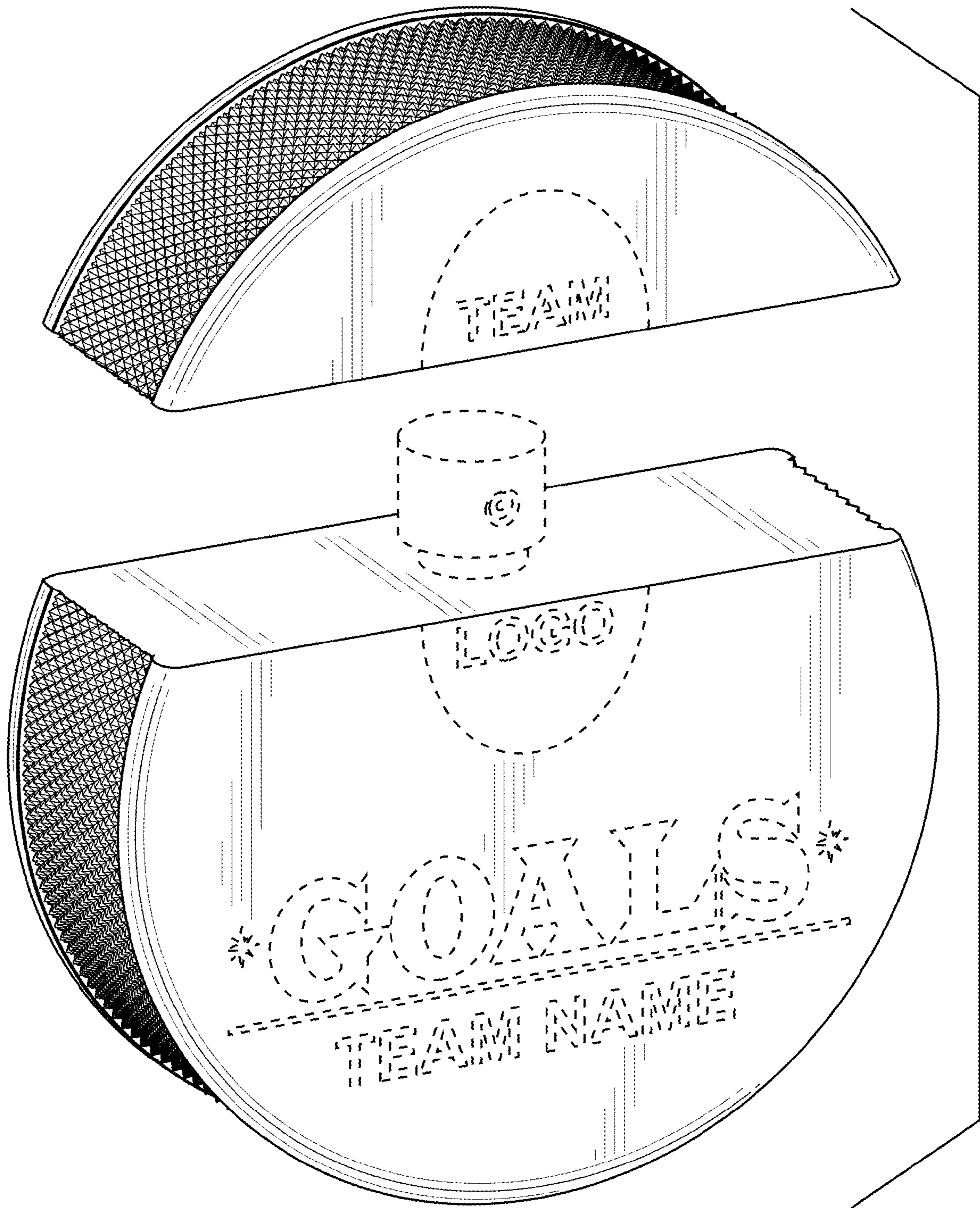

**FIG. 4**

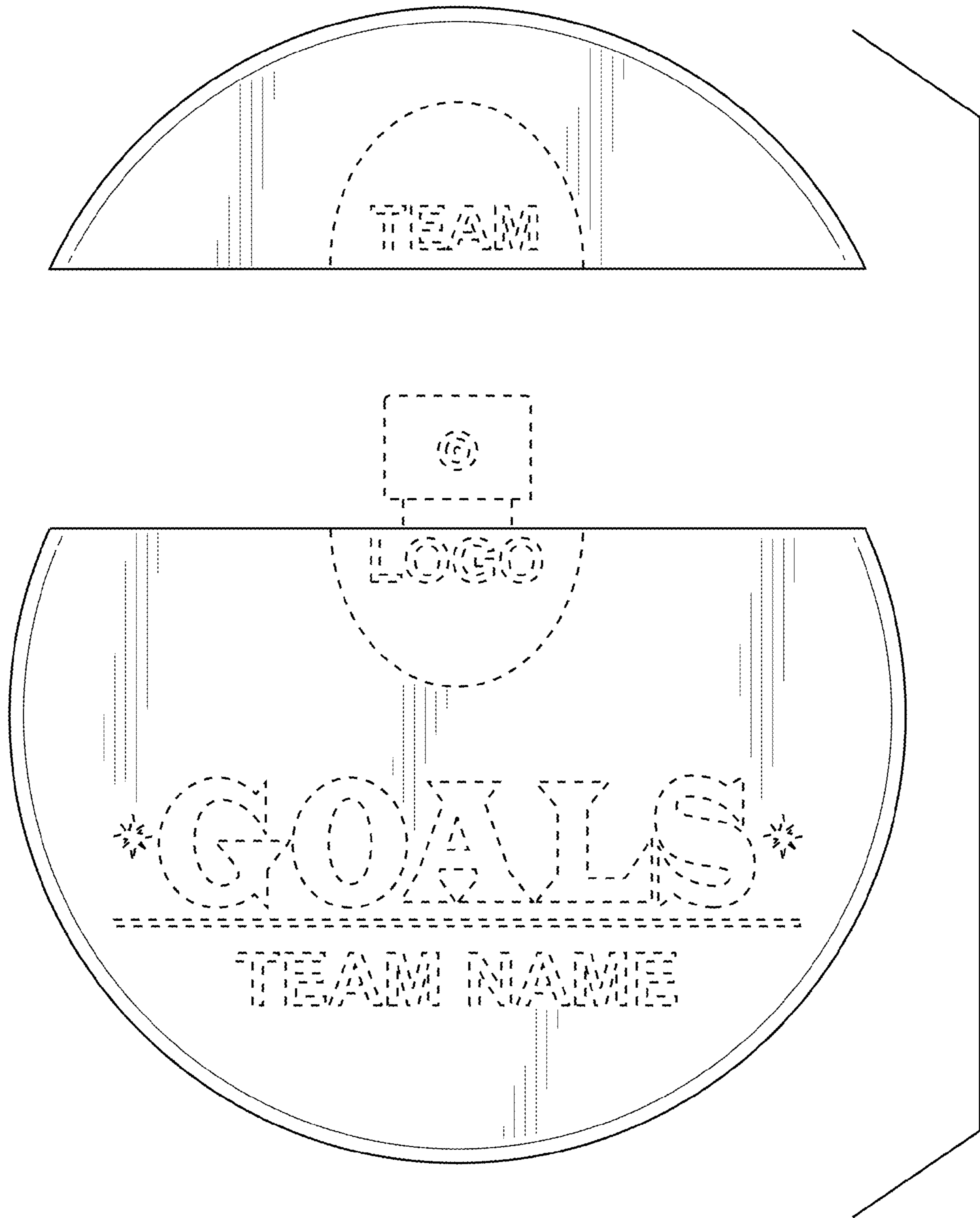

**FIG. 5**



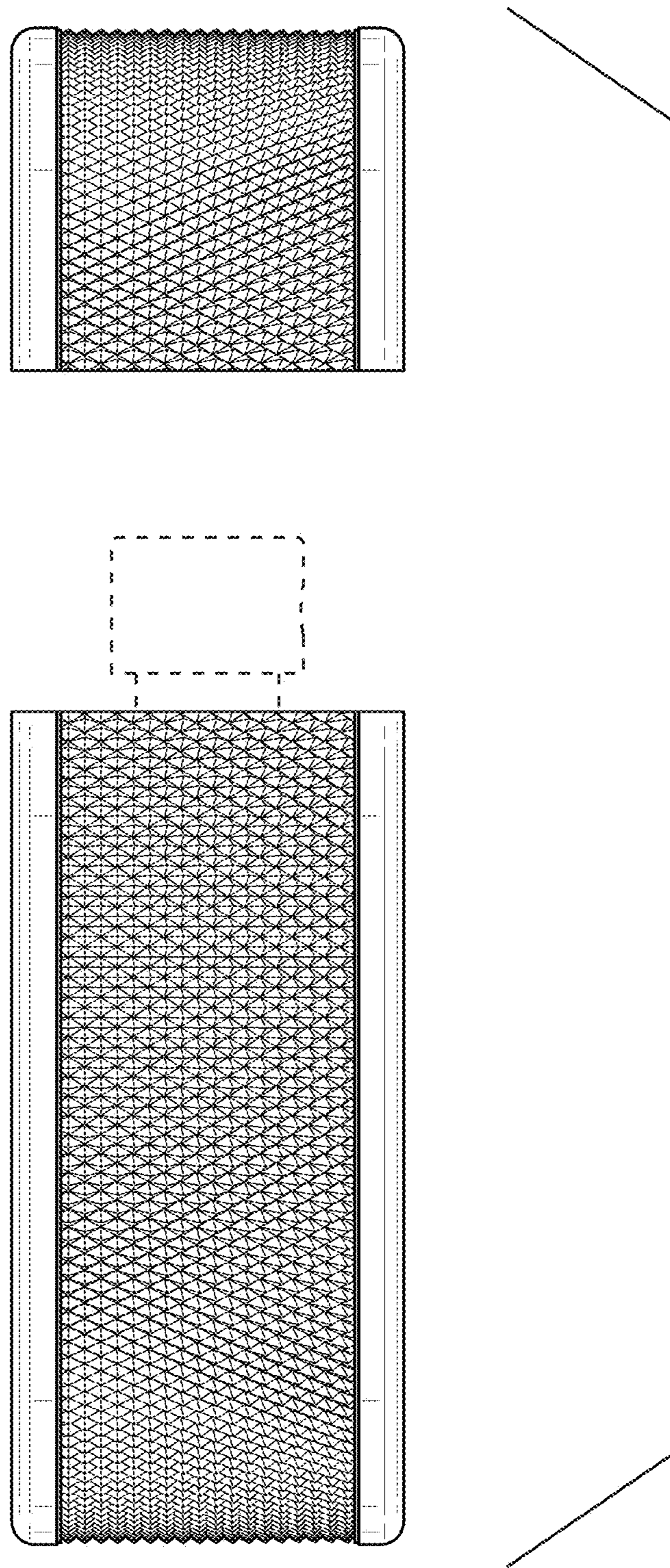

**FIG. 6**



**FIG. 7**





**FIG. 8**