



US00D903479S

(12) **United States Design Patent** (10) **Patent No.:** **US D903,479 S**  
**Schick** (45) **Date of Patent:** **\*\* Dec. 1, 2020**

(54) **T-BOLT ANCHOR**  
(71) Applicant: **HOPS, Inc.**, Kutztown, PA (US)  
(72) Inventor: **Joseph Schick**, Kutztown, PA (US)  
(73) Assignee: **HOPS, Inc.**, Kutztown, PA (US)  
(\*\*) Term: **15 Years**  
(21) Appl. No.: **29/693,806**  
(22) Filed: **Jun. 5, 2019**  
(51) **LOC (12) Cl.** ..... **08-08**  
(52) **U.S. Cl.**  
USPC ..... **D8/397**; D8/382  
(58) **Field of Classification Search**  
USPC ..... D8/349, 354, 366, 381, 382, 385, 386,  
D8/387, 396, 397, 398, 399  
CPC ..... F16B 39/22; F16B 39/225; F16B 39/24;  
F16B 39/26; F16B 39/28; F16B 39/282;  
A01K 1/06  
See application file for complete search history.

D398,048 S \* 9/1998 Casady ..... D23/386  
D398,835 S \* 9/1998 Coll ..... D8/354  
D399,125 S \* 10/1998 Blanchard ..... D8/354  
(Continued)

**OTHER PUBLICATIONS**

<http://sdimfg.com/products.hardware/t-bolts>, 1 page, Apr. 6, 2017, retrieved from Internet Archive Wayback Machine SDI T-Bolts. <https://web.archive.org/web/20200222162846/http://sdimfg.com/products/hardware/t-bolts/> on Sep. 21, 2020.

*Primary Examiner* — Sandra Snapp  
*Assistant Examiner* — Ieisha N Price  
(74) *Attorney, Agent, or Firm* — Clinton H. Wilkinson

(57) **CLAIM**

The ornamental design for a T-bolt anchor, as shown and described.

**DESCRIPTION**

FIG. 1 is a top perspective view of a T-bolt anchor showing my new design.  
FIG. 2 is a bottom perspective view thereof.  
FIG. 3 is a top perspective view thereof with the parts of the design separated.  
FIG. 4 is a top perspective view thereof.  
FIG. 5 is a front view thereof, the back view being identical.  
FIG. 6 is a right view thereof, the left view being identical.  
FIG. 7 is a bottom view thereof; and,  
FIG. 8 is another top perspective view thereof.  
The evenly spaced broken lines in the drawings illustrate portions of a T-bolt that is for the purpose of illustrating environmental matter and forms no part of the claimed design. The dot-dash-dot broken lines in the drawings define the bounds of the claim and form no part thereof.

(56) **References Cited**

**U.S. PATENT DOCUMENTS**

D29,156 S \* 8/1898 Caldwell ..... D12/223  
D59,346 S 10/1921 Gill  
1,793,745 A \* 2/1931 Norwood ..... F16B 39/24  
411/101  
2,820,843 A \* 1/1958 Dreher ..... H01R 4/2495  
174/87  
3,141,221 A \* 7/1964 Faulls, Jr. .... B65D 33/1666  
24/30.5 R  
4,075,924 A \* 2/1978 McSherry ..... F16B 13/0808  
411/112  
D279,959 S \* 8/1985 Nimmo ..... D8/382  
4,650,386 A \* 3/1987 McSherry ..... F16B 13/0808  
411/340  
D297,702 S \* 9/1988 Persson ..... D8/14  
4,813,809 A \* 3/1989 Stratman ..... F16B 2/10  
248/500

**1 Claim, 3 Drawing Sheets**

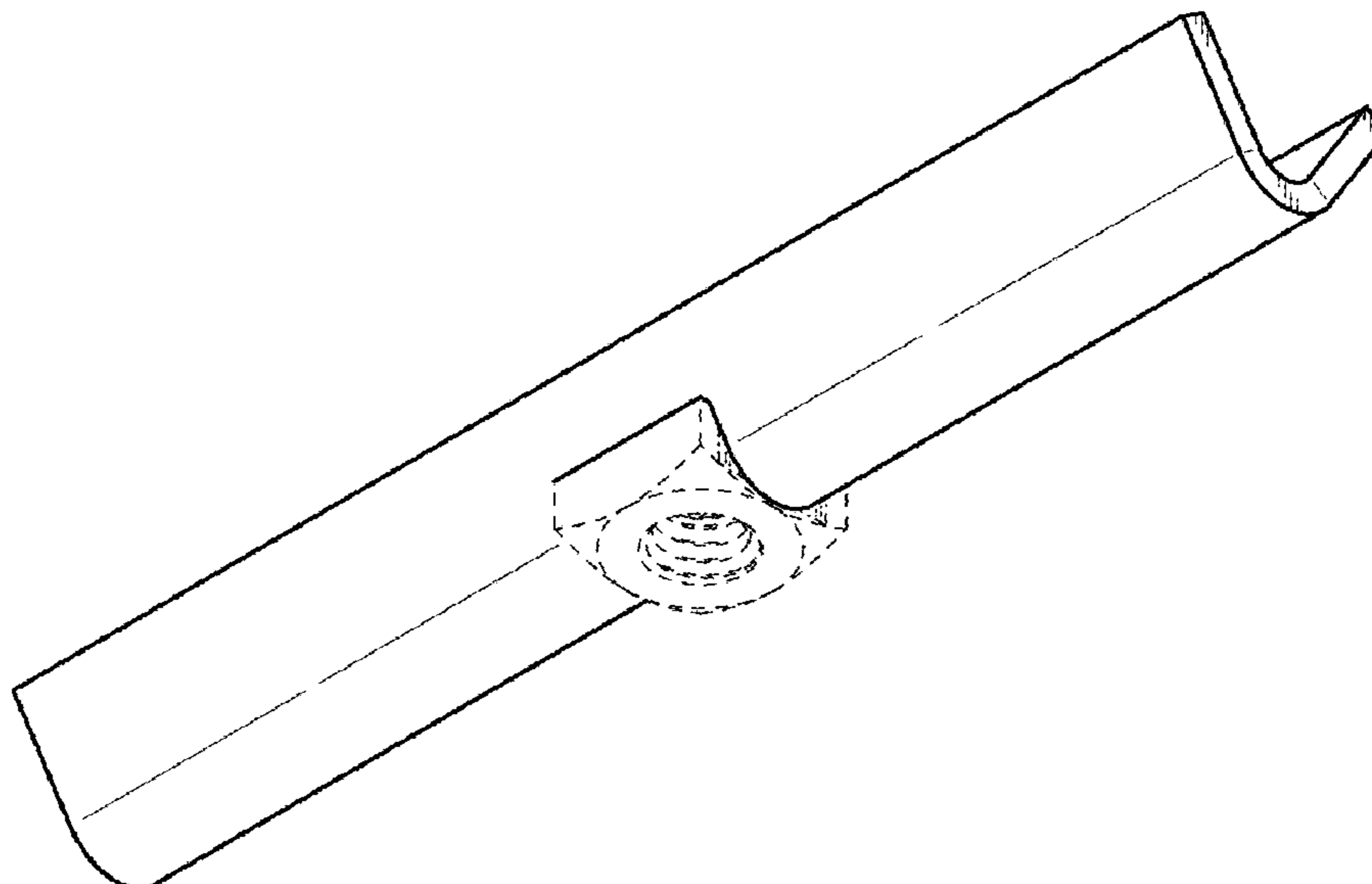

(56)

References Cited

U.S. PATENT DOCUMENTS

6,161,999 A \* 12/2000 Kaye ..... F16B 13/0808  
411/344  
6,413,005 B1 7/2002 Massie  
D461,657 S \* 8/2002 Magnusson ..... D8/381  
D476,134 S \* 6/2003 Miller ..... D2/609  
D481,001 S \* 10/2003 Gaudron ..... D12/215  
D494,997 S \* 8/2004 Weiler ..... D18/40  
D513,970 S \* 1/2006 Sterling ..... D8/381  
D532,682 S \* 11/2006 Maciag ..... D8/387  
D608,183 S \* 1/2010 Meyer ..... D8/354  
D631,736 S 2/2011 You  
D637,477 S \* 5/2011 Wall ..... D8/382  
D639,646 S 6/2011 Finley, Jr.  
D651,890 S \* 1/2012 Gaudron ..... D8/385  
D653,524 S \* 2/2012 Meyer ..... D8/354  
D698,634 S 2/2014 Oetlinger  
D712,472 S \* 9/2014 Yuval ..... D19/65  
D722,489 S 2/2015 Yamazaki  
D733,545 S \* 7/2015 Charette ..... D8/387  
D760,583 S \* 7/2016 Weilage ..... D8/396  
D766,688 S \* 9/2016 Cozzolino ..... D8/42

D801,782 S \* 11/2017 Wall ..... D8/356  
D805,375 S \* 12/2017 Nehls ..... D8/381  
D821,188 S \* 6/2018 Smullen ..... D8/396  
D824,756 S \* 8/2018 Fischer ..... D8/395  
D850,504 S \* 6/2019 Welter ..... D15/149  
D871,900 S \* 1/2020 McDuff ..... D8/385  
D876,211 S \* 2/2020 Wassdahl ..... D8/382  
D882,831 S \* 4/2020 Carter ..... D25/133  
D883,078 S \* 5/2020 Ma ..... D8/394  
2004/0170486 A1 \* 9/2004 DeMeo ..... F16B 13/0808  
411/340  
2011/0225793 A1 \* 9/2011 Daniels, III ..... A63B 29/024  
29/428  
2011/0268528 A1 \* 11/2011 Gaudron ..... F16B 13/0808  
411/44  
2014/0017031 A1 \* 1/2014 Prichard ..... F16B 13/0808  
411/204  
2014/0250825 A1 9/2014 Richardson  
2016/0264198 A1 \* 9/2016 Lorenzo ..... F16B 43/00  
2017/0307000 A1 \* 10/2017 Daly ..... F16B 13/0808  
2018/0347615 A1 \* 12/2018 Martin ..... F16B 2/245  
2019/0136539 A1 \* 5/2019 Davis ..... E06C 1/381

\* cited by examiner

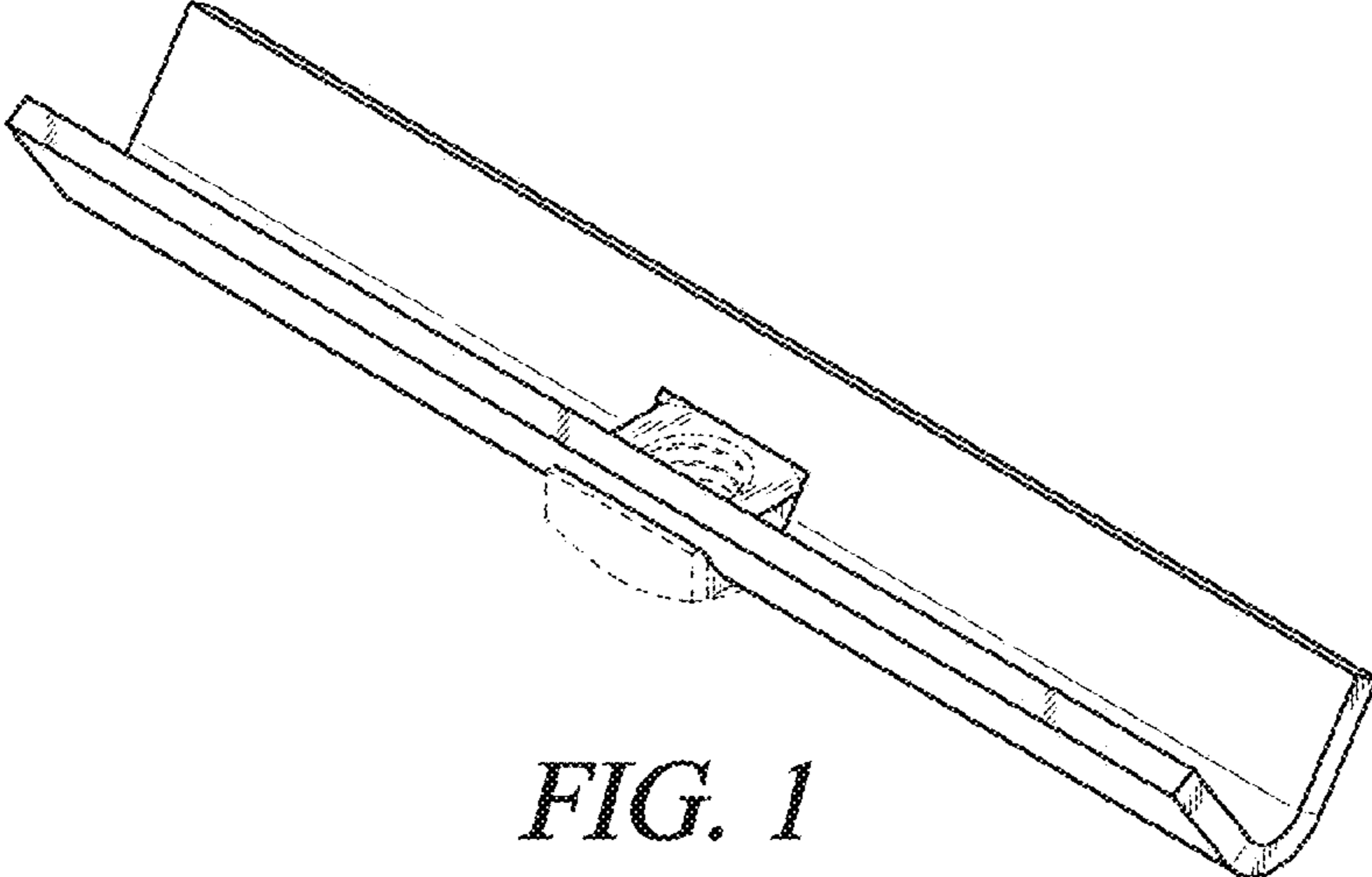

*FIG. 1*

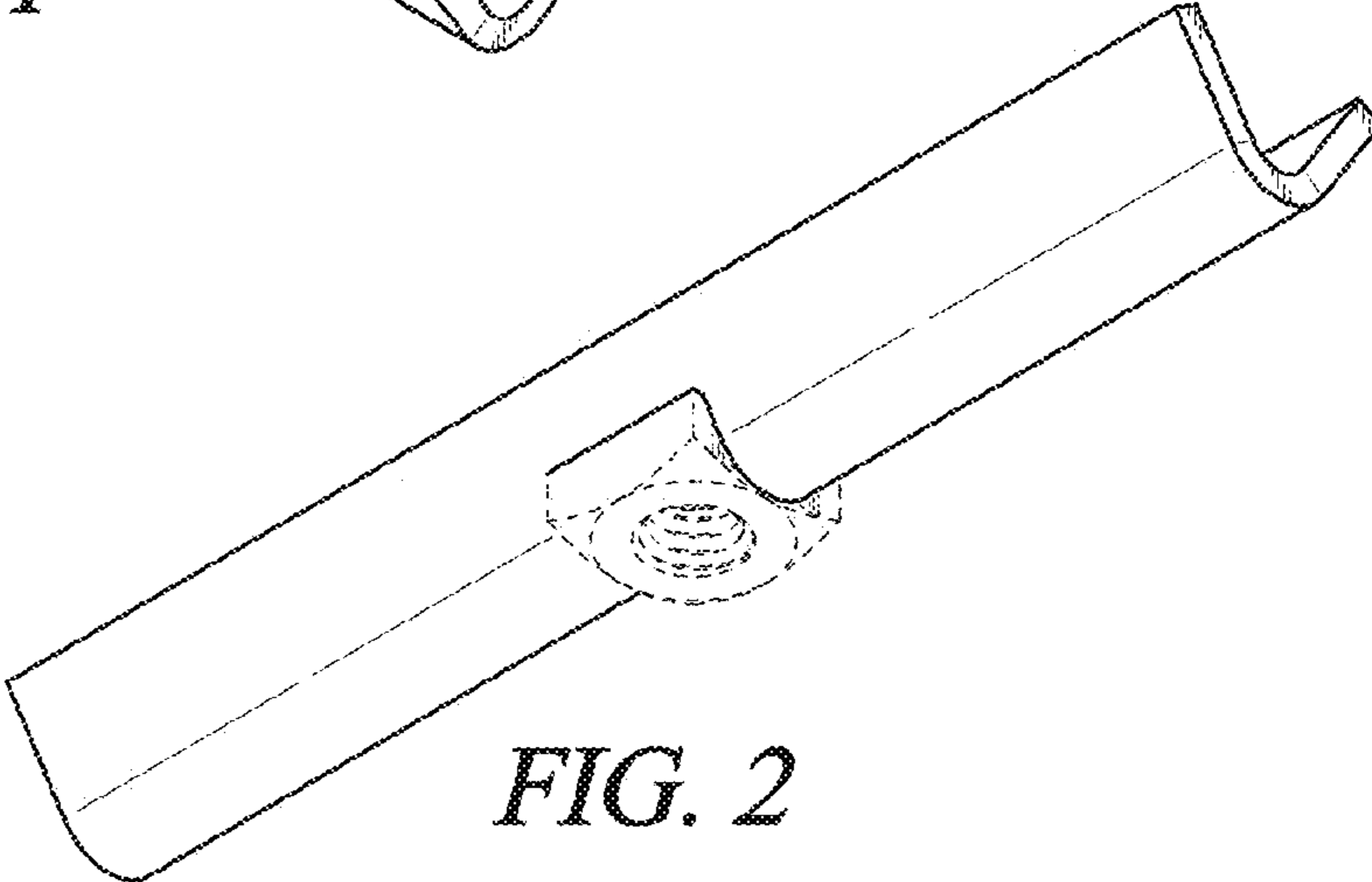

*FIG. 2*

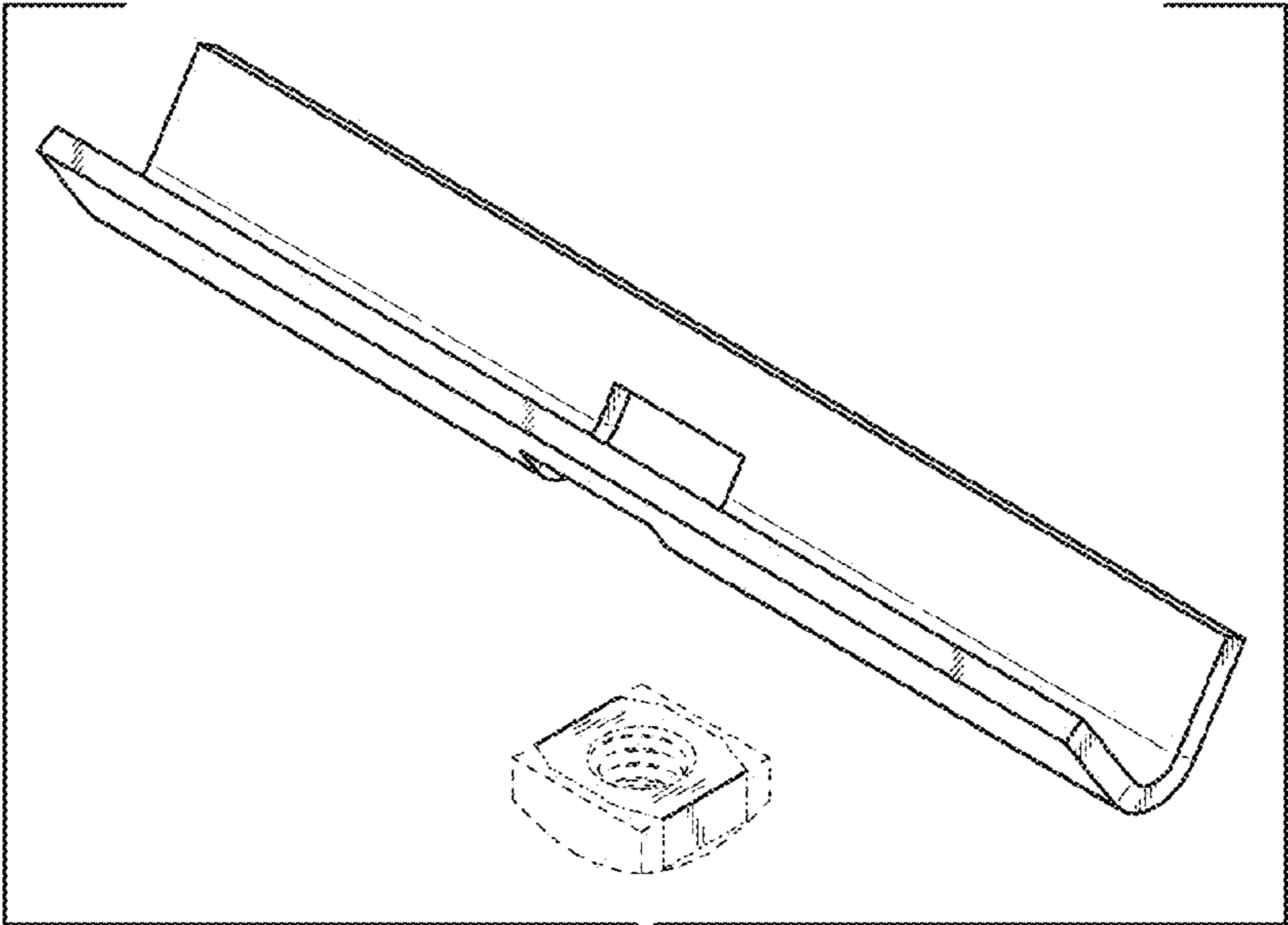

*FIG. 3*

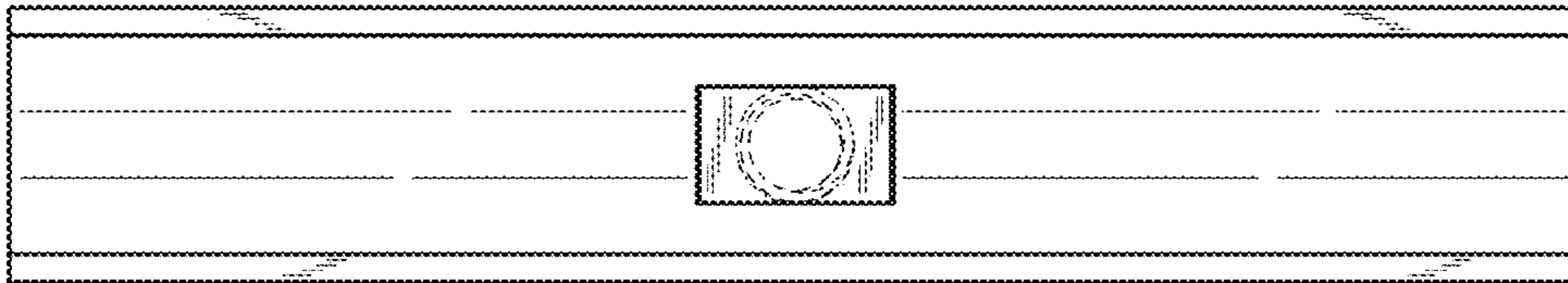

*FIG. 4*



*FIG. 5*



*FIG. 6*

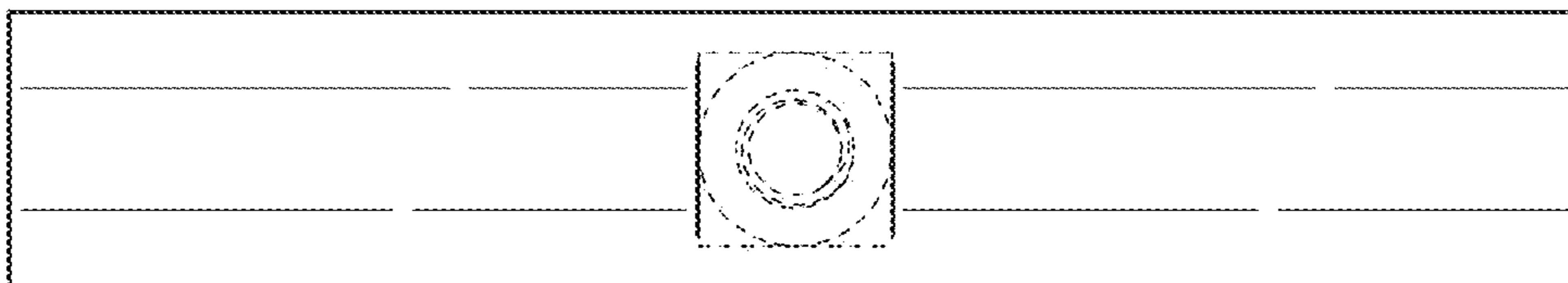

*FIG. 7*

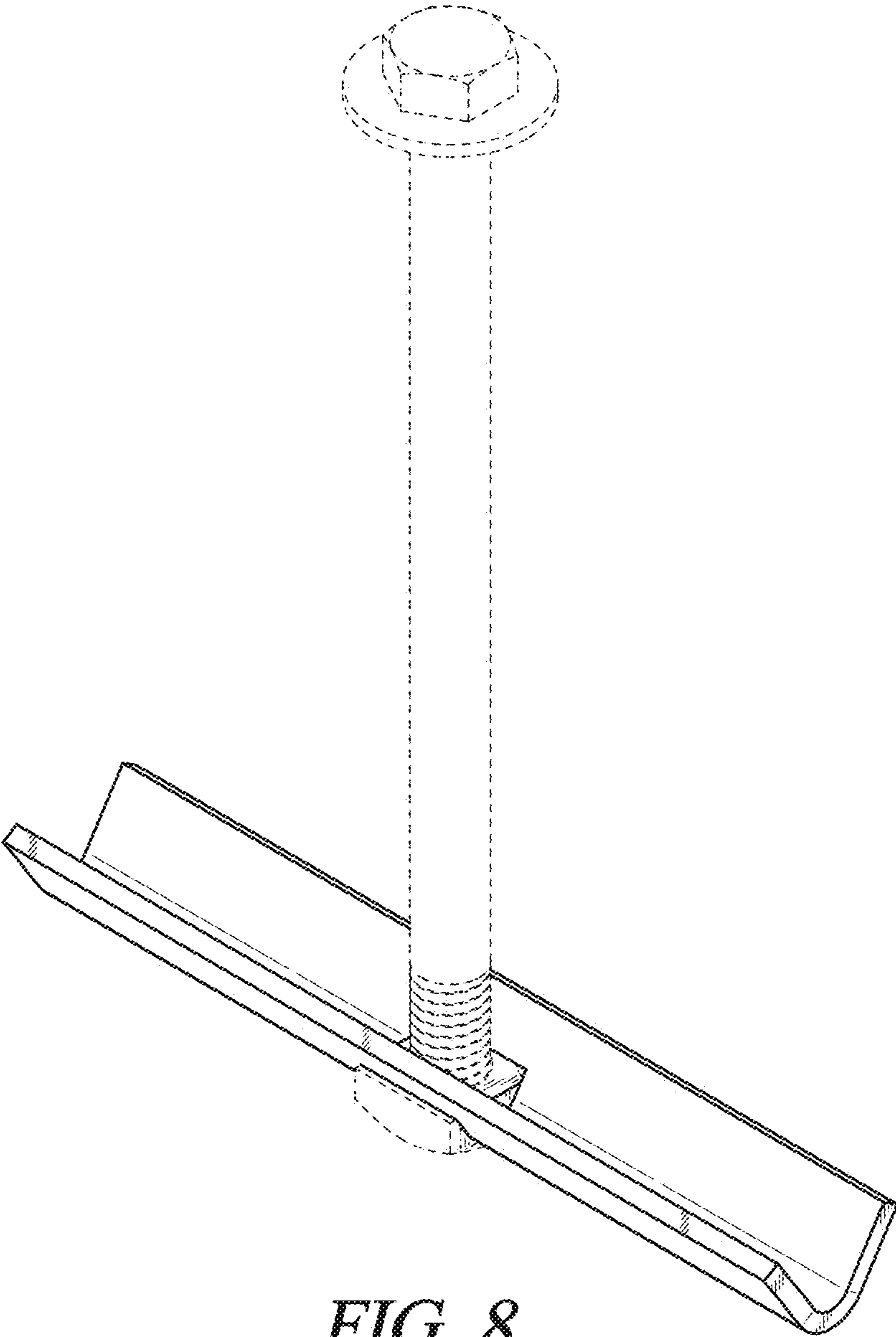

*FIG. 8*