



US00D903477S

(12) **United States Design Patent** (10) **Patent No.:** **US D903,477 S**
Goratela et al. (45) **Date of Patent:** **** Dec. 1, 2020**

(54) **METAL CLAMP**

(71) Applicant: **ASM IP Holding B.V.**, Almere (NL)

(72) Inventors: **Ankit Atul Goratela**, Phoenix, AZ (US); **Christopher Daniel Wuester**, Phoenix, AZ (US)

(73) Assignee: **ASM IP Holdings B.V.**, Almere (NL)

(**) Term: **15 Years**

(21) Appl. No.: **29/634,768**

(22) Filed: **Jan. 24, 2018**

(51) **LOC (12) Cl.** **08-08**

(52) **U.S. Cl.**
USPC **D8/394**

(58) **Field of Classification Search**
USPC D8/394-396, 499, 71-74; D24/180
CPC . H01R 9/05; A01K 87/06; A01M 1/02; B63B 21/08; B65D 63/00; A43C 1/00
See application file for complete search history.

(56) **References Cited**

U.S. PATENT DOCUMENTS

D30,036 S	1/1899	Rhind
D31,889 S	11/1899	Gill
D56,051 S	8/1920	Cohn
2,059,480 A	11/1936	Obermaier
2,161,626 A	6/1939	Loughner et al.
2,266,416 A	12/1941	Duclos
2,280,778 A	4/1942	Anderson
D142,841 S	11/1945	D'Algodt
2,410,420 A	11/1946	Bennett
2,563,931 A	8/1951	Harrison
2,660,061 A	11/1953	Lewis
2,745,640 A	5/1956	Cushman
2,990,045 A	9/1959	Root
3,038,951 A	6/1962	Mead
3,089,507 A	5/1963	Drake et al.
3,094,396 A	6/1963	Flugge et al.

3,232,437 A	2/1966	Hultgren
3,263,502 A	8/1966	Springfield
3,410,349 A	11/1968	Troutman
3,588,192 A	6/1971	Drutchas et al.
3,647,387 A	3/1972	Benson
3,647,716 A	3/1972	Koches

(Continued)

FOREIGN PATENT DOCUMENTS

CN	2588350	11/2003
CN	1563483	1/2005

(Continued)

OTHER PUBLICATIONS

ASM Products, ASM International website 2019. <http://www.asm.com/solutions/products>, site visited Aug. 15, 2019.*
(Continued)

Primary Examiner — John R Yeh
(74) *Attorney, Agent, or Firm* — Snell & Wilmer, L.L.P.

(57) **CLAIM**

The ornamental design of a metal clamp, as shown and described.

DESCRIPTION

FIG. 1 is a top perspective view of the metal clamp in accordance with a first embodiment of the design; FIG. 2 is a bottom perspective view thereof; FIG. 3 is a front view thereof; FIG. 4 is a back view thereof; FIG. 5 is a right side view thereof; FIG. 6 is a left side view thereof; FIG. 7 is a top view thereof; and, FIG. 8 is a bottom view thereof. The broken lines in the figures represent portions of the metal clamp that forms no part of the claimed design.

1 Claim, 8 Drawing Sheets

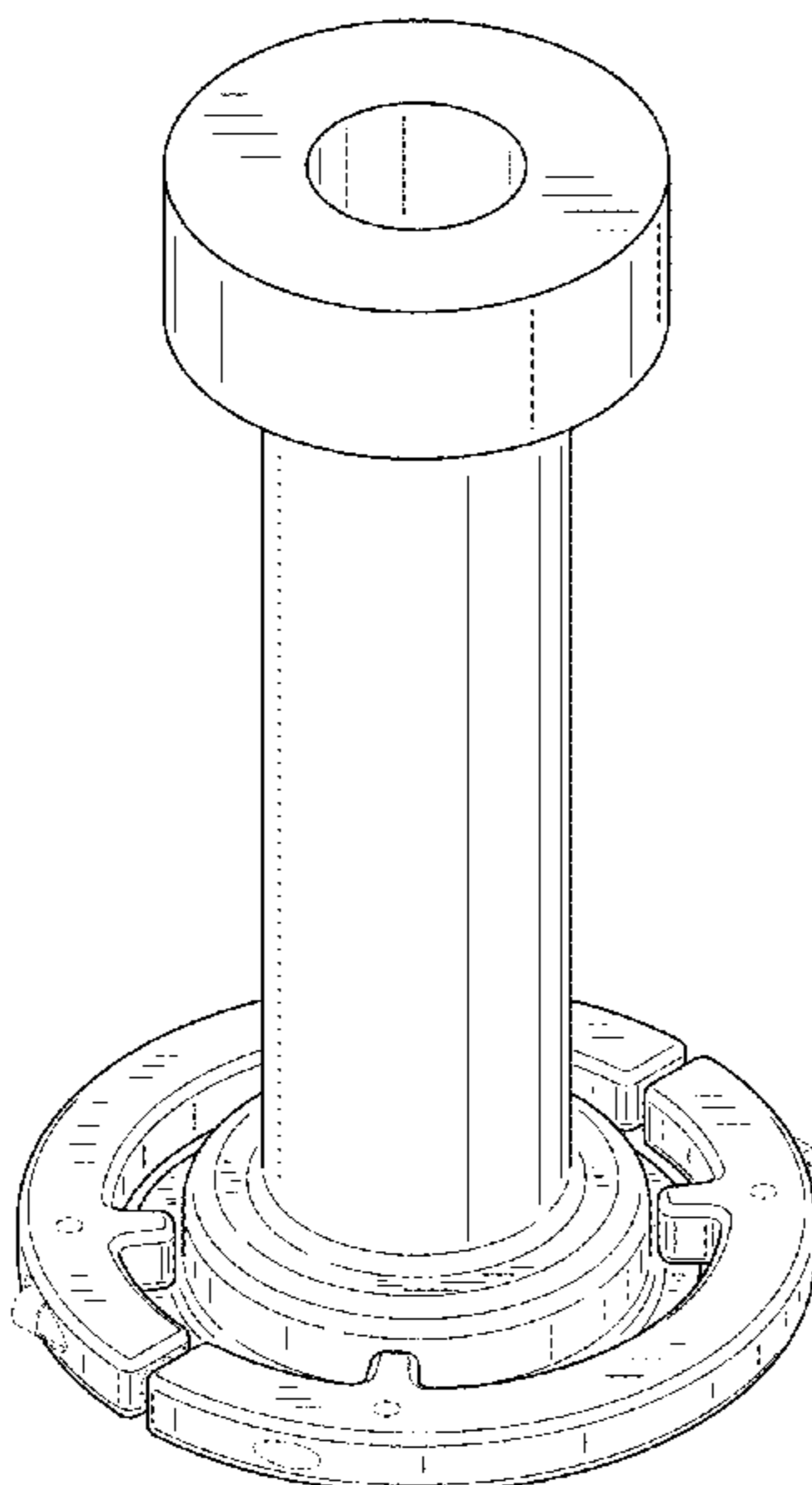

(56)

References Cited

U.S. PATENT DOCUMENTS

3,713,899 A	1/1973	Sebestyen	4,827,430 A	5/1989	Aid et al.
3,718,429 A	2/1973	Williamson	4,828,224 A	5/1989	Crabb et al.
3,833,492 A	9/1974	Bollyky	4,830,515 A	5/1989	Cortes
3,854,443 A	12/1974	Baerg	4,837,113 A	6/1989	Luttmer et al.
3,862,397 A	1/1975	Anderson et al.	4,837,185 A	6/1989	Yau et al.
3,867,205 A	2/1975	Schley	4,854,263 A	8/1989	Chang et al.
3,885,504 A	5/1975	Baermann	4,854,266 A	8/1989	Simson et al.
3,887,790 A	6/1975	Ferguson	4,857,137 A	8/1989	Tashiro et al.
3,904,371 A	9/1975	Neti	4,857,382 A	8/1989	Sheng et al.
3,913,058 A	10/1975	Nishio et al.	4,882,199 A	11/1989	Sadoway et al.
3,913,617 A	10/1975	van Laar	4,916,091 A	4/1990	Freeman et al.
3,947,685 A	3/1976	Meinel	4,934,831 A	6/1990	Volbrecht
3,960,559 A	6/1976	Suzuki	D309,702 S *	8/1990	Hall D8/72
3,997,638 A	12/1976	Manning et al.	4,949,848 A	8/1990	Kos
4,054,071 A	10/1977	Patejak	D311,126 S	10/1990	Crowley
4,058,430 A	11/1977	Suntola et al.	4,976,996 A	12/1990	Monkowski et al.
4,093,491 A	6/1978	Whelpton et al.	4,978,567 A	12/1990	Miller
D249,341 S	9/1978	Mertz	4,984,904 A	1/1991	Nakano et al.
4,126,027 A	11/1978	Smith et al.	4,985,114 A	1/1991	Okudaira
4,134,425 A	1/1979	Gussefeld et al.	4,986,215 A	1/1991	Yamada
4,145,699 A	3/1979	Hu et al.	4,987,102 A	1/1991	Nguyen et al.
4,164,959 A	8/1979	Wurzburger	4,987,856 A	1/1991	Hey
4,176,630 A	12/1979	Elmer	4,989,992 A	2/1991	Piai
4,181,330 A	1/1980	Kojima	4,991,614 A	2/1991	Hammel
4,194,536 A	3/1980	Stine et al.	5,002,632 A	3/1991	Loewenstein et al.
4,217,463 A	8/1980	Swearingen	5,013,691 A	5/1991	Lory et al.
4,234,449 A	11/1980	Wolson et al.	5,027,746 A	7/1991	Frijlink
4,322,592 A	3/1982	Martin	5,028,366 A	7/1991	Harakal et al.
4,333,735 A	6/1982	Hardy	D320,148 S *	9/1991	Andrews D8/70
4,355,912 A	10/1982	Haak	5,053,247 A	10/1991	Moore
4,389,973 A	6/1983	Suntola et al.	5,057,436 A	10/1991	Ball
D269,850 S *	7/1983	Preisler D8/303	5,060,322 A	10/1991	Delepine
4,393,013 A	7/1983	McMenamin	5,061,083 A	10/1991	Grimm et al.
4,401,507 A	8/1983	Engle	5,062,386 A	11/1991	Christensen
4,414,492 A	11/1983	Hanlet	5,065,698 A	11/1991	Koike
4,436,674 A	3/1984	McMenamin	5,069,591 A	12/1991	Kinoshita
4,444,990 A	4/1984	Villar	5,071,258 A	12/1991	Usher et al.
D274,122 S *	6/1984	Stahel D8/303	5,074,017 A	12/1991	Toya et al.
4,454,370 A	6/1984	Voznick	5,082,517 A	1/1992	Moslehi
4,455,193 A	6/1984	Jeuch et al.	5,084,126 A	1/1992	McKee
4,466,766 A	8/1984	Geren et al.	5,098,638 A	3/1992	Sawada
4,479,831 A	10/1984	Sadow	5,098,865 A	3/1992	MacHado
4,499,354 A	2/1985	Hill et al.	5,104,514 A	4/1992	Quartarone
4,512,113 A	4/1985	Budinger	5,108,192 A	4/1992	Mailliet et al.
4,527,005 A	7/1985	McKelvey et al.	5,110,407 A	5/1992	Ono et al.
4,537,001 A	8/1985	Uppstrom	5,116,018 A	5/1992	Friemoth et al.
4,548,688 A	10/1985	Mathews	D327,534 S	6/1992	Manville
4,570,328 A	2/1986	Price et al.	5,119,760 A	6/1992	McMillan et al.
4,575,636 A	3/1986	Caprari	5,130,003 A	7/1992	Conrad
4,578,560 A	3/1986	Tanaka et al.	5,137,286 A	8/1992	Whitford
4,579,080 A	4/1986	Martin et al.	5,151,296 A	9/1992	Tokunaga
4,579,378 A	4/1986	Snyders	5,154,301 A	10/1992	Kos
4,579,623 A	4/1986	Suzuki et al.	5,158,128 A	10/1992	Inoue et al.
4,590,326 A	5/1986	Woldy	D330,900 S *	11/1992	Wakegijig D15/138
4,611,966 A	9/1986	Johnson	5,167,716 A	12/1992	Boitnott et al.
4,620,998 A	11/1986	Lalvani	5,176,451 A	1/1993	Sasada
D288,556 S	3/1987	Wallgren	5,178,682 A	1/1993	Tsukamoto et al.
4,653,541 A	3/1987	Oehlschlaeger et al.	5,181,779 A	1/1993	Shia et al.
4,654,226 A	3/1987	Jackson et al.	5,183,511 A	2/1993	Yamazaki et al.
4,664,769 A	5/1987	Cuomo et al.	5,192,717 A	3/1993	Kawakami
4,681,134 A	7/1987	Paris	5,194,401 A	3/1993	Adams et al.
4,718,637 A	1/1988	Contin	5,199,603 A	4/1993	Prescott
4,721,533 A	1/1988	Phillippi et al.	5,213,650 A	5/1993	Wang et al.
4,722,298 A	2/1988	Rubin et al.	5,221,556 A	6/1993	Hawkins et al.
4,724,272 A	2/1988	Raniere et al.	5,225,366 A	7/1993	Yoder et al.
4,735,259 A	4/1988	Vincent	5,226,383 A	7/1993	Bhat
4,749,416 A	6/1988	Greenspan	5,228,114 A	7/1993	Suzuki
4,753,192 A	6/1988	Goldsmith et al.	5,242,539 A	9/1993	Kumihashi et al.
4,753,856 A	6/1988	Haluska et al.	5,243,195 A	9/1993	Nishi
4,756,794 A	7/1988	Yoder	5,243,202 A	9/1993	Mori et al.
4,771,015 A	9/1988	Kanai	5,246,218 A	9/1993	Yap et al.
4,780,169 A	10/1988	Stark et al.	5,246,500 A	9/1993	Samata et al.
4,789,294 A	12/1988	Sato et al.	5,259,881 A	11/1993	Edwards et al.
4,812,201 A	3/1989	Sakai et al.	5,266,526 A	11/1993	Aoyama
4,821,674 A	4/1989	deBoer et al.	5,271,967 A	12/1993	Kramer et al.
			5,273,609 A	12/1993	Moslehi
			5,278,494 A	1/1994	Obigane
			5,279,886 A	1/1994	Kawai et al.
			5,281,274 A	1/1994	Yoder

(56)

References Cited

U.S. PATENT DOCUMENTS

5,284,519 A	2/1994	Gadgil	5,601,641 A	2/1997	Stephens
5,288,684 A	2/1994	Yamazaki et al.	5,602,060 A	2/1997	Kobayashi et al.
5,294,778 A	3/1994	Carman et al.	5,604,410 A	2/1997	Vollkommer et al.
5,305,417 A	4/1994	Najm et al.	5,616,264 A	4/1997	Nishi et al.
5,306,666 A	4/1994	Izumi	5,616,947 A	4/1997	Tamura
5,306,946 A	4/1994	Yamamoto	5,621,982 A	4/1997	Yamashita
5,310,456 A	5/1994	Kadomura	5,632,919 A	5/1997	MacCracken et al.
5,313,061 A	5/1994	Drew et al.	D380,527 S	7/1997	Velez
5,314,570 A	5/1994	Ikegaya et al.	5,656,093 A	8/1997	Burkhart et al.
5,315,092 A	5/1994	Takahashi et al.	5,663,899 A	9/1997	Zvonar et al.
5,320,218 A	6/1994	Yamashita et al.	5,665,608 A	9/1997	Chapple-Sokol et al.
5,326,427 A	7/1994	Jerbic	5,667,592 A	9/1997	Boitnott et al.
5,336,327 A	8/1994	Lee	5,679,215 A	10/1997	Barnes et al.
5,338,362 A	8/1994	Imahashi	5,681,779 A	10/1997	Pasch et al.
5,348,774 A	9/1994	Golecki et al.	D386,076 S	11/1997	Moore
5,350,480 A	9/1994	Gray	5,683,517 A	11/1997	Shan
5,354,580 A	10/1994	Goela et al.	5,685,912 A	11/1997	Nishizaka
5,356,478 A	10/1994	Chen et al.	5,695,567 A	12/1997	Kordina
5,356,672 A	10/1994	Schmitt et al.	5,697,706 A	12/1997	Ciaravino et al.
5,360,269 A	11/1994	Ogawa et al.	5,700,729 A	12/1997	Lee et al.
5,364,667 A	11/1994	Rhieu	5,708,825 A	1/1998	Sotomayor
D353,452 S	12/1994	Groenhoff	5,709,745 A	1/1998	Larkin et al.
5,374,315 A	12/1994	Deboer et al.	5,711,811 A	1/1998	Suntola et al.
D354,898 S *	1/1995	Nagy D19/37	5,716,133 A	2/1998	Hosokawa et al.
5,380,367 A	1/1995	Bertone	5,718,574 A	2/1998	Shimazu
5,382,311 A	1/1995	Ishikawa et al.	D392,855 S	3/1998	Pillow
5,388,945 A	2/1995	Garric et al.	5,724,748 A	3/1998	Brooks
5,397,395 A	3/1995	Sano et al.	5,728,223 A	3/1998	Murakarni et al.
5,403,630 A	4/1995	Matsui et al.	5,728,425 A	3/1998	Ebe et al.
5,404,082 A	4/1995	Hernandez et al.	5,730,801 A	3/1998	Tepman et al.
5,407,449 A	4/1995	Zinger	5,730,802 A	3/1998	Ishizumi et al.
5,413,813 A	5/1995	Cruse et al.	5,732,744 A	3/1998	Barr et al.
5,414,221 A	5/1995	Gardner	5,736,314 A	4/1998	Hayes et al.
5,415,753 A	5/1995	Hurwitt et al.	5,753,835 A	5/1998	Gustin
5,418,382 A	5/1995	Blackwood et al.	5,761,328 A	6/1998	Solberg et al.
5,421,893 A	6/1995	Perlov	5,777,838 A	7/1998	Tamagawa et al.
5,422,139 A	6/1995	Fischer	5,779,203 A	7/1998	Edlinger
5,423,942 A	6/1995	Robbins et al.	5,781,693 A	7/1998	Balance et al.
5,426,137 A	6/1995	Allen	5,782,979 A	7/1998	Kaneno
5,430,011 A	7/1995	Tanaka et al.	5,791,782 A	8/1998	Wooten et al.
5,431,734 A	7/1995	Chapple-Sokol et al.	5,792,272 A	8/1998	Van Os et al.
5,444,217 A	8/1995	Moore	5,796,074 A	8/1998	Edelstein et al.
5,447,294 A	9/1995	Sakata et al.	5,801,104 A	9/1998	Schuegraf et al.
5,453,124 A	9/1995	Moslehi et al.	5,801,945 A	9/1998	Commer
D363,464 S	10/1995	Fukasawa	5,806,980 A	9/1998	Berrian
5,462,899 A	10/1995	Ikeda	5,813,851 A	9/1998	Nakao
5,463,176 A	10/1995	Eckert	5,819,092 A	10/1998	Ferguson et al.
5,480,818 A	1/1996	Matsumoto et al.	5,819,434 A	10/1998	Herchen et al.
5,482,559 A	1/1996	Imai et al.	5,827,420 A	10/1998	Shirazi et al.
5,484,484 A	1/1996	Yamaga et al.	5,827,435 A	10/1998	Seiji
5,494,494 A	2/1996	Mizuno et al.	5,827,757 A	10/1998	Robinson, Jr. et al.
5,496,408 A	3/1996	Motoda et al.	5,836,483 A	11/1998	Disel
5,501,740 A	3/1996	Besen et al.	5,837,058 A	11/1998	Chen et al.
5,503,875 A	4/1996	Imai et al.	5,837,320 A	11/1998	Hampden-Smith et al.
5,504,042 A	4/1996	Cho et al.	5,844,683 A	12/1998	Pavloski et al.
5,510,277 A	4/1996	Cunningham et al.	5,846,332 A	12/1998	Zhao et al.
5,514,439 A	5/1996	Sibley	5,851,294 A	12/1998	Young et al.
5,518,549 A	5/1996	Hellwig	5,852,879 A	12/1998	Schumaier
5,523,616 A	6/1996	Yasuhide	5,853,484 A	12/1998	Jeong
5,527,111 A	6/1996	Lysen et al.	D404,370 S	1/1999	Kimura
5,527,417 A	6/1996	Iida	D404,372 S	1/1999	Ishii
5,531,218 A	7/1996	Krebs	5,855,680 A	1/1999	Soininen et al.
5,531,835 A	7/1996	Fodor et al.	5,855,681 A	1/1999	Maydan et al.
5,540,898 A	7/1996	Davidson	5,857,777 A	1/1999	Schuh
5,558,717 A	9/1996	Zhao et al.	5,863,123 A	1/1999	Lee et al.
5,559,046 A	9/1996	Oishi et al.	5,865,205 A	2/1999	Wilmer
5,562,947 A	10/1996	White et al.	5,866,795 A	2/1999	Wang et al.
5,574,247 A	11/1996	Nishitani et al.	5,872,065 A	2/1999	Sivaramakrishnan
5,576,629 A	11/1996	Turner	5,873,942 A	2/1999	Park
5,577,331 A	11/1996	Suzuki	5,877,095 A	3/1999	Tamura et al.
5,583,736 A	12/1996	Anderson et al.	5,879,128 A	3/1999	Tietz et al.
5,586,585 A	12/1996	Bonora et al.	5,879,459 A	3/1999	Gadgil et al.
5,589,002 A	12/1996	Su	5,884,640 A	3/1999	Fishkin et al.
5,589,110 A	12/1996	Motoda et al.	5,893,741 A	4/1999	Huang
5,595,606 A	1/1997	Fujikawa et al.	D409,894 S	5/1999	McClurg
			5,904,170 A	5/1999	Harvey et al.
			D411,516 S	6/1999	Imafuku et al.
			5,908,672 A	6/1999	Ryu
			5,915,562 A	6/1999	Nyseth et al.

(56)

References Cited

U.S. PATENT DOCUMENTS

5,916,365 A	6/1999	Sherman	6,134,807 A	10/2000	Komino
D412,270 S	7/1999	Fredrickson	6,137,240 A	10/2000	Bogdan et al.
5,920,798 A	7/1999	Higuchi et al.	6,140,252 A	10/2000	Cho et al.
D412,512 S *	8/1999	Boisvert D15/140	6,143,082 A	11/2000	McInerney et al.
5,937,323 A	8/1999	Orczyk et al.	6,143,659 A	11/2000	Leem
5,939,886 A	8/1999	Turner et al.	6,148,761 A	11/2000	Majewski et al.
5,947,718 A	9/1999	Weaver	6,158,941 A	12/2000	Muka et al.
5,950,925 A	9/1999	Fukunaga et al.	6,160,244 A	12/2000	Ohashi
5,954,375 A	9/1999	Trickle et al.	6,161,500 A	12/2000	Kopacz et al.
5,961,775 A	10/1999	Fujimura	6,162,323 A	12/2000	Koshimizu et al.
5,968,275 A	10/1999	Lee et al.	6,174,809 B1	1/2001	Kang et al.
5,970,621 A	10/1999	Bazydola	6,178,918 B1	1/2001	Van Os et al.
5,975,492 A	11/1999	Brenes	6,180,979 B1	1/2001	Hofman et al.
5,979,506 A	11/1999	Aarseth	6,187,672 B1	2/2001	Zhao
5,982,931 A	11/1999	Ishimaru	6,187,691 B1	2/2001	Fukuda
5,984,391 A	11/1999	Vanderpot et al.	6,190,037 B1	2/2001	Das et al.
5,987,480 A	11/1999	Donohue et al.	6,190,457 B1	2/2001	Arai et al.
5,989,342 A	11/1999	Ikeda et al.	6,190,634 B1	2/2001	Lieber et al.
5,992,453 A	11/1999	Zimmer	6,191,399 B1	2/2001	Van Bilsen
5,997,588 A	12/1999	Goodwin	6,194,037 B1	2/2001	Terasaki et al.
5,997,768 A	12/1999	Scully	6,201,999 B1	3/2001	Jevtic
5,998,870 A	12/1999	Lee et al.	6,203,613 B1	3/2001	Gates et al.
6,000,732 A	12/1999	Scheler et al.	6,203,969 B1	3/2001	Ueda
6,001,267 A	12/1999	Van Os et al.	6,207,932 B1	3/2001	Yoo
D419,652 S	1/2000	Hall et al.	6,212,789 B1	4/2001	Kato
6,013,553 A	1/2000	Wallace	6,214,122 B1	4/2001	Thompson
6,013,920 A	1/2000	Gordon et al.	6,217,658 B1	4/2001	Orczyk et al.
6,015,459 A	1/2000	Jamison et al.	6,218,288 B1	4/2001	Li et al.
6,015,465 A	1/2000	Kholodenko et al.	6,225,020 B1	5/2001	Jung et al.
6,017,779 A	1/2000	Miyasaka	6,231,290 B1	5/2001	Kikuchi et al.
6,017,818 A	1/2000	Lu	6,235,858 B1	5/2001	Swarup et al.
6,024,799 A	2/2000	Chen	6,238,734 B1	5/2001	Senzaki et al.
6,035,101 A	3/2000	Sajoto et al.	6,241,822 B1	6/2001	Ide
6,035,804 A	3/2000	Arami et al.	6,242,359 B1	6/2001	Misra
6,042,652 A	3/2000	Hyun	6,243,654 B1	6/2001	Johnson et al.
6,044,860 A	4/2000	Nue	6,245,665 B1	6/2001	Yokoyama
6,045,260 A	4/2000	Schwartz et al.	6,247,245 B1	6/2001	Ishii
6,048,154 A	4/2000	Wytman	6,250,250 B1	6/2001	Maishev et al.
6,050,506 A	4/2000	Guo et al.	6,257,758 B1	7/2001	Culbertson
6,053,982 A	4/2000	Halpin et al.	6,264,467 B1	7/2001	Andreas et al.
6,053,983 A	4/2000	Saeki et al.	6,271,148 B1	8/2001	Kao
6,054,013 A	4/2000	Collins et al.	6,274,878 B1	8/2001	Li et al.
6,054,678 A	4/2000	Miyazaki	6,281,098 B1	8/2001	Wang
6,060,691 A	5/2000	Minami et al.	6,281,141 B1	8/2001	Das et al.
6,060,721 A	5/2000	Huang	6,284,050 B1	9/2001	Shi et al.
6,068,441 A	5/2000	Raaijmakers et al.	6,287,965 B1	9/2001	Kang et al.
6,072,163 A	6/2000	Armstrong et al.	6,287,988 B1	9/2001	Nagamine et al.
6,073,973 A	6/2000	Boscaljon et al.	6,293,700 B1	9/2001	Lund et al.
6,074,154 A	6/2000	Ueda et al.	D449,873 S	10/2001	Bronson
6,074,443 A	6/2000	Venkatesh	6,296,710 B1	10/2001	Allen et al.
6,079,356 A	6/2000	Umotoy et al.	6,296,909 B1	10/2001	Spitsberg
6,079,927 A	6/2000	Muka	6,299,133 B2	10/2001	Waragai et al.
6,083,321 A	7/2000	Lei et al.	6,302,964 B1	10/2001	Umotoy et al.
6,086,677 A	7/2000	Umotoy et al.	6,303,523 B2	10/2001	Cheung
6,091,062 A	7/2000	Pfahnl et al.	6,305,898 B1	10/2001	Yamagishi et al.
6,093,252 A	7/2000	Wengert et al.	6,311,016 B1	10/2001	Yanagawa et al.
6,093,253 A	7/2000	Lofgren	6,312,525 B1	11/2001	Bright et al.
6,095,083 A	8/2000	Rice et al.	6,315,512 B1	11/2001	Tabrizi et al.
6,096,267 A	8/2000	Kishkovich	6,316,162 B1	11/2001	Jung et al.
6,099,302 A	8/2000	Hong et al.	6,321,680 B2	11/2001	Cook et al.
6,102,565 A	8/2000	Kita et al.	D451,893 S	12/2001	Robson
6,104,011 A	8/2000	Juliano	D452,220 S	12/2001	Robson
6,104,401 A	8/2000	Parsons	6,325,858 B1	12/2001	Wengert
6,106,625 A	8/2000	Koai et al.	6,326,322 B1	12/2001	Kim et al.
6,106,678 A	8/2000	Shufflebotham	6,326,597 B1	12/2001	Lubomirsky et al.
6,119,710 A	9/2000	Brown	6,329,297 B1	12/2001	Balish
6,120,008 A	9/2000	Littman et al.	6,335,049 B1	1/2002	Basceri
6,121,061 A	9/2000	Van Bilsen et al.	6,342,427 B1	1/2002	Choi et al.
6,121,158 A	9/2000	Benchikha et al.	6,344,084 B1	2/2002	Koinuma et al.
6,122,036 A	9/2000	Yamasaki et al.	6,344,232 B1	2/2002	Jones et al.
6,124,600 A	9/2000	Moroishi et al.	6,346,419 B1	2/2002	Ryerson et al.
6,125,789 A	10/2000	Gupta et al.	6,347,636 B1	2/2002	Xia
6,126,848 A	10/2000	Li et al.	6,350,391 B1	2/2002	Livshits et al.
6,129,044 A	10/2000	Zhao et al.	6,352,049 B1	3/2002	Yin et al.
6,129,546 A	10/2000	Sada	6,352,945 B1	3/2002	Matsuki
			D455,024 S	4/2002	Mimick et al.
			6,367,410 B1	4/2002	Leahy et al.
			6,368,773 B1	4/2002	Jung et al.
			6,368,987 B1	4/2002	Kopacz et al.

(56)

References Cited

U.S. PATENT DOCUMENTS

6,370,796 B1	4/2002	Zucker	6,528,430 B2	3/2003	Kwan
6,372,583 B1	4/2002	Tyagi	6,528,767 B2	3/2003	Bagley et al.
6,374,831 B1	4/2002	Chandran	6,531,193 B2	3/2003	Fonash et al.
6,375,312 B1	4/2002	Ikeda et al.	6,531,412 B2	3/2003	Conti et al.
6,375,749 B1	4/2002	Boydston et al.	6,534,133 B1	3/2003	Kaloyeros et al.
6,375,750 B1	4/2002	Van Os et al.	6,534,395 B2	3/2003	Werkhoven et al.
6,379,466 B1	4/2002	Sahin et al.	6,536,950 B1	3/2003	Green
D457,609 S	5/2002	Piano	6,539,891 B1	4/2003	Kang et al.
6,383,566 B1	5/2002	Zagdoun	6,540,469 B2	4/2003	Matsunaga et al.
6,383,955 B1	5/2002	Matsuki	6,544,906 B2	4/2003	Rotondaro et al.
6,387,207 B1	5/2002	Janakiraman	6,552,209 B1	4/2003	Lei et al.
6,390,754 B2	5/2002	Yamaga et al.	6,558,517 B2	5/2003	Basceri
6,391,803 B1	5/2002	Kim et al.	6,558,755 B2	5/2003	Berry et al.
6,395,650 B1	5/2002	Callegari et al.	6,559,026 B1	5/2003	Rossman et al.
6,398,184 B1	6/2002	Sowada et al.	6,565,763 B1	5/2003	Asakawa et al.
6,410,459 B2	6/2002	Blalock et al.	6,566,278 B1	5/2003	Harvey et al.
6,413,321 B1	7/2002	Kim et al.	6,569,239 B2	5/2003	Arai et al.
6,413,583 B1	7/2002	Moghadam et al.	6,569,971 B2	5/2003	Roh et al.
6,420,279 B1	7/2002	Ono et al.	6,608,745 B2	5/2003	Tsuruta et al.
6,423,949 B1	7/2002	Chen et al.	6,573,030 B1	6/2003	Fairbairn et al.
D461,233 S	8/2002	Whalen	6,574,644 B2	6/2003	Hsu et al.
D461,882 S	8/2002	Piano	6,576,062 B2	6/2003	Matsuse
6,432,849 B1	8/2002	Endo et al.	6,576,064 B2	6/2003	Griffiths et al.
6,435,798 B1	8/2002	Satoh	6,576,300 B1	6/2003	Berry et al.
6,435,865 B1	8/2002	Tseng et al.	6,576,564 B2	6/2003	Agarwal
6,436,819 B1	8/2002	Zhang	6,578,589 B1	6/2003	Mayusumi
6,437,444 B2	8/2002	Andideh	6,579,833 B1	6/2003	McNallan et al.
6,438,502 B1	8/2002	Awtrey	6,580,050 B1	6/2003	Miller et al.
6,439,822 B1	8/2002	Kimura et al.	6,582,174 B1	6/2003	Hayashi
6,441,350 B1	8/2002	Stoddard et al.	6,583,048 B1	6/2003	Vincent et al.
6,445,574 B1	9/2002	Saw et al.	6,589,352 B1	7/2003	Yudovsky et al.
6,446,573 B2	9/2002	Hirayama et al.	6,589,707 B2	7/2003	Lee et al.
6,447,232 B1	9/2002	Davis et al.	6,589,868 B2	7/2003	Rossman
6,447,651 B1	9/2002	Ishikawa et al.	6,590,251 B2	7/2003	Kang et al.
6,448,192 B1	9/2002	Kaushik	6,594,550 B1	7/2003	Okrah
6,450,117 B1	9/2002	Murugesu et al.	6,596,653 B2	7/2003	Tan
6,450,757 B1	9/2002	Saeki	6,598,559 B1	7/2003	Vellore et al.
6,451,713 B1	9/2002	Tay et al.	6,607,868 B2	8/2003	Choi
6,454,860 B2	9/2002	Metzner et al.	6,607,948 B1	8/2003	Sugiyama et al.
6,455,098 B2	9/2002	Tran et al.	6,620,251 B2	9/2003	Kitano
6,455,225 B1	9/2002	Kong et al.	6,624,064 B1	9/2003	Sahin
6,455,445 B2	9/2002	Matsuki	6,627,268 B1	9/2003	Fair et al.
6,461,435 B1	10/2002	Littau et al.	6,627,503 B2	9/2003	Ma et al.
6,461,436 B1	10/2002	Campbell et al.	6,632,478 B2	10/2003	Gaillard et al.
6,468,924 B2	10/2002	Lee	6,633,364 B2	10/2003	Hayashi
6,471,779 B1	10/2002	Nishio et al.	6,635,117 B1	10/2003	Kinnard et al.
6,472,266 B1	10/2002	Yu et al.	6,638,839 B2	10/2003	Deng et al.
6,475,276 B1	11/2002	Elers et al.	6,645,304 B2	11/2003	Yamaguchi
6,475,930 B1	11/2002	Junker et al.	6,648,974 B1	11/2003	Ogliari et al.
6,478,872 B1	11/2002	Chae et al.	6,649,921 B1	11/2003	Cekic et al.
6,481,945 B1	11/2002	Hasper et al.	6,652,924 B2	11/2003	Sherman
6,482,331 B2	11/2002	Lu et al.	6,656,281 B1	12/2003	Ueda
6,482,663 B1	11/2002	Buckland	6,660,662 B2	12/2003	Ishikawa et al.
6,483,989 B1	11/2002	Okada et al.	6,662,817 B2	12/2003	Yamagishi
6,492,625 B1	12/2002	Boguslaskiy et al.	6,673,196 B1	1/2004	Oyabu
6,494,065 B2	12/2002	Babbitt	6,676,290 B1	1/2004	Lu
6,494,998 B1	12/2002	Brcka	6,682,971 B2	1/2004	Tsuneda et al.
6,496,819 B1	12/2002	Bello et al.	6,682,973 B1	1/2004	Paton et al.
6,497,734 B1	12/2002	Barber et al.	D486,891 S	2/2004	Cronce
6,498,091 B1	12/2002	Chen et al.	6,684,659 B1	2/2004	Tanaka et al.
6,499,533 B2	12/2002	Yamada	6,688,784 B1	2/2004	Templeton
6,502,530 B1	1/2003	Turlot et al.	6,689,220 B1	2/2004	Nguyen
6,503,079 B2	1/2003	Kogano et al.	6,692,575 B1	2/2004	Omstead et al.
6,503,365 B1	1/2003	Kim et al.	6,692,576 B2	2/2004	Halpin et al.
6,503,562 B1	1/2003	Saito et al.	6,696,367 B1	2/2004	Aggarwal
6,503,826 B1	1/2003	Oda	6,699,003 B2	3/2004	Saeki
6,506,009 B1	1/2003	Nulman et al.	6,699,399 B1	3/2004	Qian et al.
6,506,253 B2	1/2003	Sakuma	6,709,989 B2	3/2004	Ramdani et al.
6,507,410 B1	1/2003	Robertson et al.	6,710,364 B2	3/2004	Guldi et al.
6,511,539 B1	1/2003	Raaijmakers	6,710,857 B2	3/2004	Kondo
6,514,313 B1	2/2003	Spiegelman	6,713,824 B1	3/2004	Mikata
6,514,666 B1	2/2003	Choi et al.	6,716,571 B2	4/2004	Gabriel
6,521,295 B1	2/2003	Remington	6,720,260 B1	4/2004	Fair et al.
6,521,547 B1	2/2003	Chang et al.	6,722,837 B2	4/2004	Inui
6,527,884 B1	3/2003	Takakuwa et al.	6,723,642 B1	4/2004	Lim et al.
			6,730,614 B1	5/2004	Lim et al.
			6,732,006 B2	5/2004	Haanstra et al.
			6,734,090 B2	5/2004	Agarwala et al.
			6,740,853 B1	5/2004	Kitayama et al.

(56)

References Cited

U.S. PATENT DOCUMENTS

6,743,475 B2	6/2004	Skarp et al.	6,952,656 B1	10/2005	Cordova et al.
6,743,738 B2	6/2004	Todd et al.	6,953,609 B2	10/2005	Carollo
6,745,095 B1	6/2004	Ben-Dov	6,955,836 B2	10/2005	Kumagai et al.
6,746,308 B1	6/2004	Bode et al.	6,955,928 B1	10/2005	Brennan
6,753,507 B2	6/2004	Fure et al.	6,963,052 B2	11/2005	Kuibira et al.
6,755,221 B2	6/2004	Jeong et al.	6,972,055 B2	12/2005	Sferlazzo
6,756,085 B2	6/2004	Waldfried	6,972,478 B1	12/2005	Waite et al.
6,756,293 B2	6/2004	Li et al.	6,974,781 B2	12/2005	Timmermans et al.
6,756,318 B2	6/2004	Nguyen et al.	6,975,921 B2	12/2005	Verhaar
6,759,098 B2	7/2004	Han	6,976,822 B2	12/2005	Woodruff
6,760,981 B2	7/2004	Leap	6,981,832 B2	1/2006	Zinger et al.
D494,552 S	8/2004	Tezuka et al.	6,982,046 B2	1/2006	Srivastava et al.
6,784,108 B1	8/2004	Donohoe et al.	6,982,103 B2	1/2006	Basceri et al.
D496,008 S	9/2004	Takahashi et al.	6,984,591 B1	1/2006	Buchanan et al.
D497,977 S	11/2004	Engelbrektsson	6,984,595 B1	1/2006	Yamazaki
6,811,960 B2	11/2004	Lee et al.	6,985,788 B2	1/2006	Haanstra et al.
6,812,157 B1	11/2004	Gadgil	6,987,155 B2	1/2006	Roh et al.
6,815,350 B2	11/2004	Kim et al.	6,990,430 B2	1/2006	Hosek
6,815,352 B1	11/2004	Tamura et al.	7,005,227 B2	2/2006	Yueh et al.
6,820,570 B2	11/2004	Kilpela et al.	7,005,391 B2	2/2006	Min
6,821,910 B2	11/2004	Adomaitis et al.	7,010,580 B1	3/2006	Fu et al.
6,824,665 B2	11/2004	Shelnut et al.	7,017,514 B1	3/2006	Shepherd et al.
6,825,134 B2	11/2004	Law et al.	7,018,941 B2	3/2006	Cui et al.
D499,620 S *	12/2004	Horner-Richardson D8/30	7,021,881 B2	4/2006	Yamagishi
6,828,235 B2	12/2004	Takano	7,036,453 B2	5/2006	Ishikawa et al.
6,831,004 B2	12/2004	Byun	7,041,609 B2	5/2006	Vaartstra
6,835,039 B2	12/2004	Van Den Berg	7,045,430 B2	5/2006	Ahn et al.
6,838,122 B2	1/2005	Basceri et al.	7,049,226 B2	5/2006	Chung et al.
6,841,201 B2	1/2005	Shanov et al.	7,049,247 B2	5/2006	Gates et al.
6,846,146 B2	1/2005	Inui	7,052,584 B2	5/2006	Basceri
6,846,515 B2	1/2005	Vrtis	7,053,009 B2	5/2006	Conley, Jr. et al.
6,846,742 B2	1/2005	Rossmann	7,055,875 B2	6/2006	Bonora
6,847,014 B1	1/2005	Benjamin et al.	7,062,161 B2	6/2006	Kusuda et al.
6,858,524 B2	2/2005	Haukka et al.	7,070,178 B2	7/2006	Van Der Toorn et al.
6,858,547 B2	2/2005	Metzner	7,071,051 B1	7/2006	Jeon et al.
6,861,642 B2	3/2005	Ichiki et al.	7,073,834 B2	7/2006	Matsumoto et al.
6,863,019 B2	3/2005	Shamouilian	7,080,545 B2	7/2006	Dimeo et al.
6,863,281 B2	3/2005	Endou et al.	7,084,060 B1	8/2006	Furukawa
6,864,041 B2	3/2005	Brown	7,084,079 B2	8/2006	Conti et al.
6,867,859 B1	3/2005	Powell	7,085,623 B2	8/2006	Siegers
6,872,258 B2	3/2005	Park et al.	7,088,003 B2	8/2006	Gates et al.
6,872,259 B2	3/2005	Strang	7,090,394 B2	8/2006	Hashikura et al.
D504,142 S *	4/2005	Horner-Richardson D15/144	7,092,287 B2	8/2006	Beulens et al.
6,874,247 B1	4/2005	Hsu	7,098,149 B2	8/2006	Lukas
6,874,480 B1	4/2005	Ismailov	7,101,763 B1	9/2006	Anderson et al.
6,875,677 B1	4/2005	Conley, Jr. et al.	7,109,098 B1	9/2006	Ramaswamy et al.
6,876,017 B2	4/2005	Goodner	7,109,114 B2	9/2006	Chen et al.
6,876,191 B2	4/2005	de Ridder	7,111,232 B1	9/2006	Bascom
6,878,206 B2	4/2005	Tzu et al.	7,115,305 B2	10/2006	Bronikowski et al.
6,878,402 B2	4/2005	Chiang et al.	7,115,838 B2	10/2006	Kurara et al.
6,883,733 B1	4/2005	Lind	7,122,085 B2	10/2006	Shero et al.
6,884,066 B2	4/2005	Nguyen et al.	7,122,222 B2	10/2006	Xiao et al.
6,884,295 B2	4/2005	Ishii	7,129,165 B2	10/2006	Basol et al.
6,884,319 B2	4/2005	Kim	7,132,360 B2	11/2006	Schaeffer et al.
6,884,475 B2	4/2005	Basceri	7,135,421 B2	11/2006	Ahn et al.
D505,590 S	5/2005	Greiner	7,143,897 B1	12/2006	Guzman et al.
6,889,211 B1	5/2005	Yoshiura et al.	7,144,809 B2	12/2006	Elers et al.
6,889,864 B2	5/2005	Linclfors et al.	7,147,766 B2	12/2006	Uzoh et al.
6,895,158 B2	5/2005	Alyward et al.	7,153,542 B2	12/2006	Nguyen et al.
6,899,507 B2	5/2005	Yamagishi et al.	7,156,380 B2	1/2007	Soininen
6,909,839 B2	6/2005	Wang et al.	7,163,393 B2	1/2007	Adachi et al.
6,911,092 B2	6/2005	Sneh	7,163,721 B2	1/2007	Zhang et al.
6,913,152 B2	7/2005	Zuk	7,163,900 B2	1/2007	Weber
6,913,796 B2	7/2005	Albano et al.	7,168,852 B2	1/2007	Linnarsson
6,916,398 B2	7/2005	Chen et al.	7,172,497 B2	2/2007	Basol et al.
6,917,755 B2	7/2005	Nguyen et al.	7,186,648 B1	3/2007	Rozbicki
6,924,078 B2	8/2005	Lee et al.	7,192,824 B2	3/2007	Ahn et al.
6,929,700 B2	8/2005	Tan et al.	7,192,892 B2	3/2007	Ahn et al.
6,930,041 B2	8/2005	Agarwal	7,195,693 B2	3/2007	Cowans
6,930,059 B2	8/2005	Conley, Jr. et al.	D541,125 S *	4/2007	Gaudron D8/71
6,935,269 B2	8/2005	Lee et al.	7,198,447 B2	4/2007	Morimitsu et al.
6,939,817 B2	9/2005	Sandhu et al.	7,201,943 B2	4/2007	Park et al.
6,942,753 B2	9/2005	Choi et al.	7,202,512 B2	4/2007	Chen et al.
6,949,204 B1	9/2005	Lenz et al.	7,204,886 B2	4/2007	Chen et al.
6,951,587 B1	10/2005	Narushima	7,204,887 B2	4/2007	Kawamura et al.
			7,205,246 B2	4/2007	MacNeil et al.
			7,205,247 B2	4/2007	Lee et al.
			7,207,763 B2	4/2007	Lee
			7,208,198 B2	4/2007	Basceri et al.

(56)

References Cited

U.S. PATENT DOCUMENTS

7,208,389 B1	4/2007	Tipton et al.	7,429,532 B2	9/2008	Ramaswamy et al.
7,210,925 B2	5/2007	Adachi	7,431,966 B2	10/2008	Derderian et al.
7,211,524 B2	5/2007	Ryu et al.	7,432,476 B2	10/2008	Morita et al.
7,211,525 B1	5/2007	Shanker	7,437,060 B2	10/2008	Wang et al.
7,214,630 B1	5/2007	Varadarajan et al.	7,442,275 B2	10/2008	Cowans
7,217,617 B2	5/2007	Basceri	7,456,429 B2	11/2008	Levy
7,223,014 B2	5/2007	Lojen	D583,395 S	12/2008	Ueda
7,208,413 B2	6/2007	Byun et al.	7,467,632 B2	12/2008	Lee et al.
7,234,476 B2	6/2007	Arai	7,475,588 B2	1/2009	Dimeo et al.
7,235,137 B2	6/2007	Kitayama et al.	7,476,291 B2	1/2009	Wang et al.
7,235,482 B2	6/2007	Wu	7,479,198 B2	1/2009	Guffrey
7,235,501 B2	6/2007	Ahn et al.	7,482,247 B1	1/2009	Papasouliotis
7,238,596 B2	7/2007	Kouvetakis et al.	7,482,283 B2	1/2009	Yamasaki et al.
7,238,616 B2	7/2007	Agarwal	D585,968 S	2/2009	Elkins et al.
7,238,653 B2	7/2007	Lee et al.	7,489,389 B2	2/2009	Shibazaki et al.
7,265,061 B1	9/2007	Cho et al.	7,494,882 B2	2/2009	Vitale
7,274,867 B2	9/2007	Peukert	7,497,614 B2	3/2009	Gaff
D553,104 S	10/2007	Oohashi et al.	7,498,242 B2	3/2009	Kumar et al.
7,279,256 B2	10/2007	Son	7,501,292 B2	3/2009	Matsushita et al.
7,290,813 B2	11/2007	Bonora	7,501,355 B2	3/2009	Bhatia et al.
7,294,581 B2	11/2007	Haverkort et al.	7,503,980 B2	3/2009	Kida et al.
7,296,460 B2	11/2007	Dimeo et al.	7,504,344 B2	3/2009	Matsuki et al.
7,297,641 B2	11/2007	Todd et al.	D590,933 S	4/2009	Vansell
7,298,009 B2	11/2007	Yan et al.	7,514,058 B1	4/2009	Hitzman et al.
7,301,623 B1	11/2007	Madsen et al.	7,514,375 B1	4/2009	Shanker et al.
D556,704 S	12/2007	Nakamura et al.	7,541,297 B2	4/2009	Mallick et al.
D557,226 S	12/2007	Uchino et al.	D593,585 S	6/2009	Ota et al.
D558,021 S	12/2007	Lawrence	D593,969 S	6/2009	Li
7,307,028 B2	12/2007	Goto et al.	7,544,398 B1	6/2009	Chang et al.
7,307,178 B2	12/2007	Kiyomori et al.	7,547,363 B2	6/2009	Tomiyasu et al.
7,312,148 B2	12/2007	Ramaswamy et al.	7,547,633 B2	6/2009	Ranish et al.
7,312,162 B2	12/2007	Ramaswamy et al.	7,550,396 B2	6/2009	Frohberg et al.
7,312,494 B2	12/2007	Ahn et al.	D596,476 S *	7/2009	Welch D8/303
D559,993 S	1/2008	Nagakubo et al.	7,561,982 B2	7/2009	Rund et al.
D559,994 S	1/2008	Nagakubo et al.	7,563,715 B2	7/2009	Haukka et al.
7,320,544 B2	1/2008	Hsieh	7,566,891 B2	7/2009	Rocha-Alvarez et al.
7,323,401 B2	1/2008	Ramaswamy et al.	7,575,968 B2	8/2009	Sadaka et al.
7,326,656 B2	2/2008	Brask et al.	7,579,285 B2	8/2009	Zimmerman et al.
7,326,657 B2	2/2008	Xia et al.	7,579,785 B2	8/2009	DeVincentis et al.
7,327,948 B1	2/2008	Shrinivasan	D600,223 S	9/2009	Aggarwal
7,329,947 B2	2/2008	Adachi et al.	7,582,555 B1	9/2009	Lang
7,335,611 B2	2/2008	Ramaswamy et al.	7,582,575 B2	9/2009	Fukazawa et al.
7,351,057 B2	4/2008	Berenbak et al.	7,589,003 B2	9/2009	Kouvetakis et al.
7,354,847 B2	4/2008	Chan et al.	7,589,028 B1	9/2009	Cho et al.
7,354,873 B2	4/2008	Fukazawa et al.	7,589,029 B2	9/2009	Derderian et al.
7,356,762 B2	4/2008	van Driel	7,591,601 B2	9/2009	Matsuoka et al.
7,357,138 B2	4/2008	Ji et al.	D602,575 S	10/2009	Breda
7,361,447 B2	4/2008	Jung	7,598,513 B2	10/2009	Kouvetakis et al.
7,375,035 B2	5/2008	Heden et al.	7,601,223 B2	10/2009	Lindfors et al.
7,376,520 B2	5/2008	Wong	7,601,225 B2	10/2009	Tuominen et al.
7,379,785 B2	5/2008	Higashi et al.	7,601,652 B2	10/2009	Singh et al.
D571,383 S	6/2008	Ota et al.	7,611,751 B2	11/2009	Elers
D571,831 S	6/2008	Ota et al.	7,611,980 B2	11/2009	Wells et al.
7,381,644 B1	6/2008	Soubramonium et al.	7,618,226 B2	11/2009	Takizawa
7,387,685 B2	6/2008	Choi et al.	7,621,672 B2	11/2009	Ripley
7,393,207 B2	7/2008	Imai	7,622,369 B1	11/2009	Lee et al.
7,393,418 B2	7/2008	Yokogawa	7,622,378 B2	11/2009	Liu et al.
7,393,736 B2	7/2008	Ahn et al.	7,623,940 B2	11/2009	Huskamp et al.
7,393,765 B2	7/2008	Hanawa et al.	D606,952 S	12/2009	Lee
7,396,491 B2	7/2008	Marking et al.	7,625,820 B1	12/2009	Papasouliotis
7,399,388 B2	7/2008	Moghadam et al.	7,629,277 B2	12/2009	Ghatnagar
7,399,570 B2	7/2008	Lee et al.	7,632,549 B2	12/2009	Goundar
7,402,534 B2	7/2008	Mahajani	7,640,142 B2	12/2009	Tachikawa et al.
7,405,166 B2	7/2008	Liang et al.	7,645,341 B2	1/2010	Kennedy et al.
7,405,454 B2	7/2008	Ahn et al.	7,645,484 B2	1/2010	Ishizaka
D575,713 S	8/2008	Ratcliffe	7,648,927 B2	1/2010	Singh et al.
7,410,290 B2	8/2008	Tanaka	7,651,269 B2	1/2010	Comendant
7,410,666 B2	8/2008	Elers	7,651,583 B2	1/2010	Kent et al.
7,411,352 B2	8/2008	Madocks	7,651,955 B2	1/2010	Ravish et al.
7,414,281 B1	8/2008	Fastow	7,651,959 B2	1/2010	Fukazawa et al.
D576,001 S	9/2008	Brunderman	7,651,961 B2	1/2010	Clark
7,422,635 B2	9/2008	Zheng et al.	D609,652 S	2/2010	Munetoshi
7,422,636 B2	9/2008	Ishizaka	D609,655 S	2/2010	Sugimoto
7,422,653 B2	9/2008	Blahnik et al.	7,661,299 B2	2/2010	Kusunoki
7,422,775 B2	9/2008	Ramaswamy et al.	7,678,197 B2	3/2010	Maki
			7,678,715 B2	3/2010	Mungekar et al.
			7,682,454 B2	3/2010	Sneh
			7,682,657 B2	3/2010	Sherman
			D613,829 S	4/2010	Griffin et al.

(56)

References Cited

U.S. PATENT DOCUMENTS

D614,153 S	4/2010	Fondurulia et al.	7,919,416 B2	4/2011	Lee et al.
D614,267 S	4/2010	Breda	7,925,378 B2	4/2011	Gilchrist et al.
D614,268 S	4/2010	Breda	7,935,940 B1	5/2011	Smargiassi
D614,593 S	4/2010	Lee	7,939,447 B2	5/2011	Bauer et al.
7,690,881 B2	4/2010	Yamagishi	7,942,969 B2	5/2011	Riker et al.
7,691,205 B2	4/2010	Ikedo	7,946,762 B2	5/2011	Yednak
7,692,171 B2	4/2010	Kaszuba et al.	7,951,262 B2	5/2011	Koshiishi et al.
7,695,808 B2	4/2010	Tuma	7,955,516 B2	6/2011	Chandrachood
D616,394 S	5/2010	Sato	7,955,650 B2	6/2011	Tsuji
7,712,435 B2	5/2010	Yoshizaki et al.	7,957,708 B2	6/2011	Karschnia et al.
7,713,874 B2	5/2010	Milligan	7,963,736 B2	6/2011	Takizawa et al.
7,716,993 B2	5/2010	Ozawa et al.	7,967,913 B2	6/2011	Hua et al.
7,720,560 B2	5/2010	Menser et al.	7,972,980 B2	7/2011	Lee et al.
7,723,648 B2	5/2010	Tsukamoto et al.	7,977,256 B2	7/2011	Liu et al.
7,727,864 B2	6/2010	Elers	7,981,751 B2	7/2011	Zhu et al.
7,732,343 B2	6/2010	Niroomand et al.	D643,055 S	8/2011	Takahashi
7,736,437 B2	6/2010	Cadwell et al.	7,989,736 B2	8/2011	Park et al.
7,736,528 B2	6/2010	Okita et al.	7,992,318 B2	8/2011	Kawaji
7,740,437 B2	6/2010	de Ridder et al.	7,994,070 B1	8/2011	Dip et al.
7,740,705 B2	6/2010	Li	7,994,721 B2	8/2011	Espiau et al.
7,745,346 B2	6/2010	Hausmann et al.	7,997,795 B2	8/2011	Schwagerman et al.
7,748,760 B2	7/2010	Kushida	7,998,875 B2	8/2011	DeYoung
7,749,563 B2	7/2010	Zheng et al.	8,003,174 B2	8/2011	Fukazawa
7,753,584 B2	7/2010	Gambino et al.	8,003,919 B2	8/2011	Goto et al.
7,754,621 B2	7/2010	Putjkonen	8,004,198 B2	8/2011	Bakre et al.
7,758,698 B2	7/2010	Bang et al.	8,004,315 B2	9/2011	Nishimura
7,763,869 B2	7/2010	Matsushita et al.	8,020,315 B2	10/2011	Jeong
7,767,262 B2	8/2010	Clark	8,030,129 B2	10/2011	Gage et al.
7,771,796 B2	8/2010	Kohno et al.	8,033,771 B1	10/2011	Hayashi et al.
7,780,440 B2	8/2010	Shibagaki et al.	8,038,835 B2	10/2011	Kasai et al.
7,780,789 B2	8/2010	Wu et al.	8,041,197 B2	10/2011	Takizawa et al.
7,781,352 B2	8/2010	Fukazawa et al.	8,041,450 B2	10/2011	Liu et al.
7,789,559 B2	9/2010	Waser et al.	8,043,972 B1	10/2011	Yetter et al.
7,789,965 B2	9/2010	Matsushita et al.	8,046,193 B2	11/2011	Chung et al.
7,790,633 B1	9/2010	Tarafdar et al.	8,048,783 B2	11/2011	Numakura
7,798,096 B2	9/2010	Mahajani et al.	8,055,378 B2	11/2011	Gage et al.
7,799,706 B2	9/2010	Yeom et al.	8,060,252 B2	11/2011	Choi et al.
7,803,722 B2	9/2010	Liang	8,083,853 B2	11/2011	Nakashima et al.
D625,977 S	10/2010	Watson et al.	RE43,023 E	12/2011	Fujikata et al.
7,795,160 B2	10/2010	Wang et al.	D649,986 S	12/2011	Liebson et al.
7,806,587 B2	10/2010	Kobayashi	D651,291 S	12/2011	Uzoh
7,807,566 B2	10/2010	Tsuji et al.	8,071,451 B2	12/2011	Raisanen
7,807,578 B2	10/2010	Bencher et al.	8,071,452 B2	12/2011	Yasuda et al.
7,816,278 B2	10/2010	Reed et al.	8,072,578 B2	12/2011	Wei
7,824,492 B2	11/2010	Tois et al.	8,076,230 B2	12/2011	Uzoh
7,825,040 B1	11/2010	Fukazawa et al.	8,076,237 B2	12/2011	Rajagopalan
7,829,460 B2	11/2010	Streck et al.	8,076,250 B1	12/2011	Akae et al.
7,833,348 B2	11/2010	Wada et al.	8,076,251 B2	12/2011	Nishimoto et al.
7,833,353 B2	11/2010	Furukawahara et al.	8,078,310 B2	12/2011	Laverdiere et al.
7,838,084 B2	11/2010	Derderian et al.	8,082,946 B2	12/2011	Shinriki et al.
7,842,518 B2	11/2010	Miyajima	8,084,104 B2	12/2011	You et al.
7,842,622 B1	11/2010	Lee et al.	8,084,372 B2	1/2012	Gether
D629,874 S	12/2010	Hermans	D652,896 S	1/2012	Tomiyasu et al.
7,850,449 B2	12/2010	Yang et al.	8,092,604 B2	1/2012	Aggarwal
7,851,019 B2	12/2010	Tuominen et al.	8,100,583 B2	2/2012	Sisk
7,851,232 B2	12/2010	van Schravendijk et al.	D653,734 S	2/2012	Honma et al.
7,858,519 B2	12/2010	Liu et al.	D654,882 S	2/2012	Honma
7,858,533 B2	12/2010	Liu et al.	D654,884 S	2/2012	Toll
7,865,070 B2	1/2011	Nakamura	D655,055 S	2/2012	Hersey et al.
7,871,198 B2	1/2011	Rempe et al.	8,110,099 B2	2/2012	Yang et al.
7,874,726 B2	1/2011	Jacobs et al.	8,114,734 B2	2/2012	Avouris
7,884,918 B2	2/2011	Hattori	8,119,466 B2	3/2012	Honma et al.
7,888,233 B1	2/2011	Gauri	D655,260 S	3/2012	Honma et al.
7,894,474 B1	2/2011	Bell	D655,261 S	3/2012	Durham D8/355
D634,329 S	3/2011	Wastrom	D655,599 S *	3/2012	Balseanu et al.
D634,719 S	3/2011	Yasuda et al.	8,129,290 B2	3/2012	Fondurulia et al.
7,897,215 B1	3/2011	Fair et al.	8,137,462 B2	3/2012	Shrinivasan et al.
7,897,217 B2	3/2011	Faguet	8,137,465 B1	3/2012	Balseanu et al.
7,902,009 B2	3/2011	Simonelli et al.	8,138,104 B2	3/2012	Mills
7,902,582 B2	3/2011	Forbes et al.	8,138,676 B2	3/2012	Lee et al.
7,906,174 B1	3/2011	Wu et al.	8,142,862 B2	3/2012	Xia et al.
7,910,288 B2	3/2011	Abatchev et al.	8,143,174 B2	4/2012	Shibagaki et al.
7,915,139 B1	3/2011	Lang	8,147,242 B2	4/2012	Ji et al.
7,915,667 B2	3/2011	Knoefler et al.	8,158,512 B2	5/2012	Shibata et al.
7,919,142 B2	4/2011	Yeom et al.	8,172,947 B2	5/2012	Lee et al.
			8,173,554 B2	5/2012	King et al.
			8,178,436 B2	5/2012	Dickey et al.
			8,187,679 B2	5/2012	Wang
			8,187,951 B1	5/2012	Salvador
			8,272,516 B2		

(56)

References Cited

U.S. PATENT DOCUMENTS

8,192,901 B2	6/2012	Kageyama	8,608,885 B2	11/2013	Goto et al.
8,196,234 B2	6/2012	Glunk	D694,790 S	12/2013	Matsumoto et al.
8,197,915 B2	6/2012	Oka et al.	D695,240 S	12/2013	Iida et al.
8,198,168 B2	6/2012	Tanioku	8,614,047 B2	12/2013	Ayothi et al.
8,206,506 B2	6/2012	Kadkhodayan et al.	8,616,765 B2	12/2013	Darabnia et al.
8,216,380 B2	7/2012	White et al.	8,617,411 B2	12/2013	Singh
8,227,032 B2	7/2012	Dussarrat et al.	D697,038 S	1/2014	Matsumoto et al.
8,231,799 B2	7/2012	Hera et al.	8,633,115 B2	1/2014	Chang et al.
D665,055 S	8/2012	Yanagisawa et al.	D698,904 S	2/2014	Milligan et al.
8,241,991 B2	8/2012	Hsieh et al.	8,642,488 B2	2/2014	Liu et al.
8,241,992 B2	8/2012	Clevenger et al.	8,647,722 B2	2/2014	Kobayashi et al.
8,242,028 B1	8/2012	van Schravendijk	8,647,993 B2	2/2014	Lavoie et al.
8,242,031 B2	8/2012	Mallick et al.	8,651,788 B1 *	2/2014	Budde F16B 5/0233 411/535
8,246,900 B2	8/2012	Kasai et al.	8,664,627 B1	3/2014	Ishikawa et al.
8,252,114 B2	8/2012	Vukovic	8,667,654 B2	3/2014	Gros-Jean
8,252,659 B2	8/2012	Huyghabaert et al.	8,668,957 B2	3/2014	Dussarrat et al.
8,252,691 B2	8/2012	Beynet et al.	8,669,185 B2	3/2014	Onizawa
8,267,633 B2	9/2012	Obikane	8,679,958 B2	3/2014	Takamura et al.
8,278,176 B2	10/2012	Bauer et al.	D702,188 S	4/2014	Jacobs
8,282,769 B2	10/2012	Iizuka	8,683,943 B2	4/2014	Onodera et al.
8,282,847 B2	10/2012	Romano	8,710,580 B2	4/2014	Sakuma et al.
8,287,648 B2	10/2012	Reed et al.	8,711,338 B2	4/2014	Liu et al.
8,293,016 B2	10/2012	Bahng et al.	D705,745 S	5/2014	Kurs et al.
8,293,642 B2	10/2012	Kim	D705,762 S	5/2014	Yu
8,298,951 B1	10/2012	Nakano	8,664,127 B2	5/2014	Bhatia et al.
8,307,472 B1	11/2012	Saxon et al.	8,720,965 B2	5/2014	Hino et al.
8,309,173 B2	11/2012	Tuominen et al.	8,721,791 B2	5/2014	Choi et al.
8,323,413 B2	12/2012	Son	8,722,510 B2	5/2014	Watanabe et al.
8,328,939 B2	12/2012	Choi et al.	8,722,546 B2	5/2014	Fukazawa et al.
8,329,599 B2	12/2012	Fukazawa et al.	8,726,837 B2	5/2014	Patalay et al.
8,334,219 B2	12/2012	Lee et al.	8,728,832 B2	5/2014	Raisanen et al.
8,338,809 B2	12/2012	Yang et al.	8,728,956 B2	5/2014	Lavoie et al.
8,349,083 B2	1/2013	Takasuka et al.	8,741,062 B2	6/2014	Lindfors et al.
D676,943 S	2/2013	Kluss	8,742,668 B2	6/2014	Nakano et al.
8,367,528 B2	2/2013	Bauer et al.	8,759,223 B2	6/2014	Sapre et al.
8,372,204 B2	2/2013	Nakamura	D709,536 S	7/2014	Yoshimura et al.
8,378,464 B2	2/2013	Kato et al.	D709,537 S	7/2014	Kuwabara et al.
8,393,091 B2	3/2013	Kawamoto	8,764,085 B2	7/2014	Urabe
8,394,466 B2	3/2013	Hong et al.	8,771,807 B2	7/2014	Xiao et al.
8,398,773 B2	3/2013	Jdira et al.	8,779,502 B2	7/2014	Sakuma et al.
8,402,918 B2	3/2013	Kadkhodayan et al.	8,784,950 B2	7/2014	Fukazawa et al.
8,404,499 B2	3/2013	Moffatt	8,784,951 B2	7/2014	Fukazawa et al.
8,415,258 B2	4/2013	Akae	8,785,215 B2	7/2014	Kobayashi et al.
8,415,259 B2	4/2013	Lee et al.	8,785,311 B2	7/2014	Miyoshi
8,419,959 B2	4/2013	Bettencourt et al.	8,790,743 B1	7/2014	Omari
8,440,259 B2	5/2013	Chiang et al.	8,790,749 B2	7/2014	Omori et al.
8,444,120 B2	5/2013	Gregg et al.	8,802,201 B2	8/2014	Raisanen et al.
8,445,075 B2	5/2013	Xu et al.	8,809,170 B2	8/2014	Bauer
8,450,191 B2	5/2013	Wang	8,820,809 B2	9/2014	Ando et al.
8,465,811 B2	6/2013	Ueda	8,821,640 B2	9/2014	Cleary et al.
8,465,903 B2	6/2013	Weidman et al.	8,828,886 B2	9/2014	Samukawa et al.
8,466,411 B2	6/2013	Arai	8,841,182 B1	9/2014	Chen et al.
8,470,187 B2	6/2013	Ha	8,845,806 B2	9/2014	Aida et al.
8,484,846 B2	7/2013	Dhindsa	8,846,502 B2	9/2014	Haukka et al.
8,492,170 B2	7/2013	Xie et al.	D715,410 S	10/2014	Lohmann
8,496,377 B2	7/2013	Harr et al.	8,859,368 B2	10/2014	Deniz
8,496,756 B2	7/2013	Cruse et al.	8,860,955 B2	10/2014	Rodnick et al.
8,497,213 B2	7/2013	Yasui et al.	8,864,202 B1	10/2014	Schrammeyer
8,501,599 B2	8/2013	Ueno et al.	D716,742 S	11/2014	Jang et al.
8,506,162 B2	8/2013	Schick et al.	8,876,974 B2	11/2014	Wan
8,506,713 B2	8/2013	Takagi	8,877,655 B2	11/2014	Shero et al.
8,529,701 B2	9/2013	Morita	8,882,923 B2	11/2014	Saido et al.
8,535,767 B1	9/2013	Kimura	8,883,270 B2	11/2014	Shero et al.
D691,974 S	10/2013	Osada et al.	8,900,999 B1	12/2014	Wu et al.
8,551,892 B2	10/2013	Nakano	8,901,016 B2	12/2014	Jeongseok et al.
8,557,712 B1	10/2013	Antonelli et al.	8,911,553 B2	12/2014	Baluja et al.
8,562,272 B2	10/2013	Lenz	8,911,826 B2	12/2014	Adachi et al.
8,563,443 B2	10/2013	Fukazawa	8,912,101 B2	12/2014	Tsuji et al.
8,569,184 B2	10/2013	Oka	D720,838 S	1/2015	Yamagishi et al.
D693,200 S *	11/2013	Saunders D8/71	8,927,906 B2	1/2015	Tadokoro et al.
8,573,152 B2	11/2013	de la Llera et al.	8,933,375 B2	1/2015	Dunn et al.
8,573,154 B2	11/2013	Yorozuya	8,940,646 B1	1/2015	Chandrasekharan
8,586,484 B2	11/2013	Matsuyama et al.	D723,153 S	2/2015	Borkholder
8,591,659 B1	11/2013	Fang et al.	8,945,305 B2	2/2015	Marsh
8,592,005 B2	11/2013	Ueda	8,945,306 B2	2/2015	Tsuda
			8,945,339 B2	2/2015	Kakimoto
			8,946,830 B2	2/2015	Jung et al.
			8,956,971 B2	2/2015	Huakka

(56)

References Cited

U.S. PATENT DOCUMENTS

8,956,983 B2	2/2015	Swaminathan	9,245,742 B2	1/2016	Haukka
D723,330 S	3/2015	York	9,252,024 B2	2/2016	Lam et al.
D724,553 S	3/2015	Choi	9,252,238 B1	2/2016	Trevino et al.
D724,701 S	3/2015	Yamagishi et al.	9,257,274 B2	2/2016	Kang et al.
D725,168 S	3/2015	Yamagishi	9,263,298 B2	2/2016	Matsumoto et al.
8,967,608 B2	3/2015	Mitsumori et al.	9,267,204 B2	2/2016	Honma
8,974,868 B2	3/2015	Ishikawa et al.	9,267,850 B2	2/2016	Aggarwal
8,980,006 B2	3/2015	Huh et al.	D751,176 S	3/2016	Schoenherr et al.
8,986,456 B2	3/2015	Fondurulia et al.	9,281,277 B2	3/2016	Baek et al.
8,991,214 B2	3/2015	Hoshino et al.	9,284,642 B2	3/2016	Nakano
8,991,887 B2	3/2015	Shin et al.	9,287,273 B2	3/2016	Ragnarsson et al.
8,993,054 B2	3/2015	Jung et al.	9,297,705 B2	3/2016	Aggarwal
8,993,457 B1	3/2015	Ramkumar et al.	9,299,557 B2	3/2016	Tolle et al.
D726,365 S	4/2015	Weigensberg	9,299,595 B2	3/2016	Dunn et al.
D726,884 S	4/2015	Yamagishi et al.	D753,269 S	4/2016	Yamagishi et al.
8,999,102 B2	4/2015	Miyoshi et al.	D753,629 S	4/2016	Plattard
9,004,744 B1	4/2015	Kemp	9,305,836 B1	4/2016	Gates et al.
9,005,539 B2	4/2015	Halpin et al.	9,309,598 B2	4/2016	Wang et al.
9,017,481 B1	4/2015	Pettinger et al.	9,309,978 B2	4/2016	Hatch et al.
9,017,933 B2	4/2015	Liu et al.	9,312,155 B2	4/2016	Mori
9,018,093 B2	4/2015	Tsuji et al.	9,315,897 B2	4/2016	Byun
9,018,111 B2	4/2015	Milligan et al.	9,324,811 B2	4/2016	Weeks
9,018,567 B2	4/2015	de Ridder et al.	9,324,846 B1	4/2016	Camillo
9,021,985 B2	5/2015	Alokozai et al.	9,337,054 B2	5/2016	Hunks et al.
9,023,737 B2	5/2015	Beynet et al.	9,337,057 B2	5/2016	Park et al.
9,023,738 B2	5/2015	Kato et al.	9,341,296 B2	5/2016	Yednak
9,029,244 B2	5/2015	Won et al.	9,343,297 B1	5/2016	Fukazawa et al.
9,029,253 B2	5/2015	Milligan et al.	9,343,308 B2	5/2016	Isii
9,029,272 B1	5/2015	Nakano	9,343,343 B2	5/2016	Mori
D732,145 S	6/2015	Yamagishi	9,343,350 B2	5/2016	Arai
D732,644 S	6/2015	Yamagishi et al.	9,349,620 B2	5/2016	Kamata et al.
D733,257 S	6/2015	Schoenherr et al.	9,353,441 B2	5/2016	Chung
D733,261 S	6/2015	Yamagishi et al.	9,355,876 B2	5/2016	Rejuter et al.
D733,262 S	6/2015	Kang	9,362,137 B2	6/2016	Kang et al.
D733,843 S	7/2015	Yamagishi	9,362,180 B2	6/2016	Lee et al.
D734,377 S	7/2015	Hirakida	9,365,924 B2	6/2016	Nonaka
9,076,726 B2	7/2015	Kauerauf et al.	9,368,352 B2	6/2016	Takamure et al.
D735,836 S	8/2015	Yamagishi	9,370,863 B2	6/2016	Tsuji et al.
D736,348 S	8/2015	Tan	9,384,987 B2	7/2016	Jung et al.
9,096,931 B2	8/2015	Yednak et al.	9,390,909 B2	7/2016	Pasquale et al.
9,099,423 B2	8/2015	Weeks et al.	9,394,608 B2	7/2016	Shero et al.
9,099,505 B2	8/2015	Kusakabe et al.	9,396,934 B2	7/2016	Tolle
9,111,972 B2	8/2015	Takeshita et al.	9,396,956 B1	7/2016	Fukazawa
9,117,657 B2	8/2015	Nakano et al.	9,399,228 B2	7/2016	Breiling et al.
9,117,866 B2	8/2015	Marquardt et al.	D764,196 S *	8/2016	Handler D6/352
D739,222 S	9/2015	Chadbourne	9,404,587 B2	8/2016	Shugrue
9,123,510 B2	9/2015	Nakano et al.	9,412,564 B2	8/2016	Milligan
9,123,577 B2	9/2015	Fujimoto et al.	9,412,582 B2	8/2016	Sasaki et al.
9,127,358 B2	9/2015	Inoue et al.	9,425,078 B2	8/2016	Tang et al.
9,129,897 B2	9/2015	Pore et al.	9,443,725 B2	9/2016	Liu et al.
9,136,108 B2	9/2015	Matsushita et al.	9,447,498 B2	9/2016	Shiba et al.
9,136,180 B2	9/2015	Machkaoutsan	9,449,793 B2	9/2016	Shaji et al.
9,142,393 B2	9/2015	Okabe et al.	9,455,138 B1	9/2016	Fukazawa
9,142,437 B2	9/2015	Fosnight et al.	9,455,177 B1	9/2016	Park et al.
9,153,441 B2	10/2015	Takamure et al.	9,464,352 B2	10/2016	Nakano et al.
9,166,012 B2	10/2015	Sim et al.	9,474,163 B2	10/2016	Tolle et al.
9,169,975 B2	10/2015	Sarin et al.	9,478,414 B2	10/2016	Kobayashi et al.
9,171,714 B2	10/2015	Mori	9,478,415 B2	10/2016	Kimura
9,171,716 B2	10/2015	Fukuda	D770,993 S	11/2016	Yoshida et al.
D742,202 S	11/2015	Cyphers et al.	9,484,191 B2	11/2016	Winkler
D743,357 S	11/2015	Vyne	9,514,927 B2	12/2016	Tolle et al.
D743,513 S	11/2015	Yamagishi	9,514,932 B2	12/2016	Mallick et al.
9,174,178 B2	11/2015	Yudovsky et al.	9,523,148 B1	12/2016	Pore et al.
9,175,394 B2	11/2015	Berger et al.	D777,546 S *	1/2017	Ishii D8/71
9,177,784 B2	11/2015	Raisanen et al.	9,543,180 B2	1/2017	Kamiya
9,184,047 B2	11/2015	Liu et al.	9,556,516 B2	1/2017	Takamure
9,184,054 B1	11/2015	Huang et al.	9,558,931 B2	1/2017	Tang
9,190,263 B2	11/2015	Ishikawa et al.	9,564,314 B2	2/2017	Takamure et al.
9,190,264 B2	11/2015	Yuasa et al.	9,570,302 B1	2/2017	Chang et al.
9,196,483 B1	11/2015	Lee et al.	9,574,268 B1	2/2017	Dunn et al.
D745,641 S	12/2015	Blum	9,576,952 B2	2/2017	Joshi et al.
9,202,727 B2	12/2015	Dunn et al.	9,583,345 B2	2/2017	Chen et al.
9,214,333 B1	12/2015	Sims et al.	9,589,770 B2	3/2017	Winkler
9,228,259 B2	1/2016	Haukka et al.	9,605,342 B2	3/2017	Alokozai et al.
9,240,412 B2	1/2016	Xie et al.	9,605,343 B2	3/2017	Winkler
			9,607,837 B1	3/2017	Namba
			D783,351 S	4/2017	Fujino et al.
			9,613,801 B2	4/2017	Carcasi et al.
			9,627,221 B1	4/2017	Zaitso et al.

(56)

References Cited

U.S. PATENT DOCUMENTS

D785,766 S	5/2017	Sato	10,032,792 B2	7/2018	Kim et al.
D787,458 S	5/2017	Kim et al.	10,043,661 B2	8/2018	Kato et al.
9,640,416 B2	5/2017	Arai	10,047,435 B2	8/2018	Haukka et al.
9,640,448 B2	5/2017	Ikegawa et al.	10,053,774 B2	8/2018	Tolle et al.
9,647,114 B2	5/2017	Margetis	10,060,473 B2	8/2018	Davey et al.
9,657,845 B2	5/2017	Shugrue	D827,592 S	9/2018	Ichino et al.
9,659,799 B2	5/2017	Lawson	10,083,836 B2	9/2018	Milligan
9,663,857 B2	5/2017	Nakano et al.	D830,981 S	10/2018	Jeong et al.
9,666,528 B1	5/2017	Bergendahl et al.	10,087,522 B2	10/2018	Raisanen et al.
D789,888 S	6/2017	Jang et al.	10,087,525 B2	10/2018	Schmotzer et al.
9,684,234 B2	6/2017	Darling et al.	10,090,316 B2	10/2018	Ootsuka
9,685,320 B2	6/2017	Kang et al.	10,103,040 B1	10/2018	Oosterlaken et al.
9,691,771 B2	6/2017	Lansalot-Matras	10,106,892 B1	10/2018	Siddiqui et al.
9,698,031 B2	7/2017	Kobayashi et al.	10,121,671 B2	11/2018	Fu et al.
9,708,707 B2	7/2017	Ditizio et al.	10,134,757 B2	11/2018	Chun et al.
9,708,708 B2	7/2017	Isobe et al.	RE47,170 E	12/2018	Beynet et al.
9,711,345 B2	7/2017	Shiba et al.	10,147,600 B2	12/2018	Takamure et al.
D793,352 S	8/2017	Hill	10,167,557 B2	1/2019	Hawkins et al.
D793,572 S	8/2017	Kozuka et al.	10,177,025 B2	1/2019	Pore
D793,976 S	8/2017	Fukushima et al.	10,179,947 B2	1/2019	Fukazawa
D795,208 S	8/2017	Sasaki et al.	10,186,420 B2	1/2019	Fukazawa
9,735,024 B2	8/2017	Zaitso	10,190,213 B2	1/2019	Zhu et al.
9,741,559 B2	8/2017	Shimura et al.	10,193,429 B2	1/2019	Smith et al.
9,748,145 B1	8/2017	Kannan et al.	D840,364 S	2/2019	Ichino et al.
D796,458 S	9/2017	Jang et al.	10,211,308 B2	2/2019	Zhu et al.
D796,670 S *	9/2017	Dolk D24/130	10,229,833 B2	3/2019	Raisanen et al.
9,754,779 B1	9/2017	Ishikawa	10,236,177 B1	3/2019	Kohen et al.
9,754,818 B2	9/2017	Shiu et al.	10,249,524 B2	4/2019	den Hartog Besselink et al.
9,759,489 B2	9/2017	Kaneko	10,249,577 B2	4/2019	Lee et al.
9,786,491 B2	10/2017	Suzuki et al.	10,262,859 B2	4/2019	Margetis et al.
9,790,595 B2	10/2017	Jung et al.	10,269,558 B2	4/2019	Blanquart et al.
9,793,115 B2	10/2017	Tolle	10,276,355 B2	4/2019	White et al.
9,793,135 B1	10/2017	Zaitso et al.	D849,662 S *	5/2019	Rike D12/223
9,793,148 B2	10/2017	Yamagishi et al.	10,283,353 B2	5/2019	Kobayashi et al.
9,798,308 B2	10/2017	Mimura	10,290,508 B1	5/2019	Kubota et al.
9,799,736 B1	10/2017	Ebrish et al.	10,312,055 B2	6/2019	Suzuki
D802,546 S	11/2017	Jang et al.	10,312,129 B2	6/2019	Coomer
9,808,246 B2	11/2017	Shelton et al.	10,319,588 B2	6/2019	Mattinen et al.
9,812,319 B1	11/2017	Fukazawa et al.	10,322,384 B2	6/2019	Stumpf et al.
9,812,320 B1	11/2017	Pore et al.	D855,089 S *	7/2019	Hopkins D15/138
9,820,289 B1	11/2017	Pawar et al.	10,340,125 B2	7/2019	Winkler
9,824,893 B1	11/2017	Smith et al.	10,340,135 B2	7/2019	Blanquart
D808,254 S *	1/2018	Deleu D8/382	10,343,920 B2	7/2019	Haukka
9,859,151 B1	1/2018	Niskanen	10,347,547 B2	7/2019	Varadarajan et al.
9,865,455 B1	1/2018	Sims et al.	10,361,201 B2	7/2019	Xie et al.
9,865,815 B2	1/2018	Hausmann	10,395,917 B2	8/2019	Niskanen et al.
9,868,131 B2	1/2018	Kilpi et al.	10,395,919 B2	8/2019	Masaru et al.
9,870,964 B1	1/2018	Yoshino et al.	D859,136 S *	9/2019	Tenander D8/394
9,875,891 B2	1/2018	Henri et al.	D867,867 S *	11/2019	Tenander D8/394
9,875,893 B2	1/2018	Takamure et al.	2001/0000141 A1	4/2001	Zhou et al.
D810,705 S	2/2018	Krishnan et al.	2001/0001953 A1	5/2001	Griffiths et al.
9,887,082 B1	2/2018	Pore et al.	2001/0003191 A1	6/2001	Kovacs et al.
9,890,456 B2	2/2018	Tolle et al.	2001/0004880 A1	6/2001	Cho et al.
9,891,521 B2	2/2018	Kang et al.	2001/0006070 A1	7/2001	Shang
9,892,908 B2	2/2018	Pettinger et al.	2001/0007645 A1	7/2001	Honma
9,892,913 B2	2/2018	Margetis et al.	2001/0014267 A1	8/2001	Yamaga et al.
9,895,715 B2	2/2018	Haukka et al.	2001/0014514 A1	8/2001	Geusic
9,899,291 B2	2/2018	Kato	2001/0017103 A1	8/2001	Takeshita et al.
9,899,405 B2	2/2018	Kim	2001/0018267 A1	8/2001	Shinriki et al.
9,905,420 B2	2/2018	Margetis et al.	2001/0019777 A1	9/2001	Tanaka et al.
9,909,492 B2	2/2018	Tang	2001/0019900 A1	9/2001	Hasegawa
9,909,214 B2	3/2018	Suemori	2001/0020715 A1	9/2001	Yamasaki
9,911,676 B2	3/2018	Tang	2001/0028924 A1	10/2001	Sherman
9,916,980 B1	3/2018	Knaepen	2001/0031535 A1	10/2001	Agnello et al.
9,929,011 B2	3/2018	Hawryluk et al.	2001/0031541 A1	10/2001	Madan et al.
9,951,421 B2	4/2018	Lind	2001/0038783 A1	11/2001	Nakashima et al.
9,960,072 B2	5/2018	Coomer	2001/0039922 A1	11/2001	Nakahara
9,984,869 B1	5/2018	Blanquart	2001/0039966 A1	11/2001	Walpole et al.
D819,580 S	6/2018	Krishnan et al.	2001/0040511 A1	11/2001	Bushner et al.
9,987,747 B2	6/2018	Hwang et al.	2001/0041250 A1	11/2001	Werkhoven et al.
9,997,357 B2	6/2018	Arghavani et al.	2001/0042511 A1	11/2001	Liu et al.
9,997,373 B2	6/2018	Hudson	2001/0046765 A1	11/2001	Cappellani et al.
10,032,628 B2	6/2018	Xie et al.	2001/0048981 A1	12/2001	Suzuki
10,018,920 B2	7/2018	Chang et al.	2001/0049080 A1	12/2001	Asano
10,023,960 B2	7/2018	Alokozai	2001/0049202 A1	12/2001	Maeda et al.
			2001/0054388 A1	12/2001	Qian
			2002/0001974 A1	1/2002	Chan
			2002/0001976 A1	1/2002	Danek
			2002/0005400 A1	1/2002	Gat et al.

(56)

References Cited

U.S. PATENT DOCUMENTS

2002/0008270	A1	1/2002	Marsh	2003/0017265	A1	1/2003	Basceri et al.
2002/0009119	A1	1/2002	Matthew et al.	2003/0017266	A1	1/2003	Basceri et al.
2002/0011210	A1	1/2002	Satoh et al.	2003/0017268	A1	1/2003	Hu
2002/0011211	A1	1/2002	Halpin	2003/0019428	A1	1/2003	Ku et al.
2002/0013792	A1	1/2002	Imielinski et al.	2003/0019580	A1	1/2003	Strang
2002/0014204	A1	2/2002	Pyo	2003/0022468	A1	1/2003	Shioya et al.
2002/0014483	A1	2/2002	Suzuki et al.	2003/0022523	A1	1/2003	Irino et al.
2002/0016829	A1	2/2002	Defosse	2003/0023338	A1	1/2003	Chin et al.
2002/0020429	A1	2/2002	Selbrede et al.	2003/0024901	A1	2/2003	Ishikawa
2002/0023677	A1	2/2002	Zheng	2003/0025146	A1	2/2003	Narwankar et al.
2002/0025688	A1	2/2002	Kato	2003/0029303	A1	2/2003	Hasegawa et al.
2002/0027945	A1	3/2002	Hirano et al.	2003/0029381	A1	2/2003	Nishibayashi
2002/0030047	A1	3/2002	Shao et al.	2003/0029475	A1	2/2003	Hua et al.
2002/0031644	A1	3/2002	Malofsky et al.	2003/0035002	A1	2/2003	Moles
2002/0041931	A1	4/2002	Suntola et al.	2003/0036272	A1	2/2003	Shamouilian et al.
2002/0043337	A1	4/2002	Goodman et al.	2003/0040120	A1	2/2003	Allen et al.
2002/0048634	A1	4/2002	Basceri	2003/0040158	A1	2/2003	Saitoh
2002/0081826	A1	4/2002	Rotondaro et al.	2003/0040196	A1	2/2003	Lim et al.
2002/0064592	A1	5/2002	Datta et al.	2003/0040841	A1	2/2003	Nasr et al.
2002/0064598	A1	5/2002	Wang et al.	2003/0041971	A1	3/2003	Kido et al.
2002/0069222	A1	6/2002	McNeely	2003/0042419	A1	3/2003	Katsumata et al.
2002/0073922	A1	6/2002	Frankel et al.	2003/0045961	A1	3/2003	Nakao
2002/0076507	A1	6/2002	Chiang et al.	2003/0049372	A1	3/2003	Cook et al.
2002/0076944	A1	6/2002	Wang et al.	2003/0049375	A1	3/2003	Nguyen et al.
2002/0078893	A1	6/2002	Os et al.	2003/0049937	A1	3/2003	Suzuki
2002/0079714	A1	6/2002	Soucy et al.	2003/0054670	A1	3/2003	Wang et al.
2002/0088542	A1	7/2002	Nishikawa et al.	2003/0057848	A1	3/2003	Yuasa et al.
2002/0090735	A1	7/2002	Kishkovich et al.	2003/0059535	A1	3/2003	Luo et al.
2002/0096211	A1	7/2002	Zheng	2003/0059980	A1	3/2003	Chen et al.
2002/0098627	A1	7/2002	Pomarede et al.	2003/0062359	A1	4/2003	Ho et al.
2002/0099470	A1	7/2002	Zinger et al.	2003/0065413	A1	4/2003	Liteplo et al.
2002/0100418	A1	8/2002	Sandhu et al.	2003/0066482	A1	4/2003	Pokharna et al.
2002/0104751	A1	8/2002	Drewery et al.	2003/0066541	A1	4/2003	Sun et al.
2002/0108670	A1	8/2002	Baker et al.	2003/0066826	A1	4/2003	Lee et al.
2002/0109115	A1	8/2002	Cederstav et al.	2003/0071015	A1	4/2003	Chinn et al.
2002/0110695	A1	8/2002	Yang et al.	2003/0072882	A1	4/2003	Niinisto et al.
2002/0110991	A1	8/2002	Li	2003/0075925	A1	4/2003	Lindfors et al.
2002/0112114	A1	8/2002	Blair et al.	2003/0077857	A1	4/2003	Xia et al.
2002/0114886	A1	8/2002	Chou et al.	2003/0077883	A1	4/2003	Ohtake
2002/0115252	A1	8/2002	Haukka et al.	2003/0082296	A1	5/2003	Elers et al.
2002/0123237	A1	9/2002	Nguyen et al.	2003/0082307	A1	5/2003	Chung et al.
2002/0124883	A1	9/2002	Zheng	2003/0085663	A1	5/2003	Horsky
2002/0127350	A1	9/2002	Ishikawa et al.	2003/0091938	A1	5/2003	Fairbairn et al.
2002/0132408	A1	9/2002	Ma et al.	2003/0094133	A1	5/2003	Yoshidome et al.
2002/0134511	A1	9/2002	Ushioda et al.	2003/0101938	A1	6/2003	Ronsse et al.
2002/0136214	A1	9/2002	Do et al.	2003/0109107	A1	6/2003	Hsieh et al.
2002/0136909	A1	9/2002	Yang	2003/0109951	A1	6/2003	Hsiung et al.
2002/0139775	A1	10/2002	Chang	2003/0111013	A1	6/2003	Oosterlaken et al.
2002/0146512	A1	10/2002	Rossman	2003/0111963	A1	6/2003	Tolmachev et al.
2002/0151327	A1	10/2002	Levitt	2003/0116087	A1	6/2003	Nguyen
2002/0152244	A1	10/2002	Dean et al.	2003/0168750	A1	6/2003	Basceri et al.
2002/0155219	A1	10/2002	Wang et al.	2003/0121608	A1	7/2003	Chen
2002/0160112	A1	10/2002	Sakai et al.	2003/0124792	A1	7/2003	Jeon et al.
2002/0164420	A1	11/2002	Derderian et al.	2003/0133854	A1	7/2003	Tabata et al.
2002/0172768	A1	11/2002	Endo et al.	2003/0134038	A1	7/2003	Paranjpe
2002/0174106	A1	11/2002	Martin	2003/0140851	A1	7/2003	Janakiraman et al.
2002/0179011	A1	12/2002	Jonnalagadda et al.	2003/0141820	A1	7/2003	White et al.
2002/0184111	A1	12/2002	Swanson	2003/0143328	A1	7/2003	Chen
2002/0187650	A1	12/2002	Blalock et al.	2003/0153177	A1	8/2003	Tepman et al.
2002/0187656	A1	12/2002	Tan et al.	2003/0153186	A1	8/2003	Bar-Gadda
2002/0197849	A1	12/2002	Mandal	2003/0157436	A1	8/2003	Manger et al.
2003/0000647	A1	1/2003	Yudovsky et al.	2003/0159656	A1	8/2003	Tan
2003/0002562	A1	1/2003	Yerlikaya et al.	2003/0162412	A1	8/2003	Chung
2003/0003607	A1	1/2003	Kagoshima	2003/0168001	A1	9/2003	Sneh
2003/0003635	A1	1/2003	Paranjpe et al.	2003/0168699	A1	9/2003	Honda
2003/0003696	A1	1/2003	Gelatos et al.	2003/0170153	A1	9/2003	Bar-Gadda
2003/0003719	A1	1/2003	Lim et al.	2003/0170583	A1	9/2003	Nakashima
2003/0008528	A1	1/2003	Xia et al.	2003/0170945	A1	9/2003	Igeta
2003/0010355	A1	1/2003	Nowak et al.	2003/0173490	A1	9/2003	Lappen
2003/0010451	A1	1/2003	Tzu	2003/0176074	A1	9/2003	Paterson et al.
2003/0010452	A1	1/2003	Park et al.	2003/0180458	A1	9/2003	Sneh
2003/0012632	A1	1/2003	Saeki	2003/0183156	A1	10/2003	Dando
2003/0015141	A1	1/2003	Takagi	2003/0183856	A1	10/2003	Wieczorek et al.
2003/0015294	A1	1/2003	Wang	2003/0188685	A1	10/2003	Wang
2003/0015596	A1	1/2003	Evans	2003/0190804	A1	10/2003	Glenn et al.
				2003/0192875	A1	10/2003	Bieker et al.
				2003/0198587	A1	10/2003	Kaloyeros
				2003/0201541	A1	10/2003	Kim
				2003/0205202	A1	11/2003	Funaki et al.

(56)

References Cited

U.S. PATENT DOCUMENTS

2003/0209323	A1	11/2003	Yokogaki	2004/0142577	A1	7/2004	Sugawara et al.
2003/0209326	A1	11/2003	Lee et al.	2004/0144311	A1	7/2004	Chen
2003/0209746	A1	11/2003	Horii	2004/0144980	A1	7/2004	Ahn et al.
2003/0210901	A1	11/2003	Donald et al.	2004/0146644	A1	7/2004	Xia et al.
2003/0211735	A1	11/2003	Rossman	2004/0151844	A1	8/2004	Zhang et al.
2003/0213435	A1	11/2003	Okuda et al.	2004/0151845	A1	8/2004	Nguyen et al.
2003/0213560	A1	11/2003	Wang et al.	2004/0152287	A1	8/2004	Sherrill et al.
2003/0217915	A1	11/2003	Ouellet	2004/0159343	A1	8/2004	Shimbara et al.
2003/0219972	A1	11/2003	Green	2004/0168627	A1	9/2004	Conley et al.
2003/0226840	A1	12/2003	Dalton	2004/0169032	A1	9/2004	Murayama et al.
2003/0228772	A1	12/2003	Cowans	2004/0185177	A1	9/2004	Basceri et al.
2003/0230986	A1	12/2003	Horsky et al.	2004/0187777	A1	9/2004	Okamoto et al.
2003/0231698	A1	12/2003	Yamaguchi	2004/0187784	A1	9/2004	Sferlazzo
2003/0232138	A1	12/2003	Tuominen et al.	2004/0187790	A1	9/2004	Bader
2003/0232491	A1	12/2003	Yamaguchi	2004/0187928	A1	9/2004	Ambrosina
2003/0232511	A1	12/2003	Metzner et al.	2004/0198069	A1	10/2004	Metzner et al.
2003/0234371	A1	12/2003	Ziegler	2004/0200499	A1	10/2004	Harvey et al.
2004/0002224	A1	1/2004	Chono et al.	2004/0202786	A1	10/2004	Wongsenakhum et al.
2004/0005147	A1	1/2004	Wang et al.	2004/0203251	A1	10/2004	Kawaguchi et al.
2004/0009307	A1	1/2004	Koh et al.	2004/0206305	A1	10/2004	Choi et al.
2004/0009679	A1	1/2004	Yeo et al.	2004/0209477	A1	10/2004	Buxbaum et al.
2004/0010772	A1	1/2004	McKenna et al.	2004/0211357	A1	10/2004	Gadgil
2004/0011504	A1	1/2004	Ku et al.	2004/0212947	A1	10/2004	Nguyen
2004/0013577	A1	1/2004	Ganguli et al.	2004/0213921	A1	10/2004	Leu
2004/0013818	A1	1/2004	Moon et al.	2004/0214399	A1	10/2004	Ahn et al.
2004/0015300	A1	1/2004	Ganguli et al.	2004/0214445	A1	10/2004	Shimizu et al.
2004/0016637	A1	1/2004	Yang	2004/0217217	A1	11/2004	Han et al.
2004/0018304	A1	1/2004	Chung et al.	2004/0219793	A1	11/2004	Hishiya et al.
2004/0018307	A1	1/2004	Park et al.	2004/0220699	A1	11/2004	Heden et al.
2004/0018723	A1	1/2004	Byun et al.	2004/0221807	A1	11/2004	Verghese et al.
2004/0018750	A1	1/2004	Sophie et al.	2004/0223893	A1	11/2004	Tabata et al.
2004/0023516	A1	2/2004	Londergan et al.	2004/0228968	A1	11/2004	Basceri
2004/0025787	A1	2/2004	Selbrede et al.	2004/0231600	A1	11/2004	Lee
2004/0026372	A1	2/2004	Takenaka et al.	2004/0238523	A1	12/2004	Kuibira et al.
2004/0029052	A1	2/2004	Park et al.	2004/0241322	A1	12/2004	Basceri et al.
2004/0031564	A1	2/2004	Gottscho et al.	2004/0241998	A1	12/2004	Hanson
2004/0035358	A1	2/2004	Basceri et al.	2004/0247779	A1	12/2004	Selvamanickam et al.
2004/0036129	A1	2/2004	Forbes et al.	2004/0250600	A1	12/2004	Bevers et al.
2004/0037675	A1	2/2004	Zinger et al.	2004/0253867	A1	12/2004	Matsumoto
2004/0043544	A1	3/2004	Asai et al.	2004/0261492	A1	12/2004	Zarkar et al.
2004/0048439	A1	3/2004	Soman	2004/0261712	A1	12/2004	Hayashi et al.
2004/0048452	A1	3/2004	Sugawara et al.	2004/0266011	A1	12/2004	Lee et al.
2004/0048492	A1	3/2004	Ishikawa et al.	2005/0000428	A1	1/2005	Shero et al.
2004/0050325	A1	3/2004	Samoilov	2005/0003662	A1	1/2005	Jurisch et al.
2004/0056017	A1	3/2004	Renken	2005/0008799	A1	1/2005	Tomiyasu et al.
2004/0062081	A1	4/2004	Drewes	2005/0009325	A1	1/2005	Chung et al.
2004/0063289	A1	4/2004	Ohta	2005/0017272	A1	1/2005	Yamashita et al.
2004/0065255	A1	4/2004	Yang et al.	2005/0019026	A1	1/2005	Wang et al.
2004/0069226	A1	4/2004	Yoshida et al.	2005/0019494	A1	1/2005	Moghadam et al.
2004/0071897	A1	4/2004	Verplancken et al.	2005/0020071	A1	1/2005	Sonobe et al.
2004/0077182	A1	4/2004	Lim et al.	2005/0023624	A1	2/2005	Ahn et al.
2004/0079960	A1	4/2004	Shakuda	2005/0026402	A1	2/2005	Jurgensen
2004/0080697	A1	4/2004	Song	2005/0033075	A1	2/2005	Chi et al.
2004/0082171	A1	4/2004	Shin et al.	2005/0034664	A1	2/2005	Koh et al.
2004/0083964	A1	5/2004	Ingle et al.	2005/0034674	A1	2/2005	Ono
2004/0083975	A1	5/2004	Tong et al.	2005/0037154	A1	2/2005	Koh et al.
2004/0087141	A1	5/2004	Ramanathan et al.	2005/0037578	A1	2/2005	Chen et al.
2004/0089236	A1	5/2004	Yokogawa et al.	2005/0037610	A1	2/2005	Cha
2004/0092073	A1	5/2004	Cabral et al.	2005/0042778	A1	2/2005	Peukert
2004/0092120	A1	5/2004	Wicker	2005/0046825	A1	3/2005	Powell et al.
2004/0094206	A1	5/2004	Ishida	2005/0048797	A1	3/2005	Fukazawa
2004/0094402	A1	5/2004	Gopalraja	2005/0051093	A1	3/2005	Makino et al.
2004/0099213	A1	5/2004	Adomaitis et al.	2005/0054228	A1	3/2005	March
2004/0101622	A1	5/2004	Park et al.	2005/0056218	A1	3/2005	Sun et al.
2004/0103914	A1	6/2004	Cheng et al.	2005/0056780	A1	3/2005	Miller et al.
2004/0105738	A1	6/2004	Ahn et al.	2005/0059261	A1	3/2005	Basceri et al.
2004/0106249	A1	6/2004	Huotari	2005/0059262	A1	3/2005	Yin et al.
2004/0115936	A1	6/2004	DePetrillo et al.	2005/0059264	A1	3/2005	Cheung
2004/0124131	A1	7/2004	Aitchison	2005/0061964	A1	3/2005	Nagano et al.
2004/0124549	A1	7/2004	Curran	2005/0064207	A1	3/2005	Senzaki et al.
2004/0126990	A1	7/2004	Ohta	2005/0064719	A1	3/2005	Liu
2004/0127069	A1	7/2004	Yamazaki et al.	2005/0066893	A1	3/2005	Soininen
2004/0129211	A1	7/2004	Blonigan et al.	2005/0069651	A1	3/2005	Miyoshi
2004/0129671	A1	7/2004	Ji et al.	2005/0070123	A1	3/2005	Hirano
2004/0134429	A1	7/2004	Yamanaka	2005/0070729	A1	3/2005	Kiyomori et al.
				2005/0072357	A1	4/2005	Shero et al.
				2005/0074983	A1	4/2005	Shinriki et al.
				2005/0092247	A1	5/2005	Schmidt
				2005/0092249	A1	5/2005	Kilpela et al.

(56)

References Cited

U.S. PATENT DOCUMENTS

2005/0092733	A1	5/2005	Ito et al.	2005/0274323	A1	12/2005	Seidel et al.
2005/0095770	A1	5/2005	Kumagai et al.	2005/0277271	A1	12/2005	Beintner
2005/0095859	A1	5/2005	Chen et al.	2005/0282101	A1	12/2005	Adachi
2005/0098107	A1	5/2005	Du Bois et al.	2005/0284991	A1	12/2005	Saez
2005/0100669	A1	5/2005	Kools et al.	2005/0285097	A1	12/2005	Shang et al.
2005/0101154	A1	5/2005	Huang	2005/0287725	A1	12/2005	Kitagawa
2005/0101843	A1	5/2005	Quinn et al.	2005/0287771	A1	12/2005	Seamons et al.
2005/0106893	A1	5/2005	Wilk	2006/0000411	A1	1/2006	Seo
2005/0107627	A1	5/2005	Dussarrat et al.	2006/0009044	A1	1/2006	Igeta
2005/0109461	A1	5/2005	Sun	2006/0013674	A1	1/2006	Elliott et al.
2005/0110069	A1	5/2005	Kil et al.	2006/0013946	A1	1/2006	Park et al.
2005/0115946	A1	6/2005	Shim et al.	2006/0014384	A1	1/2006	Lee et al.
2005/0118804	A1	6/2005	Byun et al.	2006/0014397	A1	1/2006	Seamons et al.
2005/0118837	A1	6/2005	Todd	2006/0016783	A1	1/2006	Wu et al.
2005/0120805	A1	6/2005	Lane	2006/0019033	A1	1/2006	Muthukrishnan et al.
2005/0120962	A1	6/2005	Ushioda et al.	2006/0019502	A1	1/2006	Park et al.
2005/0123690	A1	6/2005	Derderian et al.	2006/0021572	A1	2/2006	Wolden
2005/0130427	A1	6/2005	Seok-Jun	2006/0021573	A1	2/2006	Monsma et al.
2005/0132957	A1	6/2005	El-Raghy	2006/0021703	A1	2/2006	Umotoy et al.
2005/0133161	A1	6/2005	Carpenter et al.	2006/0024439	A2	2/2006	Tuominen et al.
2005/0141591	A1	6/2005	Sakano	2006/0026314	A1	2/2006	Franchuk et al.
2005/0142361	A1	6/2005	Nakanishi	2006/0040054	A1	2/2006	Pearlstein et al.
2005/0145338	A1	7/2005	Park et al.	2006/0040508	A1	2/2006	Ji
2005/0148162	A1	7/2005	Chen et al.	2006/0046518	A1	3/2006	Hill et al.
2005/0153571	A1	7/2005	Senzaki	2006/0048710	A1	3/2006	Horiguchi et al.
2005/0161434	A1	7/2005	Sugawara et al.	2006/0051520	A1	3/2006	Behle et al.
2005/0172895	A1	8/2005	Kijima et al.	2006/0051925	A1	3/2006	Ahn et al.
2005/0173003	A1	8/2005	Laverdiere et al.	2006/0057799	A1	3/2006	Horiguchi et al.
2005/0175789	A1	8/2005	Helms	2006/0057828	A1	3/2006	Omura
2005/0181535	A1	8/2005	Yun et al.	2006/0060930	A1	3/2006	Metz et al.
2005/0181555	A1	8/2005	Haukka et al.	2006/0062910	A1	3/2006	Meiere
2005/0183827	A1	8/2005	White et al.	2006/0063346	A1	3/2006	Lee et al.
2005/0186688	A1	8/2005	Basceri	2006/0068104	A1	3/2006	Ishizaka
2005/0187647	A1	8/2005	Wang et al.	2006/0068121	A1	3/2006	Lee et al.
2005/0191828	A1	9/2005	Al-Bayati et al.	2006/0068125	A1	3/2006	Radhakrishnan
2005/0193948	A1	9/2005	Oohirabaru et al.	2006/0087638	A1	4/2006	Hirayanagi
2005/0199013	A1	9/2005	Vandroux et al.	2006/0096540	A1	5/2006	Choi
2005/0208217	A1	9/2005	Shinriki et al.	2006/0099782	A1	5/2006	Ritenour
2005/0208219	A1	9/2005	Basceri	2006/0105566	A1	5/2006	Waldfried et al.
2005/0208718	A1	9/2005	Lim et al.	2006/0107898	A1	5/2006	Blomberg
2005/0211167	A1	9/2005	Gunji	2006/0108221	A1	5/2006	Goodwin et al.
2005/0212119	A1	9/2005	Shero	2006/0110934	A1	5/2006	Fukuchi
2005/0214457	A1	9/2005	Schmitt et al.	2006/0113038	A1	6/2006	Gondhalekar et al.
2005/0214458	A1	9/2005	Meiere	2006/0113675	A1	6/2006	Chang et al.
2005/0208778	A1	10/2005	Li	2006/0113806	A1	6/2006	Tsuji et al.
2005/0218462	A1	10/2005	Ahn et al.	2006/0127067	A1	6/2006	Wintenberger et al.
2005/0221021	A1	10/2005	Strang	2006/0128142	A1	6/2006	Whelan et al.
2005/0221618	A1	10/2005	AmRhein et al.	2006/0128168	A1	6/2006	Ahn et al.
2005/0223982	A1	10/2005	Park et al.	2006/0130767	A1	6/2006	Herchen
2005/0223994	A1	10/2005	Blomiley et al.	2006/0137608	A1	6/2006	Choi et al.
2005/0227502	A1	10/2005	Schmitt et al.	2006/0137609	A1	6/2006	Puchacz et al.
2005/0229848	A1	10/2005	Shinriki	2006/0141155	A1	6/2006	Gordon et al.
2005/0229849	A1	10/2005	Silvetti et al.	2006/0147626	A1	7/2006	Blomberg
2005/0229972	A1	10/2005	Hoshi et al.	2006/0148180	A1	7/2006	Ahn et al.
2005/0233477	A1	10/2005	Yamazaki et al.	2006/0151117	A1	7/2006	Kasanami et al.
2005/0241176	A1	11/2005	Shero et al.	2006/0154424	A1	7/2006	Yang et al.
2005/0241763	A1	11/2005	Huang et al.	2006/0156981	A1	7/2006	Fondurulia
2005/0245058	A1	11/2005	Lee et al.	2006/0163612	A1	7/2006	Kouvetakis et al.
2005/0249876	A1	11/2005	Kawahara et al.	2006/0165892	A1	7/2006	Weidman
2005/0250340	A1	11/2005	Chen et al.	2006/0166428	A1	7/2006	Kamioka et al.
2005/0251990	A1	11/2005	Choi	2006/0172531	A1	8/2006	Lin et al.
2005/0252447	A1	11/2005	Zhao et al.	2006/0175669	A1	8/2006	Kim et al.
2005/0252449	A1	11/2005	Nguyen et al.	2006/0177855	A1	8/2006	Utermohlen
2005/0252455	A1	11/2005	Moriya et al.	2006/0182885	A1	8/2006	Lei et al.
2005/0253061	A1	11/2005	Cameron et al.	2006/0188360	A1	8/2006	Bonora et al.
2005/0255257	A1	11/2005	Choi et al.	2006/0191555	A1	8/2006	Yoshida et al.
2005/0258280	A1	11/2005	Goto et al.	2006/0193979	A1	8/2006	Meiere et al.
2005/0260347	A1	11/2005	Narwankar et al.	2006/0196420	A1	9/2006	Ushakov et al.
2005/0260837	A1	11/2005	Walther et al.	2006/0199357	A1	9/2006	Wan et al.
2005/0260850	A1	11/2005	Loke	2006/0205194	A1	9/2006	Bauer
2005/0263072	A1	12/2005	Balasubramanian et al.	2006/0205223	A1	9/2006	Smayling
2005/0263075	A1	12/2005	Wang et al.	2006/0205231	A1	9/2006	Chou et al.
2005/0263932	A1	12/2005	Heugel	2006/0208215	A1	9/2006	Metzner et al.
2005/0271812	A1	12/2005	Myo et al.	2006/0211243	A1	9/2006	Ishizaka et al.
2005/0271813	A1	12/2005	Kher et al.	2006/0211259	A1	9/2006	Maes
				2006/0213439	A1	9/2006	Ishizaka
				2006/0216942	A1	9/2006	Kim et al.
				2006/0219169	A1	10/2006	Chen et al.
				2006/0223301	A1	10/2006	Vanhaelemeersch et al.

(56)

References Cited

U.S. PATENT DOCUMENTS

2006/0226117	A1	10/2006	Bertram et al.	2007/0095286	A1	5/2007	Baek et al.
2006/0228496	A1	10/2006	Choi	2007/0096194	A1	5/2007	Streck et al.
2006/0228863	A1	10/2006	Zhang et al.	2007/0098527	A1	5/2007	Hall et al.
2006/0228888	A1	10/2006	Lee et al.	2007/0107845	A1	5/2007	Ishizawa et al.
2006/0228898	A1	10/2006	Wajda et al.	2007/0111470	A1	5/2007	Smythe
2006/0236934	A1	10/2006	Choi et al.	2007/0111545	A1	5/2007	Lee et al.
2006/0240187	A1	10/2006	Weidman	2007/0116873	A1	5/2007	Li et al.
2006/0240574	A1	10/2006	Yoshie	2007/0116888	A1	5/2007	Faguet
2006/0240662	A1	10/2006	Conley et al.	2007/0119370	A1	5/2007	Ma et al.
2006/0249253	A1	11/2006	Dando	2007/0123037	A1	5/2007	Lee et al.
2006/0251827	A1	11/2006	Nowak	2007/0123189	A1	5/2007	Saito et al.
2006/0252228	A1	11/2006	Jeng	2007/0125762	A1	6/2007	Cui et al.
2006/0252351	A1	11/2006	Kundracik	2007/0128538	A1	6/2007	Fairbairn et al.
2006/0257563	A1	11/2006	Doh et al.	2007/0128858	A1	6/2007	Haukka et al.
2006/0257584	A1	11/2006	Derderian et al.	2007/0128876	A1	6/2007	Fukiage
2006/0258078	A1	11/2006	Lee et al.	2007/0128888	A1	6/2007	Goto et al.
2006/0258173	A1	11/2006	Xiao et al.	2007/0129621	A1	6/2007	Kellogg et al.
2006/0260545	A1	11/2006	Ramaswamy et al.	2007/0131168	A1	6/2007	Gomi et al.
2006/0263522	A1	11/2006	Byun	2007/0134919	A1	6/2007	Gunji et al.
2006/0264060	A1	11/2006	Ramaswamy et al.	2007/0134942	A1	6/2007	Ahn et al.
2006/0264066	A1	11/2006	Bartholomew	2007/0137794	A1	6/2007	Qiu et al.
2006/0266289	A1	11/2006	Vergheze et al.	2007/0146621	A1	6/2007	Yeom
2006/0269690	A1	11/2006	Watanabe et al.	2007/0148347	A1	6/2007	Hatanpaa et al.
2006/0269692	A1	11/2006	Balseanu	2007/0148350	A1	6/2007	Rahtu
2006/0275710	A1	12/2006	Yamazaki et al.	2007/0148990	A1	6/2007	Deboer et al.
2006/0275933	A1	12/2006	Du Bois et al.	2007/0155138	A1	7/2007	Tomasini et al.
2006/0278524	A1	12/2006	Stowell	2007/0157466	A1	7/2007	Kida et al.
2006/0283629	A1	12/2006	Kikuchi et al.	2007/0158026	A1	7/2007	Amikura
2006/0286774	A1	12/2006	Singh et al.	2007/0163440	A1	7/2007	Kim et al.
2006/0286775	A1	12/2006	Singh et al.	2007/0163625	A1	7/2007	Lee
2006/0286817	A1	12/2006	Kato et al.	2007/0166457	A1	7/2007	Yamoto et al.
2006/0286818	A1	12/2006	Wang et al.	2007/0166966	A1	7/2007	Todd et al.
2006/0286819	A1	12/2006	Seutter	2007/0166999	A1	7/2007	Vaarstra
2006/0291982	A1	12/2006	Tanaka	2007/0170372	A1	7/2007	Horsky
2007/0006806	A1	1/2007	Imai	2007/0173071	A1	7/2007	Afzali-Ardakani et al.
2007/0010072	A1	1/2007	Bailey et al.	2007/0175393	A1	8/2007	Nishimura et al.
2007/0012402	A1	1/2007	Sneh	2007/0175397	A1	8/2007	Tomiyasu et al.
2007/0020160	A1	1/2007	Berkman et al.	2007/0178235	A1	8/2007	Yamada et al.
2007/0020167	A1	1/2007	Han et al.	2007/0184179	A1	8/2007	Waghray et al.
2007/0020830	A1	1/2007	Speranza	2007/0186849	A1	8/2007	Furuya
2007/0020953	A1	1/2007	Tsai et al.	2007/0186952	A1	8/2007	Honda et al.
2007/0022954	A1	2/2007	Iizuka et al.	2007/0187363	A1	8/2007	Oka et al.
2007/0026148	A1	2/2007	Arai et al.	2007/0190362	A1	8/2007	Weidman
2007/0026162	A1	2/2007	Wei et al.	2007/0190782	A1	8/2007	Park
2007/0028842	A1	2/2007	Inagawa et al.	2007/0202678	A1	8/2007	Plombon et al.
2007/0031598	A1	2/2007	Okuyama et al.	2007/0207275	A1	9/2007	Nowak et al.
2007/0031599	A1	2/2007	Gschwandtner et al.	2007/0209590	A1	9/2007	Li
2007/0032045	A1	2/2007	Kasahara et al.	2007/0210890	A1	9/2007	Hsu et al.
2007/0032082	A1	2/2007	Ramaswamy et al.	2007/0215048	A1	9/2007	Suzuki et al.
2007/0034477	A1	2/2007	Inui	2007/0218200	A1	9/2007	Suzuki et al.
2007/0037343	A1	2/2007	Colombo et al.	2007/0218705	A1	9/2007	Matsuki et al.
2007/0037412	A1	2/2007	Dip et al.	2007/0224777	A1	9/2007	Hamelin
2007/0042117	A1	2/2007	Kupurao et al.	2007/0224833	A1	9/2007	Morisada et al.
2007/0049053	A1	3/2007	Mahajani	2007/0231488	A1	10/2007	Von Kaenel
2007/0051299	A1	3/2007	Ong et al.	2007/0232031	A1	10/2007	Singh et al.
2007/0054499	A1	3/2007	Jang	2007/0232071	A1	10/2007	Balseanu et al.
2007/0056843	A1	3/2007	Ye et al.	2007/0232501	A1	10/2007	Tomomura
2007/0056850	A1	3/2007	Ye et al.	2007/0234955	A1	10/2007	Suzuki et al.
2007/0059948	A1	3/2007	Metzner et al.	2007/0237697	A1	10/2007	Clark
2007/0062439	A1	3/2007	Wada et al.	2007/0237698	A1	10/2007	Clark
2007/0062453	A1	3/2007	Ishikawa	2007/0237699	A1	10/2007	Clark
2007/0062646	A1	3/2007	Ogawa et al.	2007/0241688	A1	10/2007	DeVancentis et al.
2007/0065578	A1	3/2007	McDougall	2007/0248767	A1	10/2007	Okura
2007/0066010	A1	3/2007	Ando	2007/0249131	A1	10/2007	Allen et al.
2007/0066038	A1	3/2007	Sadjadi et al.	2007/0252532	A1	10/2007	DeVancentis et al.
2007/0066079	A1	3/2007	Kolster et al.	2007/0251444	A1	11/2007	Gros-Jean et al.
2007/0066084	A1	3/2007	Wajda et al.	2007/0251456	A1	11/2007	Herchen et al.
2007/0077355	A1	4/2007	Chacin et al.	2007/0252233	A1	11/2007	Yamazaki et al.
2007/0082132	A1	4/2007	Shinriki	2007/0252244	A1	11/2007	Srividya et al.
2007/0082500	A1	4/2007	Norman et al.	2007/0258506	A1	11/2007	Schwagerman et al.
2007/0084405	A1	4/2007	Kim	2007/0258855	A1	11/2007	Turcot et al.
2007/0087296	A1	4/2007	Kim et al.	2007/0261868	A1	11/2007	Gross
2007/0087579	A1	4/2007	Kitayama et al.	2007/0264807	A1	11/2007	Leone et al.
2007/0089670	A1	4/2007	Ikedo	2007/0266945	A1	11/2007	Shuto et al.
2007/0095283	A1	5/2007	Galewski	2007/0269983	A1	11/2007	Sneh
				2007/0275166	A1	11/2007	Thridandam et al.
				2007/0277735	A1	12/2007	Mokhesi et al.
				2007/0281082	A1	12/2007	Mokhesi et al.
				2007/0281105	A1	12/2007	Mokhesi et al.

(56)

References Cited

U.S. PATENT DOCUMENTS

2007/0281496 A1	12/2007	Ingle et al.	2008/0179104 A1	7/2008	Zhang
2007/0292974 A1	12/2007	Mizuno et al.	2008/0179715 A1	7/2008	Coppa
2007/0295602 A1	12/2007	Tiller et al.	2008/0182075 A1	7/2008	Chopra
2007/0298362 A1	12/2007	Rocha-Alvarez et al.	2008/0182390 A1	7/2008	Lemmi et al.
2008/0003824 A1	1/2008	Padhi et al.	2008/0182411 A1	7/2008	Elers
2008/0003838 A1	1/2008	Haukka et al.	2008/0191193 A1	8/2008	Li et al.
2008/0006208 A1	1/2008	Ueno et al.	2008/0193643 A1	8/2008	Dip
2008/0018004 A1	1/2008	Steidl	2008/0194105 A1	8/2008	Dominguez et al.
2008/0020591 A1	1/2008	Balseanu et al.	2008/0199977 A1	8/2008	Weigel et al.
2008/0020593 A1	1/2008	Wang et al.	2008/0202416 A1	8/2008	Provencher
2008/0023436 A1	1/2008	Gros-Jean et al.	2008/0202689 A1	8/2008	Kim
2008/0026162 A1	1/2008	Dickey et al.	2008/0203487 A1	8/2008	Hohage et al.
2008/0026574 A1	1/2008	Brcka	2008/0205483 A1	8/2008	Rempe et al.
2008/0026597 A1	1/2008	Munro et al.	2008/0210278 A1	9/2008	Orii et al.
2008/0029790 A1	2/2008	Ahn et al.	2008/0211423 A1	9/2008	Shinmen et al.
2008/0031708 A1	2/2008	Bonora et al.	2008/0211526 A1	9/2008	Shinma
2008/0036354 A1	2/2008	Letz et al.	2008/0214003 A1	9/2008	Xia et al.
2008/0038485 A1	2/2008	Fuzakawa et al.	2008/0216077 A1	9/2008	Emani et al.
2008/0038934 A1	2/2008	Vrtis et al.	2008/0216742 A1	9/2008	Takebayashi
2008/0042165 A1	2/2008	Sugizaki	2008/0220619 A1	9/2008	Matsushita et al.
2008/0043803 A1	2/2008	Bandoh	2008/0223130 A1	9/2008	Snell et al.
2008/0044938 A1	2/2008	England et al.	2008/0224240 A1	9/2008	Ahn et al.
2008/0050536 A1	2/2008	Aing et al.	2008/0228306 A1	9/2008	Yetter et al.
2008/0050538 A1	2/2008	Hirata	2008/0233288 A1	9/2008	Clark
2008/0054332 A1	3/2008	Kim et al.	2008/0237572 A1	10/2008	Chui et al.
2008/0054813 A1	3/2008	Espiau et al.	2008/0241052 A1	10/2008	Hooper et al.
2008/0056860 A1	3/2008	Natume	2008/0241384 A1	10/2008	Jeong
2008/0057659 A1	3/2008	Forbes et al.	2008/0241387 A1	10/2008	Keto
2008/0061667 A1	3/2008	Gaertner et al.	2008/0242116 A1	10/2008	Clark
2008/0063798 A1	3/2008	Kher et al.	2008/0242116 A1	10/2008	Clark
2008/0066778 A1	3/2008	Matsushita et al.	2008/0248310 A1	10/2008	Kim et al.
2008/0067146 A1	3/2008	Onishi et al.	2008/0248597 A1	10/2008	Qin et al.
2008/0069955 A1	3/2008	Hong et al.	2008/0257102 A1*	10/2008	Packer B62K 21/26 74/551.9
2008/0075562 A1	3/2008	Maria et al.	2008/0257494 A1	10/2008	Hayashi et al.
2008/0075881 A1	3/2008	Won et al.	2008/0260963 A1	10/2008	Yoon et al.
2008/0076070 A1	3/2008	Koh et al.	2008/0261413 A1	10/2008	Mahajani
2008/0076266 A1	3/2008	Fukazawa et al.	2008/0264337 A1	10/2008	Sano et al.
2008/0081104 A1	4/2008	Hasebe et al.	2008/0267598 A1	10/2008	Nakamura
2008/0081113 A1	4/2008	Clark	2008/0268171 A1	10/2008	Ma et al.
2008/0081121 A1	4/2008	Morita et al.	2008/0268635 A1	10/2008	Yu et al.
2008/0085226 A1	4/2008	Fondurulia et al.	2008/0272424 A1	11/2008	Kim et al.
2008/0092815 A1	4/2008	Chen et al.	2008/0274369 A1	11/2008	Lee et al.
2008/0102203 A1	5/2008	Wu	2008/0277647 A1	11/2008	Kouvetakis et al.
2008/0102205 A1	5/2008	Barry et al.	2008/0277715 A1	11/2008	Ohmi et al.
2008/0102208 A1	5/2008	Wu et al.	2008/0282970 A1	11/2008	Heys et al.
2008/0113094 A1	5/2008	Casper	2008/0283962 A1	11/2008	Dyer
2008/0113096 A1	5/2008	Mahajani	2008/0289574 A1	11/2008	Jacobs et al.
2008/0113097 A1	5/2008	Mahajani et al.	2008/0291964 A1	11/2008	Shrimpling
2008/0118334 A1	5/2008	Bonora	2008/0295872 A1	12/2008	Riker et al.
2008/0121177 A1	5/2008	Bang et al.	2008/0298945 A1	12/2008	Cox
2008/0121626 A1	5/2008	Thomas et al.	2008/0299326 A1	12/2008	Fukazawa
2008/0124197 A1	5/2008	van der Meulen et al.	2008/0299758 A1	12/2008	Harada et al.
2008/0124908 A1	5/2008	Forbes et al.	2008/0302303 A1	12/2008	Choi et al.
2008/0124945 A1	5/2008	Miya et al.	2008/0305014 A1	12/2008	Honda
2008/0124946 A1	5/2008	Xiao et al.	2008/0305246 A1	12/2008	Choi et al.
2008/0128726 A1	6/2008	Sakata et al.	2008/0305443 A1	12/2008	Nakamura
2008/0129209 A1	6/2008	Deakins et al.	2008/0314892 A1	12/2008	Graham
2008/0132046 A1	6/2008	Walther	2008/0315292 A1	12/2008	Ji et al.
2008/0133154 A1	6/2008	Krauss et al.	2008/0317972 A1	12/2008	Hendriks
2008/0142483 A1	6/2008	Hua	2009/0000550 A1	1/2009	Tran et al.
2008/0149031 A1	6/2008	Chu et al.	2009/0000551 A1	1/2009	Choi et al.
2008/0149593 A1	6/2008	Bai et al.	2009/0000769 A1	1/2009	Lin et al.
2008/0152463 A1	6/2008	Chidambaram et al.	2009/0004875 A1	1/2009	Shen et al.
2008/0153308 A1	6/2008	Ogawa et al.	2009/0011145 A1	1/2009	Yun
2008/0153311 A1	6/2008	Padhi et al.	2009/0011608 A1	1/2009	Nabatame
2008/0157157 A1	7/2008	Tomomura	2009/0017631 A1	1/2009	Bencher
2008/0157365 A1	7/2008	Ott et al.	2009/0020072 A1	1/2009	Mizunaga et al.
2008/0173237 A1	7/2008	Collins	2009/0023229 A1	1/2009	Matsushita
2008/0173238 A1	7/2008	Nakashima et al.	2009/0029503 A1	1/2009	Arai
2008/0173240 A1	7/2008	Furukawahara	2009/0029528 A1	1/2009	Sanchez et al.
2008/0173326 A1	7/2008	Gu et al.	2009/0029564 A1	1/2009	Yamashita et al.
2008/0176335 A1	7/2008	Alberti et al.	2009/0033907 A1	2/2009	Watson
2008/0176375 A1	7/2008	Erben et al.	2009/0035927 A1	2/2009	Olsen et al.
2008/0176412 A1	7/2008	Komeda	2009/0035947 A1	2/2009	Horii
2008/0178805 A1	7/2008	Paterson et al.	2009/0041952 A1	2/2009	Yoon et al.
			2009/0041984 A1	2/2009	Mayers et al.
			2009/0042344 A1	2/2009	Ye et al.
			2009/0042408 A1	2/2009	Maeda
			2009/0045829 A1	2/2009	Awazu

(56)

References Cited

U.S. PATENT DOCUMENTS

2009/0047433	A1	2/2009	Kim et al.	2009/0250004	A1	10/2009	Yamada et al.
2009/0050621	A1	2/2009	Awazu	2009/0250955	A1	10/2009	Aoki
2009/0052498	A1	2/2009	Halpin et al.	2009/0255901	A1	10/2009	Okita
2009/0053023	A1	2/2009	Wakabayashi	2009/0261331	A1	10/2009	Yang et al.
2009/0053900	A1	2/2009	Nozawa et al.	2009/0267225	A1	10/2009	Eguchi
2009/0053906	A1	2/2009	Miya et al.	2009/0269506	A1	10/2009	Okura et al.
2009/0056112	A1	3/2009	Kobayashi	2009/0269507	A1	10/2009	Yu et al.
2009/0056629	A1	3/2009	Katz et al.	2009/0269941	A1	10/2009	Raisanen
2009/0057269	A1	3/2009	Katz et al.	2009/0275205	A1	11/2009	Kiehlbauch et al.
2009/0061083	A1	3/2009	Chiang et al.	2009/0275210	A1	11/2009	Shanker et al.
2009/0061644	A1	3/2009	Chiang et al.	2009/0277510	A1	11/2009	Shikata
2009/0061647	A1	3/2009	Mallick et al.	2009/0280248	A1	11/2009	Goodman et al.
2009/0075491	A1	3/2009	Liu et al.	2009/0283041	A1	11/2009	Tomiyasu et al.
2009/0084317	A1	4/2009	Wu	2009/0283217	A1	11/2009	Lubomirsky et al.
2009/0085156	A1	4/2009	Dewey et al.	2009/0284156	A1	11/2009	Banna et al.
2009/0087585	A1	4/2009	Lee et al.	2009/0286400	A1	11/2009	Heo et al.
2009/0090382	A1	4/2009	Morisada	2009/0286402	A1	11/2009	Xia et al.
2009/0093094	A1	4/2009	Ye et al.	2009/0289300	A1	11/2009	Sasaki et al.
2009/0095221	A1	4/2009	Tam et al.	2009/0297710	A1	12/2009	Lindfors
2009/0104351	A1	4/2009	Takegawa	2009/0298257	A1	12/2009	Lee et al.
2009/0104594	A1	4/2009	Webb	2009/0302434	A1	12/2009	Pallem et al.
2009/0104789	A1	4/2009	Mallick et al.	2009/0304558	A1	12/2009	Patton
2009/0107404	A1	4/2009	Ogliari et al.	2009/0308315	A1	12/2009	de Ridder
2009/0108308	A1	4/2009	Yang et al.	2009/0308425	A1	12/2009	Yednak
2009/0112458	A1	4/2009	Nakai	2009/0311857	A1	12/2009	Todd et al.
2009/0115064	A1	5/2009	Sandhu et al.	2009/0315093	A1	12/2009	Li et al.
2009/0116936	A1	5/2009	Marubayashi et al.	2009/0320754	A1	12/2009	Oya
2009/0117717	A1	5/2009	Tomasini et al.	2009/0324971	A1	12/2009	De Vries et al.
2009/0120580	A1	5/2009	Kagoshima et al.	2009/0324989	A1	12/2009	Witz et al.
2009/0122293	A1	5/2009	Shibazaki	2009/0325391	A1	12/2009	De Vusser et al.
2009/0122458	A1	5/2009	Lischer et al.	2009/0325469	A1	12/2009	Koo et al.
2009/0124131	A1	5/2009	Breunsbach et al.	2010/0000608	A1	1/2010	Goto et al.
2009/0130331	A1	5/2009	Asai	2010/0001409	A1	1/2010	Humbert et al.
2009/0130859	A1	5/2009	Itatani et al.	2010/0003406	A1	1/2010	Lam et al.
2009/0136668	A1	5/2009	Gregg et al.	2010/0006031	A1	1/2010	Choi et al.
2009/0136683	A1	5/2009	Fukasawa et al.	2010/0006923	A1	1/2010	Fujitsuka
2009/0137055	A1	5/2009	Bognar	2010/0014479	A1	1/2010	Kim
2009/0139657	A1	6/2009	Lee et al.	2010/0015813	A1	1/2010	McGinnis et al.
2009/0142905	A1	6/2009	Yamazaki	2010/0018460	A1	1/2010	Singh et al.
2009/0142935	A1	6/2009	Fukazawa et al.	2010/0024727	A1	2/2010	Kim et al.
2009/0146322	A1	6/2009	Weling et al.	2010/0024872	A1	2/2010	Kishimoto
2009/0147819	A1	6/2009	Goodman et al.	2010/0025766	A1	2/2010	Nuttinck et al.
2009/0155488	A1	6/2009	Nakano et al.	2010/0025796	A1	2/2010	Dabiran
2009/0156015	A1	6/2009	Park et al.	2010/0032587	A1	2/2010	Hosch et al.
2009/0159000	A1	6/2009	Aggarwal et al.	2010/0032842	A1	2/2010	Herdt et al.
2009/0159002	A1	6/2009	Bera et al.	2010/0034719	A1	2/2010	Dussarrat et al.
2009/0159424	A1	6/2009	Liu et al.	2010/0040441	A1	2/2010	Obikane
2009/0162996	A1	6/2009	Ramaswamy et al.	2010/0041179	A1	2/2010	Lee
2009/0163038	A1	6/2009	Miyoshi	2010/0041243	A1	2/2010	Cheng et al.
2009/0165715	A1	7/2009	Oh	2010/0050943	A1	3/2010	Kato et al.
2009/0165721	A1	7/2009	Pitney et al.	2010/0051584	A1	3/2010	Okita et al.
2009/0165722	A1	7/2009	Ha	2010/0051597	A1	3/2010	Morita et al.
2009/0166616	A1	7/2009	Uchiyama	2010/0055312	A1	3/2010	Kato et al.
2009/0179365	A1	7/2009	Lerner et al.	2010/0055316	A1	3/2010	Honma
2009/0186571	A1	7/2009	Haro	2010/0055442	A1	3/2010	Kellock
2009/0197015	A1	8/2009	Kudela et al.	2010/0055898	A1	3/2010	Chang et al.
2009/0197411	A1	8/2009	Dussarrat et al.	2010/0058984	A1	3/2010	Marubayashi
2009/0200494	A1	8/2009	Hatem	2010/0065758	A1	3/2010	Liu et al.
2009/0200547	A1	8/2009	Griffin et al.	2010/0068009	A1	3/2010	Kimura
2009/0204403	A1	8/2009	Hollander et al.	2010/0068891	A1	3/2010	Hatanaka et al.
2009/0206056	A1	8/2009	Xu	2010/0075037	A1	3/2010	Marsh et al.
2009/0209081	A1	8/2009	Matero	2010/0075507	A1	3/2010	Chang et al.
2009/0211523	A1	8/2009	Kuppurao et al.	2010/0081094	A1	4/2010	Hasebe et al.
2009/0211525	A1	8/2009	Sarigiannis et al.	2010/0086703	A1	4/2010	Mangum et al.
2009/0223441	A1	9/2009	Arena et al.	2010/0089320	A1	4/2010	Kim
2009/0227094	A1	9/2009	Bateman	2010/0089870	A1	4/2010	Hiroshima et al.
2009/0230211	A1	9/2009	Kobayashi et al.	2010/0090149	A1	4/2010	Thompson et al.
2009/0232985	A1	9/2009	Dussarrat et al.	2010/0092696	A1	4/2010	Shinriki
2009/0236014	A1	9/2009	Wilson	2010/0093187	A1	4/2010	Lee et al.
2009/0236276	A1	9/2009	Kurth et al.	2010/0098862	A1	4/2010	Xu et al.
2009/0239386	A1	9/2009	Suzaki et al.	2010/0102417	A1	4/2010	Ganguli et al.
2009/0242957	A1	10/2009	Ma et al.	2010/0105936	A1	4/2010	Tada et al.
2009/0246374	A1	10/2009	Vukovic	2010/0111648	A1	5/2010	Tamura et al.
2009/0246399	A1	10/2009	Goundar	2010/0112496	A1	5/2010	Nakajima et al.
2009/0246971	A1	10/2009	Reid et al.	2010/0116207	A1	5/2010	Givens
				2010/0116209	A1	5/2010	Kato
				2010/0119439	A1	5/2010	Shindou
				2010/0124610	A1	5/2010	Aikawa et al.
				2010/0124618	A1	5/2010	Kobayashi et al.

(56)

References Cited

U.S. PATENT DOCUMENTS

2010/0124621	A1	5/2010	Kobayashi et al.	2011/0000619	A1	1/2011	Suh
2010/0126415	A1	5/2010	Ishino et al.	2011/0006402	A1	1/2011	Zhou
2010/0126539	A1	5/2010	Lee et al.	2011/0006406	A1	1/2011	Urbanowicz et al.
2010/0126605	A1	5/2010	Stones	2011/0014359	A1	1/2011	Hashim
2010/0129548	A1	5/2010	Sneh	2011/0014795	A1	1/2011	Lee
2010/0129990	A1	5/2010	Nishizawa et al.	2011/0021033	A1	1/2011	Ikeuchi et al.
2010/0130015	A1	5/2010	Nakajima et al.	2011/0027725	A1	2/2011	Tsutsumi et al.
2010/0130017	A1	5/2010	Luo et al.	2011/0027999	A1	2/2011	Sparks et al.
2010/0130105	A1	5/2010	Lee	2011/0031562	A1	2/2011	Lin et al.
2010/0134023	A1	6/2010	Mills	2011/0034039	A1	2/2011	Liang et al.
2010/0136216	A1	6/2010	Tsuei et al.	2011/0042200	A1	2/2011	Wilby
2010/0140221	A1	6/2010	Kikuchi et al.	2011/0045610	A1	2/2011	van Schravendijk
2010/0140684	A1	6/2010	Ozawa	2011/0046314	A1	2/2011	Klipp et al.
2010/0143609	A1	6/2010	Fukazawa et al.	2011/0048642	A1	3/2011	Mihara et al.
2010/0144162	A1	6/2010	Lee et al.	2011/0048769	A1	3/2011	Fujwara
2010/0144968	A1	6/2010	Lee et al.	2011/0049100	A1	3/2011	Han et al.
2010/0145547	A1	6/2010	Darabnia et al.	2011/0052833	A1	3/2011	Hanawa et al.
2010/0151206	A1	6/2010	Wu et al.	2011/0053383	A1	3/2011	Shero et al.
2010/0159638	A1	6/2010	Jeong	2011/0056513	A1	3/2011	Hombach et al.
2010/0159707	A1	6/2010	Huang et al.	2011/0056626	A1	3/2011	Brown et al.
2010/0162752	A1	7/2010	Tabata et al.	2011/0057248	A1	3/2011	Ma et al.
2010/0162956	A1	7/2010	Murakami et al.	2011/0061810	A1	3/2011	Ganguly et al.
2010/0163524	A1	7/2010	Arai	2011/0065289	A1	3/2011	Asai
2010/0163937	A1	7/2010	Clendenning	2011/0067522	A1*	3/2011	Lai B62K 21/26 74/551.9
2010/0166630	A1	7/2010	Gu et al.	2011/0070380	A1	3/2011	Shero et al.
2010/0168404	A1	7/2010	Girolami et al.	2011/0070740	A1	3/2011	Bettencourt et al.
2010/0170441	A1	7/2010	Won et al.	2011/0081519	A1	4/2011	Dillingh
2010/0170868	A1	7/2010	Lin et al.	2011/0083496	A1	4/2011	Lin et al.
2010/0173432	A1	7/2010	White et al.	2011/0086516	A1	4/2011	Lee et al.
2010/0178137	A1	7/2010	Chintalapati et al.	2011/0089166	A1	4/2011	Hunter et al.
2010/0178423	A1	7/2010	Shimizu et al.	2011/0089469	A1	4/2011	Merckling
2010/0180819	A1	7/2010	Hatanaka et al.	2011/0092077	A1	4/2011	Xu et al.
2010/0183825	A1	7/2010	Becker et al.	2011/0097901	A1	4/2011	Banna et al.
2010/0184302	A1	7/2010	Lee et al.	2011/0107512	A1	5/2011	Gilbert
2010/0186669	A1	7/2010	Shin et al.	2011/0108194	A1	5/2011	Yoshioka et al.
2010/0193501	A1	8/2010	Zucker et al.	2011/0108741	A1	5/2011	Ingram
2010/0195392	A1	8/2010	Freeman	2011/0108929	A1	5/2011	Meng
2010/0202860	A1	8/2010	Reed	2011/0117490	A1	5/2011	Bae et al.
2010/0209598	A1	8/2010	Xu et al.	2011/0117492	A1	5/2011	Yamada et al.
2010/0221452	A1	9/2010	Kang	2011/0117737	A1	5/2011	Agarwala et al.
2010/0229795	A1	9/2010	Tanabe	2011/0117749	A1	5/2011	Sheu
2010/0229965	A1	9/2010	Kashima et al.	2011/0121503	A1	5/2011	Burrows et al.
2010/0230051	A1	9/2010	Iizuka	2011/0124196	A1	5/2011	Lee
2010/0230863	A1	9/2010	Moench et al.	2011/0139272	A1	6/2011	Matsumoto et al.
2010/0233885	A1	9/2010	Kushibiki et al.	2011/0139748	A1	6/2011	Donnelly et al.
2010/0233886	A1	9/2010	Yang et al.	2011/0140172	A1	6/2011	Chu
2010/0236691	A1	9/2010	Yamazaki	2011/0143032	A1	6/2011	Vrtis et al.
2010/0243166	A1	9/2010	Hayashi et al.	2011/0143461	A1	6/2011	Fish et al.
2010/0244688	A1	9/2010	Braun et al.	2011/0159200	A1	6/2011	Kogure
2010/0248465	A1	9/2010	Yi et al.	2011/0159202	A1	6/2011	Matsushita
2010/0255198	A1	10/2010	Cleary et al.	2011/0159673	A1	6/2011	Hanawa et al.
2010/0255218	A1	10/2010	Oka et al.	2011/0159680	A1	6/2011	Yoo
2010/0255625	A1	10/2010	De Vries	2011/0168330	A1	7/2011	Sakaue et al.
2010/0255658	A1	10/2010	Aggarwal	2011/0171775	A1	7/2011	Yamamoto et al.
2010/0259152	A1	10/2010	Yasuda et al.	2011/0175011	A1	7/2011	Ehrne et al.
2010/0266765	A1	10/2010	White et al.	2011/0180233	A1	7/2011	Bera et al.
2010/0267248	A1	10/2010	Ma et al.	2011/0183079	A1	7/2011	Jackson et al.
2010/0270675	A1	10/2010	Harada	2011/0183269	A1	7/2011	Zhu
2010/0246630	A1	11/2010	Kaszynski et al.	2011/0183527	A1	7/2011	Cho
2010/0275846	A1	11/2010	Kitagawa	2011/0192820	A1	8/2011	Yeom et al.
2010/0279008	A1	11/2010	Takagi	2011/0198417	A1	8/2011	Detmar et al.
2010/0282163	A1	11/2010	Aggarwal et al.	2011/0198736	A1	8/2011	Shero et al.
2010/0282170	A1	11/2010	Nishizawa	2011/0204025	A1	8/2011	Tahara
2010/0282645	A1	11/2010	Wang	2011/0210468	A1	9/2011	Shannon et al.
2010/0285237	A1	11/2010	Ditizio et al.	2011/0217838	A1	9/2011	Hsieh et al.
2010/0285319	A1	11/2010	Kwak et al.	2011/0220874	A1	9/2011	Hanrath
2010/0294199	A1	11/2010	Tran et al.	2011/0223334	A1	9/2011	Yudovsky et al.
2010/0297391	A1	11/2010	Kley	2011/0236600	A1	9/2011	Fox et al.
2010/0301752	A1	12/2010	Bakre et al.	2011/0237040	A1	9/2011	Ng et al.
2010/0304047	A1	12/2010	Yang et al.	2011/0239936	A1	10/2011	Suzaki et al.
2010/0307415	A1	12/2010	Shero et al.	2011/0253044	A1	10/2011	Tam et al.
2010/0317177	A1	12/2010	Huang et al.	2011/0254052	A1	10/2011	Kouvetakis
2010/0317198	A1	12/2010	Antonelli	2011/0256675	A1	10/2011	Avouris
2010/0322604	A1	12/2010	Fondurulia et al.	2011/0256726	A1	10/2011	Lavoie et al.
2010/0326358	A1	12/2010	Choi	2011/0256727	A1	10/2011	Beynet et al.
				2011/0256734	A1	10/2011	Hausmann et al.
				2011/0263107	A1	10/2011	Chung et al.
				2011/0264250	A1	10/2011	Nishimura et al.

(56)

References Cited

U.S. PATENT DOCUMENTS

2011/0265549	A1	11/2011	Cruse et al.	2012/0160172	A1	6/2012	Wamura et al.
2011/0265715	A1	11/2011	Keller	2012/0161405	A1	6/2012	Mohn
2011/0265725	A1	11/2011	Tsuji	2012/0164327	A1	6/2012	Sato
2011/0265951	A1	11/2011	Xu et al.	2012/0164837	A1	6/2012	Tan et al.
2011/0275018	A1	11/2011	Matteo et al.	2012/0164842	A1	6/2012	Watanabe
2011/0275166	A1	11/2011	Shero et al.	2012/0164846	A1	6/2012	Ha et al.
2011/0277690	A1	11/2011	Rozenzon et al.	2012/0170170	A1	7/2012	Gros-Jean
2011/0281417	A1	11/2011	Gordon et al.	2012/0171391	A1	7/2012	Won
2011/0283933	A1	11/2011	Makarov et al.	2012/0171874	A1	7/2012	Thridandam et al.
2011/0291243	A1	12/2011	Seamons	2012/0175518	A1	7/2012	Godet et al.
2011/0294075	A1	12/2011	Chen et al.	2012/0175751	A1	7/2012	Gatineau et al.
2011/0294288	A1	12/2011	Lee et al.	2012/0180719	A1	7/2012	Inoue et al.
2011/0298062	A1	12/2011	Ganguli et al.	2012/0180954	A1	7/2012	Yang et al.
2011/0300720	A1	12/2011	Fu	2012/0183689	A1	7/2012	Suzuki et al.
2011/0308453	A1	12/2011	Su et al.	2012/0187083	A1	7/2012	Hashizume
2011/0308460	A1	12/2011	Hong et al.	2012/0187305	A1	7/2012	Elam et al.
2011/0312191	A1	12/2011	Ohkura et al.	2012/0190178	A1	7/2012	Wang et al.
2011/0318888	A1	12/2011	Komatsu et al.	2012/0190185	A1	7/2012	Rogers
2012/0003500	A1	1/2012	Yoshida et al.	2012/0196048	A1	8/2012	Ueda
2012/0003726	A1	1/2012	Jones et al.	2012/0196450	A1	8/2012	Balseanu et al.
2012/0003831	A1	1/2012	Kang et al.	2012/0207456	A1	8/2012	Kim et al.
2012/0006489	A1	1/2012	Okita	2012/0212121	A1	8/2012	Lin
2012/0009802	A1	1/2012	Lavoie	2012/0214318	A1	8/2012	Fukazawa et al.
2012/0024223	A1	2/2012	Torres et al.	2012/0216743	A1	8/2012	Itoh et al.
2012/0024227	A1	2/2012	Takasuka et al.	2012/0219824	A1	8/2012	Prolier
2012/0024479	A1	2/2012	Palagashvili et al.	2012/0220139	A1	8/2012	Lee et al.
2012/0028454	A1	2/2012	Swaminathan et al.	2012/0225561	A1	9/2012	Watanabe
2012/0028469	A1	2/2012	Onizawa et al.	2012/0231771	A1	9/2012	Marcus
2012/0031333	A1	2/2012	Kurita et al.	2012/0238074	A1	9/2012	Santhanam et al.
2012/0032311	A1	2/2012	Gates	2012/0240858	A1	9/2012	Taniyama et al.
2012/0033695	A1	2/2012	Hayashi et al.	2012/0241411	A1	9/2012	Darling et al.
2012/0036732	A1	2/2012	Varadarajan	2012/0252229	A1	10/2012	Timans et al.
2012/0040528	A1	2/2012	Kim et al.	2012/0258257	A1	10/2012	Nguyen et al.
2012/0043556	A1	2/2012	Dube et al.	2012/0263876	A1	10/2012	Haukka et al.
2012/0046421	A1	2/2012	Darling et al.	2012/0264051	A1	10/2012	Angelov et al.
2012/0052681	A1	3/2012	Marsh	2012/0270339	A1	10/2012	Xie et al.
2012/0058270	A1	3/2012	Winter et al.	2012/0270393	A1	10/2012	Pore et al.
2012/0058630	A1	3/2012	Quinn	2012/0289053	A1	11/2012	Holland et al.
2012/0064690	A1	3/2012	Hirota et al.	2012/0289057	A1	11/2012	DeDontney
2012/0064764	A1*	3/2012	Islam H01R 9/0521 439/578	2012/0295427	A1	11/2012	Bauer
2012/0068242	A1	3/2012	Shin et al.	2012/0295449	A1	11/2012	Fukazawa
2012/0070136	A1	3/2012	Koelmel et al.	2012/0304935	A1	12/2012	Oosterlaken et al.
2012/0070997	A1	3/2012	Larson	2012/0305026	A1	12/2012	Nomura et al.
2012/0073400	A1*	3/2012	Wang B62K 21/26 74/551.9	2012/0305196	A1	12/2012	Mori et al.
2012/0074533	A1	3/2012	Aoyama	2012/0305987	A1	12/2012	Hirler et al.
2012/0077349	A1	3/2012	Li et al.	2012/0307588	A1	12/2012	Hanada et al.
2012/0080756	A1	4/2012	Suzuki	2012/0309181	A1	12/2012	Machkaoutsan et al.
2012/0088031	A1	4/2012	Neel	2012/0310440	A1	12/2012	Darabnia et al.
2012/0090704	A1	4/2012	Laverdiere et al.	2012/0315113	A1	12/2012	Hiroki
2012/0091522	A1	4/2012	Ozaki et al.	2012/0318334	A1	12/2012	Bedell et al.
2012/0098107	A1	4/2012	Raisanen et al.	2012/0318773	A1	12/2012	Wu et al.
2012/0100464	A1	4/2012	Kageyama	2012/0321786	A1	12/2012	Satitpunwaycha et al.
2012/0103264	A1	5/2012	Choi et al.	2012/0322252	A1	12/2012	Son et al.
2012/0103522	A1	5/2012	Hohenwater	2012/0325148	A1	12/2012	Yamagishi et al.
2012/0103939	A1	5/2012	Wu et al.	2012/0328780	A1	12/2012	Yamagishi et al.
2012/0107607	A1	5/2012	Takaki et al.	2013/0005122	A1	1/2013	Schwarzenbach et al.
2012/0108039	A1	5/2012	Zajaji	2013/0005147	A1	1/2013	Angyal et al.
2012/0108048	A1	5/2012	Lim et al.	2013/0011983	A1	1/2013	Tsai
2012/0114877	A1	5/2012	Lee	2013/0014697	A1	1/2013	Kanayama
2012/0115250	A1	5/2012	Ariga et al.	2013/0014896	A1	1/2013	Shoji et al.
2012/0115257	A1	5/2012	Matsuyam et al.	2013/0019944	A1	1/2013	Hekmatshoar-Tabari et al.
2012/0119337	A1	5/2012	Sasaki et al.	2013/0019945	A1	1/2013	Hekmatshoar-Tabari et al.
2012/0121823	A1	5/2012	Chhabra	2013/0019960	A1	1/2013	Choi et al.
2012/0122275	A1	5/2012	Koo et al.	2013/0020246	A1	1/2013	Hoots et al.
2012/0122302	A1	5/2012	Weisman et al.	2013/0023120	A1	1/2013	Yaehashi et al.
2012/0126300	A1	5/2012	Park et al.	2013/0023129	A1	1/2013	Reed
2012/0128897	A1	5/2012	Xiao et al.	2013/0025538	A1	1/2013	Collins et al.
2012/0135145	A1	5/2012	Je et al.	2013/0025786	A1	1/2013	Davidkovich et al.
2012/0139009	A1	6/2012	Ning et al.	2013/0026451	A1	1/2013	Bangsaruntip et al.
2012/0149207	A1	6/2012	Graff	2013/0037858	A1	2/2013	Hong et al.
2012/0149213	A1	6/2012	Nittala	2013/0037886	A1	2/2013	Tsai et al.
2012/0156108	A1	6/2012	Fondurulia et al.	2013/0040481	A1*	2/2013	Vallely H01R 13/111 439/312
2012/0156890	A1	6/2012	Yim et al.	2013/0042811	A1	2/2013	Shanker et al.
				2013/0048606	A1	2/2013	Mao et al.
				2013/0052585	A1	2/2013	Ayothi et al.
				2013/0059078	A1	3/2013	Gatineau et al.
				2013/0061755	A1	3/2013	Frederick
				2013/0064973	A1	3/2013	Chen et al.

(56)

References Cited

U.S. PATENT DOCUMENTS

2013/0065189	A1	3/2013	Yoshii et al.	2013/0309876	A1	11/2013	Ogawa
2013/0068727	A1	3/2013	Okita	2013/0312663	A1	11/2013	Khosla et al.
2013/0068970	A1	3/2013	Matsushita	2013/0313656	A1	11/2013	Tong
2013/0069052	A1	3/2013	Sandhu	2013/0319290	A1	12/2013	Xiao et al.
2013/0078376	A1	3/2013	Higashino et al.	2013/0320429	A1	12/2013	Thomas
2013/0078392	A1	3/2013	Xiao et al.	2013/0323435	A1	12/2013	Xiao et al.
2013/0081702	A1	4/2013	Mohammed et al.	2013/0323859	A1	12/2013	Chen et al.
2013/0082274	A1	4/2013	Yang	2013/0330165	A1	12/2013	Wimplinger
2013/0084156	A1	4/2013	Shimamoto	2013/0330911	A1	12/2013	Huang et al.
2013/0084714	A1	4/2013	Oka et al.	2013/0330933	A1	12/2013	Fukazawa et al.
2013/0089716	A1	4/2013	Krishnamurthy et al.	2013/0333619	A1	12/2013	Omari
2013/0093048	A1	4/2013	Chang et al.	2013/0337583	A1	12/2013	Kobayashi et al.
2013/0095664	A1	4/2013	Matero et al.	2013/0337639	A1	12/2013	Ivanstov et al.
2013/0095973	A1	4/2013	Kroneberger et al.	2013/0337653	A1	12/2013	Kovalgin et al.
2013/0104988	A1	5/2013	Yednak et al.	2013/0340619	A1	12/2013	Tammera
2013/0104992	A1	5/2013	Yednak et al.	2013/0344248	A1	12/2013	Clark
2013/0112251	A1	5/2013	Hang et al.	2014/0000843	A1	1/2014	Dunn et al.
2013/0115383	A1	5/2013	Lu et al.	2014/0001520	A1	1/2014	Glass
2013/0115763	A1	5/2013	Takamure et al.	2014/0004274	A1	1/2014	Thompson
2013/0115768	A1	5/2013	Pore et al.	2014/0014642	A1	1/2014	Elliot et al.
2013/0119018	A1	5/2013	Kanarik et al.	2014/0014644	A1	1/2014	Akiba et al.
2013/0122712	A1	5/2013	Kim et al.	2014/0015186	A1	1/2014	Wessel et al.
2013/0122722	A1	5/2013	Cissell et al.	2014/0017414	A1	1/2014	Fukazawa et al.
2013/0126515	A1	5/2013	Shero et al.	2014/0017908	A1	1/2014	Beynet et al.
2013/0129577	A1	5/2013	Halpin et al.	2014/0020619	A1	1/2014	Vincent et al.
2013/0134148	A1	5/2013	Tachikawa	2014/0023794	A1	1/2014	Mahajani et al.
2013/0143401	A1	6/2013	Yu et al.	2014/0027884	A1	1/2014	Tang et al.
2013/0157409	A1	6/2013	Vaidya	2014/0033978	A1	2/2014	Adachi et al.
2013/0160709	A1	6/2013	White	2014/0034632	A1	2/2014	Pan et al.
2013/0161629	A1	6/2013	Han et al.	2014/0036274	A1	2/2014	Marquardt et al.
2013/0168353	A1	7/2013	Okita et al.	2014/0047705	A1	2/2014	Singh
2013/0168354	A1	7/2013	Kanarik	2014/0048765	A1	2/2014	Ma et al.
2013/0171818	A1	7/2013	Kim et al.	2014/0056679	A1	2/2014	Yamabe et al.
2013/0175596	A1	7/2013	Cheng et al.	2014/0056770	A1	2/2014	Bedard et al.
2013/0180448	A1	7/2013	Sakaue et al.	2014/0057454	A1	2/2014	Subramonium
2013/0183814	A1	7/2013	Huang et al.	2014/0058179	A1	2/2014	Stevens et al.
2013/0189854	A1	7/2013	Hausmann et al.	2014/0060147	A1	3/2014	Sarin et al.
2013/0196502	A1	8/2013	Haukka et al.	2014/0061770	A1	3/2014	Lee
2013/0196507	A1	8/2013	Ma et al.	2014/0062304	A1	3/2014	Nakano et al.
2013/0200518	A1	8/2013	Ahmed et al.	2014/0065841	A1	3/2014	Matero
2013/0203266	A1	8/2013	Hintze	2014/0067110	A1	3/2014	Lawson et al.
2013/0203267	A1	8/2013	Pomarede et al.	2014/0073143	A1	3/2014	Alokozai et al.
2013/0209940	A1	8/2013	Sakamoto et al.	2014/0076861	A1	3/2014	Cornelius et al.
2013/0210241	A1	8/2013	Lavoie et al.	2014/0077240	A1	3/2014	Roucka et al.
2013/0214232	A1	8/2013	Tendulkar et al.	2014/0084341	A1	3/2014	Weeks
2013/0217239	A1	8/2013	Mallick et al.	2014/0087544	A1	3/2014	Tolle
2013/0217240	A1	8/2013	Mallick et al.	2014/0094027	A1	4/2014	Azumo et al.
2013/0217241	A1	8/2013	Underwood et al.	2014/0096716	A1	4/2014	Chung et al.
2013/0217243	A1	8/2013	Underwood et al.	2014/0097468	A1	4/2014	Okita
2013/0224964	A1	8/2013	Fukazawa	2014/0099798	A1	4/2014	Tsuji
2013/0228225	A1	9/2013	Leeser	2014/0103145	A1	4/2014	White et al.
2013/0230814	A1	9/2013	Dunn et al.	2014/0106574	A1	4/2014	Kang et al.
2013/0234203	A1	9/2013	Tsai et al.	2014/0110798	A1	4/2014	Cai
2013/0242287	A1	9/2013	Schlezinger	2014/0113457	A1	4/2014	Sims
2013/0256265	A1	10/2013	Darling et al.	2014/0116335	A1	5/2014	Tsuji et al.
2013/0256838	A1	10/2013	Sanchez et al.	2014/0117380	A1	5/2014	Loboda et al.
2013/0256962	A1	10/2013	Ranish	2014/0120487	A1	5/2014	Kaneko
2013/0264659	A1	10/2013	Jung	2014/0120678	A1	5/2014	Shinriki et al.
2013/0269612	A1	10/2013	Cheng et al.	2014/0120723	A1	5/2014	Fu et al.
2013/0270676	A1	10/2013	Lindert et al.	2014/0120738	A1	5/2014	Jung
2013/0276978	A1	10/2013	Bluck et al.	2014/0127907	A1	5/2014	Yang
2013/0280891	A1	10/2013	Kim et al.	2014/0138779	A1	5/2014	Xie et al.
2013/0285155	A1	10/2013	Glass	2014/0141165	A1	5/2014	Sato et al.
2013/0287526	A1	10/2013	Bluck et al.	2014/0141625	A1	5/2014	Fuzazawa et al.
2013/0288427	A1	10/2013	Hung et al.	2014/0144500	A1	5/2014	Cao et al.
2013/0288480	A1	10/2013	Sanchez et al.	2014/0158786	A1	6/2014	Santo
2013/0288485	A1	10/2013	Liang et al.	2014/0159170	A1	6/2014	Raisanen et al.
2013/0292047	A1	11/2013	Tian et al.	2014/0162401	A1	6/2014	Kawano et al.
2013/0292676	A1	11/2013	Milligan et al.	2014/0167187	A1	6/2014	Kuo et al.
2013/0292807	A1	11/2013	Raisanen et al.	2014/0174354	A1	6/2014	Arai
2013/0295779	A1	11/2013	Chandra et al.	2014/0175054	A1	6/2014	Carlson et al.
2013/0299944	A1	11/2013	Lai et al.	2014/0182053	A1	7/2014	Huang
2013/0302520	A1	11/2013	Wang et al.	2014/0191389	A1	7/2014	Lee et al.
2013/0302999	A1	11/2013	Won et al.	2014/0193983	A1	7/2014	Lavoie
2013/0303803	A1	11/2013	Doerr et al.	2014/0202386	A1	7/2014	Taga
				2014/0202388	A1	7/2014	Um et al.
				2014/0209976	A1	7/2014	Yang et al.
				2014/0217065	A1	8/2014	Winkler et al.
				2014/0220247	A1	8/2014	Hauldca et al.

(56)

References Cited

U.S. PATENT DOCUMENTS

2014/0225065	A1	8/2014	Rachmady et al.	2015/0162214	A1	6/2015	Thompson
2014/0227072	A1	8/2014	Lee et al.	2015/0167159	A1	6/2015	Halpin et al.
2014/0227444	A1	8/2014	Winter et al.	2015/0167162	A1	6/2015	Barik et al.
2014/0227861	A1	8/2014	Wu et al.	2015/0167165	A1	6/2015	Lindfors
2014/0227881	A1	8/2014	Lubomirsky et al.	2015/0167705	A1	6/2015	Lee et al.
2014/0231922	A1	8/2014	Kim et al.	2015/0170914	A1	6/2015	Haukka et al.
2014/0234466	A1	8/2014	Gao et al.	2015/0170947	A1	6/2015	Bluck
2014/0234550	A1	8/2014	Winter et al.	2015/0170954	A1	6/2015	Agarwal
2014/0234992	A1	8/2014	Kubota et al.	2015/0170975	A1	6/2015	Blatchford et al.
2014/0245948	A1	9/2014	Nguyen et al.	2015/0171177	A1	6/2015	Cheng et al.
2014/0251953	A1	9/2014	Winkler et al.	2015/0174768	A1	6/2015	Rodnick
2014/0251954	A1	9/2014	Winkler et al.	2015/0179501	A1	6/2015	Jhaveri et al.
2014/0252134	A1	9/2014	Chen	2015/0179564	A1	6/2015	Lee et al.
2014/0252479	A1	9/2014	Utomo et al.	2015/0179640	A1	6/2015	Kim et al.
2014/0260684	A1	9/2014	Christmann	2015/0184291	A1	7/2015	Alokozai et al.
2014/0262193	A1	9/2014	Im et al.	2015/0187559	A1	7/2015	Sano
2014/0264297	A1	9/2014	Kumar et al.	2015/0187568	A1	7/2015	Pettinger et al.
2014/0264902	A1	9/2014	Ting et al.	2015/0203961	A1	7/2015	Ha et al.
2014/0272194	A1	9/2014	Xiao et al.	2015/0217330	A1	8/2015	Haukka
2014/0273428	A1	9/2014	Shero	2015/0217456	A1	8/2015	Tsuji et al.
2014/0273477	A1	9/2014	Niskanen	2015/0218695	A1	8/2015	Odedra
2014/0273510	A1	9/2014	Chen et al.	2015/0225850	A1	8/2015	Arora et al.
2014/0273528	A1	9/2014	Niskanen	2015/0228572	A1	8/2015	Yang et al.
2014/0273530	A1	9/2014	Nguyen	2015/0228749	A1	8/2015	Ando et al.
2014/0273531	A1	9/2014	Niskanen	2015/0240357	A1	8/2015	Tachibana et al.
2014/0283747	A1	9/2014	Kasai et al.	2015/0240359	A1	8/2015	Jdira et al.
2014/0322862	A1	10/2014	Xie et al.	2015/0243542	A1	8/2015	Yoshihara et al.
2014/0322885	A1	10/2014	Xie et al.	2015/0243545	A1	8/2015	Tang
2014/0346142	A1	11/2014	Chapuis et al.	2015/0243658	A1	8/2015	Joshi et al.
2014/0346650	A1	11/2014	Raisanen et al.	2015/0255385	A1	9/2015	Lee et al.
2014/0349033	A1	11/2014	Nonaka et al.	2015/0259790	A1	9/2015	Newman
2014/0363980	A1	12/2014	Kawamata et al.	2015/0262828	A1	9/2015	Brand et al.
2014/0363983	A1	12/2014	Nakano et al.	2015/0263033	A1	9/2015	Aoyama
2014/0363985	A1	12/2014	Jang et al.	2015/0267295	A1	9/2015	Hill et al.
2014/0367043	A1	12/2014	Bishara et al.	2015/0267297	A1	9/2015	Shiba
2014/0367642	A1	12/2014	Guo	2015/0267298	A1	9/2015	Saitou et al.
2014/0377960	A1	12/2014	Koiwa	2015/0267299	A1	9/2015	Hawkins
2015/0004316	A1	1/2015	Thompson et al.	2015/0267301	A1	9/2015	Hill et al.
2015/0004317	A1	1/2015	Dussarrat et al.	2015/0270140	A1	9/2015	Gupta et al.
2015/0004798	A1	1/2015	Chandrasekharan et al.	2015/0270146	A1	9/2015	Yoshihara et al.
2015/0007770	A1	1/2015	Chandrasekharan et al.	2015/0279681	A1	10/2015	Knoops
2015/0010381	A1	1/2015	Cai	2015/0279708	A1	10/2015	Kobayashi et al.
2015/0014632	A1	1/2015	Kim et al.	2015/0279956	A1	10/2015	Ozaki et al.
2015/0014823	A1	1/2015	Mallikarjunan et al.	2015/0284848	A1	10/2015	Nakano et al.
2015/0017794	A1	1/2015	Takamure	2015/0287591	A1	10/2015	Pore et al.
2015/0021599	A1	1/2015	Ridgeway	2015/0287612	A1	10/2015	Luere et al.
2015/0024609	A1	1/2015	Milligan et al.	2015/0287626	A1	10/2015	Arai
2015/0031218	A1	1/2015	Karakawa	2015/0287710	A1	10/2015	Yun et al.
2015/0041431	A1	2/2015	Zafropoulo et al.	2015/0292088	A1	10/2015	Canizares
2015/0048485	A1	2/2015	Tolle	2015/0299848	A1	10/2015	Haukka et al.
2015/0056815	A1	2/2015	Fernandez	2015/0308586	A1	10/2015	Shugrue et al.
2015/0056821	A1	2/2015	Ishikawa	2015/0311151	A1	10/2015	Chi et al.
2015/0072509	A1	3/2015	Chi et al.	2015/0303056	A1	11/2015	Varadarajan et al.
2015/0078874	A1	3/2015	Sansoni	2015/0315704	A1	11/2015	Nakano et al.
2015/0079311	A1	3/2015	Nakano	2015/0322569	A1	11/2015	Kilpi et al.
2015/0086316	A1	3/2015	Greenberg	2015/0340247	A1	11/2015	Balakrishnan et al.
2015/0087154	A1	3/2015	Guha et al.	2015/0340500	A1	11/2015	Brunco
2015/0091057	A1	4/2015	Xie et al.	2015/0343741	A1	12/2015	Shibata et al.
2015/0091134	A1	4/2015	Amaratunga et al.	2015/0345018	A1	12/2015	Detavernier et al.
2015/0096973	A1	4/2015	Dunn et al.	2015/0348755	A1	12/2015	Han et al.
2015/0099065	A1	4/2015	Canizares et al.	2015/0353478	A1	12/2015	Hoshino et al.
2015/0099072	A1	4/2015	Takamure et al.	2015/0361553	A1	12/2015	Murakawa
2015/0099342	A1	4/2015	Tsai	2015/0364371	A1	12/2015	Yen
2015/0102466	A1	4/2015	Colinge	2015/0367253	A1	12/2015	Kanyal et al.
2015/0111374	A1	4/2015	Bao	2015/0372056	A1	12/2015	Seong et al.
2015/0111395	A1	4/2015	Hashimoto et al.	2015/0376211	A1	12/2015	Girard
2015/0122180	A1	5/2015	Chang et al.	2015/0376785	A1	12/2015	Knaapen et al.
2015/0132212	A1	5/2015	Winkler et al.	2015/0380296	A1	12/2015	Antonelli et al.
2015/0140210	A1	5/2015	Jung et al.	2016/0002776	A1	1/2016	Nal et al.
2015/0147483	A1	5/2015	Fukazawa	2016/0002786	A1	1/2016	Gatineau et al.
2015/0147488	A1	5/2015	Choi et al.	2016/0005595	A1	1/2016	Liu et al.
2015/0147875	A1	5/2015	Takamure et al.	2016/0013022	A1	1/2016	Ayoub
2015/0147877	A1	5/2015	Jung	2016/0013024	A1	1/2016	Milligan et al.
2015/0162168	A1	6/2015	Oehrlie	2016/0020092	A1	1/2016	Kang et al.
2015/0162185	A1	6/2015	Pore	2016/0024655	A1	1/2016	Yudovsky et al.
				2016/0024656	A1	1/2016	White et al.
				2016/0035566	A1	2/2016	LaVoie
				2016/0042954	A1	2/2016	Sung et al.
				2016/0051964	A1	2/2016	Tolle et al.

(56)

References Cited

U.S. PATENT DOCUMENTS

2016/0056074	A1	2/2016	Na	2017/0040164	A1	2/2017	Wang et al.
2016/0071750	A1	3/2016	de Ridder et al.	2017/0040206	A1	2/2017	Schmotzer et al.
2016/0079054	A1	3/2016	Chen et al.	2017/0044664	A1	2/2017	Dussarrat et al.
2016/0085003	A1	3/2016	Jaiswal	2017/0047446	A1	2/2017	Margetis et al.
2016/0097123	A1	4/2016	Shugrue et al.	2017/0051405	A1	2/2017	Fukazawa et al.
2016/0099150	A1	4/2016	Tsai	2017/0051406	A1	2/2017	Mori et al.
2016/0099250	A1	4/2016	Rabkin et al.	2017/0051408	A1	2/2017	Kosuke et al.
2016/0102214	A1	4/2016	Dietz et al.	2017/0053811	A1	2/2017	Fung et al.
2016/0111272	A1	4/2016	Girard	2017/0062204	A1	3/2017	Suzuki et al.
2016/0111438	A1	4/2016	Tsutsumi et al.	2017/0062209	A1	3/2017	Shiba
2016/0115590	A1	4/2016	Haukka et al.	2017/0062258	A1	3/2017	Bluck
2016/0133307	A1	5/2016	Lee et al.	2017/0091320	A1	3/2017	Psota et al.
2016/0133628	A1	5/2016	Xie	2017/0092469	A1	3/2017	Kurita et al.
2016/0141172	A1	5/2016	Kang	2017/0092531	A1	3/2017	Coomer
2016/0145738	A1	5/2016	Liu et al.	2017/0092535	A1	3/2017	Kimihiko et al.
2016/0148800	A1	5/2016	Henri et al.	2017/0092847	A1	3/2017	Kim et al.
2016/0148806	A1	5/2016	Henri et al.	2017/0100742	A1	4/2017	Pore et al.
2016/0148811	A1	5/2016	Nakatani et al.	2017/0103907	A1	4/2017	Chu et al.
2016/0148821	A1	5/2016	Singh	2017/0104061	A1	4/2017	Peng et al.
2016/0155629	A1	6/2016	Hawryluk et al.	2017/0107621	A1	4/2017	Suemori
2016/0163556	A1	6/2016	Briggs et al.	2017/0110313	A1	4/2017	Tang et al.
2016/0163558	A1	6/2016	Hudson et al.	2017/0110601	A1	4/2017	Blomberg et al.
2016/0163561	A1	6/2016	Hudson et al.	2017/0114464	A1	4/2017	Iriuda et al.
2016/0163711	A1	6/2016	Arndt et al.	2017/0117141	A1	4/2017	Zhu et al.
2016/0168699	A1	6/2016	Fukazawa et al.	2017/0117202	A1	4/2017	Tang et al.
2016/0172189	A1	6/2016	Tapily	2017/0117203	A1	4/2017	Tang et al.
2016/0181128	A1	6/2016	Mori	2017/0117222	A1	4/2017	Kim et al.
2016/0181368	A1	6/2016	Weeks	2017/0130332	A1	5/2017	Stumpf
2016/0190137	A1	6/2016	Tsai et al.	2017/0136578	A1	5/2017	Yoshimura
2016/0362813	A1	6/2016	Bao et al.	2017/0140925	A1	5/2017	Suzuki et al.
2016/0196970	A1	7/2016	Takamure et al.	2017/0145564	A1	5/2017	Bertuch et al.
2016/0211135	A1	7/2016	Noda et al.	2017/0148918	A1	5/2017	Ye et al.
2016/0211147	A1	7/2016	Fukazawa	2017/0154757	A1	6/2017	Winkler et al.
2016/0217857	A1	7/2016	Paudel	2017/0173696	A1	6/2017	Sheinman
2016/0222504	A1	8/2016	Haukka et al.	2017/0178899	A1	6/2017	Kabansky et al.
2016/0225607	A1	8/2016	Yamamoto et al.	2017/0186754	A1	6/2017	Blomberg et al.
2016/0245704	A1	8/2016	Osaka et al.	2017/0191164	A1	7/2017	Alokozai et al.
2016/0256187	A1	9/2016	Shelton et al.	2017/0196562	A1	7/2017	Shelton
2016/0268102	A1	9/2016	White	2017/0200622	A1	7/2017	Shiokawa et al.
2016/0268107	A1	9/2016	White	2017/0216762	A1	8/2017	Shugrue et al.
2016/0273106	A1	9/2016	Kanjolia et al.	2017/0226636	A1	8/2017	Xiao
2016/0276148	A1	9/2016	Qian et al.	2017/0232457	A1	8/2017	Toshiki et al.
2016/0276212	A1	9/2016	Horikoshi	2017/0243734	A1	8/2017	Ishikawa et al.
2016/0281223	A1	9/2016	Sowa et al.	2017/0250068	A1	8/2017	Ishikawa et al.
2016/0284542	A1	9/2016	Noda et al.	2017/0250075	A1	8/2017	Caymax et al.
2016/0289828	A1	10/2016	Shero et al.	2017/0256417	A1	9/2017	Chou
2016/0293398	A1	10/2016	Danek et al.	2017/0256429	A1	9/2017	Lawson et al.
2016/0307766	A1	10/2016	Jongbloed et al.	2017/0260649	A1	9/2017	Coomer
2016/0312360	A1	10/2016	Rasheed et al.	2017/0263437	A1	9/2017	Li et al.
2016/0314962	A1	10/2016	Higashino et al.	2017/0267527	A1	9/2017	Kim et al.
2016/0314964	A1	10/2016	Tang et al.	2017/0267531	A1	9/2017	Huakka
2016/0334709	A1	11/2016	Huli et al.	2017/0271256	A1	9/2017	Inatsuka
2016/0336392	A1	11/2016	Tominaga et al.	2017/0271501	A1	9/2017	Avci et al.
2016/0358772	A1	12/2016	Xie	2017/0278705	A1	9/2017	Murakami et al.
2016/0362783	A1	12/2016	Tolle et al.	2017/0278707	A1	9/2017	Margetis et al.
2016/0365280	A1	12/2016	Brink et al.	2017/0287681	A1	10/2017	Nitadori et al.
2016/0365414	A1	12/2016	Peng et al.	2017/0294318	A1	10/2017	Yoshida et al.
2016/0372321	A1	12/2016	Krishnan et al.	2017/0306478	A1	10/2017	Raisanen et al.
2016/0372365	A1	12/2016	Tang et al.	2017/0306479	A1	10/2017	Raisanen et al.
2016/0372744	A1	12/2016	Essaki et al.	2017/0306480	A1	10/2017	Zhu et al.
2016/0376700	A1	12/2016	Haukka	2017/0316933	A1	11/2017	Xie et al.
2016/0376704	A1	12/2016	Raisanen	2017/0316940	A1	11/2017	Ishikawa et al.
2016/0379826	A9	12/2016	Arghavani et al.	2017/0317194	A1	11/2017	Tang et al.
2016/0379851	A1	12/2016	Swaminathan et al.	2017/0338111	A1	11/2017	Takamure et al.
2016/0381732	A1	12/2016	Moench et al.	2017/0338133	A1	11/2017	Tan et al.
2017/0009367	A1	1/2017	Harris et al.	2017/0338134	A1	11/2017	Tan et al.
2017/0011889	A1	1/2017	Winkler et al.	2017/0338192	A1	11/2017	Lee et al.
2017/0011950	A1	1/2017	Schmotzer	2017/0342559	A1	11/2017	Fukazawa et al.
2017/0018477	A1	1/2017	Kato	2017/0343896	A1	11/2017	Darling et al.
2017/0018570	A1	1/2017	Lue et al.	2017/0358482	A1	12/2017	Chen et al.
2017/0025280	A1	1/2017	Milligan	2017/0358670	A1	12/2017	Kub et al.
2017/0025291	A1	1/2017	Lin	2017/0365467	A1	12/2017	Shimamoto et al.
2017/0029945	A1	2/2017	Kamakura	2017/0372884	A1	12/2017	Margetis et al.
2017/0033004	A1	2/2017	Siew et al.	2017/0373188	A1	12/2017	Mochizuki et al.
2017/0037513	A1	2/2017	Haukka	2018/0005814	A1	1/2018	Kumar et al.
				2018/0010247	A1	1/2018	Niskanen
				2018/0019165	A1	1/2018	Baum et al.
				2018/0025890	A1	1/2018	Choi
				2018/0025939	A1	1/2018	Kovalgin et al.

(56)

References Cited

U.S. PATENT DOCUMENTS

2018/0033616	A1	2/2018	Masaru	2018/0350587	A1	12/2018	Jia et al.
2018/0033625	A1	2/2018	Yoo	2018/0350588	A1	12/2018	Raisanen et al.
2018/0033645	A1	2/2018	Saido et al.	2018/0350620	A1	12/2018	Zaitso et al.
2018/0033674	A1	2/2018	Jeong	2018/0350653	A1	12/2018	Jeong et al.
2018/0033679	A1	2/2018	Pore	2018/0355480	A1	12/2018	Kondo
2018/0040746	A1	2/2018	Johnson et al.	2018/0363131	A1	12/2018	Lee et al.
2018/0047749	A1	2/2018	Kim	2018/0363139	A1	12/2018	Rajavelu et al.
2018/0053660	A1	2/2018	Jandl et al.	2018/0366314	A1	12/2018	Niskanen et al.
2018/0053769	A1	2/2018	Kim et al.	2019/0003050	A1	1/2019	Dezelah et al.
2018/0057937	A1	3/2018	Lee et al.	2019/0003052	A1	1/2019	Shero et al.
2018/0061628	A1	3/2018	Ou et al.	2019/0006797	A1*	1/2019	Paynter H01R 24/564
2018/0061851	A1	3/2018	Ootsuka	2019/0013199	A1	1/2019	Bhargava et al.
2018/0068844	A1	3/2018	Chen et al.	2019/0019670	A1	1/2019	Lin et al.
2018/0068862	A1	3/2018	Terakura et al.	2019/0027573	A1	1/2019	Zhu et al.
2018/0068950	A1	3/2018	Bruley et al.	2019/0027583	A1	1/2019	Margetis et al.
2018/0069019	A1	3/2018	Kim et al.	2019/0027584	A1	1/2019	Margetis et al.
2018/0076021	A1	3/2018	Fukushima et al.	2019/0027605	A1	1/2019	Tolle et al.
2018/0083435	A1	3/2018	Redler	2019/0032209	A1	1/2019	Huggare
2018/0087152	A1	3/2018	Yoshida	2019/0032998	A1	1/2019	Jdira et al.
2018/0087154	A1	3/2018	Pore et al.	2019/0035605	A1	1/2019	Suzuki
2018/0087156	A1	3/2018	Kohei et al.	2019/0035647	A1	1/2019	Lee et al.
2018/0090583	A1	3/2018	Choi et al.	2019/0035810	A1	1/2019	Chun et al.
2018/0094351	A1	4/2018	Vergheese et al.	2019/0040529	A1	2/2019	Verbaas et al.
2018/0097076	A1	4/2018	Cheng et al.	2019/0051544	A1	2/2019	Verbaas
2018/0102276	A1	4/2018	Zhu et al.	2019/0051548	A1	2/2019	den Hartog Besselink et al.
2018/0105930	A1	4/2018	Kang et al.	2019/0051555	A1	2/2019	Hill et al.
2018/0108587	A1	4/2018	Jiang	2019/0057857	A1	2/2019	Ishikawa et al.
2018/0114680	A1	4/2018	Kim et al.	2019/0057858	A1	2/2019	Hausmann et al.
2018/0119283	A1	5/2018	Fukazawa	2019/0062907	A1	2/2019	Kim et al.
2018/0122642	A1	5/2018	Raisanen	2019/0066978	A1	2/2019	Um et al.
2018/0122709	A1	5/2018	Xie	2019/0066997	A1	2/2019	Klaver et al.
2018/0122959	A1	5/2018	Calka et al.	2019/0067003	A1	2/2019	Zope et al.
2018/0127876	A1	5/2018	Tolle et al.	2019/0067004	A1	2/2019	Kohen et al.
2018/0130652	A1	5/2018	Pettinger et al.	2019/0067014	A1	2/2019	Shrestha et al.
2018/0130701	A1	5/2018	Chun	2019/0067016	A1	2/2019	Zhu et al.
2018/0135173	A1	5/2018	Kim et al.	2019/0067094	A1	2/2019	Zope et al.
2018/0135179	A1	5/2018	Toshiyuki et al.	2019/0067095	A1	2/2019	Zhu et al.
2018/0142353	A1	5/2018	Tetsuya et al.	2019/0080903	A1	3/2019	Abel et al.
2018/0142357	A1	5/2018	Yoshikazu	2019/0081072	A1	3/2019	Chun et al.
2018/0151346	A1	5/2018	Blanquart	2019/0086807	A1	3/2019	Kachel et al.
2018/0151358	A1	5/2018	Margetis et al.	2019/0088555	A1	3/2019	Xie et al.
2018/0151588	A1	5/2018	Tsutsumi et al.	2019/0089143	A1*	3/2019	Malone H02G 15/064
2018/0155836	A1	6/2018	Arai et al.	2019/0093221	A1	3/2019	Jdira et al.
2018/0158688	A1	6/2018	Chen	2019/0096708	A1	3/2019	Sharma
2018/0158716	A1	6/2018	Konkola et al.	2019/0106788	A1	4/2019	Hawkins et al.
2018/0163305	A1	6/2018	Batzer et al.	2019/0109002	A1	4/2019	Mattinen et al.
2018/0166258	A1	6/2018	Kim et al.	2019/0109009	A1	4/2019	Longrie et al.
2018/0166315	A1	6/2018	Coomer	2019/0115206	A1	4/2019	Kim et al.
2018/0171475	A1	6/2018	Maes et al.	2019/0115237	A1	4/2019	den Hartog Besselink et al.
2018/0171477	A1	6/2018	Kim et al.	2019/0131124	A1	5/2019	Kohen et al.
2018/0174801	A1	6/2018	Chen et al.	2019/0140067	A1	5/2019	Zhu et al.
2018/0174826	A1	6/2018	Raaijmakers et al.	2019/0148224	A1	5/2019	Kuroda et al.
2018/0180509	A1	6/2018	Sawachi et al.	2019/0148398	A1	5/2019	Kim et al.
2018/0182613	A1	6/2018	Blanquart et al.	2019/0153593	A1	5/2019	Zhu et al.
2018/0182618	A1	6/2018	Blanquart et al.	2019/0157054	A1	5/2019	White et al.
2018/0189923	A1	7/2018	Zhong et al.	2019/0157067	A1	5/2019	Bhuyan et al.
2018/0195174	A1	7/2018	Kim et al.	2019/0163056	A1	5/2019	Maes et al.
2018/0211834	A1	7/2018	Takamure et al.	2019/0164763	A1	5/2019	Raisanen et al.
2018/0223429	A1	8/2018	Fukazawa et al.	2019/0221433	A1	7/2019	Raisanen
2018/0233372	A1	8/2018	Vayrynen et al.	2019/0229008	A1	7/2019	Rokkam et al.
2018/0258532	A1	9/2018	Kato et al.	2019/0244803	A1	8/2019	Suzuki
2018/0269057	A1	9/2018	Lei et al.	2019/0249300	A1	8/2019	Hatanpaa et al.
2018/0286638	A1	10/2018	Susa	2019/0249303	A1	8/2019	Kuroda et al.
2018/0286663	A1	10/2018	Kobayashi et al.	2019/0252195	A1	8/2019	Haukka
2018/0286672	A1	10/2018	Van Aerde et al.	2019/0252196	A1	8/2019	Vayrynen et al.
2018/0286675	A1	10/2018	Blomberg et al.	2019/0272993	A1	9/2019	Mattinen et al.
2018/0286711	A1	10/2018	Oosterlaken et al.	2019/0276934	A1	9/2019	Vergheese et al.
2018/0294187	A1	10/2018	Thombare et al.	2019/0287769	A1	9/2019	Blomberg et al.
2018/0308701	A1	10/2018	Na et al.	2019/0295837	A1	9/2019	Pore et al.
2018/0315838	A1	11/2018	Morrow et al.	2019/0304776	A1	10/2019	Choi
2018/0323055	A1	11/2018	Woodruff et al.	2019/0304780	A1	10/2019	Kohen et al.
2018/0323056	A1	11/2018	Woodruff et al.	2019/0304790	A1	10/2019	Mousa et al.
2018/0323059	A1	11/2018	Bhargava et al.	2019/0304821	A1	10/2019	Pierreux et al.
2018/0325414	A1	11/2018	Marashdeh et al.	2019/0311940	A1	10/2019	Choi et al.
2018/0331117	A1	11/2018	Titus et al.	2019/0318923	A1	10/2019	Blanquart et al.
				2019/0330740	A1	10/2019	Klaver
				2019/0346300	A1	11/2019	Kim et al.
				2019/0348261	A1	11/2019	Lin et al.
				2019/0348273	A1	11/2019	Tang et al.

(56)

References Cited

U.S. PATENT DOCUMENTS

2019/0348515 A1 11/2019 Li et al.
 2019/0363006 A1 11/2019 Min
 2019/0297710 A1 12/2019 Lindfors
 2019/0368040 A1 12/2019 Kachel et al.
 2019/0368041 A1 12/2019 Sreeram et al.
 2019/0371640 A1 12/2019 Raisanen et al.

FOREIGN PATENT DOCUMENTS

CN	1655362	8/2005	JP	11-097163	4/1999
CN	1664987	9/2005	JP	H11-097163	4/1999
CN	1825535	8/2006	JP	H11-118615	4/1999
CN	101330015	12/2008	JP	H11-183264	7/1999
CN	101522943	9/2009	JP	H11-183265	7/1999
CN	101681873	3/2010	JP	H11-195688	7/1999
CN	101423937	9/2011	JP	H11-287715	10/1999
CN	102383106	3/2012	JP	2001-15698	1/2001
CN	102373440	7/2014	JP	2001015698	1/2001
DE	3836696	12/1989	JP	2001023872	1/2001
DE	102008052750	6/2009	JP	2001207265	7/2001
EP	0887632	12/1998	JP	2001207268	7/2001
EP	1889817	2/2008	JP	2001210602	8/2001
EP	2036600	3/2009	JP	2001220677	8/2001
EP	2426233	7/2012	JP	2001287180	10/2001
FR	1408266	8/1965	JP	2001342570	12/2001
FR	2233614	1/1975	JP	2002164342	6/2002
GB	752-277	7/1956	JP	2002170781	6/2002
JP	58-19462	4/1983	JP	2002237375	8/2002
JP	59-211779	11/1984	JP	2003035574	2/2003
JP	61038863	2/1986	JP	2003053688	2/2003
JP	H01296613	11/1989	JP	2003133300	5/2003
JP	H0293071	4/1990	JP	2003153706	5/2003
JP	H02-185038	7/1990	JP	2003303814	10/2003
JP	03-044472	2/1991	JP	2004014952	1/2004
JP	H03-044472	2/1991	JP	2004023043	1/2004
JP	H03-155625	7/1991	JP	2004091848	3/2004
JP	H03-248427	11/1991	JP	2004113270	4/2004
JP	H0429313	1/1992	JP	2004128019	4/2004
JP	H04029313	1/1992	JP	2004134553	4/2004
JP	H04-115531	4/1992	JP	2004163293	6/2004
JP	H04115531	4/1992	JP	2004294638	10/2004
JP	H05-23079	3/1993	JP	2004310019	11/2004
JP	H05-118928	5/1993	JP	2004538374	12/2004
JP	05171446	7/1993	JP	2005033221	2/2005
JP	H05-171446	7/1993	JP	2005079254	3/2005
JP	H06-053210	2/1994	JP	2005507030	3/2005
JP	H0684888	3/1994	JP	2005172489	6/2005
JP	6204231	7/1994	JP	2006049352	2/2006
JP	H06319177	11/1994	JP	2006059931	3/2006
JP	H06-338497	12/1994	JP	2006090762	4/2006
JP	H0729836	1/1995	JP	2006153706	6/2006
JP	H07297271	1/1995	JP	2006186271	7/2006
JP	H07-109576	4/1995	JP	2006188729	7/2006
JP	07-034936	8/1995	JP	2006278058	10/2006
JP	H07-034936	8/1995	JP	2006319261	11/2006
JP	H07225214	8/1995	JP	2007027777	2/2007
JP	7-272694	10/1995	JP	3140111	3/2008
JP	H07-283149	10/1995	JP	2008060304	3/2008
JP	H07283149	10/1995	JP	2008066159	3/2008
JP	H07-209093	11/1995	JP	2008085129	4/2008
JP	08-181135	7/1996	JP	2008089320	4/2008
JP	H08181135	7/1996	JP	2008172083	7/2008
JP	H08-335558	12/1996	JP	2008527748	7/2008
JP	H08335558	12/1996	JP	2008198629	8/2008
JP	H09064149	3/1997	JP	2008202107	9/2008
JP	9-89676	4/1997	JP	2009016815	1/2009
JP	H09148322	6/1997	JP	2009088421	4/2009
JP	H10041096	2/1998	JP	2009239082	4/2009
JP	10-064696	3/1998	JP	2009099938	5/2009
JP	H10-064696	3/1998	JP	2009194248	8/2009
JP	H10-153494	6/1998	JP	2009251216	10/2009
JP	H10-227703	8/1998	JP	2009252851	10/2009
JP	10-0261620	9/1998	JP	2010067940	3/2010
JP	H10-0261620	9/1998	JP	2010097834	4/2010
JP	2845163	1/1999	JP	2010205967	9/2010
			JP	2010251444	10/2010
			JP	2010255218	11/2010
			JP	2011049592	3/2011
			JP	2011162830	8/2011
			JP	2011181681	9/2011
			JP	2011049592	10/2011
			JP	2012089837	5/2012
			JP	2012146939	8/2012
			JP	2012164736	8/2012
			JP	2012195513	10/2012
			JP	2013026479	2/2013
			JP	2013235912	11/2013
			JP	2014522104	8/2014

(56)

References Cited

FOREIGN PATENT DOCUMENTS		
JP	2016098406	5/2016
JP	2010123843	6/2016
JP	2016174158	9/2016
JP	2017183242	10/2017
KR	1998-0026850	7/1998
KR	100253664	4/2000
KR	10-2000-0031098	6/2000
KR	10-2000-0045257	7/2000
KR	10-0295043	4/2001
KR	10-2002-0064028	8/2002
KR	2002-0086763	11/2002
KR	10-0377095	3/2003
KR	2003-0092305	12/2003
KR	10-2005-0054122	6/2005
KR	10-0547248	1/2006
KR	10-0593960	6/2006
KR	10-0688484	2/2007
KR	10-2007-0084683	8/2007
KR	10-2009-0055443	6/2009
KR	10-2010-0020834	2/2010
KR	20100020834	2/2010
KR	10-2010-0032812	3/2010
KR	20100032812	3/2010
KR	20100079920	7/2010
KR	10-1114219	3/2012
KR	10-1535573	7/2015
SU	494614	2/1976
SU	1408319	7/1988
TW	538327	6/2003
TW	540093	7/2003
TW	1226380	1/2005
TW	M292692	6/2006
TW	200701301	1/2007
TW	200731357	8/2007
TW	201247690	12/2012
TW	201330086	7/2013
WO	1996017107	6/1996
WO	1997003223	1/1997
WO	1998032893	7/1998
WO	1999023690	5/1999
WO	DM/048579	7/1999
WO	DM/048579	9/1999
WO	2004008491	7/2002
WO	2004008827	1/2004
WO	2004010467	1/2004
WO	2004106584	12/2004
WO	2005112082	11/2005
WO	2006035281	4/2006
WO	2006054854	5/2006
WO	2006056091	6/2006
WO	2006078666	7/2006
WO	2006080782	8/2006
WO	2006097525	9/2006
WO	2006101857	9/2006
WO	2006114781	11/2006
WO	2007024720	3/2007
WO	2007027165	3/2007
WO	2007117718	10/2007
WO	2007131051	11/2007
WO	2007140376	12/2007
WO	2008045972	4/2008
WO	2008091900	7/2008
WO	2008121463	10/2008
WO	2008147731	12/2008
WO	2009028619	3/2009
WO	2009029532	3/2009
WO	2009039251	3/2009
WO	2009099776	8/2009
WO	2009154889	12/2009
WO	2009154896	12/2009
WO	2010039363	4/2010
WO	2010077533	7/2010
WO	2010100702	9/2010
WO	2010118051	10/2010
WO	2010129428	11/2010

WO	2010129430	11/2010
WO	2010129431	11/2010
WO	2010118051	1/2011
WO	2011019950	2/2011
WO	2011149640	12/2011
WO	2012077590	6/2012
WO	2013078065	5/2013
WO	2013078066	5/2013
WO	2014107290	7/2014
WO	2015026230	2/2015
WO	2015107009	7/2015
WO	2015112728	7/2015
WO	2018109553	6/2016
WO	2018109554	6/2016
WO	2017108713	6/2017
WO	2017108714	6/2017
WO	2017212546	12/2017
WO	2018003072	1/2018
WO	2018008088	1/2018
WO	2018013778	1/2018
WO	2018020316	2/2018
WO	2018020318	2/2018
WO	2018020320	2/2018
WO	2018020327	2/2018
WO	2008045972	4/2018
WO	20181095C51	6/2018
WO	2018109552	6/2018
WO	2018178771	10/2018
WO	2019030565	2/2019
WO	2019142055	7/2019
WO	2019158960	8/2019
WO	2019229537	12/2019

OTHER PUBLICATIONS

Paul Sellers BLog, paulsellers.com, site visited Apr. 22, 2020.*
 EPO; Extended European Search Report dated Apr. 28, 2014 in Application No. 11162225.4.
 EPO; Notice of Allowance dated Feb. 3, 2015 in Application No. 11162225.4.
 IPOS; Notice of Allowance dated Aug. 14, 2017 in Application No. 10201401237.
 JPO; Office Action dated Mar. 27, 2012 in Application No. 2009-532567.
 JPO; Notice of Allowance dated Jul. 31, 2012 in Application No. 2009-532567.
 JPO; Office Action dated May 9, 2013 in Application No. 2010058415.
 JPO; Office Action dated Nov. 5, 2013 in Application No. 2010058415.
 JPO; Office Action dated Aug. 29, 2014 in Application No. 2010058415.
 JPO; Notice of Allowance dated Dec. 24, 2014 in Application No. 2010058415.
 JPO; Office Action dated Aug. 26, 2013 in Application No. 2010-153754.
 JPO; Office Action dated Nov. 5, 2013 in Application No. 2010-193285.
 JPO; Notice of Allowance dated Apr. 2, 2013 in Application No. 2010-509478.
 JPO; Office Action dated Aug. 31, 2015 in Application No. 2011-284831.
 JPO; Notice of Allowance dated Mar. 9, 2016 in Application No. 2011-284831.
 JPO; Notice of Allowance dated Dec. 21, 2012 in Application No. 2011-514650.
 JPO; Office Action dated Dec. 15, 2014 in Application No. 2011090067.
 JPO; Notice of Allowance dated May 1, 2015 in Application No. 2011090067.
 JPO; Office Action dated Jul. 19, 2016 in Application No. 2012-153698.
 JPO; Notice of Allowance dated Oct. 26, 2016 in Application No. 2012-153698.
 JPO; Notice of Allowance dated Jun. 12, 2015 in Application No. 2012-504786.
 JPO; Notice of Allowance dated Jul. 2, 2013 in Application No. 2012-509857.

(56)

References Cited

OTHER PUBLICATIONS

JPO; Office Action dated May 31, 2017 in Application No. 2013-160173.
JPO; Notice of Allowance dated Aug. 25, 2017 in Application No. 2013-160173.
JPO; Office Action dated Jun. 15, 2017 in Application No. 2013-178344.
JPO; Office Action dated Jan. 29, 2018 in Application No. 2013-178344.
JPO; Notice of Allowance dated Aug. 21, 2018 in Application No. 2013-178344.
JPO; Office Action dated Apr. 10, 2018 in Application No. 2014-120675.
JPO; Notice of Allowance dated Jun. 12, 2018 in Application No. 2014-120675.
JPO; Office Action dated Apr. 3, 2018 in Application No. 2014-188835.
JPO; Notice of Allowance dated Jun. 12, 2018 in Application No. 2014-188835.
JPO; Office Action dated May 8, 2018 in Application No. 2014-205548.
JPO; Notice of Allowance dated May 22, 2018 in Application No. 2014-216540.
JPO; Office Action dated Jul. 31, 2018 in Application No. 2015-034774.
KIPO; Notice of Allowance dated Sep. 29, 2016 in Application No. 10-2010-0028336.
KIPO; Notice of Allowance dated Dec. 1, 2016 in Application No. 10-2010-0067768.
KIPO; Notice of Allowance dated Mar. 7, 2017 in Application No. 10-2010-0082446.
KIPO; Office Action dated Mar. 13, 2017 in Application No. 20110034612.
KIPO; Office Action dated Jul. 20, 2017 in Application No. 20110034612.
KIPO; Notice of Allowance dated Sep. 1, 2017 in Application No. 20110034612.
KIPO; Notice of Allowance dated Oct. 24, 2018 in Application No. 10-2010-0036449.
KIPO; Notice of Allowance dated Jan. 11, 2018 in Application No. 10-2011-0087600.
KIPO; Notice of Allowance Dated Mar. 14, 2018 in Application No. 10-2011-0142924.
KIPO; Notice of Allowance Dated Jun. 2, 2016 in Application No. 10-2011-7023416.
KIPO; Notice of Allowance dated Feb. 28, 2018 in Application No. 10-2012-0041878.
KIPO; Notice of Allowance dated May 30, 2018 in Application No. 10-2012-0042518.
KIPO; Office Action dated Dec. 13, 2018 in Application No. 10-2012-0064526.
KIPO; Notice of Allowance dated Nov. 22, 2018 in Application No. 10-2012-0103114.
KIPO; Notice of Allowance dated Feb. 23, 2018 in Application No. 10-2014-7017112.
KIPO; Notice of Allowance dated May 30, 2017 in Application No. 10-2016-7023913.
KIPO; Notice of Allowance dated Jul. 19, 2018 in Application No. 20187013945.
KIPO; Notice of Allowance dated Jan. 19, 2018 in Application No. 30-2017-0001320.
KIPO; Notice of Allowance dated Jul. 1, 2018 in Application No. 30-2017-0052872.
KIPO; Notice of Allowance dated Oct. 16, 2018 in Application No. 30-2018-0006016.
SIPO; Notice of Allowance dated May 8, 2015 in Application No. 201080015699.9.
SIPO; Notice of Allowance dated Aug. 22, 2014 in Application No. 201080020267.7.

SIPO; Notice of Allowance dated Oct. 16, 2015 in Application No. 201080020268.1.
SIPO; Notice of Allowance dated Oct. 24, 2014 in Application No. 201080036764.6.
SIPO; Notice of Allowance dated Aug. 26, 2015 in Application No. 201110155056.
SIPO; Notice of Allowance dated Apr. 13, 2017 in Application No. 201210201995.9.
SIPO; Notice of Allowance dated Jun. 16, 2016 in Application No. 201280057466.4.
SIPO; Notice of Allowance dated Jan. 3, 2017 in Application No. 201280057542.1.
SIPO; Notice of Allowance dated Jul. 20, 2017 in Application No. 201310412808.6.
SIPO; Notice of Allowance dated May 25, 2017 in Application No. 201730010308.9.
SIPO; Notice of Allowance dated Oct. 24, 2018 in Application No. 201830060972.9.
TIPO; Notice of Allowance dated Jun. 12, 2014 in Application No. 98117513.
TIPO; Notice of Allowance dated Feb. 24, 2016 in Application No. 99110511.
TIPO; Notice of Allowance dated Apr. 28, 2015 in Application No. 99114330.
TIPO; Notice of Allowance dated Oct. 16, 2015 in Application No. 99114331.
TIPO; Notice of Allowance dated Mar. 14, 2016 in Application No. 99127063.
TIPO; Notice of Allowance dated Jun. 29, 2016 in Application No. 100113130.
TIPO; Notice of Allowance dated Oct. 14, 2015 in Application No. 100130472.
TIPO; Notice of Allowance dated Oct. 19, 2016 in Application No. 101124745.
TIPO; Notice of Allowance dated Nov. 2, 2016 in Application No. 101142581.
TIPO; Notice of Allowance dated Sep. 9, 2016 in Application No. 101142582.
TIPO; Notice of Allowance dated Feb. 13, 2017 in Application No. 102113028.
TIPO; Notice of Allowance dated Dec. 26, 2017 in Application No. 102115605.
TIPO; Notice of Allowance dated May 3, 2017 in Application No. 102129262.
TIPO; Notice of Allowance dated Aug. 24, 2018 in Application No. 102126071.
TIPO; Notice of Allowance dated Jul. 18, 2017 in Application No. 102127065.
TIPO; Notice of Allowance dated Aug. 29, 2017 in Application No. 102129397.
TIPO; Notice of Allowance dated Jan. 26, 2017 in Application No. 102131839.
TIPO; Notice of Allowance dated Apr. 19, 2017 in Application No. 102132952.
TIPO; Notice of Allowance dated Jan. 24, 2018 in Application No. 103101400.
TIPO; Notice of Allowance dated Nov. 30, 2017 in Application No. 103102563.
TIPO; Notice of Allowance dated Oct. 20, 2017 in Application No. 103105251.
TIPO; Notice of Allowance dated Apr. 10, 2018 in Application No. 103106021.
TIPO; Notice of Allowance dated Apr. 10, 2018 in Application No. 103106022.
TIPO; Notice of Allowance dated Jan. 22, 2018 in Application No. 103117477.
TIPO; Notice of Allowance dated Mar. 13, 2018 in Application No. 103117478.
TIPO; Notice of Allowance dated Sep. 25, 2017 in Application No. 103120478.
TIPO; Office Action dated Sep. 20, 2018 in Application No. 103123439.

(56)

References Cited

OTHER PUBLICATIONS

- TIPO; Office Action dated Apr. 25, 2018 in Application No. 103124509.
- TIPO; Notice of Allowance dated Jun. 19, 2018 in Application No. 103127588.
- TIPO; Notice of Allowance dated Dec. 11, 2017 in Application No. 103127734.
- TIPO; Notice of Allowance dated Apr. 19, 2018 in Application No. 103134537.
- TIPO; Notice of Allowance dated Oct. 17, 2017 in Application No. 103136251.
- TIPO; Notice of Allowance dated Jun. 13, 2018 in Application No. 103138510.
- TIPO; Notice of Allowance dated Sep. 11, 2018 in Application No. 103139014.
- TIPO; Notice of Allowance dated Sep. 18, 2018 in Application No. 104111910.
- TIPO; Notice of Allowance dated Dec. 5, 2017 in Application No. 105308015.
- TIPO; Notice of Allowance dated Jun. 5, 2018 in Application No. 106117181.
- TIPO; Office Action dated Sep. 28, 2018 in Application No. 106119537.
- TIPO; Office Action dated Aug. 31, 2018 in Application No. 106138119.
- TIPO; Office Action dated Oct. 3, 2018 in Application No. 106142731.
- TIPO; Office Action dated Sep. 28, 2018 in Application No. 107112951.
- TIPO; Notice of Allowance dated Aug. 29, 2018 in Application No. 107300633.
- TIPO; Notice of Allowance dated Apr. 11, 2018 in Application No. 105308015D01.
- USPTO; Non-Final Office Action dated Feb. 15, 2012 in U.S. Appl. No. 13/085,531.
- USPTO; Notice of Allowance dated Jul. 12, 2012 in U.S. Appl. No. 13/085,531.
- USPTO; Final Office Action dated Nov. 2, 2018 in U.S. Appl. No. 13/169,951.
- USPTO; Final Office Action dated Nov. 1, 2018 in U.S. Appl. No. 14/219,839.
- USPTO; Final Office Action dated Nov. 2, 2018 in U.S. Appl. No. 14/219,879.
- USPTO; Final Office Action dated Nov. 28, 2018 in U.S. Appl. No. 14/508,489.
- USPTO; Notice of Allowance dated Nov. 19, 2018 in U.S. Appl. No. 14/656,588.
- USPTO; Notice of Allowance dated Nov. 19, 2018 in U.S. Appl. No. 14/919,536.
- USPTO; Final Office Action dated Dec. 10, 2018 in U.S. Appl. No. 14/997,683.
- USPTO; Final Office Action dated Oct. 19, 2018 in U.S. Appl. No. 15/060,412.
- USPTO; Non-Final Office Action dated Sep. 26, 2018 in U.S. Appl. No. 15/074,813.
- USPTO; Non-Final Office Action dated Nov. 23, 2018 in U.S. Appl. No. 15/135,258.
- USPTO; Non-Final Office Action dated Oct. 9, 2018 in U.S. Appl. No. 15/182,504.
- USPTO; Final Office Action dated Oct. 9, 2018 in U.S. Appl. No. 15/205,827.
- USPTO; Non-Final Office Action dated Nov. 14, 2018 in U.S. Appl. No. 15/377,439.
- USPTO; Notice of Allowance dated Nov. 14, 2018 in U.S. Appl. No. 15/388,410.
- USPTO; Notice of Allowance dated Dec. 28, 2018 in U.S. Appl. No. 15/388,410.
- USPTO; Restriction Requirement dated Dec. 5, 2018 in U.S. Appl. No. 15/402,993.
- USPTO; Advisory Action dated Dec. 4, 2018 in U.S. Appl. No. 15/434,051.
- USPTO; Notice of Allowance dated Nov. 30, 2018 in U.S. Appl. No. 15/472,750.
- USPTO; Notice of Allowance dated Nov. 1, 2018 in U.S. Appl. No. 15/499,647.
- USPTO; Notice of Allowance dated Nov. 15, 2018 in U.S. Appl. No. 15/499,647.
- USPTO; Final Office Action dated Nov. 16, 2018 in U.S. Appl. No. 15/592,730.
- USPTO; Restriction Requirement dated Oct. 10, 2018 in U.S. Appl. No. 15/615,489.
- USPTO; Non-Final Office Action dated Nov. 9, 2018 in U.S. Appl. No. 15/636,307.
- USPTO; Final Office Action dated Nov. 20, 2018 in U.S. Appl. No. 15/650,686.
- USPTO; Non-Final Office Action dated Dec. 4, 2018 in U.S. Appl. No. 15/672,063.
- USPTO; Restriction Requirement dated Oct. 15, 2018 in U.S. Appl. No. 15/672,119.
- USPTO; Advisory Action dated Nov. 26, 2018 in U.S. Appl. No. 15/683,701.
- USPTO; Non-Final Office Action dated Dec. 18, 2018 in U.S. Appl. No. 15/690,017.
- USPTO; Non-Final Office Action dated Dec. 6, 2018 in U.S. Appl. No. 15/705,955.
- USPTO; Notice of Allowance dated Dec. 6, 2018 in U.S. Appl. No. 15/711,989.
- USPTO; Final Office Action dated Dec. 13, 2018 in U.S. Appl. No. 15/719,208.
- USPTO; Final Office Action dated Nov. 14, 2018 in U.S. Appl. No. 15/726,959.
- USPTO; Non-Final Office Action dated Nov. 28, 2018 in U.S. Appl. No. 15/795,056.
- USPTO; Notice-Final Office Action dated Sep. 26, 2018 in U.S. Appl. No. 15/832,188.
- USPTO; Notice of Allowance dated Dec. 10, 2018 in U.S. Appl. No. 15/863,340.
- USPTO; Restriction Requirement dated Dec. 13, 2018 in U.S. Appl. No. 15/886,225.
- USPTO; Notice-Final Office Action dated Nov. 15, 2018 in U.S. Appl. No. 15/890,037.
- USPTO; Restriction Requirement dated Oct. 9, 2018 in U.S. Appl. No. 15/892,756.
- USPTO; Restriction Requirement dated Nov. 26, 2018 in U.S. Appl. No. 15/917,262.
- USPTO; Restriction Requirement dated Nov. 2, 2018 in U.S. Appl. No. 16/018,692.
- WIPO; International Search Report and Written Opinion dated Nov. 6, 2018 in Application No. PCT/IB2017/001652.
- Beynet et al. "Low temperature plasma-enhanced ALD enables cost-effective spacer defined double patterning." Proceedings of SPIE, 7520, (2009).
- Gupta et al., "Charge carrier transport and electroluminescence in atomic layer deposited poly-GaN/c-Si heterojunction diodes," Journal of Applied Physics, 124, 084503 (2018).
- MacKenzie et al. "Stress Control of Si-Based PEVCD Dielectrics," Proc. Symp. Silicon Nitride and Silicon Dioxide Thin Insulating Films & Other Emerging Dielectrics VIII, 148-159 (2005).
- USPTO; Notice of Allowance dated Jun. 28, 2017 in U.S. Appl. No. 13/166,367.
- USPTO; Non-Final Office Action dated Sep. 20, 2018 in U.S. Appl. No. 13/651,144.
- USPTO; Notice of Allowance dated Aug. 13, 2018 in U.S. Appl. No. 13/941,226.
- USPTO; Notice of Allowance dated Oct. 3, 2018 in U.S. Appl. No. 13/941,226.
- USPTO; Notice of Allowance dated Aug. 29, 2018 in U.S. Appl. No. 14/090,750.
- USPTO; Notice of Allowance dated Sep. 24, 2018 in U.S. Appl. No. 14/218,690.
- USPTO; Final Office Action dated Sep. 5, 2018 in U.S. Appl. No. 14/752,712.
- USPTO; Advisory Action dated Aug. 10, 2018 in U.S. Appl. No. 14/829,565.

(56)

References Cited

OTHER PUBLICATIONS

- USPTO; Non-Final Office Action dated Sep. 6, 2018 in U.S. Appl. No. 14/829,565.
- USPTO; Notice of Allowance dated Oct. 20, 2017 in U.S. Appl. No. 14/884,695.
- USPTO; Notice of Allowance dated Oct. 4, 2018 in U.S. Appl. No. 14/919,536.
- USPTO; Non-Final Office Action dated Aug. 27, 2018 in U.S. Appl. No. 15/067,028.
- USPTO; Notice of Allowance dated Oct. 14, 2018 in U.S. Appl. No. 15/135,333.
- USPTO; Notice of Allowance dated May 22, 2017 in U.S. Appl. No. 15/222,738.
- USPTO; Notice of Allowance dated Sep. 10, 2018 in U.S. Appl. No. 15/222,749.
- USPTO; Non-Final Office Action dated Oct. 1, 2018 in U.S. Appl. No. 15/222,780.
- USPTO; Non-Final Office Action dated Sep. 13, 2018 in U.S. Appl. No. 15/262,990.
- USPTO; Non-Final Office Action dated Oct. 3, 2017 in U.S. Appl. No. 15/388,410.
- USPTO; Non-Final Office Action dated Sep. 20, 2018 in U.S. Appl. No. 15/410,503.
- USPTO; Final Office Action dated Aug. 29, 2018 in U.S. Appl. No. 15/434,051.
- USPTO; Non-Final Office Action dated Sep. 10, 2018 in U.S. Appl. No. 15/489,453.
- USPTO; Notice of Allowance dated Jul. 18, 2018 in U.S. Appl. No. 15/640,239.
- USPTO; Notice of Allowance dated Aug. 30, 2018 in U.S. Appl. No. 15/640,239.
- USPTO; Non-Final Office Action dated Sep. 21, 2017 in U.S. Appl. No. 15/659,631.
- USPTO; Non-Final Office Action dated Aug. 27, 2018 in U.S. Appl. No. 15/662,107.
- USPTO; Requirement for Restriction dated Sep. 11, 2018 in U.S. Appl. No. 15/672,063.
- USPTO; Requirement for Restriction dated Aug. 14, 2018 in U.S. Appl. No. 15/705,955.
- USPTO; Non-Final Office Action dated Oct. 4, 2018 in U.S. Appl. No. 15/726,222.
- USPTO; Restriction Requirement dated Aug. 31, 2018 in U.S. Appl. No. 15/795,056.
- USPTO; Non-Final Office Action dated Jun. 26, 2018 in U.S. Appl. No. 15/796,693.
- USPTO; Non-Final Office Action dated Sep. 10, 2018 in U.S. Appl. No. 15/836,547.
- European Patent Office; Office Action dated Aug. 10, 2018 in Application No. 09767208.3.
- Korean Patent Office; Office Action dated Apr. 2, 2018 in Application No. 10-2011-0036449.
- Korean Patent Office; Office Action dated Sep. 18, 2018 in Application No. 10-2012-0064526.
- Korean Patent Office; Office Action dated Sep. 27, 2018 in Application No. 10-2012-0076564.
- Korean Patent Office; Office Action dated Sep. 28, 2017 in Application No. 10-2017-7023740.
- Taiwanese Patent Office; Office Action dated Sep. 26, 2018 in Application No. 103132230.
- Taiwanese Patent Office; Office Action dated May 21, 2018 in Application No. 103139014.
- Taiwanese Patent Office; Office Action dated Sep. 9, 2018 in Application No. 104107876.
- Taiwanese Patent Office; Office Action dated Aug. 7, 2018 in Application No. 104107888.
- Taiwanese Patent Office; Office Action dated Jul. 9, 2018 in Application No. 104110326.
- Taiwanese Patent Office; Office Action dated Jul. 11, 2018 in Application No. 104124377.
- Taiwanese Patent Office; Office Action dated Jun. 25, 2018 in Application No. 106138800.
- Taiwanese Patent Office; Office Action dated Aug. 31, 2018 in Application No. 10720809210.
- WIPO; International Search Report and Written Opinion dated Jul. 9, 2018 in Application No. PCT/IB2018/000419.
- WIPO; International Search Report and Written Opinion dated Sep. 14, 2018 in Application No. PCT/IB2017/001640.
- Crystal IS "Application Note: Using UV Reflective Materials to Maximize Disinfection"; AN011; Jun. 16, 2016.
- Kukli et al., "Properties of hafnium oxide films grown by atomic layer deposition from hafnium tetraiodide and oxygen". *Journal of Applied Physicas*, vol. 92, No. 10, Nov. 15, 2002, pp. 5698-5703.
- Liang et al. "Conversion of Metal Carbides to Carbide Derived Carbon by Reactive Ion Etching in Halogen Gas" *Micro (MEMS) and Nanotechnologies for Space Applications*, Thomas George et al. vol. 6223, 2006 p. 62230J-I to 62230J-11 lines 3-14 in the "Abstract" section and lines 7-9 in the "Introduction" section of p. 1, lines 3-4 in the "Introduction" section and lines 3-4 in the "Experimental Procedure" section of p. 2.
- Sellers, Making Your Own Timber Dogs, Paul Sellers blog, Published on Nov. 18, 2014, [online], [site visited Jun. 10, 2017]. Available from Internet, <URL: <https://paulsellers.com/2014/11/making-your-own-timber-dogs/>.
- "Polyurethane HF"; webpage; no date. Cited in Notice of References dated May 18, 2017 in U.S. Appl. No. 14/884,695.
- Xu et al., "14NM Metal Gate Film Stack Development and Challenges," SMIC et al. (2016)
- USPTO; Office Action dated Aug. 27, 2010 in U.S. Appl. No. 12/118,596.
- USPTO; Office Action dated Feb. 15, 2011 in U.S. Appl. No. 12/118,596.
- USPTO; Notice of Allowance dated Aug. 4, 2011 in U.S. Appl. No. 12/118,596.
- USPTO; Non-Final Office Action dated Apr. 1, 2010 in U.S. Appl. No. 12/357,174.
- USPTO; Final Office Action dated Sep. 1, 2010 in U.S. Appl. No. 12/357,174.
- USPTO; Notice of Allowance dated Dec. 13, 2010 in U.S. Appl. No. 12/357,174.
- USPTO; Non-Final Office Action dated Dec. 29, 2010 in U.S. Appl. No. 12/362,023.
- USPTO; Non-Final Office Action dated Jul. 26, 2011 in U.S. Appl. No. 12/416,809.
- USPTO; Final Office Action dated Dec. 6, 2011 in U.S. Appl. No. 12/416,809.
- USPTO; Notice of Allowance dated Jun. 16, 2011 in U.S. Appl. No. 12/430,751.
- USPTO; Notice of Allowance dated Jul. 27, 2011 in U.S. Appl. No. 12/430,751.
- USPTO; Notice of Allowance dated Oct. 1, 2010 in U.S. Appl. No. 12/467,017.
- USPTO; Non-Final Office Action dated Mar. 18, 2010 in U.S. Appl. No. 12/489,252.
- USPTO; Notice of Allowance dated Sep. 2, 2010 in U.S. Appl. No. 12/489,252.
- USPTO; Non-Final Office Action dated Dec. 15, 2010 in U.S. Appl. No. 12/553,759.
- USPTO; Final Office Action dated May 4, 2011 in U.S. Appl. No. 12/553,759.
- USPTO; Non-Final Office Action dated Sep. 6, 2011 in U.S. Appl. No. 12/553,759.
- USPTO; Notice of Allowance dated Jan. 24, 2012 in U.S. Appl. No. 12/553,759.
- USPTO; Non-Final Office Action dated Oct. 19, 2012 in U.S. Appl. No. 12/618,355.
- USPTO; Final Office Action dated May 8, 2013 in U.S. Appl. No. 12/618,355.
- USPTO; Non-Final Office Action dated Apr. 8, 2015 in U.S. Appl. No. 12/618,355.
- USPTO; Final Office Action dated Oct. 22, 2015 in U.S. Appl. No. 12/618,355.

(56)

References Cited

OTHER PUBLICATIONS

- USPTO; Non-Final Office Action dated Jun. 30, 2016 in U.S. Appl. No. 12/618,355.
- USPTO; Final Office Action dated Feb. 10, 2017 in U.S. Appl. No. 12/618,355.
- USPTO; Non-Final Office Action dated Feb. 16, 2012 in U.S. Appl. No. 12/618,419.
- USPTO; Final Office Action dated Jun. 22, 2012 in U.S. Appl. No. 12/618,419.
- USPTO; Non-Final Office Action dated Nov. 27, 2012 in U.S. Appl. No. 12/618,419.
- USPTO; Notice of Allowance dated Apr. 12, 2013 in U.S. Appl. No. 12/618,419.
- USPTO; Non-Final Office Action dated Dec. 6, 2011 in U.S. Appl. No. 12/718,731.
- USPTO; Notice of Allowance dated Mar. 16, 2012 in U.S. Appl. No. 12/718,731.
- USPTO; Restriction Requirement dated Jan. 15, 2013 in U.S. Appl. No. 12/754,223.
- USPTO; Office Action dated Feb. 26, 2013 in U.S. Appl. No. 12/754,223.
- USPTO; Final Office Action dated Jun. 28, 2013 in U.S. Appl. No. 12/754,223.
- USPTO; Office Action dated Feb. 25, 2014 in U.S. Appl. No. 12/754,223.
- USPTO; Final Office Action dated Jul. 14, 2014 in U.S. Appl. No. 12/754,223.
- USPTO; Non-Final Office Action dated Mar. 25, 2015 in U.S. Appl. No. 12/754,223.
- USPTO; Final Office Action dated Aug. 12, 2015 in U.S. Appl. No. 12/754,223.
- USPTO; Notice of Allowance dated May 23, 2016 in U.S. Appl. No. 12/754,223.
- USPTO; Office Action dated Apr. 23, 2013 in U.S. Appl. No. 12/763,037.
- USPTO; Final Office Action dated Oct. 21, 2013 in U.S. Appl. No. 12/763,037.
- USPTO; Office Action dated Oct. 8, 2014 in U.S. Appl. No. 12/763,037.
- USPTO; Notice of Allowance dated Jan. 27, 2015 in U.S. Appl. No. 12/763,037.
- USPTO; Non-Final Office Action dated Jan. 24, 2011 in U.S. Appl. No. 12/778,808.
- USPTO; Notice of Allowance dated May 9, 2011 in U.S. Appl. No. 12/778,808.
- USPTO; Notice of Allowance dated Oct. 12, 2012 in U.S. Appl. No. 12/832,739.
- USPTO; Non-Final Office Action dated Oct. 16, 2012 in U.S. Appl. No. 12/847,848.
- USPTO; Final Office Action dated Apr. 22, 2013 in U.S. Appl. No. 12/847,848.
- USPTO; Notice of Allowance dated Jan. 16, 2014 in U.S. Appl. No. 12/847,848.
- USPTO; Restriction Requirement dated Sep. 25, 2012 in U.S. Appl. No. 12/854,818.
- USPTO; Office Action dated Dec. 6, 2012 in U.S. Appl. No. 12/854,818.
- USPTO; Final Office Action dated Mar. 13, 2013 in U.S. Appl. No. 12/854,818.
- USPTO; Office Action dated Aug. 30, 2013 in U.S. Appl. No. 12/854,818.
- USPTO; Final Office Action dated Mar. 26, 2014 in U.S. Appl. No. 12/854,818.
- USPTO; Office Action dated Jun. 3, 2014 in U.S. Appl. No. 12/854,818.
- USPTO; Non-Final Office Action dated Jul. 11, 2012 in U.S. Appl. No. 12/875,889.
- USPTO; Notice of Allowance dated Jan. 4, 2013 in U.S. Appl. No. 12/875,889.
- USPTO; Notice of Allowance dated Jan. 9, 2012 in U.S. Appl. No. 12/901,323.
- USPTO; Non-Final Office Action dated Nov. 20, 2013 in U.S. Appl. No. 12/910,607.
- USPTO; Final Office Action dated Apr. 28, 2014 in U.S. Appl. No. 12/910,607.
- USPTO; Notice of Allowance dated Aug. 15, 2014 in U.S. Appl. No. 12/910,607.
- USPTO; Non-Final Office Action dated Oct. 24, 2012 in U.S. Appl. No. 12/940,906.
- USPTO; Final Office Action dated Feb. 13, 2013 in U.S. Appl. No. 12/940,906.
- USPTO; Notice of Allowance dated Apr. 23, 2013 in U.S. Appl. No. 12/940,906.
- USPTO; Non-Final Office Action dated Dec. 7, 2012 in U.S. Appl. No. 12/953,870.
- USPTO; Final Office Action dated Apr. 22, 2013 in U.S. Appl. No. 12/953,870.
- USPTO; Non-Final Office Action dated Sep. 19, 2012 in U.S. Appl. No. 13/016,735.
- USPTO; Final Office Action dated Feb. 11, 2013 in U.S. Appl. No. 13/016,735.
- USPTO; Notice of Allowance dated Apr. 24, 2013 in U.S. Appl. No. 13/016,735.
- USPTO; Non-Final Office Action dated Apr. 4, 2012 in U.S. Appl. No. 13/030,438.
- USPTO; Final Office Action dated Aug. 22, 2012 in U.S. Appl. No. 13/030,438.
- USPTO; Notice of Allowance dated Oct. 24, 2012 in U.S. Appl. No. 13/030,438.
- USPTO; Non-Final Office Action dated Dec. 3, 2012 in U.S. Appl. No. 13/040,013.
- USPTO; Notice of Allowance dated May 3, 2013 in U.S. Appl. No. 13/040,013.
- USPTO; Notice of Allowance dated Sep. 13, 2012 in U.S. Appl. No. 13/085,698.
- USPTO; Non-Final Office Action dated Mar. 29, 2013 in U.S. Appl. No. 13/094,402.
- USPTO; Final Office Action dated Jul. 17, 2013 in U.S. Appl. No. 13/094,402.
- USPTO; Notice of Allowance dated Sep. 30, 2013 in U.S. Appl. No. 13/094,402.
- USPTO; Restriction Requirement dated May 8, 2013 in U.S. Appl. No. 13/102,980.
- USPTO; Office Action dated Oct. 7, 2013 in U.S. Appl. No. 13/102,980.
- USPTO; Final Office Action dated Mar. 25, 2014 in U.S. Appl. No. 13/102,980.
- USPTO; Notice of Allowance dated Jul. 3, 2014 in U.S. Appl. No. 13/102,980.
- USPTO; Non-Final Office Action dated Jul. 17, 2014 in U.S. Appl. No. 13/154,271.
- USPTO; Final Office Action dated Jan. 2, 2015 in U.S. Appl. No. 13/154,271.
- USPTO; Non-Final Office Action dated May 27, 2015 in U.S. Appl. No. 13/154,271.
- USPTO; Final Office Action dated Nov. 23, 2015 in U.S. Appl. No. 13/154,271.
- USPTO; Notice of Allowance dated Feb. 10, 2016 in U.S. Appl. No. 13/154,271.
- USPTO; Non-Final Office Action dated Jun. 27, 2016 in U.S. Appl. No. 13/166,367.
- USPTO; Final Office Action dated Dec. 30, 2016 in U.S. Appl. No. 13/166,367.
- USPTO; Non-Final Office Action dated Oct. 27, 2014 in U.S. Appl. No. 13/169,951.
- USPTO; Final Office Action dated May 26, 2015 in U.S. Appl. No. 13/169,951.
- USPTO; Non-Final Office Action dated Sep. 1, 2015 in U.S. Appl. No. 13/169,951.
- USPTO; Final Office Action dated Mar. 3, 2016 in U.S. Appl. No. 13/169,951.

(56)

References Cited

OTHER PUBLICATIONS

- USPTO; Non-Final Office Action dated Jun. 9, 2016 in U.S. Appl. No. 13/169,951.
- USPTO; Final Office Action dated Dec. 9, 2016 in U.S. Appl. No. 13/169,951.
- USPTO; Non-Final Office Action dated Apr. 26, 2017 in U.S. Appl. No. 13/169,951.
- USPTO; Final Office Action dated 13/169,951 in U.S. Appl. No. 13/169,951.
- USPTO; Non-Final Office Action dated Jun. 24, 2014 in U.S. Appl. No. 13/181,407.
- USPTO; Final Office Action dated Sep. 24, 2014 in U.S. Appl. No. 13/181,407.
- USPTO; Non-Final Office Action dated Jan. 2, 2015 in U.S. Appl. No. 13/181,407.
- USPTO; Final Office Action dated Apr. 8, 2015 in U.S. Appl. No. 13/181,407.
- USPTO; Non-Final Office Action dated Jan. 23, 2013 in U.S. Appl. No. 13/184,351.
- USPTO; Final Office Action dated Jul. 29, 2013 in U.S. Appl. No. 13/184,351.
- USPTO; Non-Final Office Action dated Jul. 16, 2014 in U.S. Appl. No. 13/184,351.
- USPTO; Final Office Action dated Feb. 17, 2015 in U.S. Appl. No. 13/184,351.
- USPTO; Non-Final Office Action dated Aug. 10, 2015 in U.S. Appl. No. 13/184,351.
- USPTO; Final Office Action dated Feb. 12, 2016 in U.S. Appl. No. 13/184,351.
- USPTO; Non-Final Office Action dated Dec. 15, 2016 in U.S. Appl. No. 13/184,351.
- USPTO; Final Office Action dated Jun. 15, 2017 in U.S. Appl. No. 13/184,351.
- USPTO; Non-Final Office Action dated Sep. 17, 2014 in U.S. Appl. No. 13/187,300.
- USPTO; Final Office Action dated Apr. 15, 2015 in U.S. Appl. No. 13/187,300.
- USPTO; Non-Final Office Action dated Apr. 7, 2016 in U.S. Appl. No. 13/187,300.
- USPTO; Final Office Acton dated Sep. 23, 2016 in U.S. Appl. No. 13/187,300.
- USPTO; Non-Final Office Action dated Jan. 30, 2017 in U.S. Appl. No. 13/187,300.
- USPTO; Final Office Action dated Aug. 9, 2017 in U.S. Appl. No. 13/187,300.
- USPTO; Non-Final Office Action dated Oct. 1, 2012 in U.S. Appl. No. 13/191,762.
- USPTO; Final Office Action dated Apr. 10, 2013 in U.S. Appl. No. 13/191,762.
- USPTO; Notice of Allowance dated Aug. 15, 2013 in U.S. Appl. No. 13/191,762.
- USPTO; Non-Final Office Action dated Oct. 22, 2012 in U.S. Appl. No. 13/238,960.
- USPTO; Final Office Action dated May 3, 2013 in U.S. Appl. No. 13/238,960.
- USPTO; Non-Final Office Action dated Apr. 26, 2013 in U.S. Appl. No. 13/250,721.
- USPTO; Notice of Allowance dated Sep. 11, 2013 in U.S. Appl. No. 13/250,721.
- USPTO; Non-Final Office Action dated Jul. 2, 2014 in U.S. Appl. No. 13/283,408.
- USPTO; Final Office Action dated Jan. 29, 2015 in U.S. Appl. No. 13/283,408.
- USPTO; Non-Final Office Action dated Jun. 17, 2015 in U.S. Appl. No. 13/283,408.
- USPTO; Final Office Action dated Dec. 18, 2015 in U.S. Appl. No. 13/283,408.
- USPTO; Notice of Allowance dated Mar. 28, 2016 in U.S. Appl. No. 13/283,408.
- USPTO; Restriction Requirement dated Dec. 16, 2013 in U.S. Appl. No. 13/284,642.
- USPTO; Restriction Requirement dated Apr. 21, 2014 in U.S. Appl. No. 13/284,642.
- USPTO; Office Action dated Jul. 30, 2014 in U.S. Appl. No. 13/284,642.
- USPTO; Notice of Allowance dated Feb. 11, 2015 in U.S. Appl. No. 13/284,642.
- USPTO; Office Action dated Jan. 28, 2014 in U.S. Appl. No. 13/312,591.
- USPTO; Final Office Action dated May 14, 2014 in U.S. Appl. No. 13/312,591.
- USPTO; Non-Final Office Action dated Nov. 26, 2014 in U.S. Appl. No. 13/312,591.
- USPTO; Final Office Action dated Mar. 20, 2015 in U.S. Appl. No. 13/312,591.
- USPTO; Notice of Allowance dated May 14, 2015 in U.S. Appl. No. 13/312,591.
- USPTO; Non-Final Office Action dated Apr. 9, 2014 in U.S. Appl. No. 13/333,420.
- USPTO; Notice of Allowance dated Sep. 15, 2014 in U.S. Appl. No. 13/333,420.
- USPTO; Office Action dated Jan. 10, 2013 in U.S. Appl. No. 13/339,609.
- USPTO; Office Action dated Feb. 11, 2013 in U.S. Appl. No. 13/339,609.
- USPTO; Final Office Action dated May 17, 2013 in U.S. Appl. No. 13/339,609.
- USPTO; Office Action dated Aug. 29, 2013 in U.S. Appl. No. 13/339,609.
- USPTO; Final Office Action dated Dec. 18, 2013 in U.S. Appl. No. 13/339,609.
- USPTO; Notice of Allowance dated Apr. 7, 2014 in U.S. Appl. No. 13/339,609.
- USPTO; Non-Final Office Action dated Oct. 10, 2012 in U.S. Appl. No. 13/406,791.
- USPTO; Final Office Action dated Jan. 31, 2013 in U.S. Appl. No. 13/406,791.
- USPTO; Non-Final Office Action dated Apr. 25, 2013 in U.S. Appl. No. 13/406,791.
- USPTO; Final Office Action dated Aug. 23, 2013 in U.S. Appl. No. 13/406,791.
- USPTO; Non-Final Office Action dated Dec. 4, 2013 in U.S. Appl. No. 13/406,791.
- USPTO; Final Office Action dated Apr. 21, 2014 in U.S. Appl. No. 13/406,791.
- USPTO; Non-Final Office Action dated Jan. 14, 2013 in U.S. Appl. No. 13/410,970.
- USPTO; Notice of Allowance dated Feb. 14, 2013 in U.S. Appl. No. 13/410,970.
- USPTO; Non-Final Office Action dated Feb. 13, 2014 in U.S. Appl. No. 13/411,271.
- USPTO; Non-Final Office Action dated Jul. 31, 2014 in U.S. Appl. No. 13/411,271.
- USPTO; Final Office Action dated Jan. 16, 2015 in U.S. Appl. No. 13/411,271.
- USPTO; Notice of Allowance dated Oct. 6, 2015 in U.S. Appl. No. 13/411,271.
- USPTO; Restriction Requirement dated Oct. 29, 2013 in U.S. Appl. No. 13/439,528.
- USPTO; Office Action dated Feb. 4, 2014 in U.S. Appl. No. 13/439,528.
- USPTO; Final Office Action dated Jul. 8, 2014 in U.S. Appl. No. 13/439,528.
- USPTO; Notice of Allowance dated Oct. 21, 2014 in U.S. Appl. No. 13/439,528.
- USPTO; Non-Final Office Action dated Apr. 11, 2013 in U.S. Appl. No. 13/450,368.
- USPTO; Notice of Allowance dated Jul. 17, 2013 in U.S. Appl. No. 13/450,368.
- USPTO; Office Action dated May 23, 2013 in U.S. Appl. No. 13/465,340.

(56)

References Cited

OTHER PUBLICATIONS

- USPTO; Final Office Action dated Oct. 30, 2013 in U.S. Appl. No. 13/465,340.
- USPTO; Notice of Allowance dated Feb. 12, 2014 in U.S. Appl. No. 13/465,340.
- USPTO; Non-Final Office Action dated Oct. 17, 2013 in U.S. Appl. No. 13/493,897.
- USPTO; Notice of Allowance dated Mar. 20, 2014 in U.S. Appl. No. 13/493,897.
- USPTO; Office Action dated Dec. 20, 2013 in U.S. Appl. No. 13/535,214.
- USPTO; Final Office Action dated Jun. 18, 2014 in U.S. Appl. No. 13/535,214.
- USPTO; Notice of Allowance dated Oct. 23, 2014 in U.S. Appl. No. 13/535,214.
- USPTO; Non-Final Office Action dated Sep. 11, 2013 in U.S. Appl. No. 13/550,419.
- USPTO; Final Office Action dated Jan. 27, 2014 in U.S. Appl. No. 13/550,419.
- USPTO; Notice of Allowance dated May 29, 2014 in U.S. Appl. No. 13/550,419.
- USPTO; Non-Final Office Action dated Aug. 8, 2014 in U.S. Appl. No. 13/563,066.
- USPTO; Final Office Action dated Feb. 12, 2015 in U.S. Appl. No. 13/563,066.
- USPTO; Notice of Allowance dated Jun. 12, 2015 in U.S. Appl. No. 13/563,066.
- USPTO; Notice of Allowance dated Jul. 16, 2015 in U.S. Appl. No. 13/563,066.
- USPTO; Non-Final Office Action dated Nov. 7, 2013 in U.S. Appl. No. 13/565,564.
- USPTO; Final Office Action dated Feb. 28, 2014 in U.S. Appl. No. 13/565,564.
- USPTO; Non-Final Office Action dated Jul. 2, 2014 in U.S. Appl. No. 13/565,564.
- USPTO; Notice of Allowance dated Nov. 3, 2014 in U.S. Appl. No. 13/565,564.
- USPTO; Non-Final Office Action dated Aug. 30, 2013 in U.S. Appl. No. 13/570,067.
- USPTO; Notice of Allowance dated Jan. 6, 2014 in U.S. Appl. No. 13/570,067.
- USPTO; Non-Final Office Action dated Oct. 15, 2014 in U.S. Appl. No. 13/597,043.
- USPTO; Final Office Action dated Mar. 13, 2015 in U.S. Appl. No. 13/597,043.
- USPTO; Notice of Allowance dated Aug. 28, 2015 in U.S. Appl. No. 13/597,043.
- USPTO; Non-Final Office Action dated Feb. 12, 2015 in U.S. Appl. No. 13/597,108.
- USPTO; Final Office Action dated Jun. 1, 2015 in U.S. Appl. No. 13/597,108.
- USPTO; Non-Final Office Action dated Dec. 8, 2015 in U.S. Appl. No. 13/597,108.
- USPTO; Final Office Action dated Jun. 2, 2016 in U.S. Appl. No. 13/597,108.
- USPTO; Non-Final Office Action dated Sep. 15, 2016 in U.S. Appl. No. 13/597,108.
- USPTO; Notice of Allowance dated Mar. 27, 2014 in U.S. Appl. No. 13/604,498.
- USPTO; Office Action dated Nov. 15, 2013 in U.S. Appl. No. 13/612,538.
- USPTO; Office Action dated Jul. 10, 2014 in U.S. Appl. No. 13/612,538.
- USPTO; Non-Final Office Action dated Apr. 15, 2015 in U.S. Appl. No. 13/646,403.
- USPTO; Final Office Action dated Oct. 15, 2015 in U.S. Appl. No. 13/646,403.
- USPTO; Notice of Allowance dated Feb. 2, 2016 in U.S. Appl. No. 13/646,403.
- USPTO; Non-Final Office Action dated May 15, 2014 in U.S. Appl. No. 13/646,471.
- USPTO; Final Office Action dated Aug. 18, 2014 in U.S. Appl. No. 13/646,471.
- USPTO; Non-Final Office Action dated Dec. 16, 2014 in U.S. Appl. No. 13/646,471.
- USPTO; Final Office Action dated Apr. 21, 2015 in U.S. Appl. No. 13/646,471.
- USPTO; Non-Final Office Action dated Aug. 19, 2015 in U.S. Appl. No. 13/646,471.
- USPTO; Final Office Action dated Jan. 22, 2016 in U.S. Appl. No. 13/646,471.
- USPTO; Non-Final Office Action dated Jun. 2, 2016 in U.S. Appl. No. 13/646,471.
- USPTO; Non-Final Office Action dated May 28, 2015 in U.S. Appl. No. 13/651,144.
- USPTO; Final Office Action dated Sep. 30, 2016 in U.S. Appl. No. 14/808,979.
- USPTO; Final Office Action dated Nov. 19, 2015 in U.S. Appl. No. 13/651,144.
- USPTO; Non-Final Office Action dated May 10, 2016 in U.S. Appl. No. 13/651,144.
- USPTO; Final Office Action dated Sep. 20, 2016 in U.S. Appl. No. 13/651,144.
- USPTO; Non-Final Office Action dated May 17, 2017 in U.S. Appl. No. 13/651,144.
- USPTO; Final Office Action dated Dec. 14, 2017 in U.S. Appl. No. 13/651,144.
- USPTO; Non-Final Office Action dated Nov. 19, 2015 in U.S. Appl. No. 14/659,437.
- USPTO; Final Office Action dated Mar. 17, 2016 in U.S. Appl. No. 14/659,437.
- USPTO; Notice of Allowance dated May 31, 2016 in U.S. Appl. No. 14/659,437.
- USPTO; Non-Final Office Action dated Jun. 18, 2015 in U.S. Appl. No. 13/665,366.
- USPTO; Non-Final Office Action dated Apr. 3, 2015 in U.S. Appl. No. 13/677,133.
- USPTO; Notice of Allowance dated Aug. 4, 2015 in U.S. Appl. No. 13/677,133.
- USPTO; Office Action dated Jun. 2, 2014 in U.S. Appl. No. 13/677,151.
- USPTO; Final Office Action dated Nov. 14, 2014 in U.S. Appl. No. 13/677,151.
- USPTO; Notice of Allowance dated Feb. 26, 2015 in U.S. Appl. No. 13/677,151.
- USPTO; Non-Final Office Action dated Aug. 20, 2013 in U.S. Appl. No. 13/679,502.
- USPTO; Final Office Action dated Feb. 25, 2014 in U.S. Appl. No. 13/679,502.
- USPTO; Notice of Allowance dated May 2, 2014 in U.S. Appl. No. 13/679,502.
- USPTO; Non-Final Office Action dated Jul. 21, 2015 in U.S. Appl. No. 13/727,324.
- USPTO; Final Office Action dated Jan. 22, 2016 in U.S. Appl. No. 13/727,324.
- USPTO; Non-Final Office Action dated 05/25/2016 in U.S. Appl. No. 13/727,324.
- USPTO; Final Office Action dated Dec. 1, 2016 in U.S. Appl. No. 13/727,324.
- USPTO; Notice of Allowance dated Mar. 1, 2017 in U.S. Appl. No. 13/727,324.
- USPTO; Non-Final Office Action dated Oct. 24, 2013 in U.S. Appl. No. 13/749,878.
- USPTO; Non-Final Office Action dated Jun. 18, 2014 in U.S. Appl. No. 13/749,878.
- USPTO; Final Office Action dated Dec. 10, 2014 in U.S. Appl. No. 13/749,878.
- USPTO; Notice of Allowance Mar. 13, 2015 dated in U.S. Appl. No. 13/749,878.
- USPTO; Office Action dated Apr. 23, 2014 in U.S. Appl. No. 13/784,362.

(56)

References Cited

OTHER PUBLICATIONS

- USPTO; Notice of Allowance dated Aug. 13, 2014 in U.S. Appl. No. 13/784,362.
- USPTO; Non-Final Office Action dated Dec. 19, 2013 in U.S. Appl. No. 13/784,388.
- USPTO; Notice of Allowance dated Jun. 4, 2014 in U.S. Appl. No. 13/784,388.
- USPTO; Restriction Requirement dated May 8, 2014 in U.S. Appl. No. 13/791,246.
- USPTO; Non-Final Office Action dated Sep. 19, 2014 in U.S. Appl. No. 13/791,246.
- USPTO; Final Office Action dated Mar. 25, 2015 in U.S. Appl. No. 13/791,246.
- USPTO; Non-Final Office Action dated Oct. 26, 2015 in U.S. Appl. No. 13/791,246.
- USPTO; Final Office Action dated Apr. 20, 2016 in U.S. Appl. No. 13/791,246.
- USPTO; Non-Final Office Action dated Aug. 11, 2016 in U.S. Appl. No. 13/791,246.
- USPTO; Notice of Allowance dated Nov. 25, 2016 in U.S. Appl. No. 13/791,246.
- USPTO; Non-Final Office Action dated Nov. 6, 2015 in U.S. Appl. No. 13/791,339.
- USPTO; Final Office Action dated Apr. 12, 2016 in U.S. Appl. No. 13/791,339.
- USPTO; Notice of Allowance dated Aug. 24, 2016 in U.S. Appl. No. 13/791,339.
- USPTO; Non-Final Office Action dated Mar. 21, 2014 in U.S. Appl. No. 13/799,708.
- USPTO; Notice of Allowance dated Oct. 31, 2014 in U.S. Appl. No. 13/799,708.
- USPTO; Non-Final Office Action dated Sep. 1, 2016 in U.S. Appl. No. 14/827,177.
- USPTO; Restriction Requirement dated Jun. 26, 2014 in U.S. Appl. No. 13/874,708.
- USPTO; Non-Final Office Action dated Oct. 9, 2014 in U.S. Appl. No. 13/874,708.
- USPTO; Notice of Allowance dated Mar. 10, 2015 in U.S. Appl. No. 13/874,708.
- USPTO; Notice of Allowance dated Apr. 10, 2014 in U.S. Appl. No. 13/901,341.
- USPTO; Notice of Allowance dated Jun. 6, 2014 in U.S. Appl. No. 13/901,341.
- USPTO; Non-Final Office Action dated Jan. 2, 2015 in U.S. Appl. No. 13/901,372.
- USPTO; Final Office Action dated Apr. 16, 2015 in U.S. Appl. No. 13/901,372.
- USPTO; Non-Final Office Action dated Jul. 8, 2015 in U.S. Appl. No. 13/901,400.
- USPTO; Final Office Action dated Jan. 14, 2016 in U.S. Appl. No. 13/901,400.
- USPTO; Notice of Allowance dated Apr. 12, 2016 in U.S. Appl. No. 13/901,400.
- USPTO; Notice of Allowance dated Aug. 5, 2015 in U.S. Appl. No. 13/901,372.
- USPTO; Non-Final Office Action dated Apr. 24, 2014 in U.S. Appl. No. 13/912,666.
- USPTO; Final Office Action dated Sep. 25, 2014 in U.S. Appl. No. 13/912,666.
- USPTO; Non-Final Office Action dated Jan. 26, 2015 in U.S. Appl. No. 13/912,666.
- USPTO; Notice of Allowance dated Jun. 25, 2015 in U.S. Appl. No. 13/912,666.
- USPTO; Non-Final Office Action dated Dec. 16, 2014 in U.S. Appl. No. 13/915,732.
- USPTO; Final Office Action dated Apr. 10, 2015 in U.S. Appl. No. 13/915,732.
- USPTO; Notice of Allowance dated Jun. 19, 2015 in U.S. Appl. No. 13/915,732.
- USPTO; Notice of Allowance dated Mar. 17, 2015 in U.S. Appl. No. 13/923,197.
- USPTO; Non-Final Office Action dated Sep. 12, 2014 in U.S. Appl. No. 13/941,134.
- USPTO; Notice of Allowance dated Jan. 20, 2015 in U.S. Appl. No. 13/941,134.
- USPTO; Restriction Requirement dated Apr. 30, 2015 in U.S. Appl. No. 13/941,216.
- USPTO; Non-Final Office Action dated Jul. 30, 2015 in U.S. Appl. No. 13/941,216.
- USPTO; Non-Final Office Action dated Jun. 15, 2016 in U.S. Appl. No. 13/941,216.
- USPTO; Notice of Allowance dated Sep. 13, 2016 in U.S. Appl. No. 13/941,216.
- USPTO; Restriction Requirement dated Sep. 16, 2014 in U.S. Appl. No. 13/948,055.
- USPTO; Non-Final Office Action dated Oct. 30, 2014 in U.S. Appl. No. 13/948,055.
- USPTO; Non-Final Office Action dated Jun. 29, 2015 in U.S. Appl. No. 13/966,782.
- USPTO; Final Office Action dated Jan. 4, 2016 in U.S. Appl. No. 13/966,782.
- USPTO; Notice of Allowance dated Oct. 7, 2015 in U.S. Appl. No. 13/973,777.
- USPTO; Non-Final Office Action dated Feb. 20, 2015 in U.S. Appl. No. 14/018,231.
- USPTO; Notice of Allowance dated Jul. 20, 2015 in U.S. Appl. No. 14/018,231.
- USPTO; Restriction Requirement Action dated Jan. 28, 2015 in U.S. Appl. No. 14/018,345.
- USPTO; Non-Final Office Action dated Apr. 7, 2015 in U.S. Appl. No. 14/018,345.
- USPTO; Final Office Action dated Sep. 14, 2015 in U.S. Appl. No. 14/018,345.
- USPTO; Notice of Allowance dated Jan. 14, 2016 in U.S. Appl. No. 14/018,345.
- USPTO; Notice of Allowance dated Mar. 17, 2016 in U.S. Appl. No. 14/018,345.
- USPTO; Non-Final Office Action dated Mar. 26, 2015 in U.S. Appl. No. 14/031,982.
- USPTO; Final Office Action dated Aug. 28, 2015 in U.S. Appl. No. 14/031,982.
- USPTO; Notice of Allowance dated Nov. 17, 2015 in U.S. Appl. No. 14/031,982.
- USPTO; Non-Final Office Action dated Apr. 28, 2015 in U.S. Appl. No. 14/040,196.
- USPTO; Notice of Allowance dated Sep. 11, 2015 in U.S. Appl. No. 14/040,196.
- USPTO; Non-Final Action dated Dec. 3, 2015 in U.S. Appl. No. 14/050,150.
- USPTO; Final Office Action dated Jun. 15, 2016 in U.S. Appl. No. 14/050,150.
- USPTO; Final Office Action dated Jul. 8, 2016 in U.S. Appl. No. 14/050,150.
- USPTO; Notice of Allowance dated Oct. 20, 2016 in U.S. Appl. No. 14/050,150.
- USPTO; Non-Final Office Action dated Dec. 15, 2014 in U.S. Appl. No. 14/065,114.
- USPTO; Final Office Action dated Jun. 19, 2015 in U.S. Appl. No. 14/065,114.
- USPTO; Non-Final Office Action dated Oct. 7, 2015 in U.S. Appl. No. 14/065,114.
- USPTO; Notice of Allowance dated Feb. 22, 2016 in U.S. Appl. No. 14/065,114.
- USPTO; Non-Final Office Action dated Nov. 14, 2014 in U.S. Appl. No. 14/069,244.
- USPTO; Notice of Allowance dated Mar. 25, 2015 in U.S. Appl. No. 14/069,244.
- USPTO; Non-Final Office Action dated Sep. 9, 2015 in U.S. Appl. No. 14/090,750.
- USPTO; Final Office Action dated Feb. 11, 2016 U.S. Appl. No. 14/090,750.

(56)

References Cited

OTHER PUBLICATIONS

USPTO; Non-Final Office Action dated Jun. 14, 2016 in U.S. Appl. No. 14/090,750.
USPTO; Final Office Action dated Sep. 28, 2016 in U.S. Appl. No. 14/090,750.
USPTO; Non-Final Office Action dated Jun. 23, 2017 in U.S. Appl. No. 14/090,750.
USPTO; Final Office Action dated Nov. 17, 2017 in U.S. Appl. No. 14/090,750.
USPTO; Non-Final Office Action dated Mar. 19, 2015 in U.S. Appl. No. 14/079,302.
USPTO; Final Office Action dated Sep. 1, 2015 in U.S. Appl. No. 14/079,302.
USPTO; Non-Final Office Action dated Apr. 27, 2016 in U.S. Appl. No. 14/079,302.
USPTO; Final Office Action dated Aug. 22, 2016 in U.S. Appl. No. 14/079,302.
USPTO; Notice of Allowance dated Dec. 14, 2016 in U.S. Appl. No. 14/079,302.
USPTO; Non-Final Office Action dated Mar. 19, 2015 in U.S. Appl. No. 14/166,462.
USPTO; Notice of Allowance dated Sep. 3, 2015 in U.S. Appl. No. 14/166,462.
USPTO; Non-Final Office Action dated Nov. 17, 2015 in U.S. Appl. No. 14/172,220.
USPTO; Office Action dated May 29, 2014 in U.S. Appl. No. 14/183,187.
USPTO; Final Office Action dated Nov. 7, 2014 in U.S. Appl. No. 14/183,187.
USPTO; Non-Final Office Action dated Mar. 16, 2015 in U.S. Appl. No. 14/183,187.
USPTO; Final Office Action dated Jul. 10, 2015 in U.S. Appl. No. 14/183,187.
USPTO; Non-Final Office Action dated Jan. 11, 2016 in U.S. Appl. No. 14/188,760.
USPTO; Final Office Action dated Aug. 25, 2016 in U.S. Appl. No. 14/188,760.
USPTO; Advisory Action dated Jan. 12, 2017 in U.S. Appl. No. 14/188,760.
USPTO; Non-Final Office Action dated Mar. 23, 2017 in U.S. Appl. No. 14/188,760.
USPTO; Final Office Action dated Oct. 5, 2017 in U.S. Appl. No. 14/188,760.
USPTO; Advisory Action dated Jan. 3, 2018 in U.S. Appl. No. 14/188,760.
USPTO; Non-Final Office Action dated Oct. 8, 2015 in U.S. Appl. No. 14/218,374.
USPTO; Final Office Action dated Feb. 23, 2016 in U.S. Appl. No. 14/218,374.
USPTO; Restriction Requirement dated May 20, 2016 in U.S. Appl. No. 14/218,690.
USPTO; Non-Final Office Action dated Jul. 15, 2016 in U.S. Appl. No. 14/218,690.
USPTO; Final Office Action dated Nov. 14, 2016 in U.S. Appl. No. 14/218,690.
USPTO; Non-Final Office Action dated Apr. 6, 2017 in U.S. Appl. No. 14/218,690.
USPTO; Final Office Action dated Jul. 20, 2017 in U.S. Appl. No. 14/218,690.
USPTO; Non-Final Office Action dated Jan. 11, 2018 in U.S. Appl. No. 14/218,690.
USPTO; Non-Final Office Action dated Sep. 22, 2015 in U.S. Appl. No. 14/219,839.
USPTO; Final Office Action dated Mar. 25, 2016 in U.S. Appl. No. 14/219,839.
USPTO; Non-Final Office Action dated Dec. 22, 2016 in U.S. Appl. No. 14/219,839.
USPTO; Non-Final Office Action dated Nov. 25, 2015 in U.S. Appl. No. 14/219,879.

USPTO; Non-Final Office Action dated Dec. 23, 2016 in U.S. Appl. No. 14/219,879.
USPTO; Final Office Action dated Jul. 6, 2017 in U.S. Appl. No. 14/219,879.
USPTO; Non-Final Office Action dated Sep. 18, 2015 in U.S. Appl. No. 14/244,689.
USPTO; Notice of Allowance dated Feb. 11, 2016 in U.S. Appl. No. 14/244,689.
USPTO; Non-Final Office Action dated Oct. 7, 2015 in U.S. Appl. No. 14/246,969.
USPTO; Final Office Action dated May 4, 2016 in U.S. Appl. No. 14/246,969.
USPTO; Non-Final Office Action dated Aug. 12, 2016 in U.S. Appl. No. 14/246,969.
USPTO; Non-Final Office Action dated Nov. 20, 2015 in U.S. Appl. No. 14/260,701.
USPTO; Notice of Allowance dated Jun. 2, 2016 in U.S. Appl. No. 14/260,701.
USPTO; Notice of Allowance dated Feb. 23, 2016 in U.S. Appl. No. 14/327,134.
USPTO; Non-Final Office Action dated Aug. 19, 2015 in U.S. Appl. No. 14/268,348.
USPTO; Non-Final Office Action dated Jan. 6, 2016 in U.S. Appl. No. 14/268,348.
USPTO; Final Office Action dated Apr. 29, 2016 in U.S. Appl. No. 14/268,348.
USPTO; Non-Final Office Action dated Oct. 20, 2015 in U.S. Appl. No. 14/281,477.
USPTO; Non-Final Office Action dated Jan. 13, 2017 in U.S. Appl. No. 14/444,744.
USPTO; Final Office Action dated Jul. 10, 2017 in U.S. Appl. No. 14/444,744.
USPTO; Non-Final Office Action dated Nov. 29, 2017 in U.S. Appl. No. 14/444,744.
USPTO; Non-Final Office Action dated May 18, 2016 in U.S. Appl. No. 14/449,838.
USPTO; Non-Final Office Action dated Feb. 12, 2015 in U.S. Appl. No. 14/457,058.
USPTO; Final Office Action dated Jul. 14, 2015 in U.S. Appl. No. 14/457,058.
USPTO; Non-Final Office Action dated Nov. 6, 2015 in U.S. Appl. No. 14/457,058.
USPTO; Final Office Action dated Jun. 17, 2016 in U.S. Appl. No. 14/457,058.
USPTO; Non-Final Office Action dated Oct. 6, 2016 in U.S. Appl. No. 14/457,058.
USPTO; Final Office Action dated May 4, 2017 in U.S. Appl. No. 14/457,058.
USPTO; Non-Final Office Action dated Sep. 16, 2016 in U.S. Appl. No. 14/465,252.
USPTO; Final Office Action dated Nov. 1, 2016 in U.S. Appl. No. 14/465,252.
USPTO; Non-Final Office Action dated Mar. 6, 2017 in U.S. Appl. No. 14/465,252.
USPTO; Final Office Action dated Jun. 9, 2017 in U.S. Appl. No. 14/465,252.
USPTO; Notice of Allowance dated Oct. 3, 2017 in U.S. Appl. No. 14/465,252.
USPTO; Non-Final Office Action dated Nov. 24, 2015 in U.S. Appl. No. 14/498,036.
USPTO; Final Office Action dated Apr. 5, 2016 in U.S. Appl. No. 14/498,036.
USPTO; Non-Final Office Action dated Apr. 10, 2015 in U.S. Appl. No. 14/505,290.
USPTO; Notice of Allowance dated Aug. 21, 2015 in U.S. Appl. No. 14/505,290.
USPTO; Non-Final Office Action dated Dec. 17, 2015 in U.S. Appl. No. 14/508,296.
USPTO; Final Office Action dated May 26, 2016 in U.S. Appl. No. 14/508,296.
USPTO; Non-Final Office Action dated Sep. 8, 2016 in U.S. Appl. No. 14/508,296.

(56)

References Cited

OTHER PUBLICATIONS

- USPTO; Final Office Action dated Dec. 7, 2016 in U.S. Appl. No. 14/508,296.
- USPTO; Non-Final Office Action dated Apr. 6, 2017 in U.S. Appl. No. 14/508,489.
- USPTO; Final Office Action dated Oct. 4, 2017 in U.S. Appl. No. 14/508,489.
- USPTO; Non-Final Office Action dated Jan. 16, 2015 in U.S. Appl. No. 14/563,044.
- USPTO; Final Office Action dated Jul. 16, 2015 in U.S. Appl. No. 14/563,044.
- USPTO; Notice of Allowance dated Oct. 15, 2015 in U.S. Appl. No. 14/563,044.
- USPTO; Notice of Allowance dated Dec. 2, 2015 in U.S. Appl. No. 14/563,044.
- USPTO; Non-Final Office Action dated May 4, 2016 in U.S. Appl. No. 14/568,647.
- USPTO; Final Office Action dated Sep. 29, 2016 in U.S. Appl. No. 14/568,647.
- USPTO; Non-Final Office Action dated Feb. 2, 2017 in U.S. Appl. No. 14/568,647.
- USPTO; Final Office Action dated May 19, 2017 in U.S. Appl. No. 14/568,647.
- USPTO; Non-Final Office Action dated Sep. 14, 2017 in U.S. Appl. No. 14/568,647.
- USPTO; Final Office Action dated Jan. 23, 2018 in U.S. Appl. No. 14/568,647.
- USPTO; Non-Final Office Action dated Oct. 1, 2015 in U.S. Appl. No. 14/571,126.
- USPTO; Final Office Action dated Feb. 22, 2016 in U.S. Appl. No. 14/571,126.
- USPTO; Notice of Allowance dated Jun. 2, 2016 in U.S. Appl. No. 14/571,126.
- USPTO; Non-Final Office Action dated Nov. 25, 2015 in U.S. Appl. No. 14/598,532.
- USPTO; Notice of Allowance dated May 16, 2016 in U.S. Appl. No. 14/598,532.
- USPTO; Non-Final Office Action dated Jan. 15, 2016 in U.S. Appl. No. 14/606,364.
- USPTO; Final Office Action dated Jan. 12, 2017 in U.S. Appl. No. 14/606,364.
- USPTO; Non-Final Office Action dated May 10, 2017 in U.S. Appl. No. 14/606,364.
- USPTO; Non-Final Office Action dated Mar. 3, 2016 in U.S. Appl. No. 14/622,603.
- USPTO; Non-Final Office Action dated Oct. 19, 2017 in U.S. Appl. No. 14/645,234.
- USPTO; Non-Final Office Action dated Jun. 7, 2017 in U.S. Appl. No. 14/656,588.
- USPTO; Final Office Action dated Dec. 26, 2017 in U.S. Appl. No. 14/656,588.
- USPTO; Non-Final Office Action dated Mar. 21, 2016 in U.S. Appl. No. 14/659,152.
- USPTO; Final Office Action dated Jul. 29, 2016 in U.S. Appl. No. 14/659,152.
- USPTO; Notice of Allowance dated Nov. 22, 2016 in U.S. Appl. No. 14/659,152.
- USPTO; Restriction Requirement dated Sep. 11, 2017 in U.S. Appl. No. 14/660,755.
- USPTO; Notice of Allowance dated Oct. 2, 2017 in U.S. Appl. No. 14/660,755.
- USPTO; Notice of Allowance dated Mar. 25, 2016 in U.S. Appl. No. 14/693,138.
- USPTO; Non-Final Office Action dated Aug. 3, 2017 in U.S. Appl. No. 14/752,712.
- USPTO; Final Office Action dated Nov. 29, 2017 in U.S. Appl. No. 14/752,712.
- USPTO; Non-Final Office Action dated Nov. 29, 2017 in U.S. Appl. No. 14/793,323.
- USPTO; Non-Final Office Action dated Jun. 16, 2017 in U.S. Appl. No. 14/798,136.
- USPTO; Notice of Allowance dated Oct. 5, 2017 in U.S. Appl. No. 14/798,136.
- USPTO; Non-Final Office Action dated Mar. 30, 2016 in U.S. Appl. No. 14/808,979.
- USPTO; Non-Final Office Action dated Dec. 20, 2016 in U.S. Appl. No. 14/808,979.
- USPTO; Final Office Action dated Jun. 8, 2017 in U.S. Appl. No. 14/808,979.
- USPTO; Non-Final Office Action dated Sep. 2017 in U.S. Appl. No. 14/808,979.
- USPTO; Non-Final Office Action dated Sep. 9, 2016 in U.S. Appl. No. 14/829,565.
- USPTO; Final Office Action dated Feb. 9, 2017 in U.S. Appl. No. 14/829,565.
- USPTO; Non-Final Office Action dated Sep. 19, 2017 in U.S. Appl. No. 14/829,565.
- USPTO; Non-Final Office Action dated Apr. 29, 2016 in U.S. Appl. No. 14/835,637.
- USPTO; Final Office Action dated Nov. 25, 2016 in U.S. Appl. No. 14/835,637.
- USPTO; Notice of Allowance dated Apr. 25, 2017 in U.S. Appl. No. 14/835,637.
- USPTO; Non-Final Office Action dated Jul. 29, 2016 in U.S. Appl. No. 14/884,695.
- USPTO; Final Office Action dated Feb. 9, 2017 in U.S. Appl. No. 14/884,695.
- USPTO; Non-Final Office Action dated May 18, 2017 in U.S. Appl. No. 14/884,695.
- USPTO; Non-Final Office Action dated May 18, 2017 in U.S. Appl. No. 14/886,571.
- USPTO; Final Office Action dated Sep. 21, 2017 in U.S. Appl. No. 14/886,571.
- USPTO; Notice of Allowance dated Dec. 6, 2017 in U.S. Appl. No. 14/886,571.
- USPTO; Non-Final Office Action dated Dec. 1, 2016 in U.S. Appl. No. 14/919,536.
- USPTO; Final Office Action dated Mar. 28, 2017 in U.S. Appl. No. 14/919,536.
- USPTO; Non-Final Office Action dated Aug. 29, 2017 in U.S. Appl. No. 14/919,536.
- USPTO; Non-Final Office Action dated Dec. 15, 2016 in U.S. Appl. No. 14/938,180.
- USPTO; Notice of Allowance dated Nov. 9, 2017 in U.S. Appl. No. 14/938,180.
- USPTO; Non-Final Office Action dated Apr. 14, 2017 in U.S. Appl. No. 14/956,115.
- USPTO; Final Office Action dated Jul. 21, 2017 in U.S. Appl. No. 14/956,115.
- USPTO; Notice of Allowance dated Dec. 14, 2017 in U.S. Appl. No. 14/956,115.
- USPTO; Notice of Allowance dated Feb. 3, 2017 in U.S. Appl. No. 14/977,291.
- USPTO; Non-Final Office Action dated Aug. 12, 2016 in U.S. Appl. No. 14/981,434.
- USPTO; Non-Final Office Action dated Jan. 12, 2017 in U.S. Appl. No. 14/981,468.
- USPTO; Notice of Allowance dated Jun. 7, 2017 in U.S. Appl. No. 14/981,468.
- USPTO; Non-Final Office Action dated Mar. 22, 2016 in U.S. Appl. No. 14/987,420.
- USPTO; Non-Final Office Action dated Dec. 14, 2016 in U.S. Appl. No. 14/997,683.
- USPTO; Final Office Action dated Apr. 14, 2017 in U.S. Appl. No. 14/997,683.
- USPTO; Non-Final Office Action dated Sep. 1, 2017 in U.S. Appl. No. 14/997,683.
- USPTO; Non-Final Office Action dated Sep. 23, 2016 in U.S. Appl. No. 15/048,422.
- USPTO; Notice of Allowance dated May 4, 2017 in U.S. Appl. No. 15/048,422.

(56)

References Cited

OTHER PUBLICATIONS

- USPTO; Non-Final Office Action dated Aug. 4, 2017 in U.S. Appl. No. 15/050,159.
- USPTO; Non-Final Office Action dated Jan. 9, 2018 in U.S. Appl. No. 15/135,224.
- USPTO; Non-Final Office Action dated Jan. 9, 2018 in U.S. Appl. No. 15/135,258.
- USPTO; Non-Final Office Action dated Jan. 9, 2018 in U.S. Appl. No. 15/135,333.
- USPTO; Non-Final Office Action dated Nov. 21, 2016 in U.S. Appl. No. 15/144,481.
- USPTO; Final Office Action dated May 26, 2017 in U.S. Appl. No. 15/144,481.
- USPTO; Non-Final Office Action dated Sep. 21, 2017 in U.S. Appl. No. 15/144,481.
- USPTO; Non-Final Office Action dated Apr. 13, 2017 in U.S. Appl. No. 15/144,506.
- USPTO; Final Office Action dated Oct. 10, 2017 in U.S. Appl. No. 15/144,506.
- USPTO; Non-Final Office Action dated Nov. 29, 2016 in U.S. Appl. No. 15/203,642.
- USPTO; Final Office Action dated Apr. 13, 2017 in U.S. Appl. No. 15/203,642.
- USPTO; Notice of Allowance dated Aug. 7, 2017 in U.S. Appl. No. 15/203,642.
- USPTO; Non-Final Office Action dated Nov. 28, 2016 in U.S. Appl. No. 15/203,632.
- USPTO; Non-Final Office Action dated Jun. 7, 2017 in U.S. Appl. No. 15/203,632.
- USPTO; Notice of Allowance dated Sep. 20, 2017 in U.S. Appl. No. 15/203,632.
- USPTO; Non-Final Office Action dated Jun. 1, 2017 in U.S. Appl. No. 15/205,827.
- USPTO; Final Office Action dated Oct. 16, 2017 in U.S. Appl. No. 15/205,827.
- USPTO; Non-Final Office Action dated Mar. 31, 2017 in U.S. Appl. No. 15/205,890.
- USPTO; Notice of Allowance dated Oct. 16, 2017 in U.S. Appl. No. 15/205,890.
- USPTO; Non-Final Office Action dated Apr. 21, 2017 in U.S. Appl. No. 15/222,715.
- USPTO; Notice of Allowance dated Jul. 14, 2017 in U.S. Appl. No. 15/222,715.
- USPTO; Notice of Allowance dated Sep. 27, 2017 in U.S. Appl. No. 15/222,715.
- USPTO; Non-Final Office Action dated Feb. 3, 2017 in U.S. Appl. No. 15/222,738.
- USPTO; Notice of Allowance dated Aug. 23, 2017 in U.S. Appl. No. 15/222,738.
- USPTO; Non-Final Office Action dated Jan. 17, 2017 in U.S. Appl. No. 15/222,749.
- USPTO; Final Office Action dated May 5, 2017 in U.S. Appl. No. 15/222,749.
- USPTO; Non-Final Office Action dated Sep. 7, 2017 in U.S. Appl. No. 15/222,749.
- USPTO; Non-Final Office Action dated Jan. 3, 2017 in U.S. Appl. No. 15/222,780.
- USPTO; Final Office Action dated May 5, 2017 in U.S. Appl. No. 15/222,780.
- USPTO; Non-Final Office Action dated Sep. 7, 2017 in U.S. Appl. No. 15/222,780.
- USPTO; Non-Final Office Action dated Aug. 28, 2017 in U.S. Appl. No. 15/254,724.
- USPTO; Notice of Allowance dated Jan. 17, 2018 in U.S. Appl. No. 15/254,724.
- USPTO; Non-Final Office Action dated Oct. 23, 2017 in U.S. Appl. No. 15/377,439.
- USPTO; Notice of Allowance dated Aug. 8, 2017 in U.S. Appl. No. 15/380,410.
- USPTO; Notice of Allowance dated Oct. 11, 2017 in U.S. Appl. No. 15/380,895.
- USPTO; Non-Final Office Action dated Jan. 4, 2018 in U.S. Appl. No. 15/380,921.
- USPTO; Non-Final Office Action dated Aug. 11, 2017 in U.S. Appl. No. 15/397,237.
- USPTO; Notice of Allowance dated Dec. 22, 2017 in U.S. Appl. No. 15/397,237.
- USPTO; Non-Final Office Action dated Apr. 12, 2017 in U.S. Appl. No. 15/397,319.
- USPTO; Final Office Action dated Jul. 12, 2017 in U.S. Appl. No. 15/397,319.
- USPTO; Notice of Allowance dated Dec. 15, 2017 in U.S. Appl. No. 15/397,319.
- USPTO; Notice of Allowance dated Oct. 6, 2017 in U.S. Appl. No. 15/450,199.
- USPTO; Non-Final Office Action dated Dec. 15, 2017 in U.S. Appl. No. 15/466,149.
- USPTO; Non-Final Office Action dated Dec. 6, 2017 in U.S. Appl. No. 15/476,035.
- USPTO; Non-Final Office Action dated Oct. 4, 2017 in U.S. Appl. No. 15/489,453.
- USPTO; Non-Final Office Action dated Jan. 16, 2018 in U.S. Appl. No. 15/499,647.
- USPTO; Non-Final Office Action dated Dec. 26, 2017 in U.S. Appl. No. 15/798,120.
- USPTO; Non-Final Office Action dated Mar. 16, 2015 in U.S. Appl. No. 29/447,298.
- USPTO; Notice of Allowance dated Jul. 6, 2015 in U.S. Appl. No. 29/447,298.
- USPTO; Notice of Allowance dated Nov. 26, 2014 in U.S. Appl. No. 29/481,301.
- USPTO; Notice of Allowance dated Feb. 17, 2015 in U.S. Appl. No. 29/481,308.
- USPTO; Notice of Allowance dated Jan. 12, 2015 in U.S. Appl. No. 29/481,312.
- USPTO; Notice of Allowance dated Apr. 30, 2015 in U.S. Appl. No. 29/481,315.
- USPTO; Notice of Allowance dated May 11, 2015 in U.S. Appl. No. 29/511,011.
- USPTO; Notice of Allowance dated May 11, 2015 in U.S. Appl. No. 29/514,153.
- USPTO; Notice of Allowance dated Dec. 14, 2015 in U.S. Appl. No. 29/514,264.
- PCT; International Search report and Written Opinion dated Nov. 12, 2010 in Application No. PCT/US2010/030126.
- PCT; International Preliminary Report on Patentability dated Oct. 11, 2011 Application No PCT/US2010/030126.
- PCT; International Search report and Written Opinion dated Jan. 20, 2011 in Application No. PCT/US2010/045368.
- PCT; International Search report and Written Opinion dated Feb. 6, 2013 in Application No. PCT/US2012/065343.
- PCT; International Search report and Written Opinion dated Feb. 13, 2013 in Application No. PCT/US2012/065347.
- Chinese Patent Office; Office Action dated Jan. 10, 2013 in Application No. 201080015699.9.
- Chinese Patent Office; Office Action dated Jan. 12, 2015 in Application No. 201080015699.9.
- Chinese Patent Office; Office Action dated May 24, 2013 in Application No. 201080036764.6.
- Chinese Patent Office; Office Action dated Jan. 2, 2014 in Application No. 201080036764.6.
- Chinese Patent Office; Office Action dated Jul. 1, 2014 in Application No. 201080036764.6.
- Chinese Patent Office; Office Action dated Feb. 8, 2014 in Application No. 201110155056.
- Chinese Patent Office; Office Action dated Sep. 16, 2014 in Application No. 201110155056.
- Chinese Patent Office; Office Action dated Feb. 9, 2015 in Application No. 201110155056.
- Japanese Patent Office; Office Action dated Jan. 25, 2014 in Application No. 2012-504786.

(56)

References Cited

OTHER PUBLICATIONS

Japanese Patent Office; Office Action dated Dec. 1, 2014 in Application No. 2012-504786.

Korean Patent Office; Office Action dated Dec. 10, 2015 in Application No. 10-2010-0028336.

Taiwan Patent Office; Office Action dated Jul. 4, 2014 in Application No. 099110511.

Taiwan Patent Office; Office Action dated Dec. 19, 2014 in Taiwan Application No. 099127063.

Taiwan Patent Office; Office Action dated May 13, 2016 in Taiwan Application No. 101142582.

Bearzotti, et al., "Fast Humidity Response of a Metal Halide-Doped Novel Polymer," *Sensors and Actuators B*, 7, pp. 451-454, (1992).

Becker et al., "Atomic Layer Deposition of Insulating Hafnium and Zirconium Nitrides," *Chem. Mater.*, 16, 3497-3501 (2004).

Bhatnagar et al., "Copper Interconnect Advances to Meet Moore's Law Milestones," *Solid State Technology*, 52, 10 (2009).

Buriak, "Organometallic Chemistry on Silicon and Germanium Surfaces," *Chemical Reviews*, 102, 5 (2002).

Cant et al., "Chemisorption Sites on Porous Silica Glass and on Mixed-Oxide Catalysis," *Can. J. Chem.* 46, 1373 (1968).

Chang et al., "Small-Subthreshold-Swing and Low-Voltage Flexible Organic Thin-Film Transistors Which Use HfLaO as the Gate Dielectric," *IEEE Electron Device Letters*, Feb. 2009, pp. 133-135; vol. 30, No. 2: IEEE Electron Device Society.

Chatterjee et al., "Sub-100nm Gate Length Metal Gate NMOS Transistors Fabricated by a Replacement by a Replacement Gate Process," *IEEE Semiconductor Process and Device Center*, 821-824 (1997).

Chen et al., "A Self-Aligned Airgap Interconnect Scheme," *IEEE International Interconnect Technology Conference*, vol. 1-3, 146-148 (2009).

Choi et al., "Improvement of Silicon Direct Bonding using Surfaces Activated by Hydrogen Plasma Treatment," *Journal of the Korean Physical Society*, 37, 6, 878-881 (2000).

Choi et al., "Low Temperature Formation of Silicon Oxide Thin Films by Atomic Layer Deposition Using NH₃/O₂ Plasma," *ECS Solid State Letters*, 2(12) p. 114-p. 116 (2013).

Coates, "Process Analytical Technology: Spectroscopic Tools and Implementation Strategies for the Chemical and Pharmaceutical Industries." Blackwell Publishing Ltd, 91-132, (2005).

Crowell, "Chemical methods of thin film deposition: Chemical vapor deposition, atomic layer deposition, and related technologies," *Journal of Vacuum Science & Technology A* 21.5, (2003): S88-S95.

Cui et al., "Impact of Reductive N₂/H₂ Plasma on Porous Low-Dielectric Constant SiCOH Thin Films," *Journal of Applied Physics* 97, 113302, 1-8 (2005).

Dingemans et al., "Comparison Between Aluminum Oxide Surface Passivation Films Deposited with Thermal Aid," *Plasma Aid and Pecvd*, 35th IEEE PVCS, Jun. (2010).

Drummond et al., "Hydrophobic Radiofrequency Plasma-Deposited Polymer Films: Dielectric Properties and Surface Forces," *Colloids and Surfaces A*, 129-130, 117-129 (2006).

Easley et al., "Thermal Isolation of Microchip Reaction Chambers for Rapid Non-Contact DNA Amplification," *J. Micromech. Microeng.* 17, 1758-1766 (2007).

Ge et al., "Carbon Nanotube-Based Synthetic Gecko Tapes," *Department of Polymer Science, PNAS*, 10792-10795 (2007).

George et al., "Atomic Layer Deposition: An Overview," *Chem. Rev.* 110, 111-131 (2010).

Grill et al., "The Effect of Plasma Chemistry on the Damage Induced Porous SiCOH Dielectrics," *IBM Research Division, RC23683 (W0508-008), Materials Science*, 1-19 (2005).

Gupta et al., "Conversion of Metal Carbides to Carbide Derived Carbon by Reactive Ion Etching in Halogen Gas," *Proceedings of SPIE—The International Society for Optical Engineering and Nanotechnologies for Space Applications*, ISSN: 0277-786X (2006).

Harrison et al., "Poly-gate Replacement Through Contact Hole (PRETCH): A New Method for High-K/ Metal Gate and Multi-Oxide Implementation on Chip," *IEEE* (2004).

Heo et al., "Structural Characterization of Nanoporous Low-Dielectric Constant SiCOH Films Using Organosilane Precursors," *NSTI-Nanotech*, vol. 4, 122-123 (2007).

H.J. Yun et al., "Comparison of Atomic Scale Etching of Poly-Si in Inductively Coupled Ar and He Plasmas", *Korean Journal of Chemical Engineering*, vol. 24, 670-673 (2007).

Hubert et al., "A Stacked SONOS Technology, up to 4 Levels and 6nm Crystalline Nanowires, With Gate-All-Around or Independent Gates (-Flash), Suitable for Full 3D Integration," *Minatex, IEDM09-637-640* (2009).

Jones et al., "Growth of Aluminium Films by Low Pressure Chemical Vapour Deposition Using Tertiarybutylaluminium," *Journal of Crystal Growth* 135, pp. 285-289, Elsevier Science B.V. (1994).

Jones et al., "Recent Developments in Metalorganic Precursors for Metalorganic Chemical Vapour Deposition," *Journal of Crystal Growth* 146, pp. 503-510, Elsevier Science B.V. (1995).

Jung et al., "Double Patterning of Contact Array with Carbon Polymer," *Proc. Of SPIE*, 6924, 69240C, 1-10 (2008).

Katamreddy et al., "ALD and Characterization of Aluminum Oxide Deposited on Si(100) using Tris(diethylamino) Aluminum and Water Vapor," *Journal of The Electrochemical Society*, 153 (10) C701-C706 (2006).

Kim et al., "Passivation Effect on Low-k S/OC Dielectrics by H₂ Plasma Treatment," *Journal of the Korean Physical Society*, 40, 1, 94-98 (2002).

Kim et al., "Characteristics of Low Temperature High Quality Silicon Oxide by Plasma Enhanced Atomic Layer Deposition with In-Situ Plasma Densification Process," *The Electrochemical Society, ECS Transactions. College of Information and Communication Engineering, Sungkyunkwan University*, 53(1).

King, Plasma Enhanced Atomic Layer Deposition of SiN_x: H and SiO₂, *J. Vac. Sci. Technol.*, A29(4) (2011).

Kobayshi, et al., "Temperature Dependence of SiO₂ Film Growth with Plasma-Enhanced Atomic Layer Deposition," regarding Thin Solid Films, published by Elsevier in the *International Journal on the Science and Technology of Condensed Matter*, in vol. 520, No. 11, 3994-3998 (2012).

Koo et al., "Characteristics of Al₂O₃ Thin Films Deposited Using Dimethylaluminum Isopropoxide and Trimethylaluminum Precursors by the Plasma-Enhanced Atomic-Layer Deposition Method," *Journal of Physical Society*, 48, 1, 131-136 (2006).

Koutsokeras et al. "Texture and Microstructure Evolution in Single-Phase TixTal—xN Alloys of Rocksalt Structure," *Journal of Applied Physics*, 110, pp. 043535-1-043535-6, (2011).

Klug et al., "Atomic Layer Deposition of Amorphous Niobium Carbide-Based Thin Film Superconductors," *The Journal of Physical Chemistry*, 115, 25063-25071 (2011).

Knoops et al., "Atomic Layer Deposition of Silicon Nitride from Bis(tert-butylamino) silane and N₂ Plasma," *Applied Materials & Interfaces, American Chemical Society*, A-E (2015).

Krenek et al. "IR Laser CVD of Nanodisperse Ge—Si—Sn Alloys Obtained by Dielectric Breakdown of GeH₄/SiH₄/SnH₄ Mixtures", *NanoCon 2014, Nov. 5-7, Brno, Czech Republic, EU*.

Kurosawa et al., "Synthesis and Characterization of Plasma-Polymerized Hexamethyldisiloxane Films," *Thin Solid Films*, 506-507, 176-179 (2006).

Lanford et al., "The Hydrogen Content of Plasmadeposited Silicon Nitride," *J. Appl. Phys.*, 49, 2473 (1978).

Lee et al., Layer Selection by Multi-Level Permutation in 3-D Stacked NAND Flash Memory, *IEEE Electron Device Letters*, vol. 37, No. 7, 866-869 (2016).

Lieberman, et al., "Principles of Plasma Discharges and Materials Processing," Second Edition, 368-381.

Lim et al., "Low-Temperature Growth of SiO₂ Films by Plasma-Enhanced Atomic Layer Deposition," *ETRI Journal*, 27 (1), 118-121 (2005).

Liu et al., "Research, Design, and Experiment of End Effector for Wafer Transfer Robot," *Industrial Robot: An International Journal*, 79-91 (2012).

(56)

References Cited

OTHER PUBLICATIONS

- Mackus et al., "Optical Emission Spectroscopy as a Tool for Studying Optimizing, and Monitoring Plasma-Assisted Atomic Layer Deposition Processes," *Journal of Vacuum Science and Technology*, 77-87 (2010).
- Maeno, "Gecko Tape Using Carbon Nanotubes," *Nitto Denko Gihou*, 47, 48-51.
- Maeng et al. Electrical properties of atomic layer disposition HfO₂ and HfO_xN_y on Si substrates with various crystal orientations, *Journal of the Electrochemical Society*, 2008-04, p. H267-H271, vol. 155, No. 4, Department of Materials Science and Engineering, Pohang University of Science and Technology, Pohang, Korea.
- Marsik et al., "Effect of Ultraviolet Curing Wavelength on Low-k Dielectric Material Properties and Plasma Damage Resistance," *Sciencedirect.com*, 519, 11, 3619-3626 (2011).
- Mason et al., "Hydrolysis of Tri-tert-butylaluminum: The First Structural Characterization of Alkylalumoxanes [(R₂Al)O]_n and (RAIO)_n," *J. American Chemical Society*, vol. 115, No. 12, pp. 4971-4984 (1993).
- Massachusetts Institute of Technology Lincoln Laboratory, "Solid State Research," Quarterly Technical Report (1995).
- Meng et al., "Atomic Layer of Deposition of Silicon Nitride Thin Films: A Review of Recent Progress, Challenges, and Outlooks," *Materials*, 9, 1007 (2016).
- Moeen, "Design, Modelling and Characterization of Si/SiGe Structures for IR Bolometer Applications," KTH Royal Institute of Technology. Information and Communication Technology, Department of Integrated Devices and Circuits, Stockholm Sweden (2015).
- Morishige et al., "Thermal Desorption and Infrared Studies of Ammonia Amines and Pyridines Chemisorbed on Chromic Oxide," *J.Chem. Soc., Faraday Trans. 1*, 78, 2947-2957 (1982).
- Mosleh et al., "Enhancement of Material Quality of (Si)GeSn Films Grown by SnC₁₄ Precursor," *ECS Transactions*, 69 (5), 279-285 (2015).
- Mukai et al., "A Study of CD Budget in Spacer Patterning Technology," *Proc. Of SPIE*, 6924, 1-8 (2008).
- Nigamananda et al., "Low-Temperature (<200oC) Plasma. Enhanced Atomic Deposition of Dense Titanium Nitride Thin Films."
- Nogueira et al., "Production of Highly Hydrophobic Films Using Low Frequency and High Density Plasma," *Revista Brasileira de Aplicacoes de Vacuo*, 25(1), 45-53 (2006).
- Novaro et al. Theoretical Study on a Reaction Pathway of Ziegler-Natta-Type Catalysis, *J. Chem. Phys.* 68(5), Mar. 1, 1978 p. 2337-2351.
- S. Okamoto et al., "Luminescent Properties of Pr³⁺—sensitized LaPO₄: Gd³⁺ Ultraviolet-B Phosphor Under Vacuum-Ultraviolet Light Excitation," *J. App. Phys.* 106, 013522 (2009).
- Park., "Substituted Aluminum Metal Gate on High-K Dielectric for Low Work-Function and Fermi-Level Pinning Free," 4 pages, *IEEE 0-7803-8684-1/04* (2004).
- Portet et al., "Impact of Synthesis Conditions on Surface Chemistry and Structure of Carbide-Derived Carbons," *Thermochimica Acta*, 497, 137-142 (2010).
- Potts et al., "Low Temperature Plasma-Enhanced Atomic Layer Deposition of metal Oxide Thin Films," *Journal of the Electrochemical Society*, 157, 66-74 (2010).
- Presser, et al., "Effect of Pore Size on Carbon Dioxide Sorption by Carbide Derived Carbon," *Energy & Environmental Science* 4.8, 3059-3066 (2011).
- Provine et al., "Correlation of Film Density and Wet Etch Rate in Hydrofluoric Acid of Plasma Enhanced Atomic Layer Deposited Silicon Nitride," *AIP Advances*, 6 (2016).
- Radamson et al. "Growth of Sn-alloyed Group IV Materials for Photonic and Electronic Applications", Chapter 5 pp. 129-144, *Manufacturing NanoStructures*.
- Sakuma et al., "Highly Scalable Horizontal Channel 3-D NAND Memory Excellent in Compatibility with Conventional Fabrication Technology," *IEEE Electron Device Letters*, vol. 34, No. 9, 1142-1144 (2013).
- Salim, "In-situ Fourier Transform Infrared Spectroscopy of Chemistry and Growth in Chemical Vapor Deposition," *Massachusetts Institute of Technology*, 187 pages (1995).
- Salim et al., "In Situ Concentration Monitoring in a Vertical OMVPE Reactor by Fiber-Optics-Based Fourier Transform Infrared Spectroscopy," *Journal of Crystal Growth* 169, pp. 443-449, Elsevier Science B.V. (1996).
- Selvaraj et al., "Selective Atomic Layer Deposition of Zirconia on Copper Patterened Silicon Substrates Using Ethanol as Oxygen Source as Well as Copper Reductant," *J. Vac. Sci. Technol.* A32(1), (2014).
- Schmatz et al., "Unusual Isomerization Reactions in 1.3-Diaza-2-Silcyclopentanes," *Organometallics*, 23, 1180-1182 (2004).
- Scientific and Technical Information Center EIC 2800 Search Report dated Feb. 16, 2012.
- S.D. Athavale and D.J. Economou, "Realization of Atomic Layer Etching of Silicon", *Journal of Vacuum Science and Technology B*, vol. 14, year 1996, pp. 3702-3705.
- Shamma et al., "PDL Oxide Enabled Doubling," *Proc. Of SPIE*, 6924, 69240D, 1-10 (2008).
- Tseng et al., "Enhanced Block Copolymer Lithography Using Sequential Infiltration Synthesis," *The Journal of Physical Chemistry*, 17725-17729 (2011).
- Tseng et al., "Etch Properties of Resists Modified by Sequential Infiltration Synthesis," *Journal of Vacuum Science & Technology*, 29, (2011).
- Varma, et al., "Effect of Metal Halides on Thermal, Mechanical, and Electrical Properties of Polypyromelitimide Films," *Journal of Applied Polymer Science*, vol. 32, pp. 3987-4000, (1986).
- Wang et al., "Tertiarybutylaluminum as an Organometallic Source for Epitaxial Growth of AlGaSb," *Appl. Phys. Lett.* 67 (10), Sep. 4, pp. 1384-1386, *American Institute of Physics* (1995).
- Wirths, et al, "SiGeSn Growth studies Using Reduced Pressure Chemical Vapor Deposition Towards Optoeleconic Applications," *This Soid Films*, 557, 183-187 (2014).
- Yoshida, et al., Threshold Voltage Tuning for 10NM and Beyond CMOS Integration, *Solid State Technology*, 57(7): 23-25 (2014).
- Yu et al., "Modulation of the Ni FUSI Workfunction by Yb Doping: from Midgap to N-Type Band-Edge," 4 pages, *IEEE 0-7803-9269-8/05* (2005).
- Yun et al., "Behavior of Various Organosilicon Molecules in PECVD Processes for Hydrocarbon-Doped Silicon Oxide Films," *Solid State Phenomena*, vol. 124-126, 347-350 (2007).
- Yun et al., "Single-Crystalline Si Stacked Array (STAR) NAND Flash Memory," *IEEE Transactions on Electron Devices*, vol. 58, No. 4, 1006-1014 (2011).
- Yun et al., "Effect of Plasma on Characteristics of Zirconium Oxide Films Deposited by Plasma-Enhanced Atomic Layer Deposition," *Electrochemical and Solid State Letters*, 8(11) F47-F50 (2005).
- Yushin et al., "Carbon-Derived Carbon," *Department of Materials Science and Engineering, Taylor & Francis Group, LLC* (2006).
- Chemistry Stack Exchange, "Why is CF₄ Non-Polar and CHF₃ Polar," <https://chemistry.stackexchange.com/questions/31604/why-is-cf4-non-polar-and-chf3-polar>, (2015).
- USPTO; Notice of Allowance dated Jul. 26, 2005 in U.S. Appl. No. 10/033,058.
- USPTO; Non-Final Office Action dated Aug. 25, 2005 in U.S. Appl. No. 10/191,635.
- USPTO; Final Office Action dated Apr. 25, 2006 in U.S. Appl. No. 10/191,635.
- USPTO; Non-Final Office Action dated Nov. 20, 2006 in U.S. Appl. No. 10/191,635.
- USPTO; Notice of Allowance dated May 21, 2007 in U.S. Appl. No. 10/191,635.
- USPTO; Notice of Allowance dated Feb. 20, 2008 in U.S. Appl. No. 10/191,635.
- USPTO; Non-Final Office Action dated May 13, 2003 in U.S. Appl. No. 10/222,229.
- USPTO; Non-Final Office Action dated Oct. 22, 2003 in U.S. Appl. No. 10/222,229.
- USPTO; Final Office Action dated Mar. 22, 2004 in U.S. Appl. No. 10/222,229.

(56)

References Cited

OTHER PUBLICATIONS

- USPTO; Advisory Action dated Oct. 7, 2004 in U.S. Appl. No. 10/222,229.
- USPTO; Non-Final Office Action dated Dec. 22, 2004 in U.S. Appl. No. 10/222,229.
- USPTO; Final Office Action dated Jun. 20, 2005 in U.S. Appl. No. 10/222,229.
- USPTO; Advisory Action dated Nov. 16, 2005 in U.S. Appl. No. 10/222,229.
- USPTO; Notice of Allowance dated Mar. 8, 2006 in U.S. Appl. No. 10/222,229.
- USPTO; Non-Final Office Action dated Jan. 26, 2005 in U.S. Appl. No. 10/838,510.
- USPTO; Notice of Allowance dated Jul. 12, 2005 in U.S. Appl. No. 10/838,510.
- USPTO; Non-Final Office Action dated Mar. 28, 2010 in U.S. Appl. No. 12/121,085.
- USPTO; Notice of Allowance dated Jul. 26, 2010 in U.S. Appl. No. 12/121,085.
- USPTO; Notice of Allowance dated Oct. 4, 2010 in U.S. Appl. No. 12/121,085.
- USPTO; Non-Final Office Action dated Sep. 13, 2010 in U.S. Appl. No. 12/140,809.
- USPTO; Final Office Action dated Dec. 28, 2010 in U.S. Appl. No. 12/140,809.
- USPTO; Notice of Allowance dated Mar. 17, 2011 in U.S. Appl. No. 12/140,809.
- USPTO; Non-Final Office Action dated Mar. 15, 2011 in U.S. Appl. No. 12/193,924.
- USPTO; Foma; Office Action dated Sep. 30, 2011 in U.S. Appl. No. 12/193,924.
- USPTO; Non-Final Office Action dated Oct. 24, 2012 in U.S. Appl. No. 12/193,924.
- USPTO; Final Office Action dated Apr. 17, 2013 in U.S. Appl. No. 12/193,924.
- USPTO; Advisory Action dated Jul. 9, 2013 in U.S. Appl. No. 12/193,924.
- USPTO; Non-Final Office Action dated Jul. 28, 2011 in U.S. Appl. No. 12/330,096.
- USPTO; Final Office Action dated Jan. 13, 2012 in U.S. Appl. No. 12/330,096.
- USPTO; Notice of Allowance dated Mar. 6, 2012 in U.S. Appl. No. 12/330,096.
- USPTO; Non-Final Office Action dated Mar. 20, 2012 in U.S. Appl. No. 12/330,096.
- USPTO; Notice of Allowance dated Jun. 7, 2012 in U.S. Appl. No. 12/330,096.
- USPTO; Notice of Allowance dated Apr. 2, 2012 in U.S. Appl. No. 12/416,809.
- USPTO; Advisory Action dated Feb. 3, 2012 in U.S. Appl. No. 12/416,809.
- USPTO; Non-Final Office Action dated Aug. 3, 2011 in U.S. Appl. No. 12/436,300.
- USPTO; Final Office Action dated Jan. 23, 2012 in U.S. Appl. No. 12/436,300.
- USPTO; Advisory Action dated Mar. 6, 2012 in U.S. Appl. No. 12/436,300.
- USPTO; Non-Final Office Action dated May 22, 2012 in U.S. Appl. No. 12/436,300.
- USPTO; Notice of Allowance dated Nov. 28, 2012 in U.S. Appl. No. 12/436,300.
- USPTO; Restriction Requirement dated Dec. 20, 2011 in U.S. Appl. No. 12/436,306.
- USPTO; Non-Final Office Action dated Apr. 11, 2012 in U.S. Appl. No. 12/436,306.
- USPTO; Final Office Action dated Sep. 26, 2012 in U.S. Appl. No. 12/436,306.
- USPTO; Non-Final Office Action dated May 31, 2013 in U.S. Appl. No. 12/436,306.
- USPTO; Final Office Action dated Oct. 17, 2013 in U.S. Appl. No. 12/436,306.
- USPTO; Advisory Action dated Oct. 1, 2014 in U.S. Appl. No. 12/436,306.
- USPTO; Non-Final Office Action dated Feb. 4, 2014 in U.S. Appl. No. 12/436,306.
- USPTO; Final Office Action dated Jun. 23, 2014 in U.S. Appl. No. 12/436,306.
- USPTO; Non-Final Office Action dated Feb. 3, 2015 in U.S. Appl. No. 12/436,306.
- USPTO; Final Office Action dated May 13, 2015 in U.S. Appl. No. 12/436,306.
- USPTO; Non-Final Office Action dated Oct. 14, 2015 in U.S. Appl. No. 12/436,306.
- USPTO; Final Office Action dated Dec. 31, 2015 in U.S. Appl. No. 12/436,306.
- USPTO; Notice of Allowance dated Feb. 3, 2016 in U.S. Appl. No. 12/436,306.
- USPTO; Non-Final Office Action dated Aug. 3, 2011 in U.S. Appl. No. 12/436,315.
- USPTO; Notice of Allowance dated Nov. 17, 2011 in U.S. Appl. No. 12/436,315.
- USPTO; Advisory Action dated Jul. 13, 2011 in U.S. Appl. No. 12/553,759.
- USPTO; Advisory Action dated Jul. 23, 2013 in U.S. Appl. No. 12/618,355.
- USPTO; Advisory Action dated Mar. 4, 2016 in U.S. Appl. No. 12/618,355.
- USPTO; Advisory Action dated May 16, 2017 in U.S. Appl. No. 12/618,355.
- USPTO; Non-Final Office Action dated Nov. 29, 2017 in U.S. Appl. No. 12/618,355.
- USPTO; Final Office Action dated Aug. 10, 2018 in U.S. Appl. No. 12/618,355.
- USPTO; Advisory Action dated Aug. 9, 2012 in U.S. Appl. No. 12/618,419.
- USPTO; Notice of Allowance dated Oct. 9, 2013 in U.S. Appl. No. 12/618,419.
- USPTO; Requirement for Restriction dated Sep. 12, 2011 in U.S. Appl. No. 12/718,731.
- USPTO; Advisory Action dated Jul. 1, 2013 in U.S. Appl. No. 12/847,848.
- USPTO; Requirement for Restriction dated Jul. 22, 2013 in U.S. Appl. No. 12/910,607.
- USPTO; Advisory Action dated Jul. 9, 2014 in U.S. Appl. No. 12/910,607.
- USPTO; Advisory Action dated Jul. 8, 2013 in U.S. Appl. No. 12/953,870.
- USPTO; Non-Final Office Action dated Aug. 28, 2013 in U.S. Appl. No. 12/953,870.
- USPTO; Final Office Action dated Apr. 17, 2014 in U.S. Appl. No. 12/953,870.
- USPTO; Requirement for Restriction dated Sep. 10, 2010 in U.S. Appl. No. 12/148,956.
- USPTO; Advisory Action dated Jun. 12, 2014 in U.S. Appl. No. 13/102,980.
- USPTO; Notice of Allowance dated Sep. 17, 2014 in U.S. Appl. No. 13/102,980.
- USPTO; Requirement for Restriction dated Jun. 5, 2014 in U.S. Appl. No. 13/154,271.
- USPTO; Requirement for Restriction dated Apr. 6, 2016 in U.S. Appl. No. 13/166,367.
- USPTO; Advisory Action dated Apr. 21, 2017 in U.S. Appl. No. 13/166,367.
- USPTO; Requirement for Restriction dated Jun. 18, 2014 in U.S. Appl. No. 13/169,951.
- USPTO; Advisory Action dated May 13, 2016 in U.S. Appl. No. 13/169,951.
- USPTO; Advisory Action dated Feb. 15, 2017 in U.S. Appl. No. 13/169,951.
- USPTO; Final Office Action dated Nov. 2, 2017 in U.S. Appl. No. 13/169,951.

(56)

References Cited

OTHER PUBLICATIONS

- USPTO; Advisory Action dated Feb. 8, 2018 in U.S. Appl. No. 13/169,951.
- USPTO; Non-Final Office Action dated Apr. 6, 2018 in U.S. Appl. No. 13/169,951.
- USPTO; Advisory Action dated Dec. 17, 2014 in U.S. Appl. No. 13/181,407.
- USPTO; Requirement for Restriction Sep. 25, 2012 in U.S. Appl. No. 13/184,351.
- USPTO; Advisory Action dated Nov. 7, 2013 in U.S. Appl. No. 13/184,351.
- USPTO; Advisory Action dated May 18, 2015 in U.S. Appl. No. 13/184,351.
- USPTO; Advisory Action dated Oct. 4, 2017 in U.S. Appl. No. 13/184,351.
- USPTO; Non-Final Office Action dated Jul. 26, 2018 in U.S. Appl. No. 13/184,351.
- USPTO; Restriction Requirement dated Aug. 21, 2014 in U.S. Appl. No. 13/187,300.
- USPTO; Advisory Action dated Mar. 28, 2016 in U.S. Appl. No. 13/283,408.
- USPTO; Restriction Requirement dated Oct. 2, 2013 in U.S. Appl. No. 13/312,591.
- USPTO; Advisory Action dated Aug. 26, 2014 in U.S. Appl. No. 13/312,591.
- USPTO; Notice of Allowance dated Jun. 11, 2015 in U.S. Appl. No. 13/312,591.
- USPTO; Requirement for Restriction dated Nov. 26, 2013 in U.S. Appl. No. 13/333,420.
- USPTO; Requirement for Restriction dated Jan. 10, 2013 in U.S. Appl. No. 13/339,609.
- USPTO; Advisory Action dated Mar. 27, 2013 in U.S. Appl. No. 13/406,791.
- USPTO; Advisory Action dated Oct. 29, 2013 in U.S. Appl. No. 13/406,791.
- USPTO; Advisory Action dated Apr. 22, 2015 in U.S. Appl. No. 13/411,271.
- USPTO; Notice of Allowance dated Oct. 21, 2014 in U.S. Appl. No. 13/439,528.
- USPTO; Advisory Action dated Mar. 31, 2014 in U.S. Appl. No. 13/550,419.
- USPTO; Advisory Action dated Apr. 16, 2015 in U.S. Appl. No. 13/563,066.
- USPTO; Non-Final Office Action dated May 28, 2013 in U.S. Appl. No. 13/563,274.
- USPTO; Notice of Allowance dated Sep. 27, 2013 in U.S. Appl. No. 13/563,274.
- USPTO; Advisory Action dated May 5, 2014 in U.S. Appl. No. 13/565,564.
- USPTO; Notice of Allowance dated Sep. 13, 2013 in U.S. Appl. No. 13/566,069.
- USPTO; Advisory Action dated Sep. 2, 2015 in U.S. Appl. No. 13/597,108.
- USPTO; Notice of Allowance dated Mar. 7, 2017 in U.S. Appl. No. 13/597,108.
- USPTO; Restriction Requirement dated Jul. 9, 2013 in U.S. Appl. No. 13/612,538.
- USPTO; Notice of Allowance dated Feb. 25, 2015 in U.S. Appl. No. 13/612,538.
- USPTO; Requirement for Restriction dated Feb. 4, 2015 in U.S. Appl. No. 13/646,403.
- USPTO; Requirement for Restriction dated Apr. 11, 2014 in U.S. Appl. No. 13/646,471.
- USPTO; Advisory Action dated Nov. 14, 2014 in U.S. Appl. No. 13/646,471.
- USPTO; Advisory Action dated Apr. 15, 2016 in U.S. Appl. No. 13/646,471.
- USPTO; Final Office Action dated Oct. 20, 2016 in U.S. Appl. No. 13/646,471.
- USPTO; Restriction Requirement dated Mar. 4, 2015 in U.S. Appl. No. 13/651,144.
- USPTO; Non-Final Office Action dated Dec. 14, 2017 in U.S. Appl. No. 13/651,144.
- USPTO; Advisory Action dated Apr. 19, 2018 in U.S. Appl. No. 13/651,144.
- USPTO; Requirement for Restriction dated Dec. 24, 2014 in U.S. Appl. No. 13/665,366.
- USPTO; Final Office Action dated Mar. 1, 2016 in U.S. Appl. No. 13/665,366.
- USPTO; Advisory Action dated May 13, 2016 in U.S. Appl. No. 13/665,366.
- USPTO; Non-Final Office Action dated Jun. 17, 2016 in U.S. Appl. No. 13/665,366.
- USPTO; Final Office Action dated May 3, 2017 in U.S. Appl. No. 13/665,366.
- USPTO; Notice of Allowance dated Aug. 24, 2015 in U.S. Appl. No. 13/677,133.
- USPTO; Notice of Allowance dated Mar. 17, 2015 in U.S. Appl. No. 13/677,151.
- USPTO; Advisory Action dated Apr. 6, 2016 in U.S. Appl. No. 13/727,324.
- USPTO; Non-Final Office Action dated Sep. 16, 2013 in U.S. Appl. No. 13/760,160.
- USPTO; Final Office Action dated Dec. 27, 2013 in U.S. Appl. No. 13/760,160.
- USPTO; Non-Final Office Action dated Jun. 4, 2014 in U.S. Appl. No. 13/760,160.
- USPTO; Final Office Action dated Sep. 25, 2014 in U.S. Appl. No. 13/760,160.
- USPTO; Final Office Action dated Jan. 28, 2015 in U.S. Appl. No. 13/760,160.
- USPTO; Final Office Action dated May 12, 2015 in U.S. Appl. No. 13/760,160.
- USPTO; Notice of Allowance dated Oct. 21, 2015 in U.S. Appl. No. 13/760,160.
- USPTO; Notice of Allowance dated Jan. 20, 2016 in U.S. Appl. No. 13/760,160.
- USPTO; Advisory Action dated Jul. 13, 2016 in U.S. Appl. No. 13/791,246.
- USPTO; Notice of Allowance dated Oct. 19, 2016 in U.S. Appl. No. 13/791,246.
- USPTO; Advisory Action dated Jul. 14, 2016 in U.S. Appl. No. 13/791,339.
- USPTO; Advisory Action dated Jun. 29, 2015 in U.S. Appl. No. 13/901,372.
- USPTO; Advisory Action dated Dec. 11, 2014 in U.S. Appl. No. 13/912,666.
- USPTO; Requirement for Restriction dated Sep. 4, 2014 in U.S. Appl. No. 13/915,732.
- USPTO; Final Office Action dated Mar. 1, 2016 in U.S. Appl. No. 13/941,216.
- USPTO; Notice of Allowance dated Nov. 14, 2016 in U.S. Appl. No. 13/941,216.
- USPTO; Non-Final Office Action dated Jan. 14, 2014 in U.S. Appl. No. 13/941,226.
- USPTO; Non-Final Office Action dated Jul. 8, 2014 in U.S. Appl. No. 13/941,226.
- USPTO; Non-Final Office Action dated Feb. 3, 2015 in U.S. Appl. No. 13/941,226.
- USPTO; Final Office Action dated Feb. 12, 2016 in U.S. Appl. No. 13/941,226.
- USPTO; Advisory Action dated Jul. 29, 2016 in U.S. Appl. No. 13/941,226.
- USPTO; Non-Final Office Action dated Aug. 8, 2017 in U.S. Appl. No. 13/941,226.
- USPTO; Notice of Allowance dated Feb. 27, 2015 in U.S. Appl. No. 13/948,055.
- USPTO; Notice of Allowance dated Mar. 31, 2015 in U.S. Appl. No. 13/948,055.
- USPTO; Notice of Allowance dated Mar. 21, 2016 in U.S. Appl. No. 13/966,782.

(56)

References Cited

OTHER PUBLICATIONS

USPTO; Non-Final Office Action Restriction dated Jan. 2, 2015 in U.S. Appl. No. 14/040,196.
USPTO; Advisory Action dated Aug. 24, 2015 in U.S. Appl. No. 14/065,114.
USPTO; Non-Final Office Action dated Dec. 23, 2015 in U.S. Appl. No. 14/079,302.
USPTO; Requirement for Restriction dated Aug. 11, 2015 in U.S. Appl. No. 14/090,750.
USPTO; Final Office Action dated Feb. 11, 2016 in U.S. Appl. No. 14/090,750.
USPTO; Advisory Action dated May 5, 2016 in U.S. Appl. No. 14/090,750.
USPTO; Advisory Action dated Dec. 21, 2016 in U.S. Appl. No. 14/090,750.
USPTO; Advisory Action dated Jan. 30, 2018 in U.S. Appl. No. 14/090,750.
USPTO; Non-Final Office Action dated Mar. 12, 2018 in U.S. Appl. No. 14/090,750.
USPTO; Advisory Action dated Feb. 20, 2015 in U.S. Appl. No. 14/183,187.
USPTO; Notice of Allowance dated Aug. 31, 2015 in U.S. Appl. No. 14/183,187.
USPTO; Requirement for Restriction dated Sep. 24, 2015 in U.S. Appl. No. 14/188,760.
USPTO; Non-Final Office Action dated Apr. 18, 2018 in U.S. Appl. No. 14/188,760.
USPTO; Advisory Action dated Apr. 29, 2016 in U.S. Appl. No. 14/218,374.
USPTO; Notice of Allowance dated Aug. 5, 2016 in U.S. Appl. No. 14/218,374.
USPTO; Final Office Action dated May 24, 2018 in U.S. Appl. No. 14/218,690.
USPTO; Advisory Action dated Jun. 30, 2016 in U.S. Appl. No. 14/219,839.
USPTO; Final Office Action dated Jul. 6, 2017 in U.S. Appl. No. 14/219,839.
USPTO; Non-Final Office Action dated Mar. 27, 2018 in U.S. Appl. No. 14/219,839.
USPTO; Final Office action dated May 19, 2016 in U.S. Appl. No. 14/219,879.
USPTO; Advisory Action dated Aug. 22, 2016 in U.S. Appl. No. 14/219,879.
USPTO; Advisory Action dated Oct. 5, 2017 in U.S. Appl. No. 14/219,879.
USPTO; Non-Final Office Action dated Apr. 6, 2018 in U.S. Appl. No. 14/219,879.
USPTO; Advisory Action dated Aug. 2, 2016 in U.S. Appl. No. 14/246,969.
USPTO; Notice of Allowance dated Feb. 27, 2017 in U.S. Appl. No. 14/246,969.
USPTO; Requirement for Restriction dated Jun. 15, 2015 in U.S. Appl. No. 14/268,348.
USPTO; Notice of Allowance dated Aug. 30, 2016 in U.S. Appl. No. 14/268,348.
USPTO; Requirement for Restriction dated May 21, 2015 in U.S. Appl. No. 14/281,477.
USPTO; Advisory Action dated Mar. 28, 2016 in U.S. Appl. No. 14/281,477.
USPTO; Final Office Action dated Mar. 28, 2018 in U.S. Appl. No. 14/444,744.
USPTO; Non-Final Office Action dated Jul. 27, 2018 in U.S. Appl. No. 14/444,744.
USPTO; Notice of Allowance dated Nov. 28, 2016 in U.S. Appl. No. 14/449,838.
USPTO; Advisory Action dated Sep. 21, 2016 in U.S. Appl. No. 14/457,058.
USPTO; Non-Final Office Action dated Oct. 19, 2017 in U.S. Appl. No. 14/457,058.

USPTO; Final Office Action dated Jun. 14, 2018 in U.S. Appl. No. 14/457,058.
USPTO; Non-Final Office Action dated May 31, 2018 in U.S. Appl. No. 15/491,726.
USPTO; Requirement for Restriction dated Sep. 3, 2015 in U.S. Appl. No. 14/498,036.
USPTO; Advisory Action dated Jun. 16, 2016 in U.S. Appl. No. 14/498,036.
USPTO; Notice of Allowance dated Aug. 17, 2016 in U.S. Appl. No. 14/498,036.
USPTO; Requirement for Restriction dated Mar. 20, 2015 in U.S. Appl. No. 14/505,290.
USPTO; Advisory Action dated Aug. 17, 2016 in U.S. Appl. No. 14/508,296.
USPTO; Notice of Allowance dated Jan. 27, 2017 in U.S. Appl. No. 14/508,296.
USPTO; Restriction for Requirement dated Dec. 30, 2016 in U.S. Appl. No. 14/508,489.
USPTO; Non-Final Office Action dated May 15, 2018 in U.S. Appl. No. 14/508,489.
USPTO; Advisory Action dated Dec. 21, 2016 in U.S. Appl. No. 14/568,647.
USPTO; Advisory Action dated Apr. 12, 2018 in U.S. Appl. No. 14/568,647.
USPTO; Non-Final Office Action dated May 25, 2018 in U.S. Appl. No. 14/568,647.
USPTO; Notice of Allowance dated May 18, 2016 in U.S. Appl. No. 14/571,126.
USPTO; Restriction Requirement dated Mar. 7, 2016 in U.S. Appl. No. 14/606,364.
USPTO; Final Office Action dated Jun. 14, 2016 in U.S. Appl. No. 14/606,364.
USPTO; Advisory Action dated Aug. 25, 2016 in U.S. Appl. No. 14/606,364.
USPTO; Non-Final Office Action dated Sep. 27, 2016 in U.S. Appl. No. 14/606,354.
USPTO; Notice of Allowance dated Aug. 2, 2016 in U.S. Appl. No. 14/622,603.
USPTO; Notice of Allowance dated Feb. 16, 2016 in U.S. Appl. No. 14/634,342.
USPTO; Non-Final Office Action dated May 16, 2018 in U.S. Appl. No. 14/645,234.
USPTO; Final Office Action dated Aug. 10, 2018 in U.S. Appl. No. 14/645,234.
USPTO; Non-Final Office Action dated Apr. 6, 2018 in U.S. Appl. No. 14/656,588.
USPTO; Requirement for Restriction dated Oct. 26, 2015 in U.S. Appl. No. 14/659,152.
USPTO; Non-Final Office Action dated Sep. 7, 2017 in U.S. Appl. No. 14/660,755.
USPTO; Requirement for Restriction dated Jul. 5, 2017 in U.S. Appl. No. 14/752,712.
USPTO; Advisory Action dated Feb. 15, 2018 in U.S. Appl. No. 14/752,712.
USPTO; Non-Final Office Action dated Mar. 21, 2018 in U.S. Appl. No. 14/752,712.
USPTO; Final Office Action dated Mar. 29, 2018 in U.S. Appl. No. 14/793,323.
USPTO; Non-Final Office Action dated Aug. 10, 2018 in U.S. Appl. No. 14/793,323.
USPTO; Non-Final Office Action dated Sep. 21, 2017 in U.S. Appl. No. 14/808,979.
USPTO; Final Office Action dated Mar. 14, 2018 in U.S. Appl. No. 14/808,979.
USPTO; Notice of Allowance dated Jun. 27, 2018 in U.S. Appl. No. 14/808,979.
USPTO; Non-Final Office Action dated Feb. 23, 2018 in U.S. Appl. No. 14/817,953.
USPTO; Notice of Allowance dated Jul. 11, 2018 in U.S. Appl. No. 14/817,953.
USPTO; Requirement for Restriction dated Mar. 17, 2016 in U.S. Appl. No. 14/827,177.

(56)

References Cited

OTHER PUBLICATIONS

- USPTO; Notice of Allowance dated Jan. 27, 2017 in U.S. Appl. No. 14/827,177.
- USPTO; Requirement for Restriction dated Aug. 8, 2016 in U.S. Appl. No. 14/829,565.
- USPTO; Advisory Action dated Apr. 20, 2017 in U.S. Appl. No. 14/829,565.
- USPTO; Final Office Action dated Mar. 5, 2018 in U.S. Appl. No. 14/829,565.
- USPTO; Advisory Action dated Feb. 14, 2017 in U.S. Appl. No. 14/835,637.
- USPTO; Advisory Action dated Apr. 20, 2017 in U.S. Appl. No. 14/884,695.
- USPTO; Requirement for Restriction dated Dec. 1, 2016 in U.S. Appl. No. 14/886,571.
- USPTO; Requirement for Restriction dated Sep. 20, 2016 in U.S. Appl. No. 14/919,536.
- USPTO; Final Office Action dated May 11, 2018 in U.S. Appl. No. 14/919,536.
- USPTO; Non-Final Office Action dated May 3, 2016 in U.S. Appl. No. 14/937,053.
- USPTO; Notice of Allowance dated Jul. 26, 2016 in U.S. Appl. No. 14/937,053.
- USPTO; Requirement for Restriction dated Sep. 15, 2016 in U.S. Appl. No. 14/938,180.
- USPTO; Notice of Allowance dated Nov. 21, 2016 in U.S. Appl. No. 14/981,434.
- USPTO; Final Office Action dated Feb. 6, 2018 in U.S. Appl. No. 14/997,683.
- USPTO; Advisory Action dated May 2, 2018 in U.S. Appl. No. 14/997,683.
- USPTO; Non-Final Office Action dated Jun. 20, 2018 in U.S. Appl. No. 14/997,683.
- USPTO; Requirement for Restriction dated Apr. 19, 2017 in U.S. Appl. No. 15/050,159.
- USPTO; Notice of Allowance dated Feb. 7, 2018 in U.S. Appl. No. 15/050,159.
- USPTO; Non-Final Office Action dated Apr. 22, 2016 in U.S. Appl. No. 15/055,122.
- USPTO; Notice of Allowance dated Sep. 15, 2016 in U.S. Appl. No. 15/055,122.
- USPTO; Non-Final Office Action dated Feb. 20, 2018 in U.S. Appl. No. 15/060,412.
- USPTO; Requirement for Restriction dated Jun. 4, 2018 in U.S. Appl. No. 15/067,028.
- USPTO; Requirement for Restriction dated Jun. 28, 2018 in U.S. Appl. No. 15/074,813.
- USPTO; Notice of Allowance dated Jun. 29, 2018 in U.S. Appl. No. 15/135,224.
- USPTO; Final Office Action dated Jul. 6, 2018 in U.S. Appl. No. 15/135,258.
- USPTO; Notice of Allowance dated Apr. 11, 2018 in U.S. Appl. No. 15/144,481.
- USPTO; Final Office Action dated Jul. 26, 2018 in U.S. Appl. No. 15/144,506.
- USPTO; Requirement for Restriction dated Jun. 22, 2018 in U.S. Appl. No. 15/182,504.
- USPTO; Final Office Action dated Jun. 7, 2017 in U.S. Appl. No. 15/203,632.
- USPTO; Advisory Action dated Aug. 23, 2017 in U.S. Appl. No. 15/203,632.
- USPTO; Advisory Action dated Jun. 22, 2017 in U.S. Appl. No. 15/203,642.
- USPTO; Non-Final Office Action dated May 14, 2018 in U.S. Appl. No. 15/205,827.
- USPTO; Requirement for Restriction dated Jan. 26, 2017 in U.S. Appl. No. 15/205,890.
- USPTO; Non-Final Office Action dated Jan. 20, 2017 in U.S. Appl. No. 15/210,256.
- USPTO; Notice of Allowance dated May 18, 2017 in U.S. Appl. No. 15/210,256.
- USPTO; Notice of Allowance dated Jul. 24, 2017 in U.S. Appl. No. 15/210,256.
- USPTO; Requirement for Restriction dated Apr. 3, 2017 in U.S. Appl. No. 15/222,715.
- USPTO; Notice of Allowance dated Feb. 3, 2017 in U.S. Appl. No. 15/222,738.
- USPTO; Final Office Action dated Jun. 4, 2018 in U.S. Appl. No. 15/222,749.
- USPTO; Final Office Action dated May 17, 2018 in U.S. Appl. No. 15/222,780.
- USPTO; Requirement for Restriction dated Dec. 5, 2017 in U.S. Appl. No. 15/254,605.
- USPTO; Notice of Allowance dated Jul. 12, 2018 in U.S. Appl. No. 15/254,605.
- USPTO; Notice of Allowance dated Apr. 2, 2018 in U.S. Appl. No. 15/254,724.
- USPTO; Non-Final Office Action dated May 22, 2018 in U.S. Appl. No. 15/262,990.
- USPTO; Non-Final Office Action dated Aug. 3, 2018 in U.S. Appl. No. 15/273,488.
- USPTO; Non-Final Office Action dated Jul. 2, 2018 in U.S. Appl. No. 15/286,503.
- USPTO; Requirement for Restriction dated Sep. 12, 2017 in U.S. Appl. No. 15/377,439.
- USPTO; Final Office Action dated Apr. 16, 2018 in U.S. Appl. No. 15/377,439.
- USPTO; Advisory Action dated Aug. 8, 2018 in U.S. Appl. No. 15/377,439.
- USPTO; Notice of Allowance dated Aug. 8, 2017 in U.S. Appl. No. 15/380,895.
- USPTO; Requirement for Restriction dated Sep. 21, 2017 in U.S. Appl. No. 15/380,921.
- USPTO; Final Office Action dated Jun. 28, 2018 in U.S. Appl. No. 15/380,921.
- USPTO; Final Office Action dated May 15, 2018 in U.S. Appl. No. 15/388,410.
- USPTO; Non-Final Office Action dated Aug. 7, 2018 in U.S. Appl. No. 15/428,808.
- USPTO; Non-Final Office Action dated Apr. 6, 2018 in U.S. Appl. No. 15/434,051.
- USPTO; Notice of Allowance dated Apr. 20, 2018 in U.S. Appl. No. 15/466,149.
- USPTO; Final Office Action dated Apr. 19, 2018 in U.S. Appl. No. 15/489,453.
- USPTO; Notice of Allowance dated Dec. 19, 2017 in U.S. Appl. No. 15/489,660.
- USPTO; Non-Final Office Action dated Apr. 6, 2018 in U.S. Appl. No. 15/472,750.
- USPTO; Notice of Allowance dated Mar. 21, 2018 in U.S. Appl. No. 15/476,035.
- USPTO; Notice of Allowance dated Aug. 14, 2018 in U.S. Appl. No. 15/476,035.
- USPTO; Notice of Allowance dated May 23, 2018 in U.S. Appl. No. 15/499,647.
- USPTO; Non-Final Office Action dated Jun. 21, 2018 in U.S. Appl. No. 15/499,647.
- USPTO; Office Action dated May 3, 2018 in U.S. Appl. No. 15/589,861.
- USPTO; Requirement of Restriction dated Mar. 30, 2018 in U.S. Appl. No. 15/589,849.
- USPTO; Office Action dated Aug. 30, 2018 in U.S. Appl. No. 15/589,849.
- USPTO; Non-Final Office Action dated Apr. 4, 2018 in U.S. Appl. No. 15/592,730.
- USPTO; Requirement for Restriction dated Aug. 1, 2018 in U.S. Appl. No. 15/627,189.
- USPTO; Non-Final Office Action dated Jun. 5, 2018 in U.S. Appl. No. 15/650,686.
- USPTO; Requirement for Restriction dated Apr. 6, 2018 in U.S. Appl. No. 15/659,631.

(56)

References Cited

OTHER PUBLICATIONS

- USPTO; Non-Final Office Action dated Aug. 9, 2018 in U.S. Appl. No. 15/660,805.
- USPTO; Non-Final Office Action dated Jul. 27, 2018 in U.S. Appl. No. 15/673,110.
- USPTO; Non-Final Office Action dated Apr. 25, 2018 in U.S. Appl. No. 15/673,278.
- USPTO; Non-Final Office Action dated Jan. 18, 2018 in U.S. Appl. No. 15/683,701.
- USPTO; Final Office Action dated Aug. 24, 2018 in U.S. Appl. No. 15/683,701.
- USPTO; Non-Final Office Action dated Aug. 9, 2018 in U.S. Appl. No. 15/691,241.
- USPTO; Requirement for Restriction dated Jul. 11, 2018 in U.S. Appl. No. 15/707,786.
- USPTO; Requirement for Restriction dated May 11, 2018 in U.S. Appl. No. 15/711,989.
- USPTO; Non-Final Office Action dated Jun. 14, 2018 in U.S. Appl. No. 15/711,989.
- USPTO; Non-Final Office Action dated May 29, 2018 in U.S. Appl. No. 15/719,208.
- USPTO; Non-Final Office Action dated Apr. 19, 2018 in U.S. Appl. No. 15/726,959.
- USPTO; Non-Final Office Action dated May 17, 2018 in U.S. Appl. No. 15/729,485.
- USPTO; Non-Final Office Action dated Jun. 26, 2018 in U.S. Appl. No. 15/796,593.
- USPTO; Notice of Allowance dated Jun. 13, 2018 in U.S. Appl. No. 15/798,120.
- USPTO; Requirement for Restriction dated Apr. 6, 2018 in U.S. Appl. No. 15/798,201.
- USPTO; Non-Final Office Action dated Aug. 9, 2018 in U.S. Appl. No. 15/798,201.
- USPTO; Non-Final Office Action dated Jul. 2, 2018 in U.S. Appl. No. 15/815,483.
- USPTO; Requirement for Restriction dated Mar. 21, 2018 in U.S. Appl. No. 15/863,340.
- USPTO; Non-Final Office Action dated Jul. 23, 2018 in U.S. Appl. No. 15/863,340.
- USPTO; Notice of Allowance dated May 14, 2012 in U.S. Appl. No. 29/411,637.
- USPTO; Notice of Allowance dated Oct. 2, 2013 in U.S. Appl. No. 29/412,887.
- USPTO; Notice of Allowance dated Dec. 19, 2013 in U.S. Appl. No. 29/448,094.
- USPTO; Requirement for Restriction dated Dec. 1, 2014 in U.S. Appl. No. 29/481,312.
- USPTO; Requirement for Restriction dated Dec. 4, 2014 in U.S. Appl. No. 29/481,315.
- USPTO; Notice of Allowance dated Jun. 16, 2017 in U.S. Appl. No. 29/570,711.
- USPTO; Notice of Allowance dated Jun. 26, 2018 in U.S. Appl. No. 29/604,288.
- PCT; International Preliminary Report on Patentability dated Nov. 24, 2009 and International Search Report dated Jul. 31, 2008 in Application No. PCT/US2008/063919.
- PCT; International Preliminary Report on Patentability dated Feb. 24, 2010 in Application No. PCT/US2008/074063.
- PCT; International Preliminary Report on Patentability dated Nov. 26, 2009 in Application No. PCT/US2009/043454.
- PCT; International Preliminary Report on Patentability dated Jun. 14, 2011 in Application No. PCT/US2009/066377.
- PCT; International Preliminary Report on Patentability dated Nov. 9, 2011 in Application No. PCT/US2010/033244.
- PCT; International Preliminary Report on Patentability dated Nov. 9, 2011 in Application No. PCT/US2010/033248.
- PCT; International Preliminary Report on Patentability dated Nov. 9, 2011 in Application No. PCT/US2010/033252.
- PCT; International Search Report and Written Opinion dated Nov. 16, 2017 in Application No. PCT/IB2017/001015.
- PCT; International Search Report and Written Opinion dated Nov. 13, 2017 in Application No. PCT/IB2017/001050.
- PCT; International Search Report and Written Opinion dated Nov. 30, 2017 in Application No. PCT/IB2017/001070.
- PCT; International Search Report and Written Opinion dated Jan. 25, 2018 in Application No. PCT/IB2017/001262.
- PCT; International Search Report and Written Opinion dated Jun. 1, 2018 in Application No. PCT/IB2017/001644.
- PCT; International Search Report and Written Opinion dated Jun. 1, 2018 in Application No. PCT/IB2017/001656.
- Chinese Patent Office; Office Action dated Aug. 1, 2013 in Application No. 201080015699.9.
- Chinese Patent Office; Office Action dated Jan. 21, 2014 in Application No. 201080015699.9.
- Chinese Patent Office; Office Action dated Jul. 24, 2014 in Application No. 201080015699.9.
- Chinese Patent Office; Office Action dated Dec. 10, 2013 in Application No. 201080020267.7.
- Chinese Patent Office; Office Action dated Jan. 21, 2013 in Application No. 201080020268.1.
- Chinese Patent Office; Office Action dated Sep. 26, 2013 in Application No. 201080020268.1.
- Chinese Patent Office; Office Action dated Apr. 3, 2014 in Application No. 201080020268.1.
- Chinese Patent Office; Office Action dated Sep. 23, 2014 in Application No. 201080020268.1.
- Chinese Patent Office; Office Action dated Apr. 7, 2015 in Application No. 201080020268.1.
- Chinese Patent Office; Office Action dated Dec. 4, 2015 in Application No. 201210201995.9.
- Chinese Patent Office; Office Action dated Jul. 14, 2016 in Application No. 201210201995.9.
- Chinese Patent Office; Office Action dated Jan. 20, 2017 in Application No. 201210201995.9.
- Chinese Patent Office; Office Action dated Dec. 24, 2015 in Application No. 201280057466.4.
- Chinese Patent Office; Office Action dated Dec. 4, 2015 in Application No. 201280057542.1.
- Chinese Patent Office; Office Action dated May 16, 2016 in Application No. 201280057542.1.
- Chinese Patent Office; Office Action dated Sep. 9, 2016 in Application No. 201280057542.1.
- Chinese Patent Office; Office Action dated Dec. 5, 2016 in Application No. 201310412808.6.
- Chinese Patent Office; Office Action dated Feb. 5, 2018 in Application No. 201410331047.6.
- European Patent Office; Supplementary European Search Report and Opinion dated Nov. 9, 2012 in Application No. 08798519.8.
- European Patent Office; Office Action dated Jul. 18, 2016 in Application No. 08798519.8.
- European Patent Office; Extended European Search Report dated Dec. 9, 2016 in Application No. 9767208.3.
- European Patent Office; Supplementary European Search Report and Opinion dated Jan. 5, 2017 in Application No. 09836647.9.
- European Patent Office; Office Action dated Feb. 28, 2018 in Application No. 09836647.9.
- Japanese Patent Office; Office Action dated Dec. 20, 2011 in Application No. 2010-522075.
- Japanese Patent Office; Office Action dated Apr. 11, 2012 in Application No. 2010-522075.
- Japanese Patent Office; Office Action dated May 31, 2012 in Application No. 2011-514650.
- Japanese Patent Office; Office Action dated Sep. 11, 2012 in Application No. 2011-514650.
- Japanese Patent Office; Office Action dated Dec. 25, 2013 in Application No. 2012-504786.
- Japanese Patent Office; Office Action dated Mar. 11, 2013 in Application No. 2012-509857.
- Korean Patent Office; Final Office Action dated Jun. 29, 2016 in Application No. 10-2010-0028336.
- Korean Patent Office; Office Action dated Mar. 3, 2016 in Application No. 10-2010-0067768.

(56)

References Cited

OTHER PUBLICATIONS

- Korean Patent Office; Office Action dated Aug. 1, 2016 in Application No. 10-2010-0067768.
- Korean Patent Office; Office Action dated May 2, 2016 in Application No. 10-2010-0082446.
- Korean Patent Office; Office Action dated Sep. 19, 2016 in Application No. 10-2010-0082446.
- Korean Patent Office; Office Action dated Nov. 24, 2017 in Application No. 10-20110036449.
- Korean Patent Office; Office Action dated May 23, 2017 in Application No. 10-20110036449.
- Korean Patent Office; Office Action dated Sep. 4, 2017 in Application No. 10-2011-0087600.
- Korean Patent Office; Office Action dated Oct. 23, 2017 in Application No. 10-2011-0142924.
- Korean Patent Office; Office Action dated Dec. 11, 2015 in Application No. 10-20117023416.
- Korean Patent Office; Office Action dated Mar. 13, 2016 in Application No. 10-20117023416.
- Korean Patent Office; Office Action dated Oct. 30, 2017 in Application No. 10-2012-0041878.
- Korean Patent Office; Office Action dated Mar. 21, 2018 in Application No. 20120042518.
- Korean Patent Office; Office Action dated Mar. 21, 2018 in Application No. 10-2012-0064526.
- Korean Patent Office; Office Action dated Mar. 30, 2018 in Application No. 10-2012-0076564.
- Korean Patent Office; Office Action dated Apr. 30, 2018 in Application No. 10-2012-0103114.
- Korean Patent Office; Office Action dated Oct. 24, 2016 in Application No. 10-20127004062.
- Korean Patent Office; Office Action dated Jul. 24, 2017 in Application No. 10-20127004062.
- Korean Patent Office; Office Action dated Sep. 28, 2017 in Application No. 10-20147017112.
- Korean Patent Office; Office Action dated Nov. 9, 2016 in Application No. 10-20167023913.
- Korean Patent Office; Office Action dated Sep. 15, 2017 in Application No. 30-2017-0001320.
- Korean Patent Office; Office Action dated Jul. 11, 2018 in Application No. 30-2018-006016.
- Taiwanese Patent Office; Office Action dated Aug. 30, 2013 in Application No. 97132391.
- Taiwanese Patent Office; Office Action dated Dec. 20, 2013 in Application No. 98117513.
- Taiwanese Patent Office; Office Action dated Aug. 27, 2014 in Application No. 99114329.
- Taiwanese Patent Office; Office Action dated Dec. 26, 2014 in Application No. 99114330.
- Taiwanese Patent Office; Office Action dated Aug. 14, 2014 in Application No. 99114331.
- Taiwanese Patent Office; Office Action received in Application No. 100113130.
- Taiwanese Patent Office; Office Action dated Aug. 1, 2016 in Application No. 101124745.
- Taiwanese Patent Office; Office Action received in Application No. 102113028.
- Taiwanese Patent Office; Office Action received in Application No. 102115605.
- Taiwanese Patent Office; Office Action dated Feb. 24, 2017 in Application No. 102115605.
- Taiwanese Patent Office; Office Action received in Application No. 102125191.
- Taiwanese Patent Office; Office Action dated Dec. 6, 2016 in Application No. 102126071.
- Taiwanese Patent Office; Office Action dated May 17, 2018 in Application No. 102126071.
- Taiwanese Patent Office; Office Action dated Feb. 10, 2017 in Application No. 102127065.
- Taiwanese Patent Office; Office Action dated Mar. 11, 2016 in Application No. 102129262.
- Taiwanese Patent Office; Office Action dated Dec. 29, 2016 in Application No. 102129397.
- Taiwanese Patent Office; Office Action dated Nov. 4, 2016 in Application No. 102131839.
- Taiwanese Patent Office; Office Action dated Dec. 2, 2016 in Application No. 102136496.
- Taiwanese Patent Office; Office Action dated Jan. 10, 2018 in Application No. 102136496.
- Taiwanese Patent Office; Office Action dated Nov. 11, 2016 in Application No. 102132952.
- Taiwanese Patent Office; Office Action dated Jul. 17, 2017 in Application No. 103101400.
- Taiwanese Patent Office; Office Action dated Feb. 23, 2017 in Application No. 103102563.
- Taiwanese Patent Office; Office Action dated Mar. 3, 2017 in Application No. 103105251.
- Taiwanese Patent Office; Office Action received in Application No. 103106021.
- Taiwanese Patent Office; Office Action dated Oct. 31, 2017 in Application No. 103106022.
- Taiwanese Patent Office; Office Action dated Jul. 5, 2017 in Application No. 103117477.
- Taiwanese Patent Office; Office Action dated Nov. 22, 2017 in Application No. 103117478.
- Taiwanese Patent Office; Office Action dated May 19, 2017 in Application No. 103120478.
- Taiwanese Patent Office; Office Action dated Nov. 8, 2017 in Application No. 103124509.
- Taiwanese Patent Office; Office Action dated Nov. 20, 2017 in Application No. 103127588.
- Taiwanese Patent Office; Office Action dated Sep. 19, 2017 in Application No. 103127734.
- Taiwanese Patent Office; Office Action dated Nov. 22, 2017 in Application No. 103134537.
- Taiwanese Patent Office; Office Action dated Aug. 24, 2017 in Application No. 103136251.
- Taiwanese Patent Office; Office Action dated Feb. 26, 2018 in Application No. 103138510.
- Taiwanese Patent Office; Office Action dated Jun. 22, 2018 in Application No. 104105533.
- Taiwanese Patent Office; Office Action dated Jun. 13, 2018 in Application No. 104111910.
- Taiwanese Patent Office; Office Action received in Application No. 106117181.
- Choi et al., "Improvement of Silicon Direct Bonding using Surfaces Activated by Hydrogen Plasma Treatment," *Journal of the Korean Physical Society*, 37, 6, 878-881 (2000).
- Elam et al., "New Insights into Sequential Infiltration Synthesis", *ECS Transactions*, vol. 69, pp. 147-157 (2015).
- Guan et al., "Voltage gated ion and molecule transport in engineered nanochannels: theory, fabrication and applications," *Nanotechnology* 25 (2014) 122001.
- Henke et al., "X-Ray Interactions: Photo absorption, Scattering, Transmission, and Reflection at E=50-30,000 eV, Z=1-92," *Atomic Data and Nuclear Data Tables*, 54, 181-342 (1993).
- Hudis, "Surface Crosslinking of Polyethylene Using a Hydrogen Glow Discharge," *J. Appl. Polym. Sci.*, 16 (1972) 2397.
- Jones et al., "Growth of Aluminum Films by Low Pressure Chemical Vapour Deposition Using Tertiarybutylaluminium," *Journal of Crystal Growth* 135, pp. 285-289, Elsevier Science B.V. (1994).
- Kim et al., "Characteristics of Low Temperature High Quality Silicon Oxide by Plasma Enhanced Atomic Layer Deposition with In-Situ Plasma Densification Process," *The Electrochemical Society, ECS Transactions*, College of Information and Communication Engineering, Sungkyunkwan University, 53(1), 321-329 (2013).
- Klug et al., "Atomic Layer Deposition of Amorphous Niobium Carbide-Based Thin Film Superconductors," *The Journal of Physical Chemistry C*, vol. 115, pp. 25063-25071, (2011).
- Knoops et al., "Atomic Layer Deposition of Silicon Nitride from Bis(tert-butyloamino) silane and N₂ Plasma," *Applied Materials & Interfaces*, American Chemical Society, A-E (2015).

(56)

References Cited

OTHER PUBLICATIONS

- Liu et al., "Research, Design, and Experiment of End Effector for Wafer Transfer Robot," *Industrial Robot: An International Journal*, 79-91 (2012).
- Longrie et al., "Plasma-Enhanced ALD of Platinum with O₂, N₂ and NH₃ Plasmas", *ECS Journal of Solid State Science and Technology*, vol. 1, pp. Q123-Q129 (2012).
- Marsik et al., "Effect of Ultraviolet Curing Wavelength on Low-k Dielectric Material Properties and Plasma Damage Resistance," *Scencedirect.com*, 519, 11, 3619-3626 (2011).
- Maydannik et al., "Spatial atomic layer deposition: Performance of low temperature H₂O and O₃ oxidant chemistry for flexible electronics encapsulation", *Journal of Vacuum Science and Technology: Part A AVS/ AIP*, vol. 33 (1901).
- Mix et al., "Characterization of plasma-polymerized allyl alcohol polymers and copolymers with styrene," *Adhes. Sci. Technol.*, 21 (2007), S. 487-507.
- Potts et al., "Room-Temperature ALD of Metal Oxide Thin Films by Energy-Enhanced ALD", *Chemical Vapor Deposition*, vol. 19, pp. 125-133 (2013).
- Provine et al., "Correlation of Film Density and Wet Etch Rate in Hydrofluoric Acid of Plasma Enhanced Atomic Layer Deposited Silicon Nitride," *AIP Advances*, 6 (2016).
- Selvaraj et al., "Selective Atomic Layer Deposition of Zirconia on Copper Patterned Silicon Substrates Using Ethanol as Oxygen Source as Well as Copper Reductant," *J. Vac. Sci. Technol. A32(1)*, (2014).
- Selvaraj et al., "Surface Selective Atomic Layer Deposition of Hafnium Oxide for Copper Diffusion Barrier Application Using Tetrakis (diethylamino) Hafnium and Ethanol," 225th ECS Meeting, Meeting Abstract, (May 12, 2014).
- Tseng et al., "Etch Properties of Resists Modified by Sequential Infiltration Synthesis," *American Vacuum Society* (2011).
- Tseng et al., "Enhanced Block Copolymer Lithography Using Sequential Infiltration Synthesis," *Journal of Physical Chemistry*, vol. 5, 17725-17729 (2011).
- Voltaix, "Material Safety Data Sheet for: Trisilylamine", pp. 1-8, (2014).
- CNIPA; Notice of Allowance dated Sep. 3, 2019 in Application No. 201610141027.1.
- CNIPA; Notice of Allowance dated Sep. 30, 2010 in Application No. 201510765170.3.
- CNIPA; Office Action dated Jul. 23, 2019 in Application No. 201610897958.4.
- EPO; Notice of Allowance dated Aug. 1, 2019 in Application No. 09767208.3.
- JPO; Office Action dated Aug. 29, 2019 in Application No. 2016001928.
- KIPO; Notice of Allowance dated Jul. 5, 2019 in Application No. 10-2012-0064526.
- KIPO; Notice of Allowance dated Aug. 29, 2019 in Application No. 10-2013-0036823.
- KIPO; Office Action dated Aug. 27, 2019 in Application No. 10-2013-0049598.
- KIPO; Office Action dated Aug. 27, 2019 in Application No. 10-2013-0089998.
- KIPO; Notice of Allowance dated Oct. 8, 2019 in Application No. 10-2013-0101944.
- KIPO; Office Action dated Aug. 15, 2019 in Application No. 10-2013-0109390.
- KIPO; Office Action dated Oct. 7, 2019 in Application No. 10-2013-0114079.
- KIPO; Notice of Allowance dated Aug. 26, 2019 in Application No. 10-2014-7017110.
- KIPO; Final Office Action dated Jun. 17, 2019 in Application No. 10-2017-7023740.
- TIPO; Office Action dated Aug. 16, 2019 in Application No. 102136496.
- TIPO; Notice of Allowance dated Jul. 10, 2019 in Application No. 103123439.
- TIPO; Notice of Allowance dated Sep. 27, 2019 in Application No. 104105533.
- TIPO; Notice of Allowance dated Sep. 23, 2019 in Application No. 104105965.
- TIPO; Notice of Allowance dated Oct. 4, 2019 in Application No. 104122889.
- TIPO; Notice of Allowance dated Jul. 19, 2019 in Application No. 104122890.
- TIPO; Office Action dated Jul. 5, 2019 in Application No. 105112363.
- TIPO; Office Action dated Sep. 9, 2019 in Application No. 105115513.
- TIPO; Notice of Allowance dated Sep. 20, 2019 in Application No. 106138800.
- TIPO; Office Action dated Aug. 27, 2019 in Application No. 107116804.
- TIPO; Office Action dated Jun. 28, 2019 in Application No. 108102948.
- USPTO; Non-Final Office Action dated Aug. 19, 2019 in U.S. Appl. No. 13/184,351.
- USPTO; Advisory Action dated Feb. 12, 2016 in U.S. Appl. No. 13/651,144.
- USPTO; Advisory Action dated Dec. 29, 2016 in U.S. Appl. No. 13/651,144.
- USPTO; Non-Final Office Action dated Sep. 18, 2019 in U.S. Appl. No. 13/651,144.
- USPTO; Advisory Action dated Jun. 26, 2015 in U.S. Appl. No. 13/791,246.
- USPTO; Notice of Allowance dated Apr. 22, 2016 in U.S. Appl. No. 14/172,220.
- USPTO; Non-Final Office Action dated Aug. 8, 2019 in U.S. Appl. No. 14/188,760.
- USPTO; Advisory Action dated Jan. 22, 2019 in U.S. Appl. No. 14/219,839.
- USPTO; Notice of Allowance dated Aug. 19, 2016 in U.S. Appl. No. 14/268,348.
- USPTO; Non-Final Office Action dated Aug. 8, 2019 in U.S. Appl. No. 14/444,744.
- USPTO; Advisory Action dated Nov. 6, 2015 in U.S. Appl. No. 14/457,058.
- USPTO; Notice of Allowance dated Aug. 16, 2017 in U.S. Appl. No. 14/606,364.
- USPTO; Notice of Allowance dated Aug. 15, 2019 in U.S. Appl. No. 14/645,234.
- USPTO; Non-Final Office Action dated Sep. 19, 2019 in U.S. Appl. No. 14/829,565.
- USPTO; Final Office Action dated Jun. 10, 2016 in U.S. Appl. No. 14/987,420.
- USPTO; Notice of Allowance dated Mar. 26, 2018 in U.S. Appl. No. 15/144,481.
- USPTO; Final Office Action dated Aug. 9, 2019 in U.S. Appl. No. 15/205,827.
- USPTO; Non-Final Office Action dated Aug. 5, 2019 in U.S. Appl. No. 15/262,990.
- USPTO; Advisory Action dated Jul. 29, 2019 in U.S. Appl. No. 15/402,993.
- USPTO; Notice of Allowance dated Aug. 14, 2019 in U.S. Appl. No. 15/410,503.
- USPTO; Final Office Action dated Aug. 20, 2019 in U.S. Appl. No. 14/508,489.
- USPTO; Notice of Allowance dated Aug. 21, 2019 in U.S. Appl. No. 15/592,730.
- USPTO; Notice of Allowance dated Sep. 11, 2019 in U.S. Appl. No. 15/598,169.
- USPTO; Non-Final Office Action dated Sep. 4, 2019 in U.S. Appl. No. 15/615,489.
- USPTO; Non-Final Office Action dated Jul. 29, 2019 in U.S. Appl. No. 15/660,797.
- USPTO; Notice of Allowance dated Aug. 22, 2019 in U.S. Appl. No. 15/660,805.
- USPTO; Final Office Action dated Jul. 26, 2019 in U.S. Appl. No. 15/690,017.
- USPTO; Final Office Action dated Aug. 12, 2019 in U.S. Appl. No. 15/707,786.
- USPTO; Non-Final Office Action dated Jul. 8, 2019 in U.S. Appl. No. 15/726,959.

(56)

References Cited

OTHER PUBLICATIONS

- USPTO; Final Office Action dated Jul. 31, 2019 in U.S. Appl. No. 15/795,056.
- USPTO; Non-Final Office Action dated Oct. 2, 2019 in U.S. Appl. No. 15/798,201.
- USPTO; Non-Final Office Action dated Aug. 20, 2019 in U.S. Appl. No. 15/815,483.
- USPTO; Notice of Allowance dated Aug. 16, 2019 in U.S. Appl. No. 15/836,547.
- USPTO; Non-Final Office Action dated Jul. 31, 2019 in U.S. Appl. No. 15/860,564.
- USPTO; Final Office Action dated Aug. 21, 2019 in U.S. Appl. No. 15/879,209.
- USPTO; Notice of Allowance dated Sep. 23, 2019 in U.S. Appl. No. 15/886,225.
- USPTO; Non-Final Office Action dated Sep. 19, 2019 in U.S. Appl. No. 15/897,578.
- USPTO; Final Office Action dated Aug. 28, 2019 in U.S. Appl. No. 15/917,224.
- USPTO; Notice of Allowance dated Aug. 30, 2019 in U.S. Appl. No. 15/917,262.
- USPTO; Non-Final Office Action dated Jul. 22, 2019 in U.S. Appl. No. 15/940,759.
- USPTO; Notice of Allowance dated Aug. 26, 2019 in U.S. Appl. No. 15/940,801.
- USPTO; Notice of Allowance dated Aug. 22, 2019 in U.S. Appl. No. 15/985,298.
- USPTO; Notice of Allowance dated Jul. 31, 2019 in U.S. Appl. No. 15/987,755.
- USPTO; Non-Final Office Action dated Jul. 29, 2019 in U.S. Appl. No. 16/000,125.
- USPTO; Final Office Action dated Aug. 23, 2019 in U.S. Appl. No. 16/018,692.
- USPTO; Non-Final Office Action dated Aug. 7, 2019 in U.S. Appl. No. 16/024,390.
- USPTO; Notice of Allowance dated Jul. 10, 2019 in U.S. Appl. No. 16/046,218.
- USPTO; Final Office Action dated Sep. 25, 2019 in U.S. Appl. No. 16/147,047.
- USPTO; Non-Final Office Action dated Aug. 6, 2019 in U.S. Appl. No. 16/158,077.
- USPTO; Final Office Action dated Sep. 26, 2019 in U.S. Appl. No. 16/188,690.
- USPTO; Non-Final Office Action dated Aug. 29, 2019 in U.S. Appl. No. 16/161,744.
- USPTO; Non-Final Office Action dated Aug. 16, 2019 in U.S. Appl. No. 16/167,225.
- USPTO; Non-Final Office Action dated Aug. 19, 2019 in U.S. Appl. No. 16/208,062.
- USPTO; Non-Final Office Action dated Sep. 16, 2019 in U.S. Appl. No. 16/213,702.
- USPTO; Non-Final Office Action dated Aug. 21, 2019 in U.S. Appl. No. 29/634,768.
- WIPO; International Search Report and Written Opinion dated Jun. 28, 2019 in Application No. PCT/IB2019/000084.
- Bark et al. "Large-area niobium disulfide thin films as transparent electrodes for devices based on two-dimensional materials," *Nanoscale*, published online, 7 pages (2012).
- Barreca et al. "Cobalt oxide nanomaterials by vapor phase synthesis for fast and reversible lithium storage" *J Phys Chem C*, 114, 10054-10060 (2010).
- Basuvalingam et al. "NS-WeA6—Low Temperature ALD for Phase-controlled Synthesis of 2D Transition Metal (M=Ti, Nb) di- (MX₂) and Tri- (MX₃) Sulfides," AVS 19th International Conference on Atomic Layer Deposition (ALD 2019), Jul. 22, 2019, Abstract, 1 page (2019).
- Cahiez et al. "Cobalt-Catalyzed cross coupling reaction between functionalized primary and secondary alkyl halides and aliphatic grignard reagents" *Adv. Synth. Catal.*, 350, 1484-1488 (2008).
- "Fiji F200 200mm Thermal/Plasma ALD Systems: Installation and Use Manual." CAW-02635 Rev. 0.6 (Mar. 13, 2012). Cambridge NanoTech Inc. pp. 1-164 (2012).
- Ge et al. "Large-scale synthesis of NbS₂ nanosheets with controlled orientation on graphene by ambient pressure CVD," *Nanoscale*, vol. 5, 5773-5778 (2013).
- Gordon et al. "A Kinetic Model for Step Coverage by Atomic Layer Deposition in Narrow Holes or Trenches." *Chemical Vapor Deposition*. 9 [2]. pp. 73-78 (2003).
- Hansen. "A Primer on Vacuum Pressure Measurement." *Vacuum Technology & Coating*. Jun. 2009. pp. 36-42 (2009).
- Hansen. "Speed, Pressure and Throughput: Part 1 System Diagnostics." *Vacuum Technology & Coating*. Sep. 2011. pp. 14-17 (2011).
- Hansen. "Speed, Pressure and Throughput: Part 2 Managing Gas Flow in High Vacuum Systems." *Vacuum Technology & Coating*. Oct. 2011. pp. 19-22 (2011).
- Hansen. "Speed, Pressure and Throughput: Part 3 Automating the Pressure Control Process." *Vacuum Technology & Coating*. Nov. 2011. pp. 22-25 (2011).
- Hansen. "Speed, Pressure and Throughput: Part 4 Outgassing and Base Pressure." *Vacuum Technology & Coating*. Dec. 2011. pp. 22-25 (2011).
- Hansen. "Speed, Pressure and Throughput: Part 5 Leaks and Gas Flow in Leak Detection." *Vacuum Technology & Coating*. Jan. 2012. pp. 18-21 (2011).
- Khandelwal et al. "Low-temperature Ar/N₂ remote plasma nitridation of SiO₂ thin films," *J. Vacuum Science & Technology A*, 20(6), pp. 1989-1996 (2002).
- Kucheyev et al. "Mechanisms of Atomic Layer Deposition on Substrates with Ultrahigh Aspect Ratios." *Langmuir*. 24 [3]. pp. 943-948 (2008).
- Londergan et al. "Engineered Low Resistivity Titanium-Tantalum Nitride Films by Atomic Layer Deposition," *Mat. Res. Soc. Symp. Proc.*, vol. 714E, pp. L5.3.1-L5.3.6 (2001).
- Naito et al. "Electrical Transport Properties in 2H—NbS₂, -NbSe₂, -TaS₂ and -TaSe₂," *J. of Physical Society of Japan*, vol. 51, No. 1, 219-227 (1982).
- Pichler. "Intrinsic Point Defects, Impurities and Their Diffusion in Silicon," Springer-Verlag Wien, p. 367 (2004).
- Tidman et al. "Resistivity of thin TaS₂ crystals," *Can. J. Phys.*, vol. 54, 2306-2309 (1976).
- Trumbore et al. "Solid solubilities of aluminum and gallium in germanium," *J. of Physics and Chemistry of Solids*, vol. 11, Issues 3-4, 239-240 (1959).
- CNIPA; Office Action dated Dec. 14, 2018 in Application No. 201410331047.6.
- CNIPA; Notice of Allowance dated Jun. 14, 2019 in Application No. 201410331047.6.
- CNIPA; Office Action dated Jun. 28, 2019 in Application No. 201510765170.3.
- CNIPA; Office Action dated Oct. 19, 2018 in Application No. 201510765170.3.
- CNIPA; Office Action dated Oct. 31, 2018 in Application No. 201510765406.3.
- CNIPA; Office Action dated Jun. 28, 2019 in Application No. 201510765406.3.
- CNIPA; Office Action dated Mar. 14, 2019 in Application No. 201610141027.1.
- CNIPA; Office Action dated Dec. 20, 2018 in Application No. 201710738549.4.
- CNIPA; Office Action dated Jun. 20, 2019 in Application No. 201711120632.1.
- CNIPA; Notice of Allowance dated Nov. 1, 2018 in Application No. 201830397219.9.
- EPO; Office Action dated Jan. 11, 2019 in Application No. 09836647.9.
- JPO; Office Action dated Aug. 10, 2009 in Application No. 2003029767.
- JPO; Office Action dated Apr. 13, 2010 in Application No. 2003029767.
- JPO; Notice of Allowance dated Jun. 24, 2010 in Application No. 2003029767.
- JPO; Office Action dated Oct. 30, 2008 in Application No. 2004558313.
- JPO; Office Action dated Feb. 19, 2009 in Application No. 2004558313.

(56)

References Cited

OTHER PUBLICATIONS

- JPO; Notice of Allowance dated Jun. 30, 2009 in Application No. 2004558313.
- JPO; Notice of Allowance dated Dec. 19, 2018 in Application No. 2014205548.
- JPO; Office Action dated Jun. 27, 2019 in Application No. 2015034774.
- JPO; Office Action dated Jan. 30, 2019 in Application No. 2015052198.
- JPO; Notice of Allowance dated Apr. 5, 2019 in Application No. 2015052198.
- KIPO; Office Action dated Jan. 12, 2019 in Application No. 10-2012-0064526.
- KIPO; Office Action dated Mar. 27, 2019 in Application No. 10-2012-0076564.
- KIPO; Office Action dated May 30, 2019 in Application No. 10-2012-7004062.
- KIPO; Decision of Intellectual Property Trial and Appeal Board dated May 13, 2019 in Application No. 10-2012-7004062.
- KIPO; Office Action dated Apr. 19, 2019 in Application No. 10-2013-0101944.
- KIPO; Office Action dated Apr. 24, 2019 in Application No. 10-2013-0036823.
- KIPO; Office Action dated May 31, 2019 in Application No. 10-2013-0050740.
- KIPO; Office Action dated Mar. 27, 2019 in Application No. 10-2013-0084459.
- KIPO; Office Action dated Apr. 30, 2019 in Application No. 10-2013-0088450.
- KIPO; Office Action dated May 21, 2019 in Application No. 10-2013-0121554.
- KIPO; Office Action dated Jan. 22, 2019 in Application No. 10-2014-7017110.
- KIPO; Notice of Allowance dated Feb. 27, 2018 in Application No. 10-2017-0175442.
- KIPO; Office Action dated Jan. 30, 2019 in Application No. 30-2018-0033442.
- KIPO; Notice of Allowance dated Apr. 1, 2019 in Application No. 30-2018-0033442.
- TIPO; Notice of Allowance dated Jan. 28, 2015 in Application No. 99114329.
- TIPO; Office Action dated Jun. 20, 2017 in Application No. 102125191.
- TIPO; Notice of Allowance dated Jan. 30, 2019 in Application No. 103132230.
- TIPO; Office Action dated Feb. 22, 2019 in Application No. 104105533.
- TIPO; Office Action dated Nov. 19, 2018 in Application No. 104105965.
- TIPO; Notice of Allowance dated May 9, 2019 in Application No. 104107876.
- TIPO; Notice of Allowance dated Apr. 26, 2019 in Application No. 104107888.
- TIPO; Office Action dated May 6, 2019 in Application No. 104108277.
- TIPO; Notice of Allowance dated May 8, 2019 in Application No. 104110326.
- TIPO; Office Action dated Apr. 29, 2019 in Application No. 104122889.
- TIPO; Office Action dated Jan. 30, 2019 in Application No. 104122890.
- TIPO; Notice of Allowance dated Jun. 19, 2019 in Application No. 104124377.
- TIPO; Office Action dated Jan. 7, 2019 in Application No. 104132991.
- TIPO; Notice of Allowance dated Apr. 12, 2019 in Application No. 104132991.
- TIPO; Office Action dated Apr. 25, 2019 in Application No. 104141679.
- TIPO; Office Action dated Apr. 25, 2019 in Application No. 105101536.
- TIPO; Notice of Allowance dated May 7, 2019 in Application No. 105104453.
- TIPO; Office Action dated Dec. 26, 2018 in Application No. 106127690.
- TIPO; Office Action dated Jan. 7, 2019 in Application No. 106138800.
- TIPO; Office Action dated Nov. 20, 2018 in Application No. 107118271.
- TIPO; Office Action dated Jun. 4, 2019 in Application No. 107123992.
- TIPO; Office Action dated May 28, 2019 in Application No. 107125586.
- TIPO; Notice of Allowance dated Feb. 21, 2019 in Application No. 107303723.
- TIPO; Office Action dated May 31, 2019 in Application No. 108102146.
- USPTO; Notice of Allowance dated Apr. 4, 2019 in U.S. Appl. No. 12/618,355.
- USPTO; Advisory Action dated Feb. 4, 2019 in U.S. Appl. No. 13/169,951.
- USPTO; Notice of Allowance dated Apr. 4, 2019 in U.S. Appl. No. 13/169,951.
- USPTO; Final Office Action dated Dec. 28, 2018 in U.S. Appl. No. 13/184,351.
- USPTO; Final Office Action dated Mar. 15, 2019 in U.S. Appl. No. 13/651,144.
- USPTO; Final Office Action dated Jan. 25, 2019 in U.S. Appl. No. 14/188,760.
- USPTO; Non-Final Office Action dated Jul. 15, 2019 in U.S. Appl. No. 14/219,839.
- USPTO; Advisory Action dated Jan. 22, 2019 in U.S. Appl. No. 14/219,879.
- USPTO; Non-Final Office Action dated Jun. 24, 2019 in U.S. Appl. No. 14/219,879.
- USPTO; Final Office Action dated Feb. 7, 2019 in U.S. Appl. No. 14/444,744.
- USPTO; Non-Final Office Action dated Jan. 11, 2019 in U.S. Appl. No. 14/457,058.
- USPTO; Final Office Action dated Jun. 25, 2019 in U.S. Appl. No. 14/457,058.
- USPTO; Non-Final Office Action dated Apr. 4, 2019 in U.S. Appl. No. 14/508,489.
- USPTO; Non-Final Office Action dated Dec. 28, 2018 in U.S. Appl. No. 14/752,712.
- USPTO; Notice of Allowance dated Jun. 11, 2019 in U.S. Appl. No. 14/752,712.
- USPTO; Final Office Action dated Feb. 25, 2019 in U.S. Appl. No. 14/793,323.
- USPTO; Non-Final Office Action dated Jun. 27, 2019 in U.S. Appl. No. 14/793,323.
- USPTO; Final Office Action dated Apr. 18, 2019 in U.S. Appl. No. 14/829,565.
- USPTO; Advisory Action dated Jul. 22, 2019 in U.S. Appl. No. 14/829,565.
- USPTO; Notice of Allowance dated Mar. 25, 2019 in U.S. Appl. No. 14/997,683.
- USPTO; Non-Final Office Action dated Jun. 3, 2019 in U.S. Appl. No. 15/060,412.
- USPTO; Notice of Allowance dated Dec. 21, 2018 in U.S. Appl. No. 15/067,028.
- USPTO; Notice of Allowance dated Feb. 25, 2019 in U.S. Appl. No. 15/074,813.
- USPTO; Final Office Action dated Mar. 14, 2019 in U.S. Appl. No. 15/135,258.
- USPTO; Non-Final Office Action dated Jul. 19, 2019 in U.S. Appl. No. 15/135,258.
- USPTO; Notice of Allowance dated Mar. 13, 2019 in U.S. Appl. No. 15/144,506.
- USPTO; Final Office Action dated Mar. 28, 2019 in U.S. Appl. No. 15/182,504.
- USPTO; Notice of Allowance dated Jul. 17, 2019 in U.S. Appl. No. 15/182,504.
- USPTO; Non-Final Office Action dated Mar. 28, 2019 in U.S. Appl. No. 15/205,827.
- USPTO; Notice of Allowance dated Apr. 19, 2019 in U.S. Appl. No. 15/222,780.
- USPTO; Non-Final Office Action dated Jan. 30, 2019 in U.S. Appl. No. 15/262,990.
- USPTO; Final Office Action dated May 13, 2019 in U.S. Appl. No. 15/262,990.

(56)

References Cited

OTHER PUBLICATIONS

- USPTO; Advisory Action dated Jul. 22, 2019 in U.S. Appl. No. 15/262,990.
- USPTO; Final Office Action dated Jan. 11, 2019 in U.S. Appl. No. 15/273,488.
- USPTO; Notice of Allowance dated Apr. 19, 2019 in U.S. Appl. No. 15/273,488.
- USPTO; Final Office Action dated Feb. 7, 2019 in U.S. Appl. No. 15/286,503.
- USPTO; Non-Final Office Action dated Jun. 27, 2019 in U.S. Appl. No. 15/286,503.
- USPTO; Non-Final Office Action dated Dec. 14, 2018 in U.S. Appl. No. 15/340,512.
- USPTO; Notice of Allowance dated May 24, 2019 in U.S. Appl. No. 15/340,512.
- USPTO; Final Office Action dated Jun. 25, 2019 in U.S. Appl. No. 15/377,439.
- USPTO; Non-Final Office Action dated May 31, 2019 in U.S. Appl. No. 15/380,909.
- USPTO; Non-Final Office Action dated Feb. 25, 2019 in U.S. Appl. No. 15/380,921.
- USPTO; Non-Final Office Action dated Feb. 5, 2019 in U.S. Appl. No. 15/402,993.
- USPTO; Final Office Action dated May 21, 2019 in U.S. Appl. No. 15/402,993.
- USPTO; Final Office Action dated Feb. 4, 2019 in U.S. Appl. No. 15/410,503.
- USPTO; Non-Final Office Action dated Apr. 25, 2019 in U.S. Appl. No. 15/410,503.
- USPTO; Final Office Action dated Jan. 11, 2019 in U.S. Appl. No. 15/428,808.
- USPTO; Notice of Allowance dated Apr. 25, 2019 in U.S. Appl. No. 15/428,808.
- USPTO; Non-Final Office Action dated Jan. 25, 2019 in U.S. Appl. No. 15/434,051.
- USPTO; Notice of Allowance dated Jun. 3, 2019 in U.S. Appl. No. 15/434,051.
- USPTO; Final Office Action dated Feb. 27, 2019 in U.S. Appl. No. 15/489,453.
- USPTO; Non-Final Office Action dated Jun. 5, 2019 in U.S. Appl. No. 15/489,453.
- USPTO; Final Office Action dated May 1, 2019 in U.S. Appl. No. 15/491,726.
- USPTO; Final Office Action dated Mar. 6, 2019 in U.S. Appl. No. 15/589,849.
- USPTO; Non-Final Office Action dated Jun. 28, 2019 in U.S. Appl. No. 15/589,849.
- USPTO; Non-Final Office Action dated Dec. 21, 2018 in U.S. Appl. No. 15/589,861.
- USPTO; Final Office Action dated Jun. 26, 2019 in U.S. Appl. No. 15/589,861.
- USPTO; Advisory Action dated Mar. 15, 2019 in U.S. Appl. No. 15/592,730.
- USPTO; Non-Final Office Action dated Mar. 7, 2019 in U.S. Appl. No. 15/598,169.
- USPTO; Final Office Action dated Jun. 25, 2019 in U.S. Appl. No. 15/598,169.
- USPTO; Ex Parte Quayle Action dated Mar. 21, 2019 in U.S. Appl. No. 15/615,489.
- USPTO; Non-Final Office Action dated Feb. 1, 2019 in U.S. Appl. No. 15/627,189.
- USPTO; Notice of Allowance dated May 21, 2019 in U.S. Appl. No. 15/627,189.
- USPTO; Final Office Action dated Mar. 6, 2019 in U.S. Appl. No. 15/636,307.
- USPTO; Non-Final Office Action dated Jul. 16, 2019 in U.S. Appl. No. 15/636,307.
- USPTO; Notice of Allowance dated Jun. 24, 2019 in U.S. Appl. No. 15/650,686.
- USPTO; Notice of Allowance dated Feb. 21, 2019 in U.S. Appl. No. 15/659,631.
- USPTO; Non-Final Office Action dated Mar. 1, 2019 in U.S. Appl. No. 15/660,805.
- USPTO; Notice of Allowance dated Feb. 21, 2019 in U.S. Appl. No. 15/662,107.
- UPSTO; Notice of Allowance dated Mar. 20, 2019 in U.S. Appl. No. 15/672,063.
- USPTO; Non-Final Office Action dated Feb. 8, 2019 in U.S. Appl. No. 15/672,119.
- USPTO; Final Office Action dated Jul. 16, 2019 in U.S. Appl. No. 15/672,119.
- USPTO; Notice of Allowance dated Jan. 9, 2019 in U.S. Appl. No. 15/673,110.
- USPTO; Notice of Allowance dated May 6, 2019 in U.S. Appl. No. 15/673,278.
- USPTO; Notice of Allowance dated Jan. 9, 2019 in U.S. Appl. No. 15/683,701.
- USPTO; Non-Final Office Action dated Mar. 19, 2019 in U.S. Appl. No. 15/691,241.
- USPTO; Final Office Action dated Jan. 11, 2019 in U.S. Appl. No. 15/691,241.
- USPTO; Notice of Allowance dated Apr. 16, 2019 in U.S. Appl. No. 15/705,955.
- USPTO; Non-Final Office Action dated Feb. 11, 2019 in U.S. Appl. No. 15/707,786.
- USPTO; Non-Final Office Action dated Jun. 25, 2019 in U.S. Appl. No. 15/719,208.
- USPTO; Notice of Allowance dated Apr. 19, 2019 in U.S. Appl. No. 15/726,222.
- USPTO; Notice of Allowance dated Jan. 23, 2019 in U.S. Appl. No. 15/729,485.
- USPTO; Final Office Action dated Apr. 19, 2019 in U.S. Appl. No. 15/795,056.
- USPTO; Non-Final Office Action dated Jun. 14, 2019 in U.S. Appl. No. 15/796,593.
- USPTO; Final Office Action dated Feb. 21, 2019 in U.S. Appl. No. 15/796,593.
- USPTO; Non-Final Office Action dated Dec. 21, 2018 in U.S. Appl. No. 15/798,150.
- USPTO; Notice of Allowance dated May 14, 2019 in U.S. Appl. No. 15/798,150.
- USPTO; Final Office Action dated Dec. 14, 2018 in U.S. Appl. No. 15/798,201.
- USPTO; Final Office Action dated Mar. 7, 2019 in U.S. Appl. No. 15/815,483.
- USPTO; Notice of Allowance dated Dec. 5, 2017 in U.S. Appl. No. 15/832,188.
- USPTO; Non-Final Office Action dated Mar. 13, 2019 in U.S. Appl. No. 15/836,547.
- USPTO; Non-Final Office Action dated Jan. 11, 2019 in U.S. Appl. No. 15/879,209.
- USPTO; Non-Final Office Action dated Jan. 22, 2019 in U.S. Appl. No. 15/879,209.
- USPTO; Non-Final Office Action dated Apr. 17, 2019 in U.S. Appl. No. 15/886,225.
- USPTO; Final Office Action dated May 2, 2019 in U.S. Appl. No. 15/890,037.
- USPTO; Notice of Allowance dated Feb. 8, 2019 in U.S. Appl. No. 15/892,756.
- USPTO; Non-Final Office Action dated Apr. 24, 2019 in U.S. Appl. No. 15/896,986.
- USPTO; Non-Final Office Action dated May 30, 2019 in U.S. Appl. No. 15/900,425.
- USPTO; Non-Final Office Action dated Mar. 8, 2019 in U.S. Appl. No. 15/917,224.
- USPTO; Non-Final Office Action dated Feb. 8, 2019 in U.S. Appl. No. 15/917,262.
- USPTO; Final Office Action dated Jun. 14, 2019 in U.S. Appl. No. 15/917,262.
- USPTO; Non-Final Office Action dated May 8, 2019 in U.S. Appl. No. 15/925,532.

(56)

References Cited

OTHER PUBLICATIONS

- USPTO; Non-Final Office Action dated Mar. 29, 2019 in U.S. Appl. No. 15/940,801.
- USPTO; Notice of Allowance dated May 31, 2019 in U.S. Appl. No. 15/957,565.
- USPTO; Non-Final Office Action dated Apr. 19, 2019 in U.S. Appl. No. 15/985,298.
- USPTO; Non-Final Office Action dated Feb. 21, 2019 in U.S. Appl. No. 15/987,755.
- USPTO; Non-Final Office Action dated Jul. 16, 2019 in U.S. Appl. No. 16/014,981.
- USPTO; Non-Final Office Action dated Jan. 24, 2019 in U.S. Appl. No. 16/018,692.
- USPTO; Notice of Allowance dated Apr. 9, 2019 in U.S. Appl. No. 16/026,711.
- USPTO; Non-Final Office Action dated Apr. 25, 2019 in U.S. Appl. No. 16/038,024.
- USPTO; Non-Final Office Action dated Apr. 2, 2019 in U.S. Appl. No. 16/147,047.
- USPTO; Notice of Allowance dated Apr. 17, 2019 in U.S. Appl. No. 16/171,098.
- USPTO; Notice of Allowance dated May 1, 2019 in U.S. Appl. No. 16/171,098.
- USPTO; Non-Final Office Action dated Apr. 2, 2019 in U.S. Appl. No. 16/188,690.
- USPTO; Notice of Allowance dated Jun. 13, 2019 in U.S. Appl. No. 16/396,475.
- USPTO; Non-Final Office Action dated Apr. 16, 2019 in U.S. Appl. No. 29/604,101.
- USPTO; Non-Final Office Action dated Feb. 20, 2019 in U.S. Appl. No. 29/646,377.
- WIPO; International Search Report and Written Opinion dated Jan. 25, 2019 in Application No. PCT/IB2018/000192.
- WIPO; International Search Report and Written Opinion dated Jan. 4, 2019 in Application No. PCT/IB2018/000936.
- WIPO; International Search Report and Written Opinion dated Dec. 20, 2018 in Application No. PCT/IB2018/001003.
- WIPO; International Search Report and Written Opinion dated Dec. 20, 2018 in Application No. PCT/IB2018/001022.
- WIPO; International Search Report and Written Opinion dated May 23, 2019 in Application No. PCT/IB2019/050974.
- Alen, "Atomic layer deposition of TaN, NbN and MoN films for Cu Metallizations," University of Helsinki Finland, 72 pages, (2005).
- Arita et al. "Electrical and optical properties of germanium-doped zinc oxide thin films" *Materials Transactions*, vol. 45, No. 11, pp. 3180-3183 (2004).
- Arnold et al., "Novel single-layer vanadium sulphide phases" *2D Materials*, 5, 045009, 11 pages (2018).
- Boscher et al., "Atmosphere Pressure Chemical Vapour Deposition of NbSe₂ Thin Films on Glass" *Eur. J. Inorg. Chem.*, pp. 1255-1259 (2006).
- Carmalt et al., "Chemical Vapor Deposition of Niobium Disulfide Thin Films" *Eur. J. Inorg. Chem.*, pp. 4470-4476 (2004).
- Casey et al. "Chemical Vapor Deposition of Mo onto Si" *J. Electrochem. Soc.: Solid State Science*, 114 (2), pp. 201-204 (1967).
- Chen et al., "Develop Gap-fill Process of Shallow Trench Isolation in 450mm Wafer by Advanced Flowable CVD Technology for Sub-20nm Node," 2016 27th Annual Semi Advanced Semiconductor Manufacturing Conference (ASMC), IEEE, May 16, 2016, pp. 157-159 (2016).
- Cheng et al., "Effect of carrier gas on the structure and electric properties of low dielectric constant SiCOH film using trimethylsilane prepared by plasma enhanced chemical vapor deposition," *Thin Solid Films* vol. 469-470, pp. 178-183 (2004).
- Closser et al., "Molecular Layer Deposition of a Highly Stable Silicon Oxycathide Thin Film Using an Organic Chlorosilane and Water," *ACS Applied Materials & Interfaces* 10, pp. 24266-24274 (2018).
- Conroy et al., "The Preparation and Properties of Single Crystals of the 1S and 2S Polymorphs of Tantalum Disulfide" *J. Solid State Chemistry*, 4, pp. 345-350 (1972).
- De Silva et al., "Inorganic Hardmask Development for Extreme Ultraviolet Patterning," *Journal of Micro/Nanolithography, MEMS, and MOEMS* 18(1) (2018).
- Duffey et al., "Raman Scattering from 1T-TaS₂" *Solid State Communications* 20, pp. 617-621.
- Elers et al. "Film Uniformity in Atomic Layer Deposition," *Chemical Vapor Deposition*, 12, pp. 13-24 (2006).
- Fu et al., "Controlled Synthesis of Atomically Thin 1T-TaS₂ for Tunable Charge Density Wave Phase Transitions" *Chem. Mater.* 28, pp. 7613-7618 (2016).
- Gesheva et al. "Composition and Microstructure of Black Molybdenum Photothermal Converter Layers Deposited by the Pyrolytic Hydrogen Reduction of MoO₂Cl₂" *Thin Solid Films*, 79, pp. 39-49 (1981).
- Gole et al. "Preparation of Nickel Sulfide Thin Films and Nanocrystallites Using Nickel Furfuraldehyde Thiosemicarbazone as Single-source Precursor," *Advanced Materials Research*, vols. 383-390, pp. 3828-3834 (2012).
- Habib et al. "Atmospheric oxygen plasma activation of silicon (100) surfaces," *American Vacuum Society*, 28(3), pp. 476-485 (2010).
- Han et al., "van der Waals Metallic Transition Metal Dichalcogenides" *Chem. Rev.* 118, pp. 6297-6336 (2018).
- Heyne et al., "The conversion mechanism of amorphous silicon to stoichiometric WS₂" *J. Materials Chemistry C*, 6, pp. 4122-4130 (2018).
- Hossain et al., "Recent Advances in Two-Dimensional Materials with Charge Density Waves: Synthesis, Characterization and Applications" *Crystals* 7, 298, 19 pp. (2017).
- Johansson et al. "Towards absolute asymmetric synthesis. Synthesis and crystal structure of stereochemically labile MC₁₂ (M=CO, Ni, Cu, Zn) complexes with diamine ligands," *Inorganica Chimica Acta* 358, pp. 3293-3302 (2005).
- Jung et al. "New Mechanisms for Ozone-Based ALO Growth of High-k Dielectrics via Nitrogen-Oxygen Species" *ECS Transactions*, 33(2), pp. 91-99 (2010).
- Kern et al., "Chemically Vapor-Deposited Borophosphosilicate Glasses for Silicon Device Applications" *RCE Review*, 43, 3, pp. 423-457 (1982).
- Kerrigan et al. "Low Temperature, Selective Atomic Layer Deposition of Cobalt Metal Films Using Bis(1,4-di-tert-butyl-1,3-diazadienyl)cobalt and Alkylamine Precursors," *Chem. Materials*, 29, pp. 7458-7466 (2017).
- Kim et al., "Novel Flowable CVD Process Technology for sub-20nm Interlayer Dielectrics," *IEEE International Interconnect Technology Conference (IITC 2012)*, San Jose, California, USA, Jun. 4-6, 2012, pp. 1-3 (2012).
- Kogelschatz et al. "Ozone Generation from Oxygen and Air: Discharge Physics and Reaction Mechanisms" *Ozone Science & Engineering*, 10, pp. 367-378 (1998).
- Kukli et al., "Influence of atomic layer deposition parameters on the phase content of Ta₂O₅ films" *J. Crystal Growth*, 212, pp. 459-468 (2000).
- Kukli et al. "Properties of tantalum oxide thin films grown by atomic layer deposition" *Thin Solid Films*, 260, pp. 135-142 (1995).
- Kwon et al., "Substrate Selectivity of (tBu-Allyl)Co(CO)₃ during Thermal Atomic Layer Deposition of Cobalt," *Chem. Materials*, 24, pp. 1025-1030 (2012).
- Lee et al., "Characteristics of Low- K Sioc Films Deposited Via Atomic Layer Deposition," *Thin Solid Films* 645, pp. 334-339 (2018).
- Levy et al., "Reflow Mechanisms of Contact Vias in VLSI Processing" *J. Electrochem. Soc.: Solid-State Science and Technology*, 133, 7, pp. 1417-1424 (1986).
- Li et al., "Metallic Transition-Metal Dichalcogenide Nanocatalysts for Energy Conversion" *Chem.* 4, pp. 1510-1537 (2018).
- Lieberman, et al., "Principles of Plasma Discharges and Materials Processing" Second Edition, 368-381 (2005).
- Lim et al. "Synthesis and Characterization of Volatile, Thermally Stable, Reactive Transition Metal Amidinates," *Inorg. Chem.*, 42, pp. 7951-7958 (2003).

(56)

References Cited

OTHER PUBLICATIONS

- Liu et al., "Van der Waals metal-semiconductor junction: Weak Fermi level pinning enables effective tuning of Schottky barrier" *Sci. Adv.* 2: e1600069, 7 pages (2016).
- Maeno, "Gecko Tape Using Carbon Nanotubes," *Nitto Denko Gihou*, 47, 48-51 (2009).
- Makela et al. "Thermal Atomic Layer Deposition of Continuous and Highly Conducting Gold Thin Films," *Chem. Materials*, 29, pp. 6130-6136 (2017).
- Mattinen et al., "Crystalline tungsten sulfide thin films by atomic layer deposition and mild annealing" *J. Vac. Sci. Tech.* 37, 020921, 35 pages (2019).
- Nakano et al., "Layer-by-Layer Epitaxial Growth of Scalable WSe₂ on Sapphire by Molecular Beam Epitaxy" *Nano. Lett.* 17, pp. 5595-5599 (2017).
- Ngo et al. "Atomic layer deposition of photoactive CoO/SrTiO₃ and CoO/TiO₂ on Si(001) for visible light driven photoelectrochemical water oxidation," *J. Applied Physics*, 114, 9 pages (2013).
- Ohchi et al. "Reducing damage to Si substrates during gate etching processes." *Japanese Journal of Applied Physics* 47.7R 5324 (2008).
- Peters et al., "Aerosol-Assisted Chemical Vapor Deposition of NbS₂ and TaS₂ Thin Films from Pentakis(dimethylamido)metal Complexes and 2-Methylpropanethiol" *Eur. J. Inorg. Chem.*, pp. 4179-4185 (2005).
- Radamson et al. "Growth of Sn-alloyed Group IV Materials for Photonic and Electronic Applications" Chapter 5 pp. 129-144, *Manufacturing Nano Structures* (2014).
- Ryu et al., "Persistent Charge-Density-Wave Order in Single-Layer TaSe₂" *Nano. Lett.* 18, pp. 689-694 (2018).
- Samal et al., "Low-Temperature (<200° C.) Plasma Enhanced Atomic Deposition of Dense Titanium Nitride Thin Films" (2012).
- Sanders et al., "Crystalline and electronic structure of single-layer TaS₂" *Phys. Rev. B.* 94, 081404, 6 pages (2016).
- Schindler, Dissertation, Next Generation High-k Dielectrics for DRAM Produced by Atomic Layer Deposition Studied by Transmission Electron Microscopy (2015).
- Sellers, Making Your Own Timber Dogs, Paul Sellers blog, Published on Nov. 18, 2014, [online], [site visited Jun. 10, 2017]. Available from Internet, <URL: <https://paulsellers.com/2014/11/making-your-own-timber-dogs/>>.
- Seshadri et al., "Ultrathin Extreme Ultraviolet Patterning Stack Using Polymer Brush as an Adhesion Promotion Layer," *Journal of Micro/Nanolithography, MEMS, and MOEMS* 16(3) (2017).
- Simchi et al., "Sulfidation of 2D transition metals (Mo, W, Re, Nb, Ta): thermodynamics, processing, and characterization" *J. Materials Science* 52: 17, 9 pages (2017).
- Stanley et al. "Feedgas for Modern High-Performance Ozone Generators" Ozonia Ltd., Duebendorf, Switzerland. 7 pages. Available Jul. 14, 2017 online at: http://www.degremont-technologies.com/cms_medias/pdf/tech_ozonia_feedgas.pdf (1999).
- Svetin et al., "Three-dimensional resistivity and switching between correlated electronic states in 1T-TaS₂" *Nature, Scientific Reports* Apr. 12, 2017, 7:46048, 10 pages (2017).
- Tatehaba et al., "Adhesion Energy of Polystyrene and Substrate in Function Water," 5th International Symposium of Cleaning Technology in Semiconductor Device Manufacturing, pp. 560-565 (1998).
- Todi et al., "Characterization of Pt—Ru Binary Alloy Thin Films for Work Function Tuning," *IEEE Electron Device Letters*, vol. 27, No. 7, pp. 542-545 (2006).
- Ueda et al. "Enhanced Sidewall Grown (ESG) process: towards PEALD with conformality above 100%," *Extended Abstracts of the 2011 International Conference on Solid State Devices and Materials*, Nagoya, pp. 34-35 (2011).
- Vasilev, "Borophosphosilicate Glass Films in Silicon Microelectronics, Part 1: Chemical Vapor Deposition, Composition, and Properties" *Russian Microelectronics*, vol. 33, No. 5, pp. 271-284 (2004).
- Xing et al., "Ising Superconductivity and Quantum Phase Transition in Macro-Size Monolayer NbSe₂" *Nano. Lett.* 17, pp. 6802-6807 (2017).
- Xu et al., "Contacts between Two- and Three- Dimensional Materials: Ohmic, Schottky, and p-n. Heterojunctions" *ACS Nano* 10, pp. 4895-4919 (2016).
- Yuan et al., "Facile Synthesis of Single Crystal Vanadium Disulfide Nanosheets by Chemical Vapor Deposition for Efficient Hydrogen Evolution Reaction" *Adv. Mater.* 27, pp. 5605-5609 (2015).
- Zhou et al., "A library of atomically thin metal chalcogenides" *Nature* 556, pp. 355-361 (2018).
- EPO; Notice of Allowance dated Oct. 16, 2019 in Application No. 09836647.9.
- KIPO; Notice of Allowance dated Sep. 27, 2019 in Application No. 10-2012-7004062.
- KIPO; Office Action dated Nov. 27, 2019 in Application No. 10-2013-0050740.
- KIPO; Office Action dated Nov. 12, 2019 in Application No. 10-2013-0102026.
- KIPO; Notice of Allowance dated Oct. 21, 2019 in Application No. 10-2013-0109390.
- KIPO; Notice of Allowance dated Oct. 28, 2019 in Application No. 10-2013-0121554.
- KIPO; Notice of Allowance dated Nov. 29, 2019 in Application No. 10-2019-0127773.
- TIPO; Office Action dated Nov. 6, 2019 in Application No. 105101537.
- TIPO; Office Action dated Oct. 1, 2019 in Application No. 105114105.
- TIPO; Office Action dated Oct. 3, 2019 in Application No. 105119533.
- TIPO; Office Action dated Oct. 28, 2019 in Application No. 105122715.
- USPTO; Non-Final Office Action dated Oct. 31, 2019 in U.S. Appl. No. 14/457,058.
- USPTO; Advisory Action dated Oct. 28, 2019 in U.S. Appl. No. 14/508,489.
- USPTO; Notice of Allowance dated Nov. 14, 2019 in U.S. Appl. No. 14/793,323.
- USPTO; Final Office Action dated Oct. 24, 2019 in U.S. Appl. No. 15/135,258.
- USPTO; Advisory Action dated Oct. 22, 2019 in U.S. Appl. No. 15/205,827.
- USPTO; Non-Final Office Action dated Nov. 7, 2019 in U.S. Appl. No. 15/377,439.
- USPTO; Final Office Action dated Sep. 18, 2019 in U.S. Appl. No. 15/380,921.
- USPTO; Non-Final Office Action dated Oct. 24, 2019 in U.S. Appl. No. 15/402,993.
- USPTO; Notice of Allowance dated Oct. 7, 2019 in U.S. Appl. No. 15/489,453.
- USPTO; Non-Final Office Action dated Oct. 3, 2019 in U.S. Appl. No. 15/491,726.
- USPTO; Advisory Action dated Sep. 20, 2019 in U.S. Appl. No. 15/589,861.
- USPTO; Final Office Action dated Nov. 12, 2019 in U.S. Appl. No. 15/636,307.
- USPTO; Notice of Allowance dated Nov. 7, 2019 in U.S. Appl. No. 15/660,797.
- USPTO; Non-Final Office Action dated Oct. 10, 2019 in U.S. Appl. No. 15/672,096.
- USPTO; Advisory Action dated Sep. 23, 2019 in U.S. Appl. No. 15/672,119.
- USPTO; Non-Final Office Action dated Nov. 20, 2019 in U.S. Appl. No. 15/690,017.
- USPTO; Notice of Allowance dated Nov. 7, 2019 in U.S. Appl. No. 15/707,786.
- USPTO; Non-Final Office Action dated Sep. 26, 2019 in U.S. Appl. No. 15/727,432.
- USPTO; Non-Final Office Action dated Nov. 20, 2019 in U.S. Appl. No. 15/795,056.
- USPTO; Non-Final Office Action dated Nov. 15, 2019 in U.S. Appl. No. 15/802,154.
- USPTO; Final Office Action dated Nov. 13, 2019 in U.S. Appl. No. 15/860,564.
- USPTO; Advisory Action dated Nov. 5, 2019 in U.S. Appl. No. 15/879,209.
- USPTO; Non-Final Office Action dated Oct. 24, 2019 in U.S. Appl. No. 15/890,037.

(56)

References Cited

OTHER PUBLICATIONS

USPTO; Final Office Action dated Nov. 19, 2019 in U.S. Appl. No. 15/896,986.

USPTO; Non-Final Office Action dated Jul. 25, 2019 in U.S. Appl. No. 16/039,867.

USPTO; Notice of Allowance dated Oct. 3, 2019 in U.S. Appl. No. 16/200,100.

USPTO; Non-Final Office Action dated Sep. 24, 2019 in U.S. Appl. No. 16/251,534.

USPTO; Notice of Allowance dated Oct. 30, 2019 in U.S. Appl. No. 29/604,101.

USPTO; Final Office Action dated Jul. 15, 2019 in U.S. Appl. No. 29/646,377.

USPTO; Notice of Allowance dated Nov. 14, 2019 in U.S. Appl. No. 29/646,377.

Ellis et al. "Nitrous Oxide (N₂O) Processing for Silicon Oxynitride Gate Dielectrics." IBM Journal of Research and Development. 1999. 43[3]. pp. 287-300. (1999).

Hayashi et al. "Spectroscopic properties of nitrogen doped hydrogenated amorphous carbon films grown by radio frequency plasma-enhanced chemical vapor deposition," Journal of Applied Physics. vol. 89, No. 12, pp. 7924-7931 (2001).

Miller et al. "Carbon nitrides: synthesis and characterization of a new class of functional materials," Phys.Chem.Chem.Phys., 19, pp. 15613-15638 (2017).

Ohtsu et al. "Influences of Gap Distance on Plasma Characteristics in Narrow Gap Capacitatively Coupled Radio-Frequency Discharge," vol. 43, No. 2, pp. 795-799 (2004).

* cited by examiner

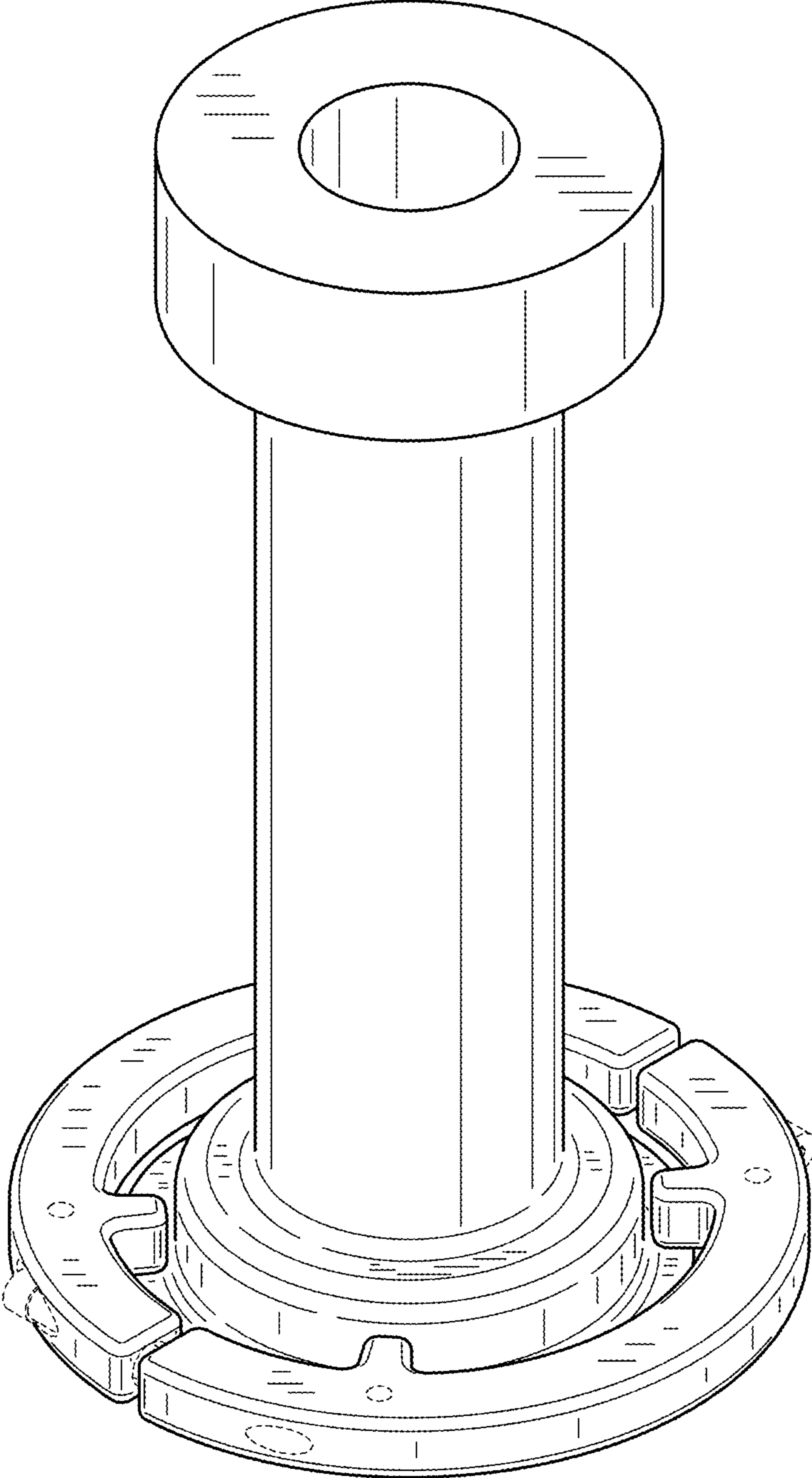

FIG. 1

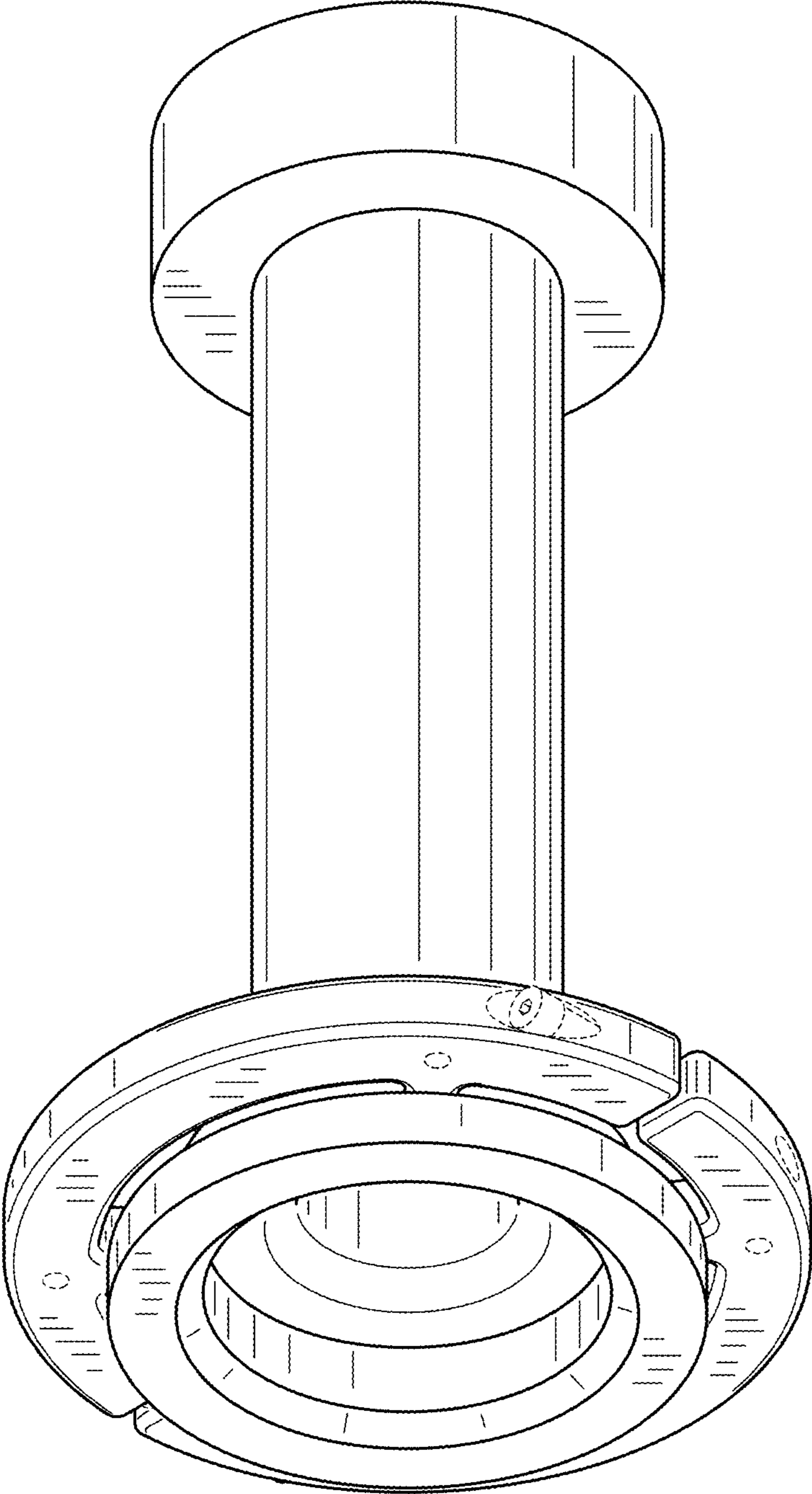

FIG.2

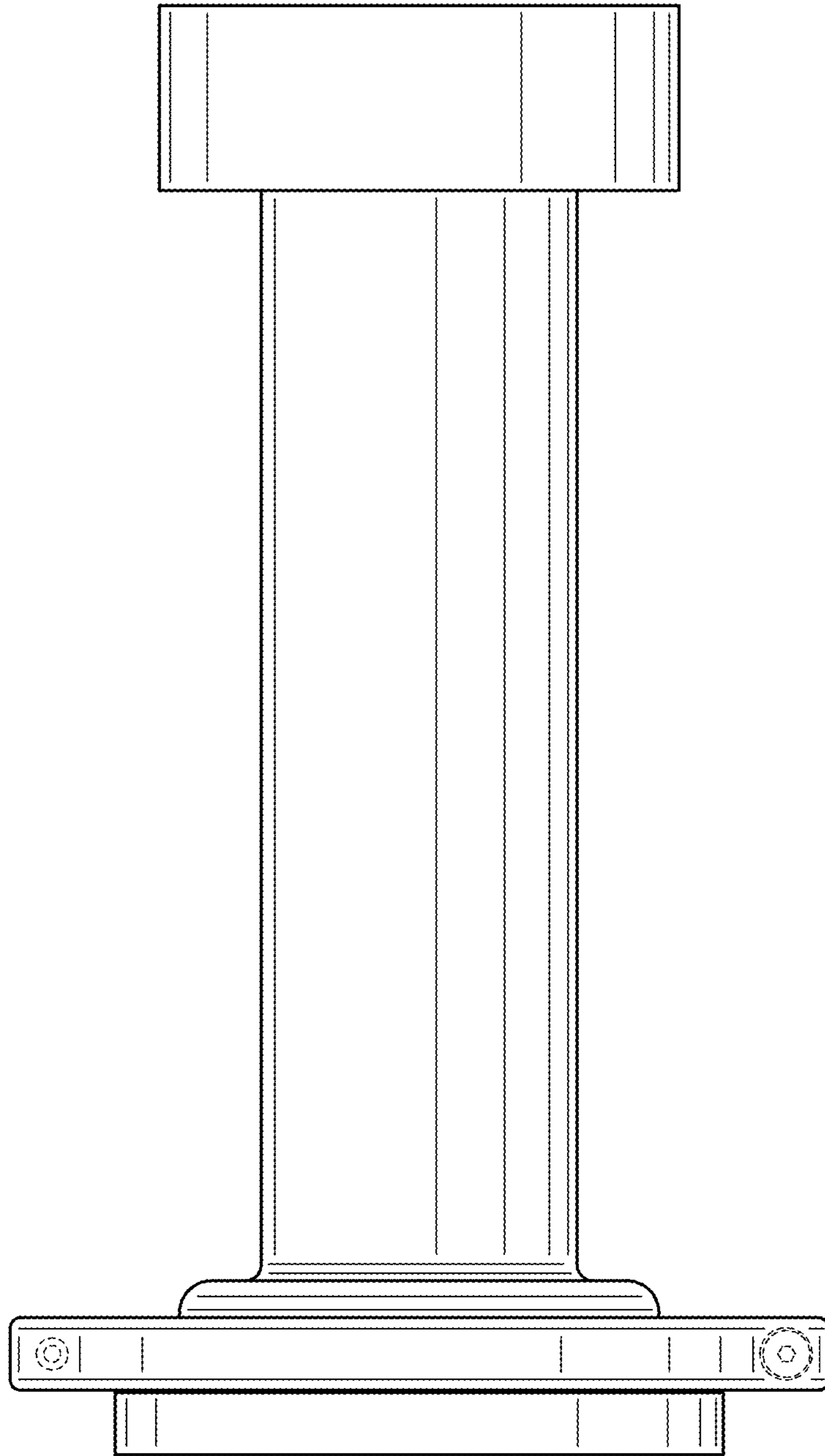

FIG. 3

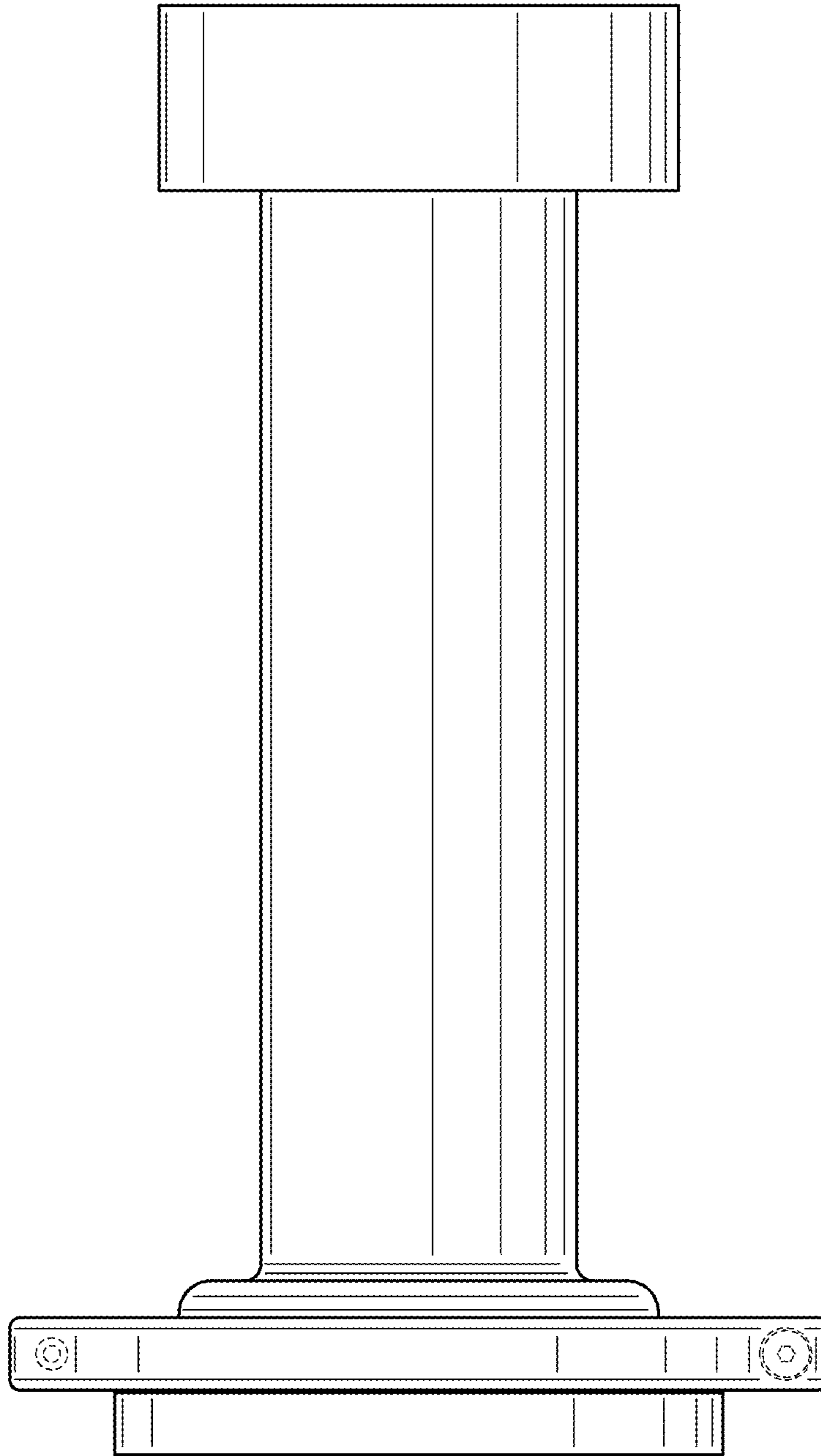

FIG. 4

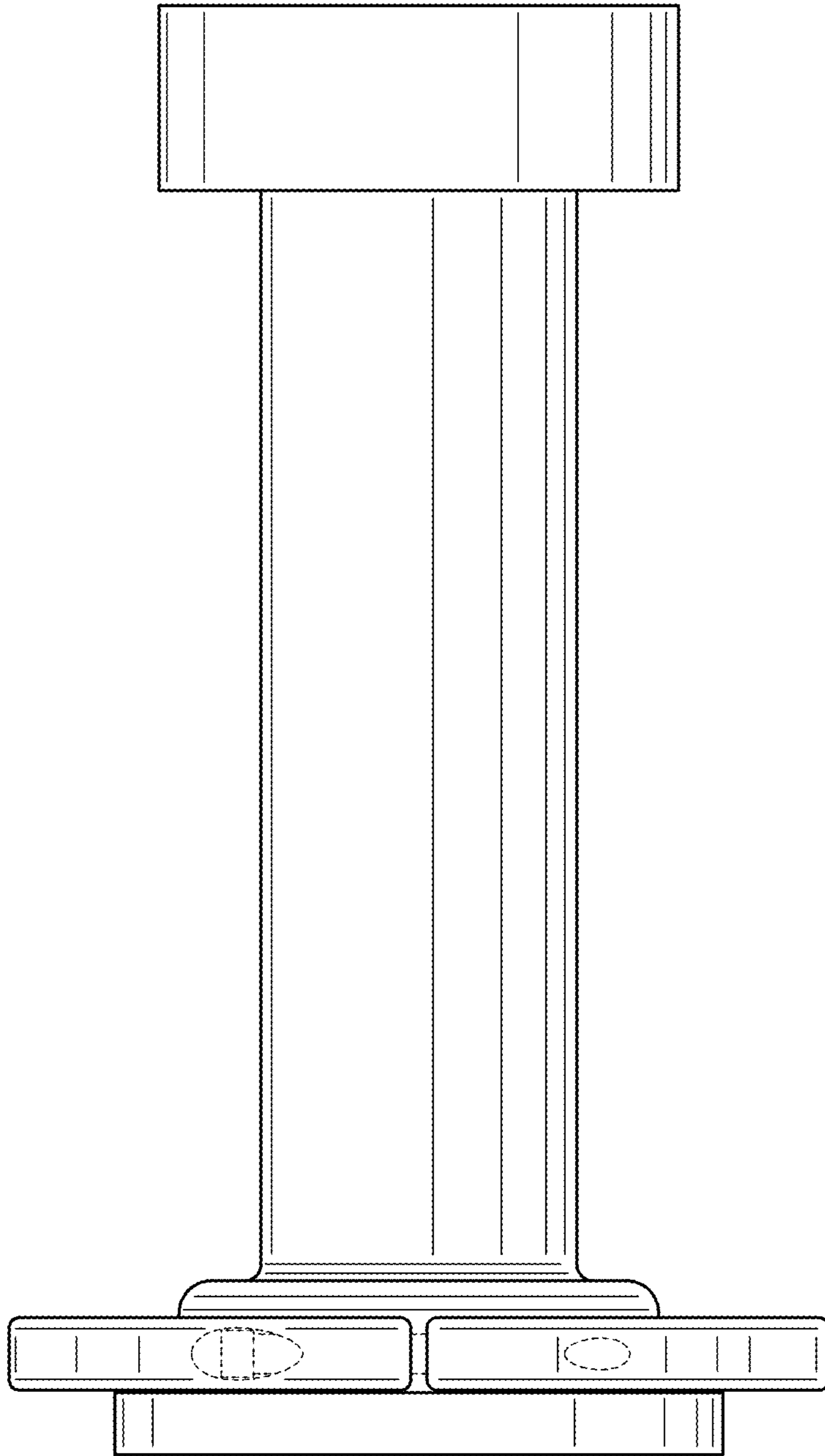

FIG.5

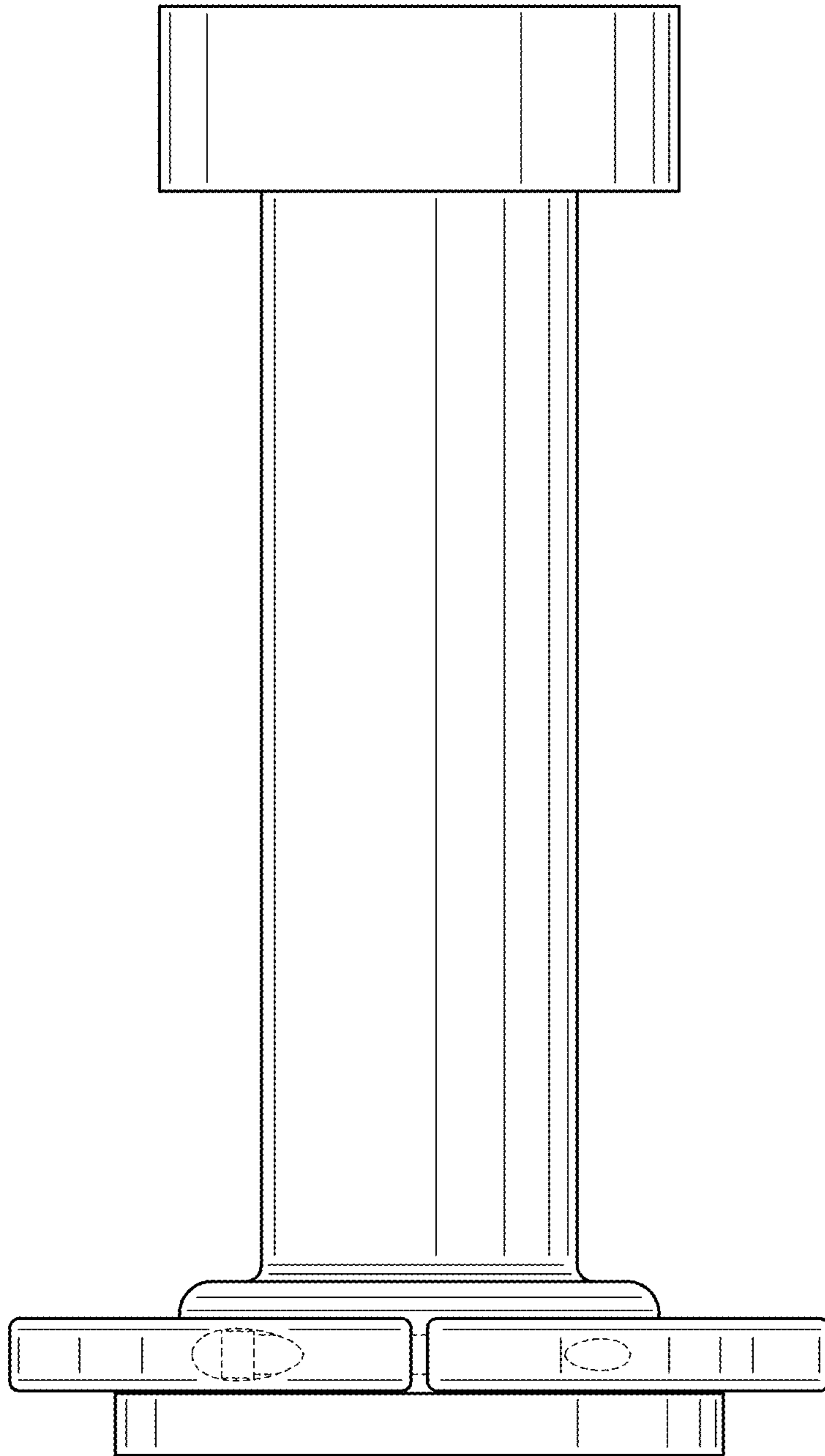

FIG.6

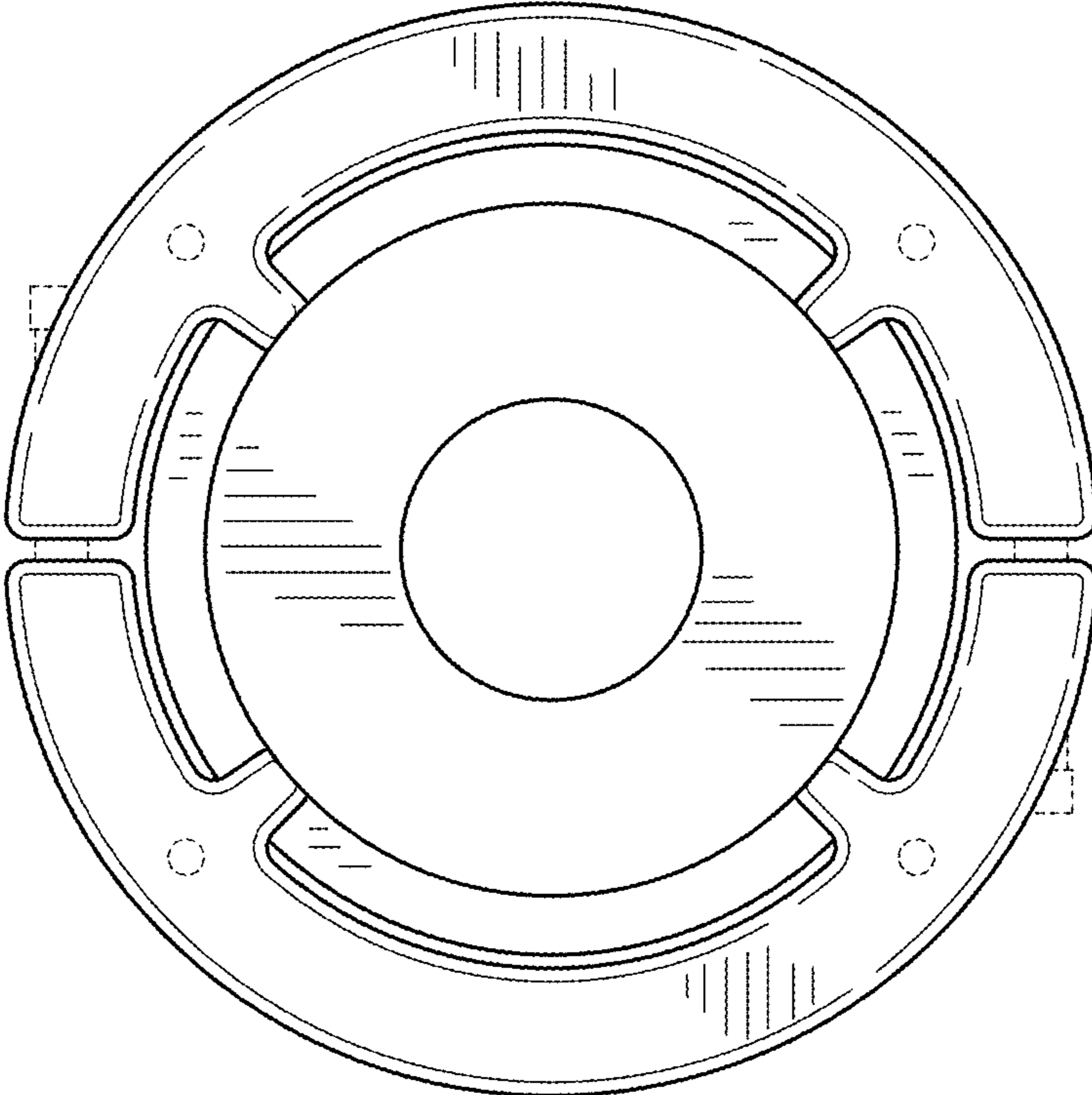

FIG.7

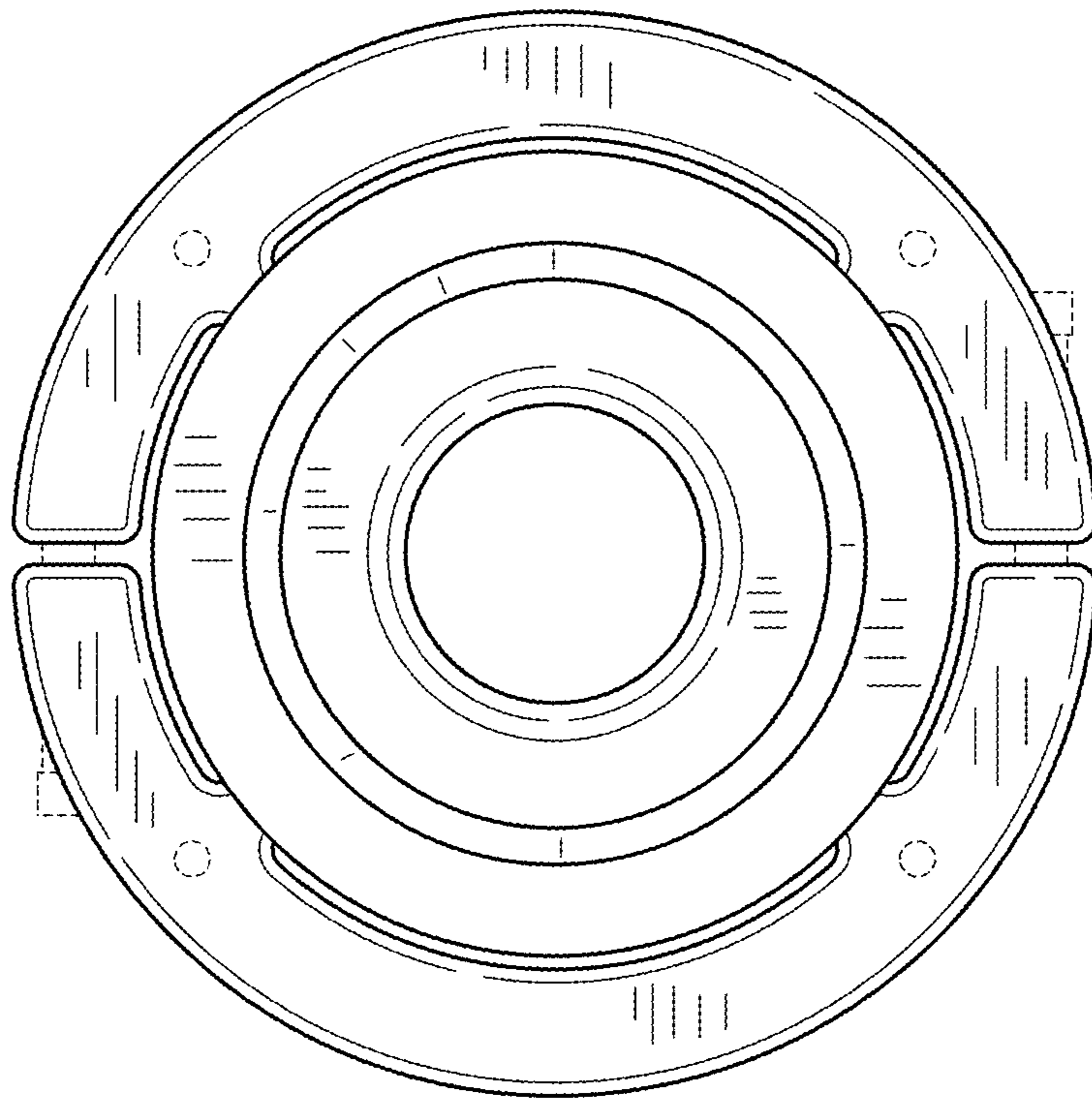

FIG.8