



US00D903417S

(12) **United States Design Patent**  
**Maister**

(10) **Patent No.:** **US D903,417 S**

(45) **Date of Patent:** **\*\* Dec. 1, 2020**

(54) **MEAT CLAMP**

(71) Applicant: **Brett Maister**, Santa Ana, CA (US)

(72) Inventor: **Brett Maister**, Santa Ana, CA (US)

(\*\*) Term: **15 Years**

(21) Appl. No.: **29/689,459**

(22) Filed: **Apr. 30, 2019**

(51) **LOC (12) Cl.** ..... **07-02**

(52) **U.S. Cl.**  
USPC ..... **D7/409**

(58) **Field of Classification Search**

USPC ..... D7/409, 402, 412, 683

CPC ..... A47J 37/04; A47J 37/041; A47J 37/042;

A47J 37/049; A47J 37/043; A47J 37/0763

See application file for complete search history.

D336,593 S	6/1993	Yeuan	
D377,888 S	2/1997	Griffin	
D409,047 S	5/1999	Battioli	
6,509,549 B1 *	1/2003	Chasen	..... A47J 37/041 219/386
D479,948 S	9/2003	Deary	
D519,331 S	4/2006	Camp	
D519,793 S	5/2006	Hutzler	
D528,872 S	9/2006	Wall	
D617,601 S	6/2010	Peterson	
D637,050 S	5/2011	Johnson, Jr.	
D651,484 S	1/2012	Zemel	
D657,207 S	4/2012	Habig et al.	
D663,171 S	7/2012	Borovicka et al.	
D685,617 S	7/2013	Zemel et al.	
D712,708 S	9/2014	High	

\* cited by examiner

*Primary Examiner* — Terry A Wallace

(74) *Attorney, Agent, or Firm* — Dunlap Bennett & Ludwig, PLLC

(56) **References Cited**

**U.S. PATENT DOCUMENTS**

1,384,250 A *	7/1921	Froom	..... A47J 33/00 126/30
1,723,597 A	8/1929	Bannister	
2,231,098 A	2/1941	Tourot	
D152,117 S	12/1948	Morfesi	
3,248,518 A *	4/1966	Ogle, Jr.	..... A47J 37/041 219/450.1
3,387,555 A *	6/1968	Moran	..... A47J 37/041 99/421 R
3,946,653 A *	3/1976	Pugh	..... A47J 37/0763 99/340
4,208,959 A *	6/1980	Schmidt	..... A47J 37/0704 99/339
D261,092 S	10/1981	Menard	
D262,347 S	12/1981	Bourne et al.	
D286,256 S	10/1986	Jung	

(57) **CLAIM**

The ornamental design for a meat clamp, as shown and described.

**DESCRIPTION**

FIG. 1 is a perspective view of a meat clamp; FIG. 2 is a front elevation view thereof; FIG. 3 is a rear elevation view thereof; FIG. 4 is a right side elevation view thereof; FIG. 5 is a left side elevation view thereof; FIG. 6 is a top plan view thereof; and, FIG. 7 is a bottom plan view thereof. The broken lines shown in the drawings depict a portion of a meat clamp that forms no part of the claimed invention.

**1 Claim, 4 Drawing Sheets**

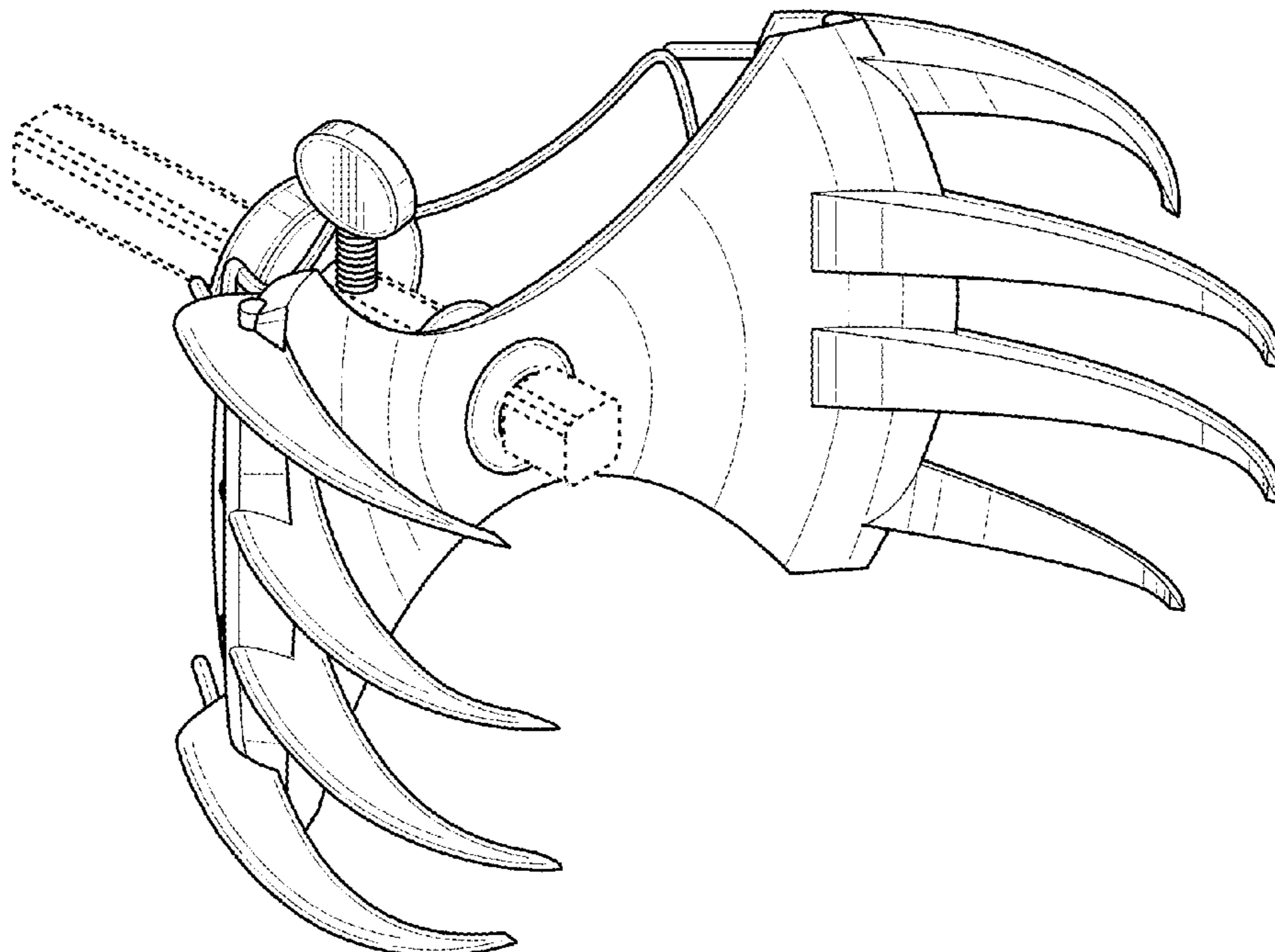

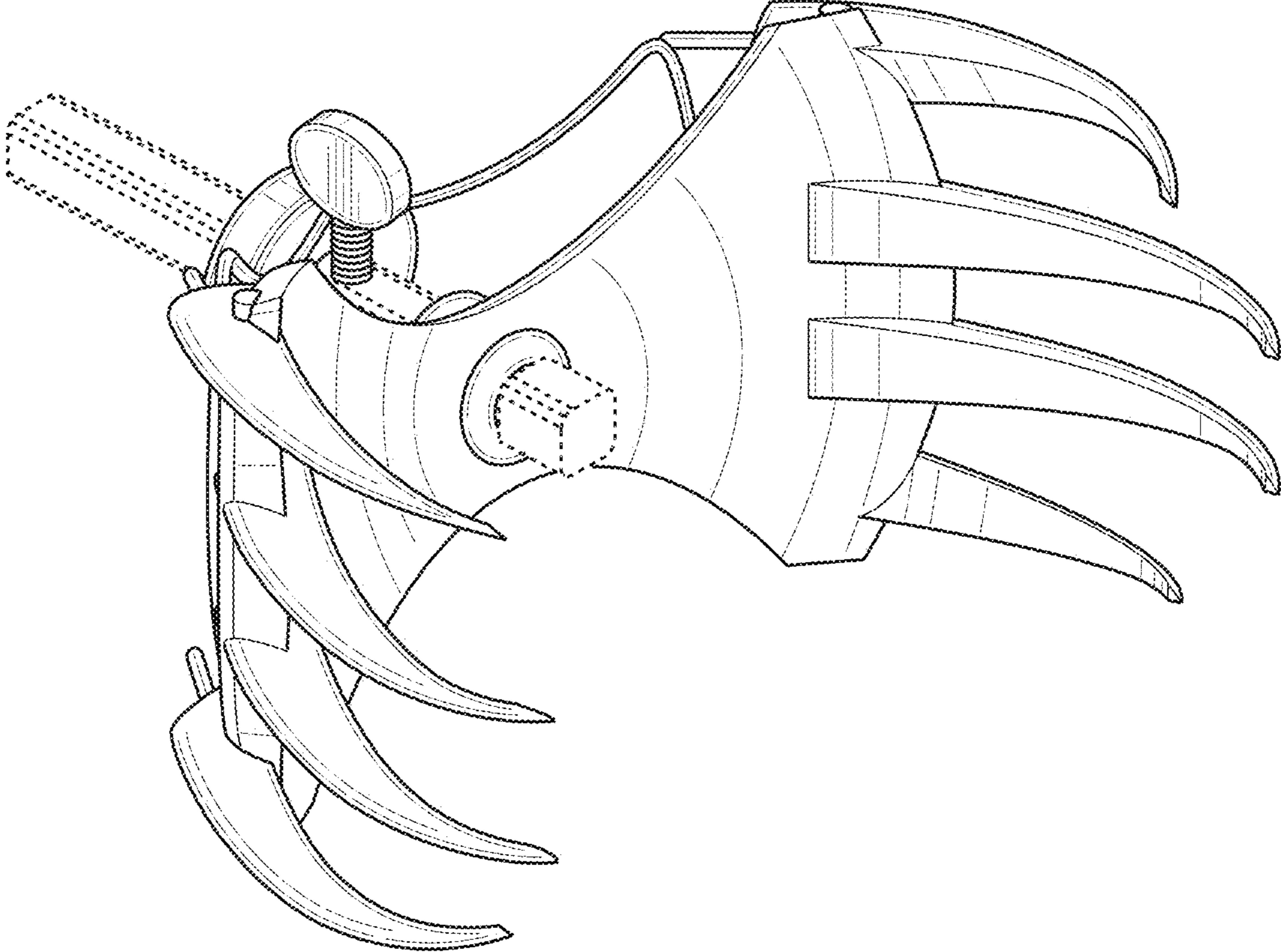
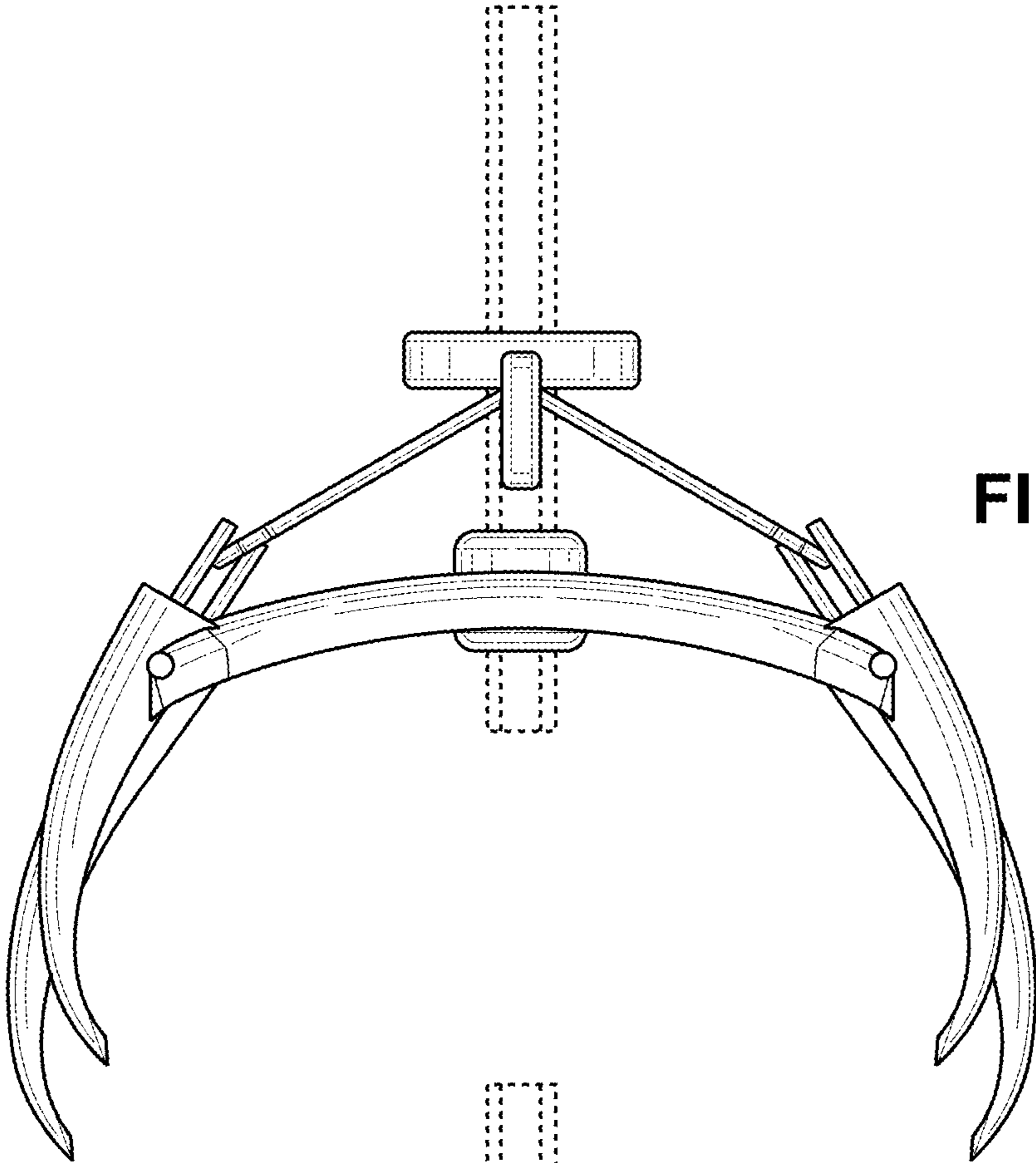
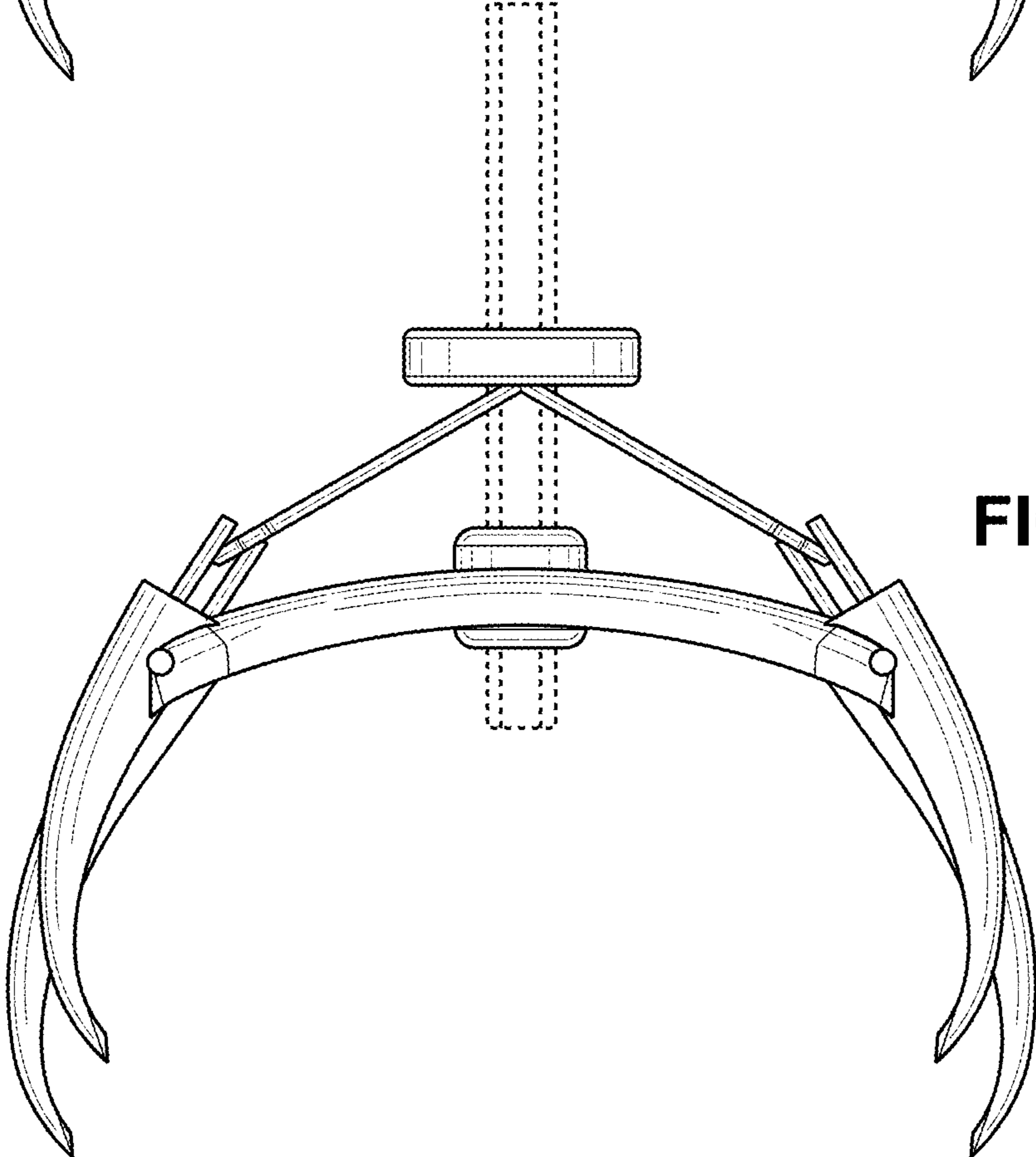

FIG. 1



**FIG. 2**



**FIG. 3**

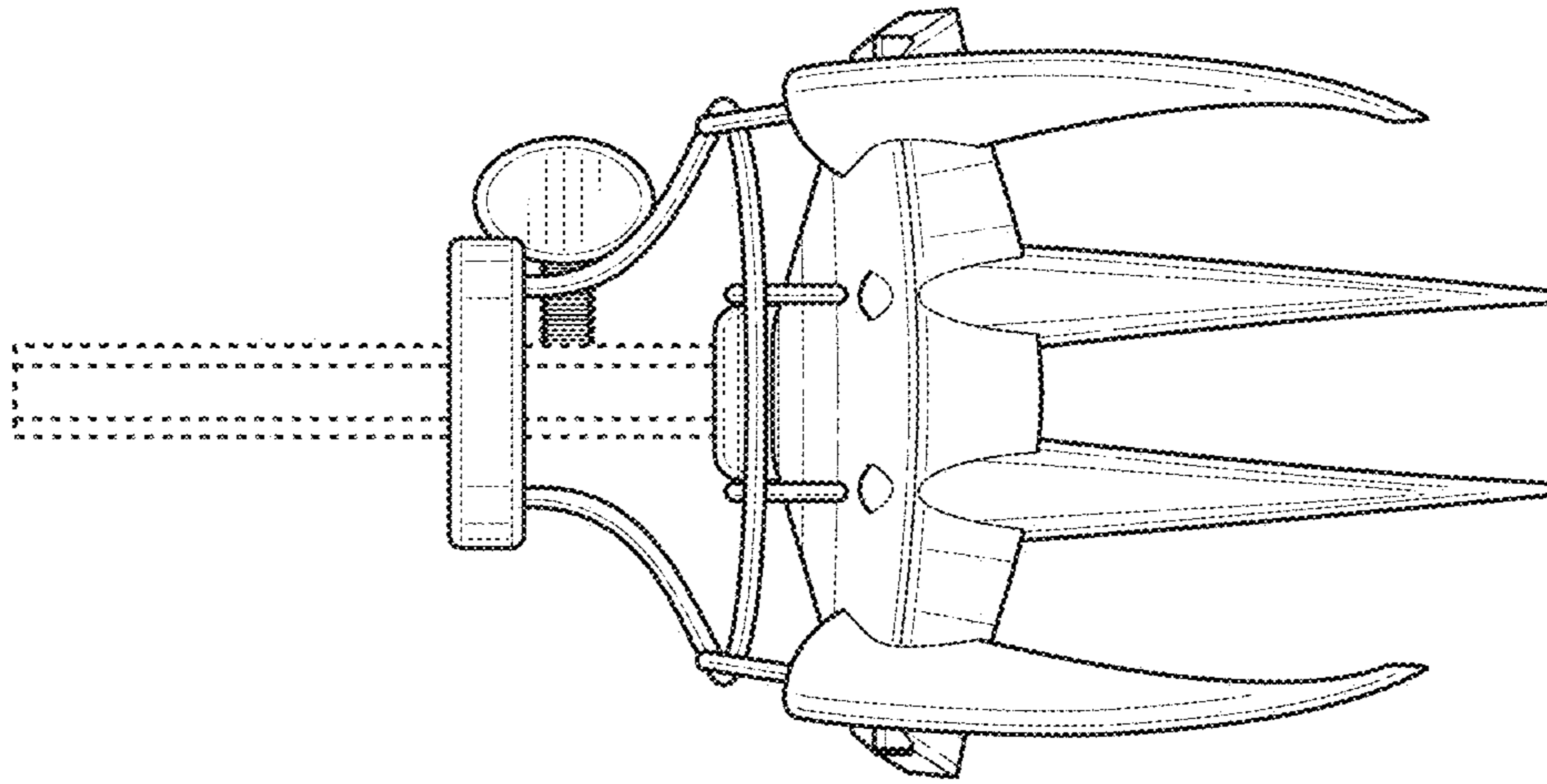

FIG. 4

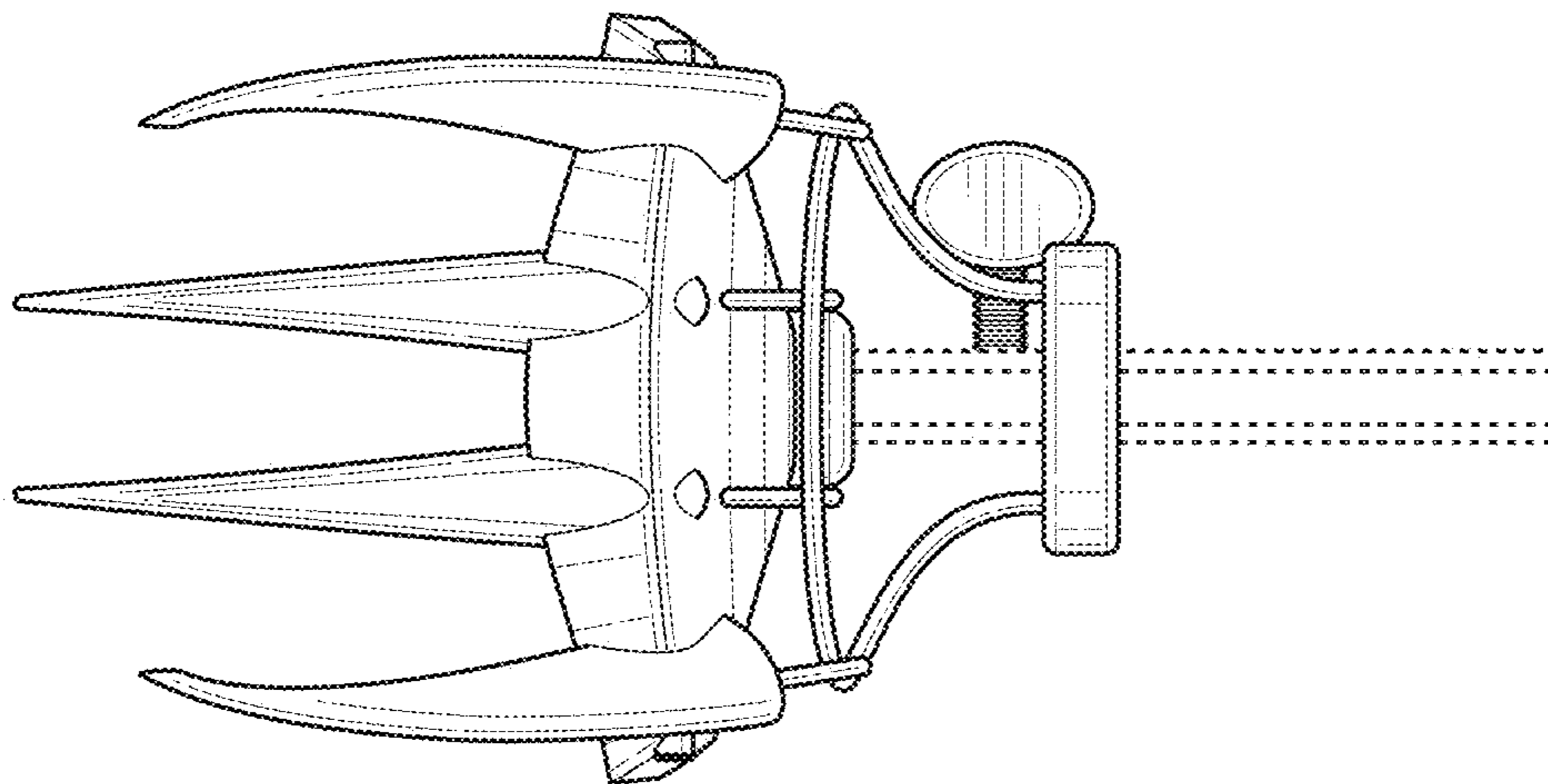

FIG. 5

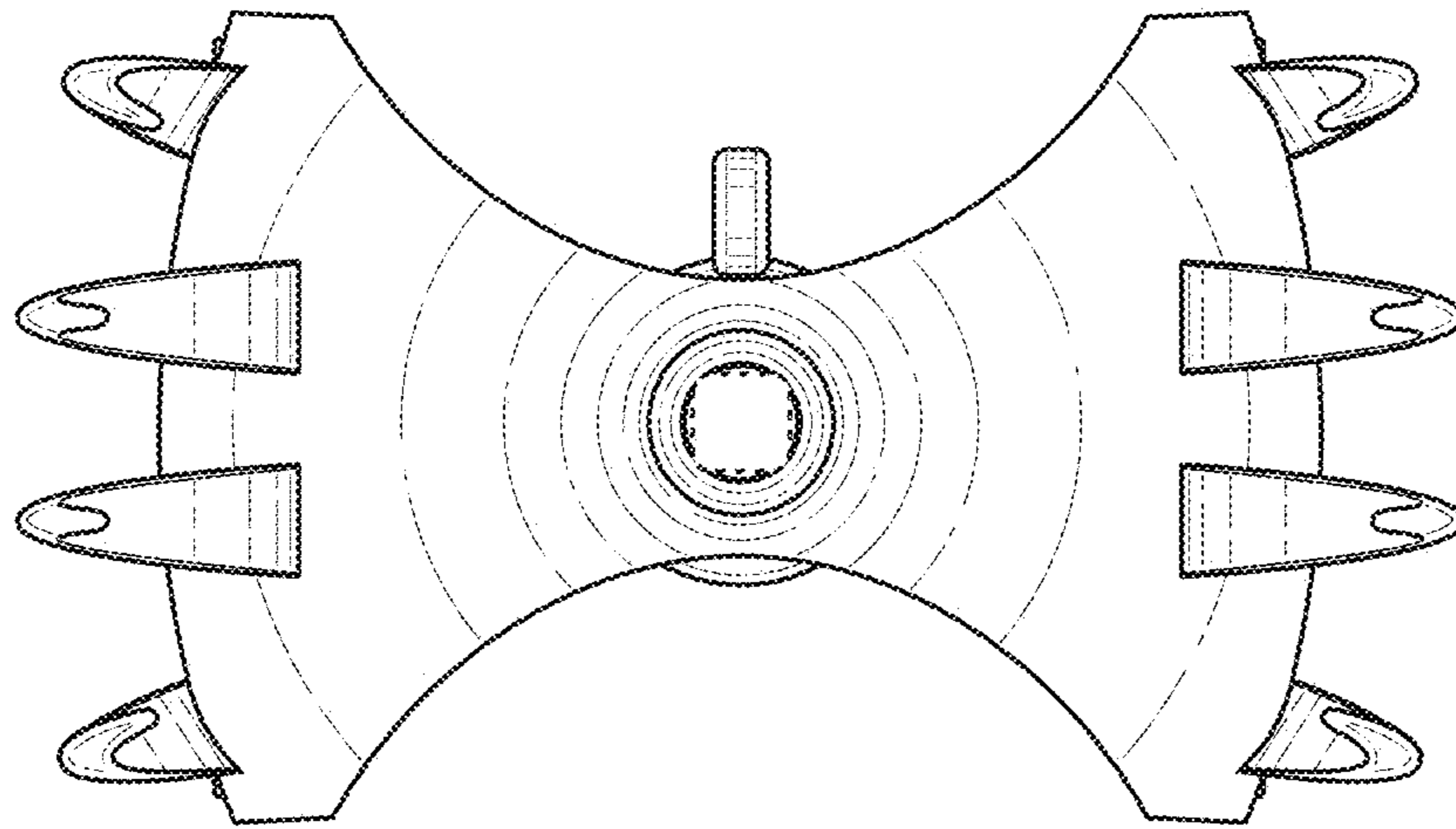

FIG. 6

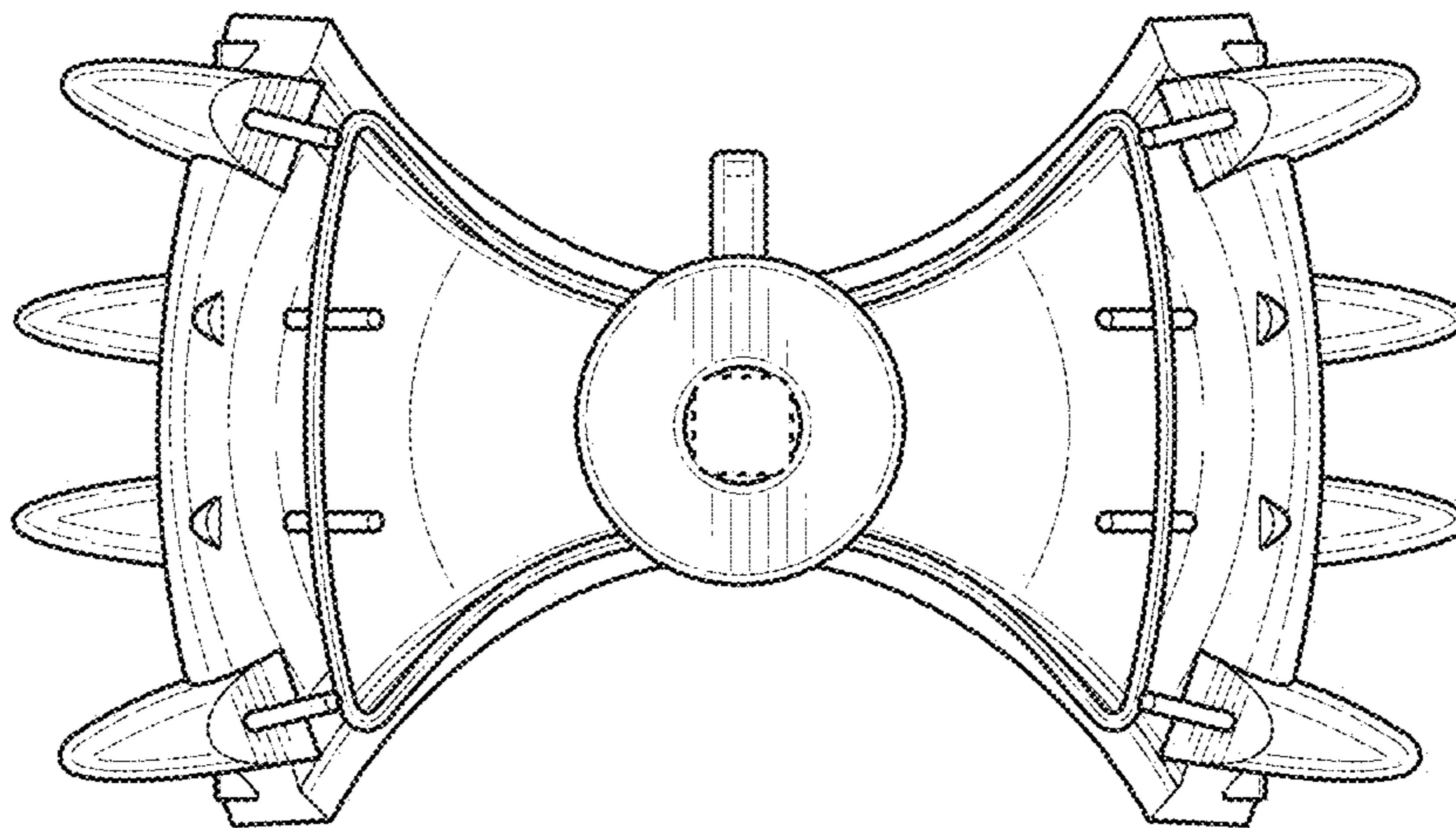

FIG. 7