



US00D903158S

(12) **United States Design Patent** (10) **Patent No.:** **US D903,158 S**
Platto et al. (45) **Date of Patent:** **** Nov. 24, 2020**

(54) **VEHICLE HEADLIGHT**
(71) Applicant: **Ford Global Technologies, LLC**,
Dearborn, MI (US)
(72) Inventors: **Gordon Platto**, Troy, MI (US); **Sean Tant**, Livonia, MI (US); **Joshua Henry**,
Detroit, MI (US)
(73) Assignee: **Ford Global Technologies, LLC**,
Dearborn, MI (US)

D771,850 S	11/2016	Platto et al.	
D842,503 S *	3/2019	Yang	D26/28
D849,285 S *	5/2019	Lin	D26/28
D855,849 S *	8/2019	Lin	D26/28
D863,622 S *	10/2019	Wu	D26/28
D863,627 S *	10/2019	Lin	D26/28
D863,628 S *	10/2019	Lin	D26/28
D869,700 S *	12/2019	Lin	D26/28
D874,034 S *	1/2020	Schmeckpeper	D26/28
D874,039 S *	1/2020	He	D26/28
D874,040 S *	1/2020	He	D26/28
D875,281 S *	2/2020	Schmeckpeper	D26/28

(**) Term: **15 Years**

* cited by examiner

Primary Examiner — Angela J Lee

(21) Appl. No.: **29/678,064**

(22) Filed: **Jan. 25, 2019**

(51) **LOC (12) Cl.** **26-06**

(52) **U.S. Cl.**
USPC **D26/28**

(58) **Field of Classification Search**
USPC D26/28-36; 362/459-468, 475-478,
362/485-487

CPC F21S 48/00; F21S 48/10; F21S 48/115;
F21S 48/225; F21S 48/1233; F21S
48/1266; F21S 48/1388; F21S 48/2268;
F21V 21/04

See application file for complete search history.

(56) **References Cited**

U.S. PATENT DOCUMENTS

D535,045 S	1/2007	Schiavone et al.	
D604,874 S	11/2009	Golden et al.	
D769,480 S *	10/2016	Lai	D26/28
D771,291 S *	11/2016	Tsai	D26/28

(57) **CLAIM**

The ornamental design for a vehicle headlight, as shown and described.

DESCRIPTION

FIG. 1 is a front elevational view of a vehicle headlight, showing our new design;
FIG. 2 is a left side elevational view thereof;
FIG. 3 is a right side elevational view thereof;
FIG. 4 is a top plan view thereof;
FIG. 5 is a bottom plan view thereof;
FIG. 6 is a top, front and left side perspective view thereof;
and,
FIG. 7 is a bottom, front and left side perspective view thereof.

The broken lines represent an internal boundary of the design; the line itself and the lighter gray shaded areas to the rear of the broken line form no part of the claimed design.

1 Claim, 7 Drawing Sheets

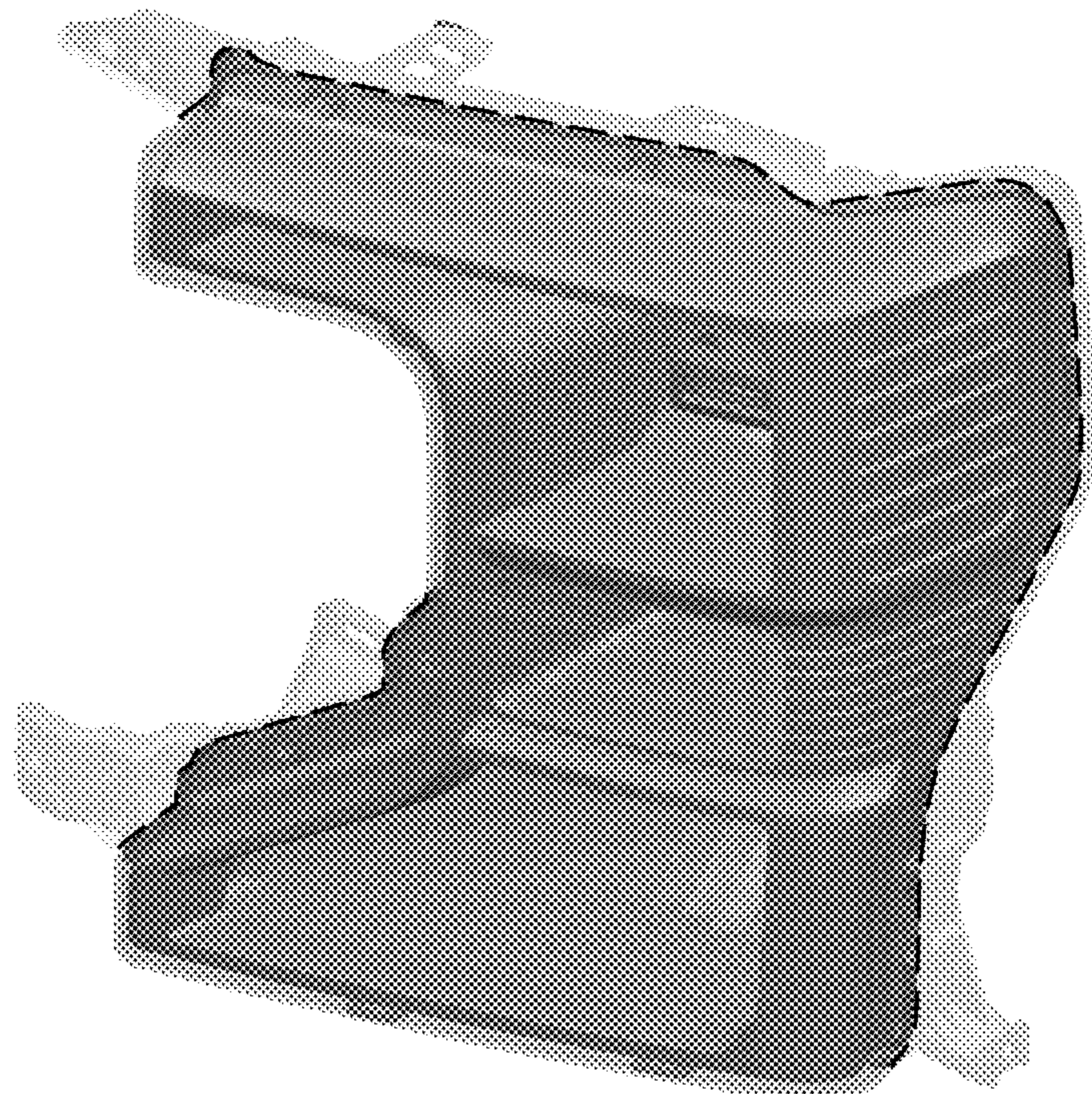

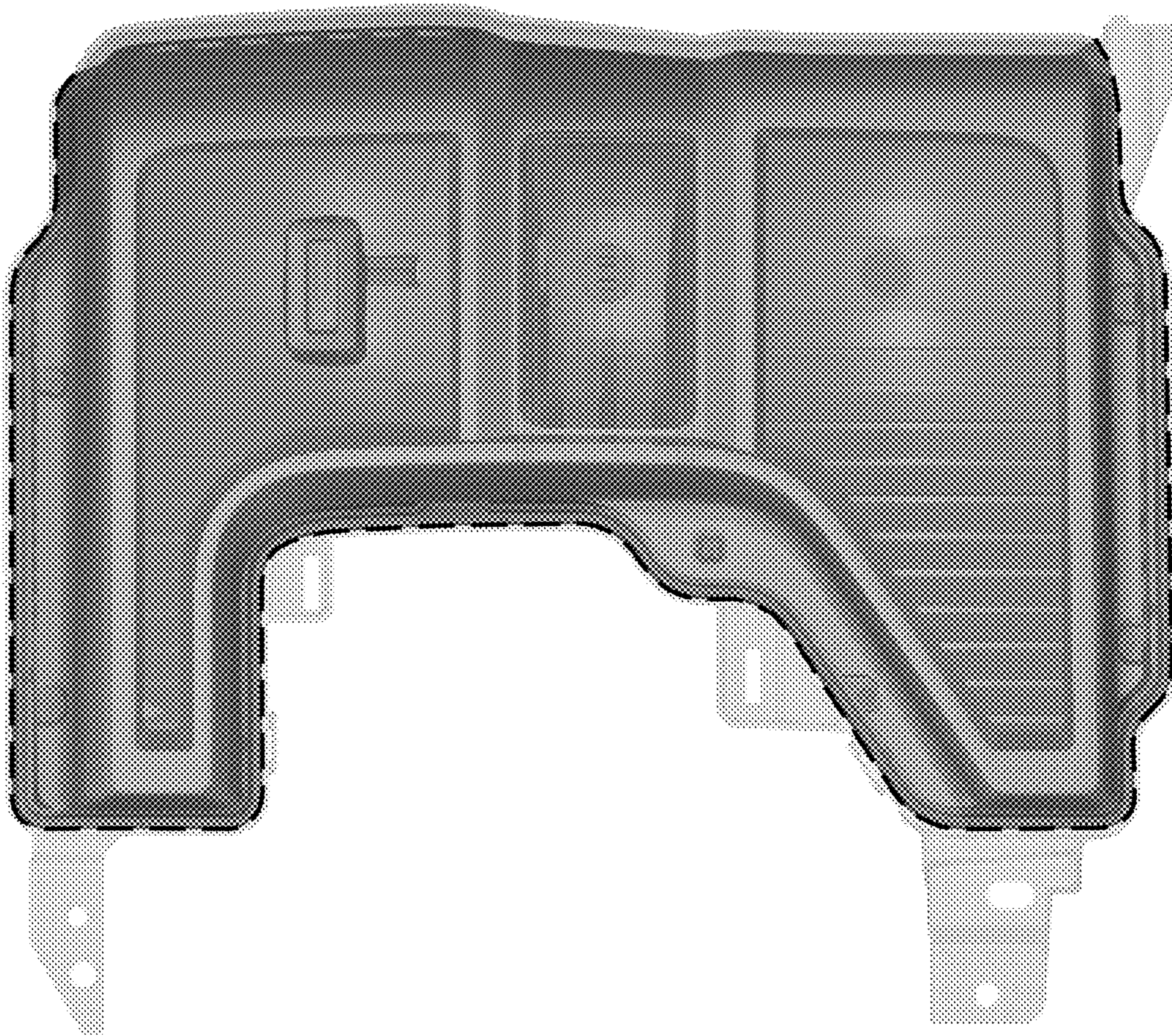

Fig.1

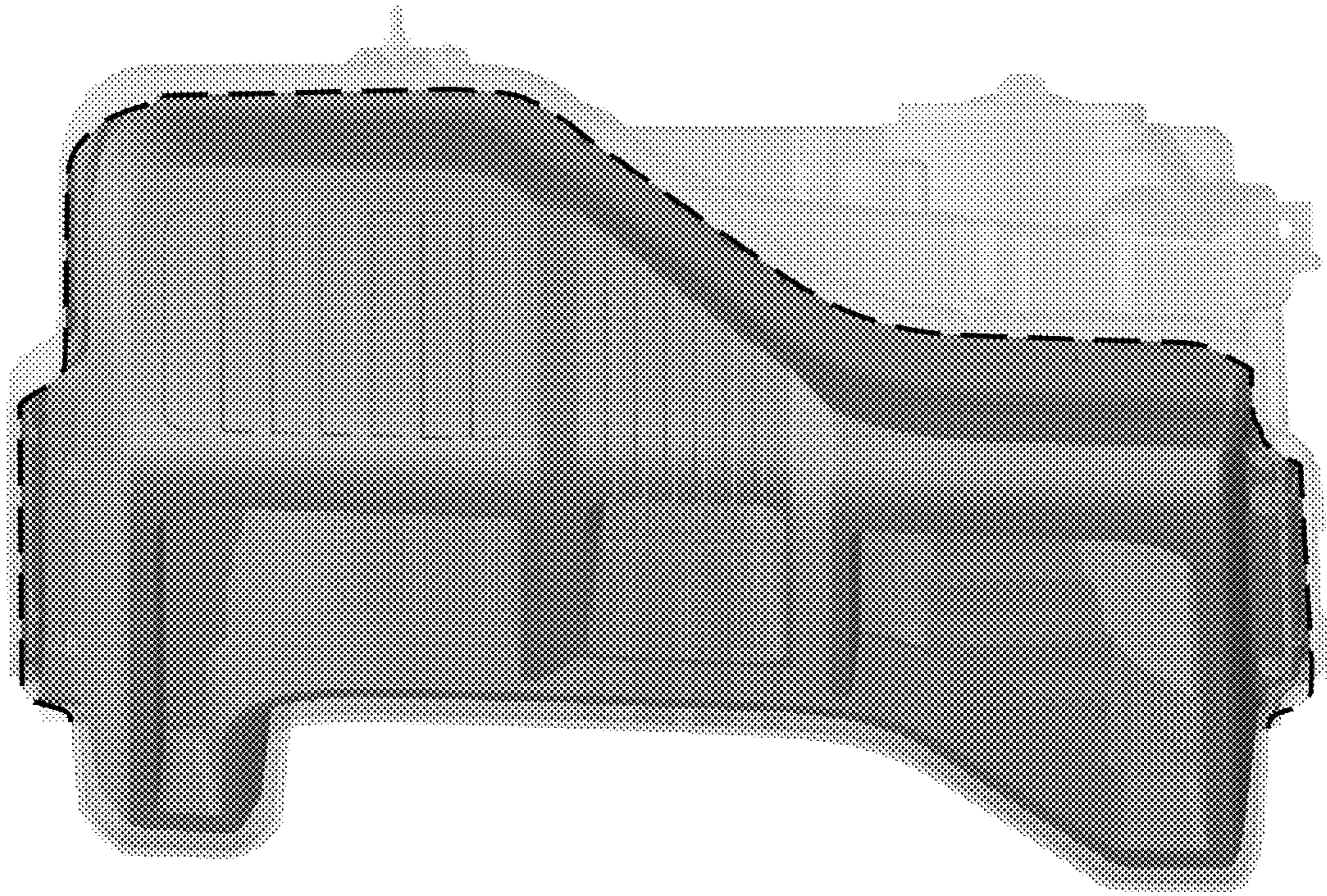

Fig.2

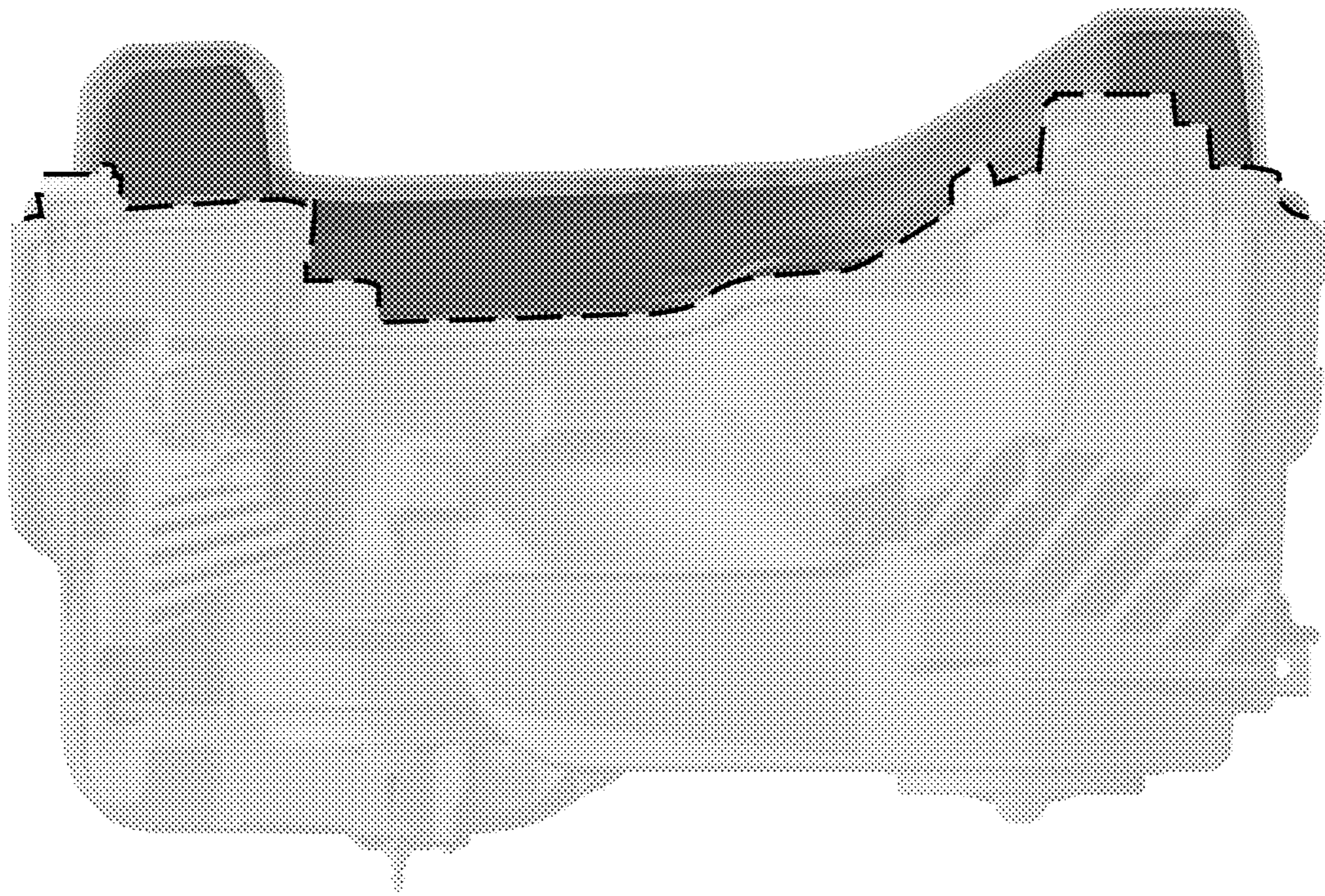

Fig. 3

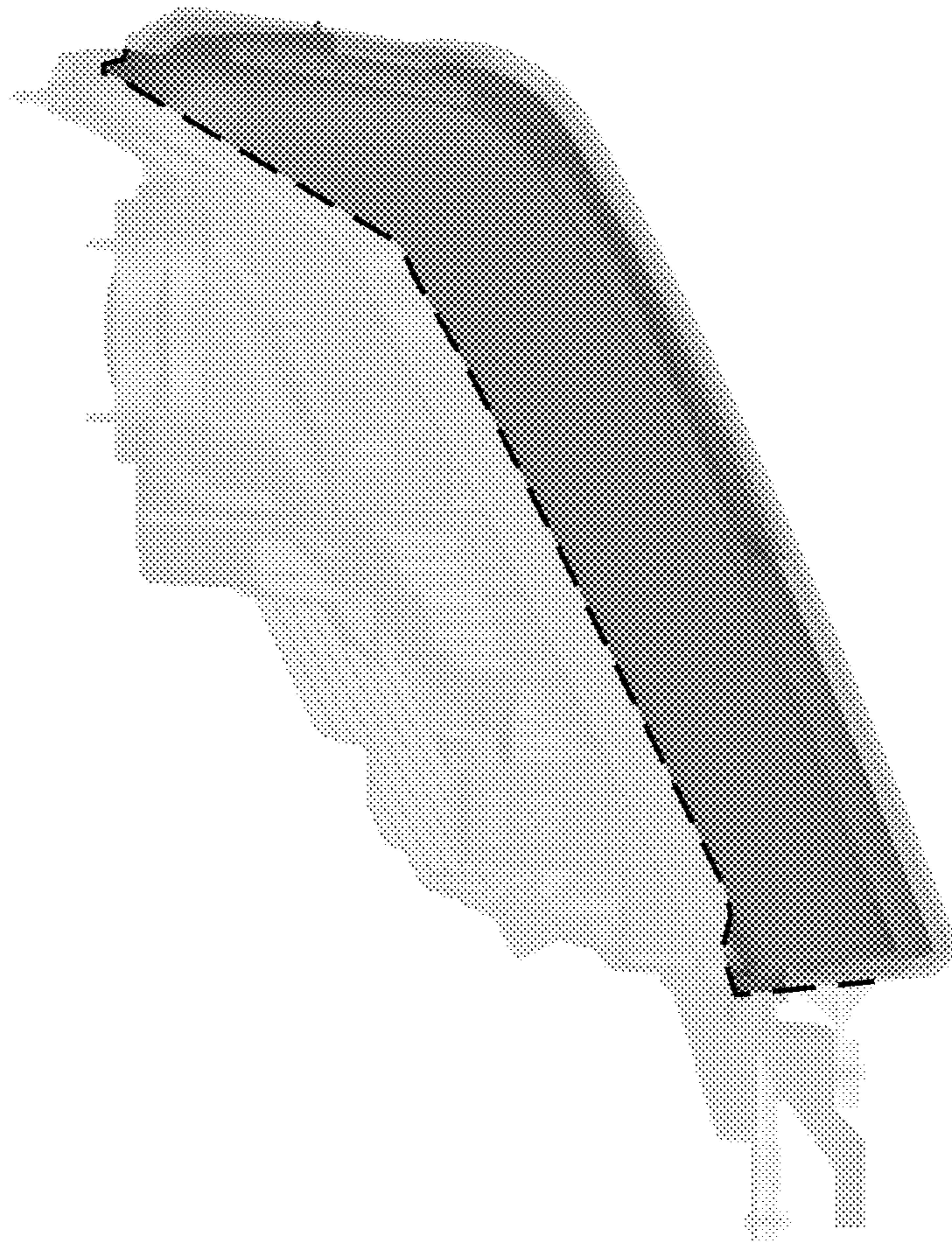
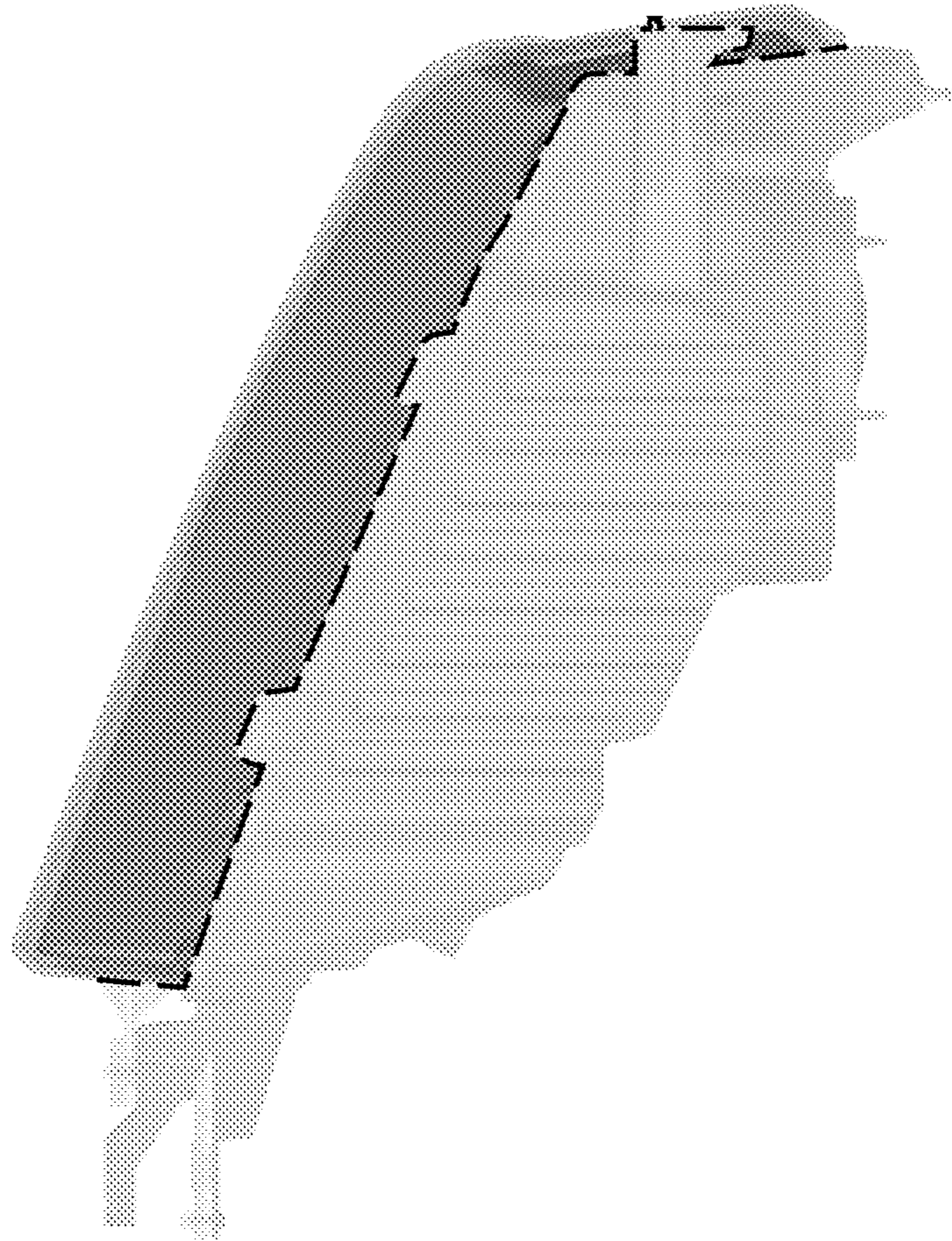

Fig.4

Fig. 5



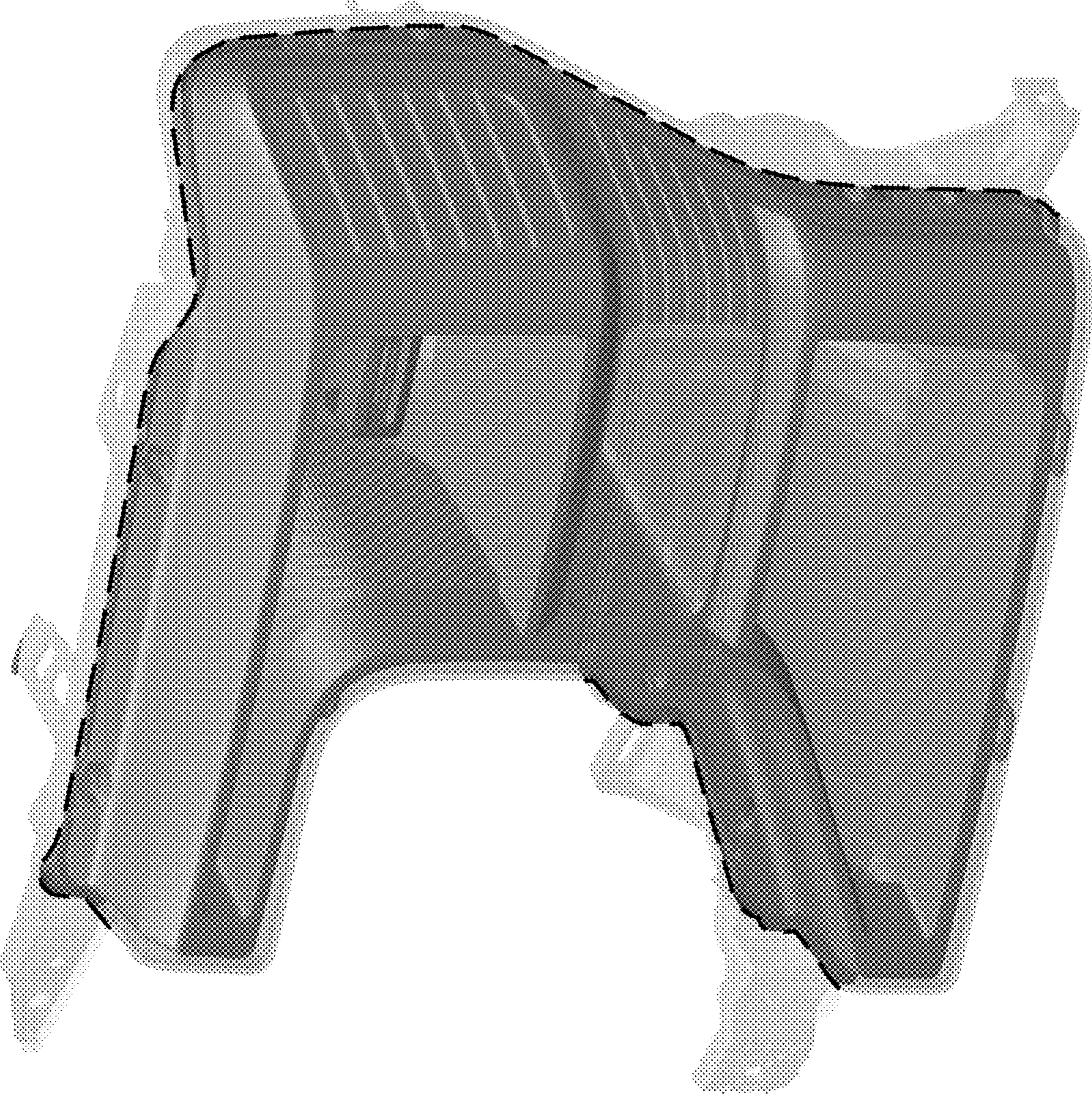

Fig.6

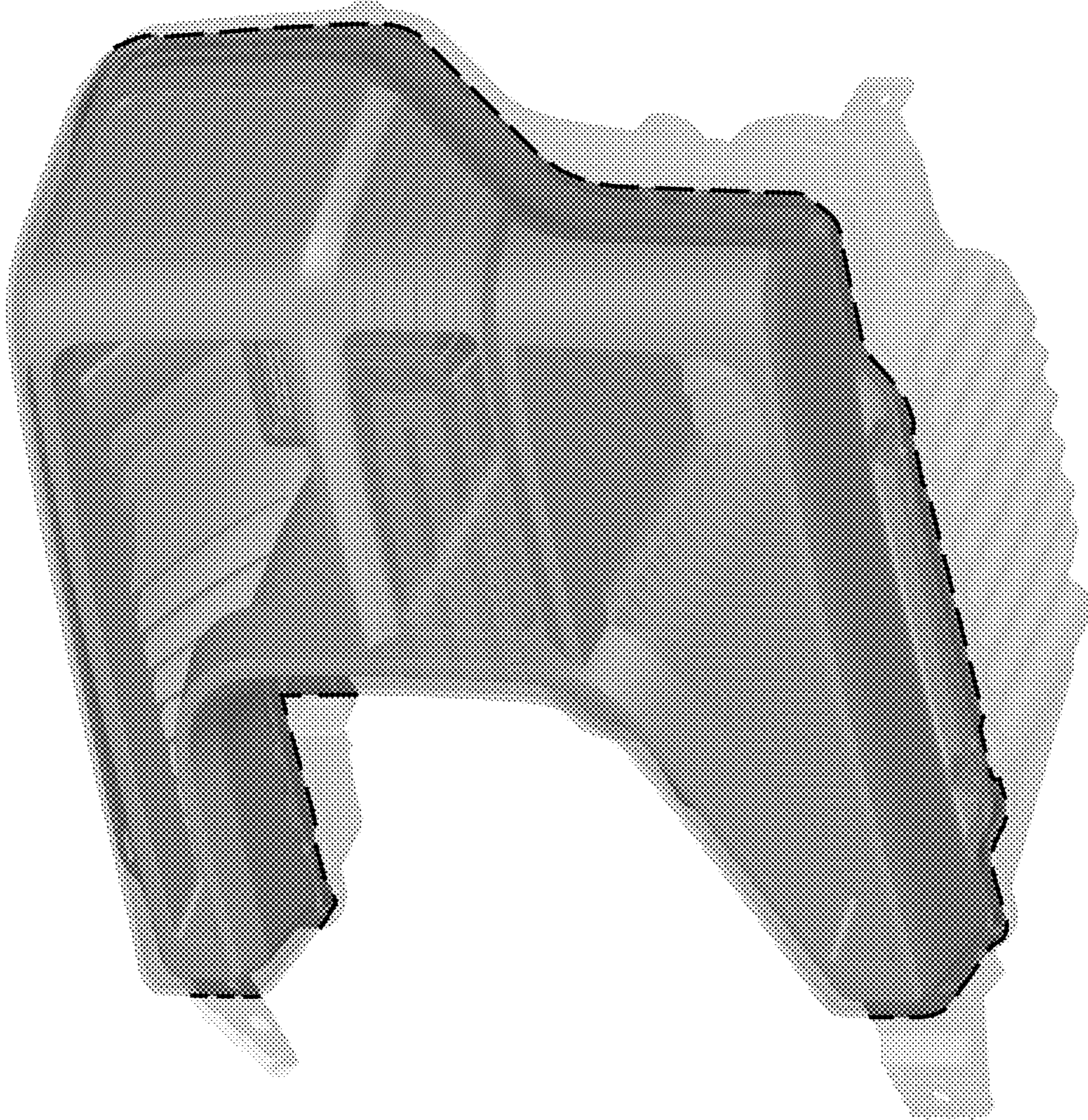

Fig. 7