



US00D903075S

(12) **United States Design Patent**  
**Huang et al.**

(10) **Patent No.:** **US D903,075 S**

(45) **Date of Patent:** **\*\* Nov. 24, 2020**

(54) **DOUBLE LAYER STRUCTURE OF THE CONDENSER**

(71) Applicant: **INSTITUTE OF NUCLEAR ENERGY RESEARCH, ATOMIC ENERGY COUNCIL, EXECUTIVE YUAN, R.O.C., Taoyuan (TW)**

(72) Inventors: **Yi-Ya Huang, Taoyuan (TW); Chun-Yi Chen, Taoyuan (TW); Hwen-Fen Hong, Taoyuan (TW)**

(73) Assignee: **Institute of Nuclear Energy Research, Atomic Energy Council, Executive Yuan, R.O.C., Taoyuan (TW)**

(\*\*) Term: **15 Years**

(21) Appl. No.: **29/624,065**

(22) Filed: **Oct. 30, 2017**

(51) **LOC (12) Cl.** ..... **23-04**

(52) **U.S. Cl.**  
USPC ..... **D23/354**

(58) **Field of Classification Search**  
USPC ..... D23/333, 351–354, 388  
CPC .... F24F 1/00; F24F 1/0007; F24F 1/02; F24F 1/08; F24F 1/42; F24F 1/56; F24F 1/60; F24F 3/044; F24F 3/048; F24F 3/16; G05D 23/1905; G05D 23/1932; G05D 23/1902; G05D 23/1931; G05B 19/0426; G05B 19/409; G05B 15/02  
See application file for complete search history.

(56) **References Cited**

**U.S. PATENT DOCUMENTS**

D329,694 S \* 9/1992 Wimberly ..... D23/373  
D431,174 S \* 9/2000 Merideth ..... D8/354  
D514,221 S \* 1/2006 Vladika ..... D23/412  
D541,689 S \* 5/2007 Meyers ..... D10/118

D587,797 S \* 3/2009 Blanchard ..... D23/370  
D588,254 S \* 3/2009 Deng ..... D23/372  
D595,830 S \* 7/2009 Deng ..... D23/372  
D657,036 S \* 4/2012 Vetu ..... D23/364  
D706,916 S \* 6/2014 Penlesky ..... D23/370  
D713,950 S \* 9/2014 Jepson ..... D23/388  
D713,952 S \* 9/2014 Jepson ..... D23/388  
D713,953 S \* 9/2014 Jepson ..... D23/388  
D754,319 S \* 4/2016 Park ..... D23/385  
D785,772 S \* 5/2017 Bergin ..... D23/325  
D811,566 S \* 2/2018 Liu ..... D23/325  
D846,102 S \* 4/2019 Pellerin ..... D23/332  
D850,653 S \* 6/2019 Kopp ..... D25/48.7  
D873,984 S \* 1/2020 Fiser ..... D23/373

\* cited by examiner

*Primary Examiner* — Natasha Vujcic

(74) *Attorney, Agent, or Firm* — Rosenberg, Klein & Lee

(57) **CLAIM**

The ornamental design for a double layer structure of the condenser, as shown and described.

**DESCRIPTION**

FIG. 1 is a left front perspective view of a double layer structure of the condenser according to the present invention;  
FIG. 2 is a front view of a double layer structure of the condenser according to the present invention;  
FIG. 3 is a rear view of a double layer structure of the condenser according to the present invention;  
FIG. 4 is a left view of a double layer structure of the condenser according to the present invention;  
FIG. 5 is a right view of a double layer structure of the condenser according to the present invention;  
FIG. 6 is a top view of a double layer structure of the condenser according to the present invention; and,  
FIG. 7 is a bottom view of a double layer structure of the condenser according to the present invention.

**1 Claim, 7 Drawing Sheets**

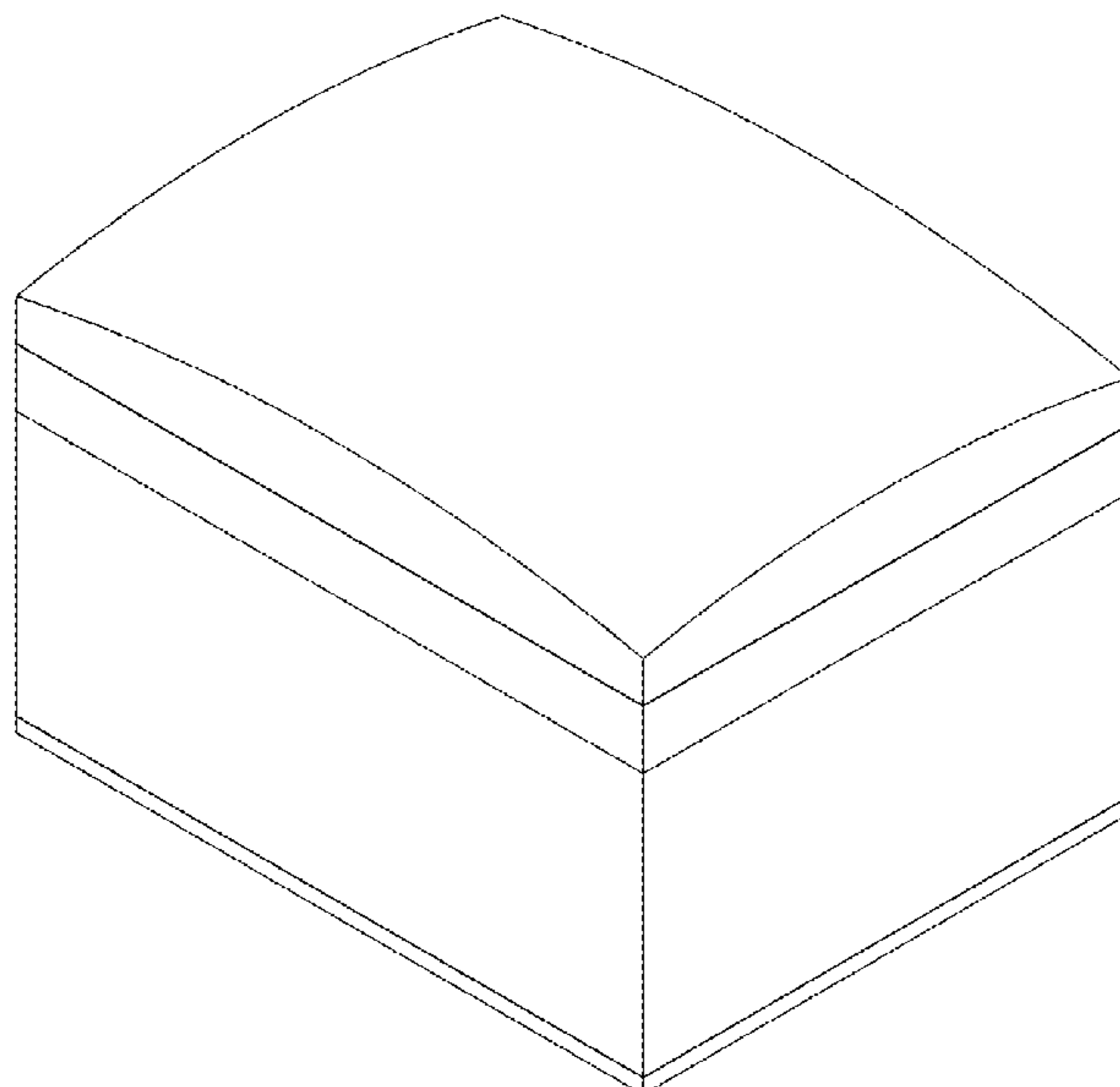

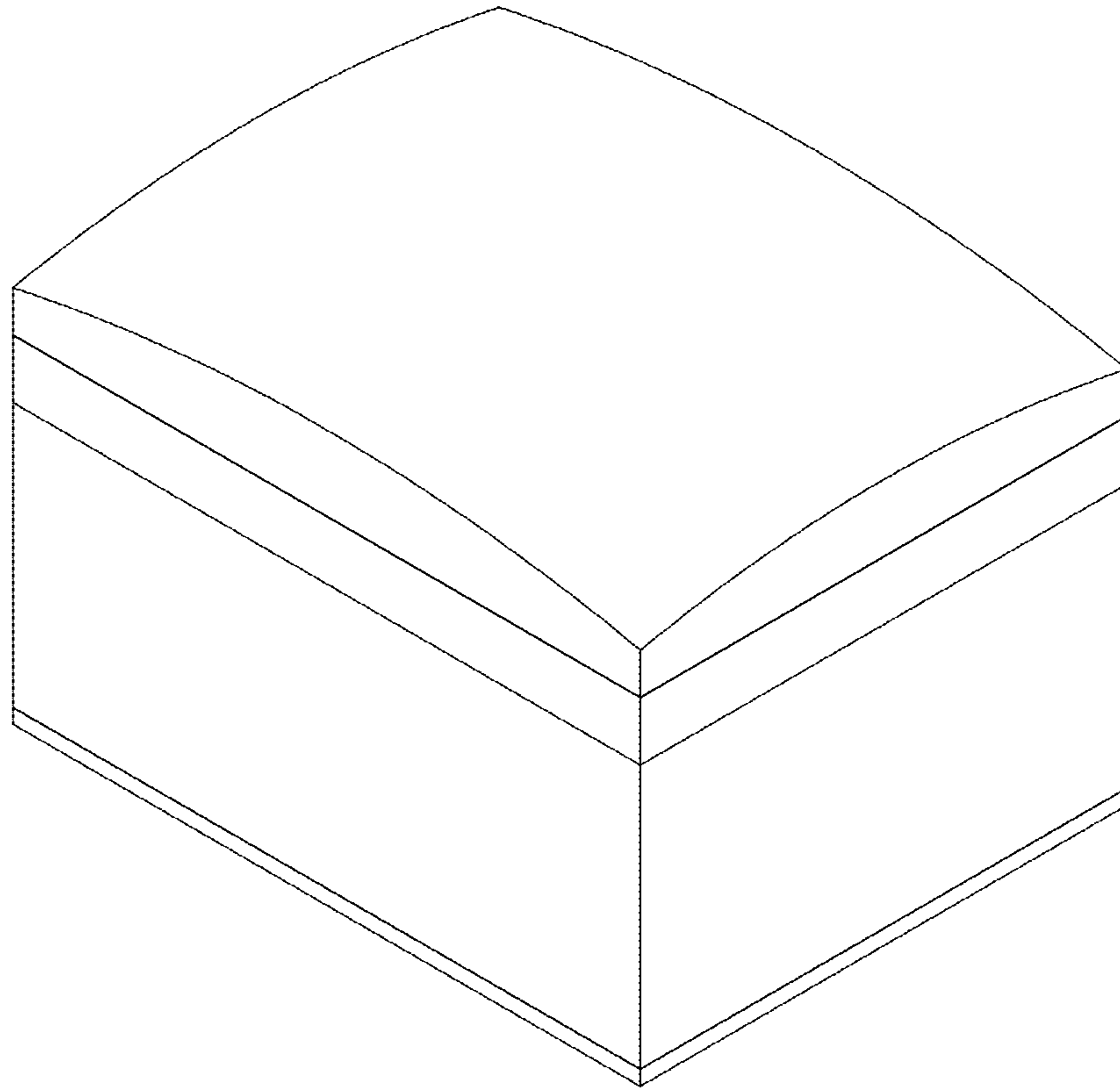

Figure 1

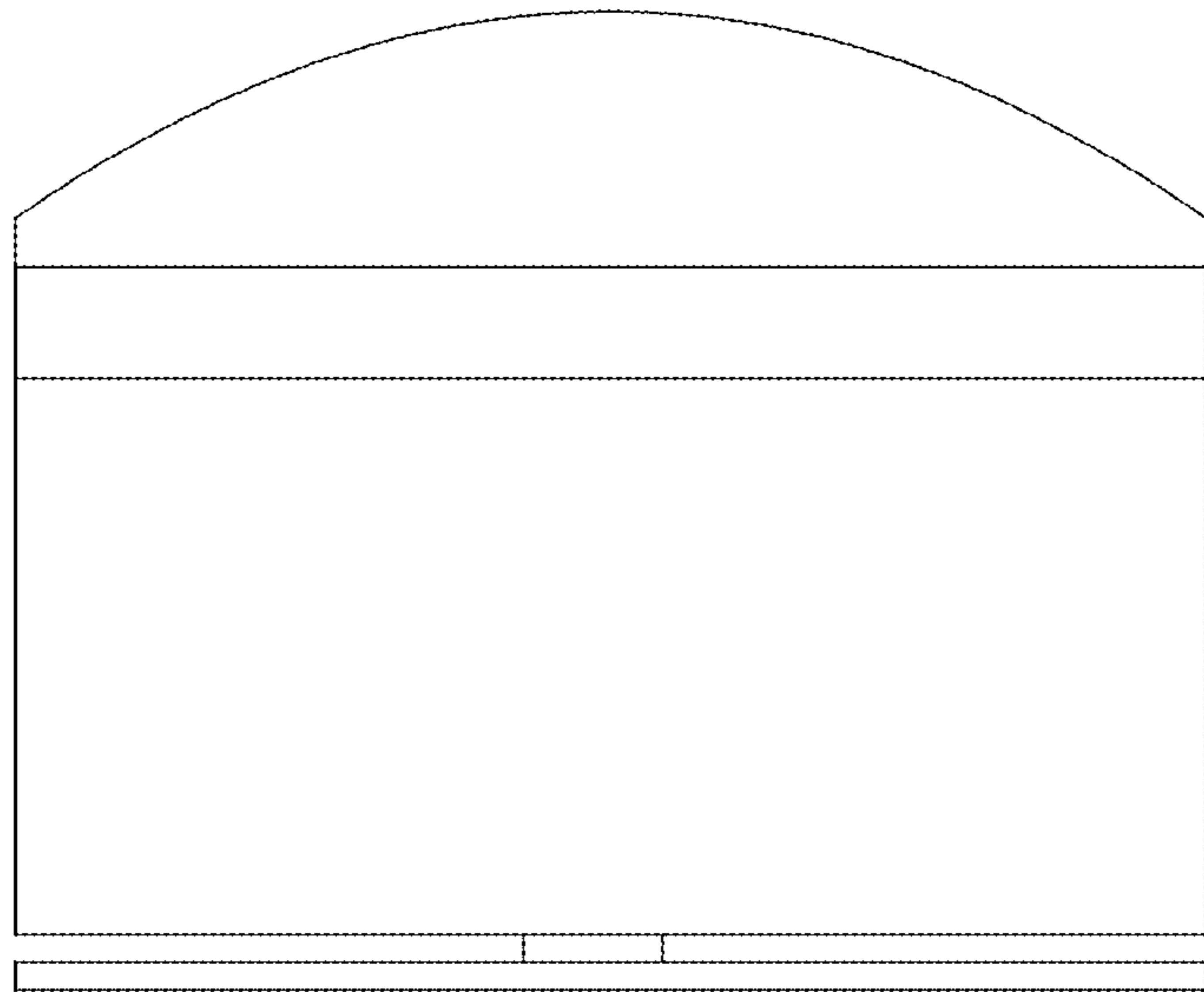

Figure 2

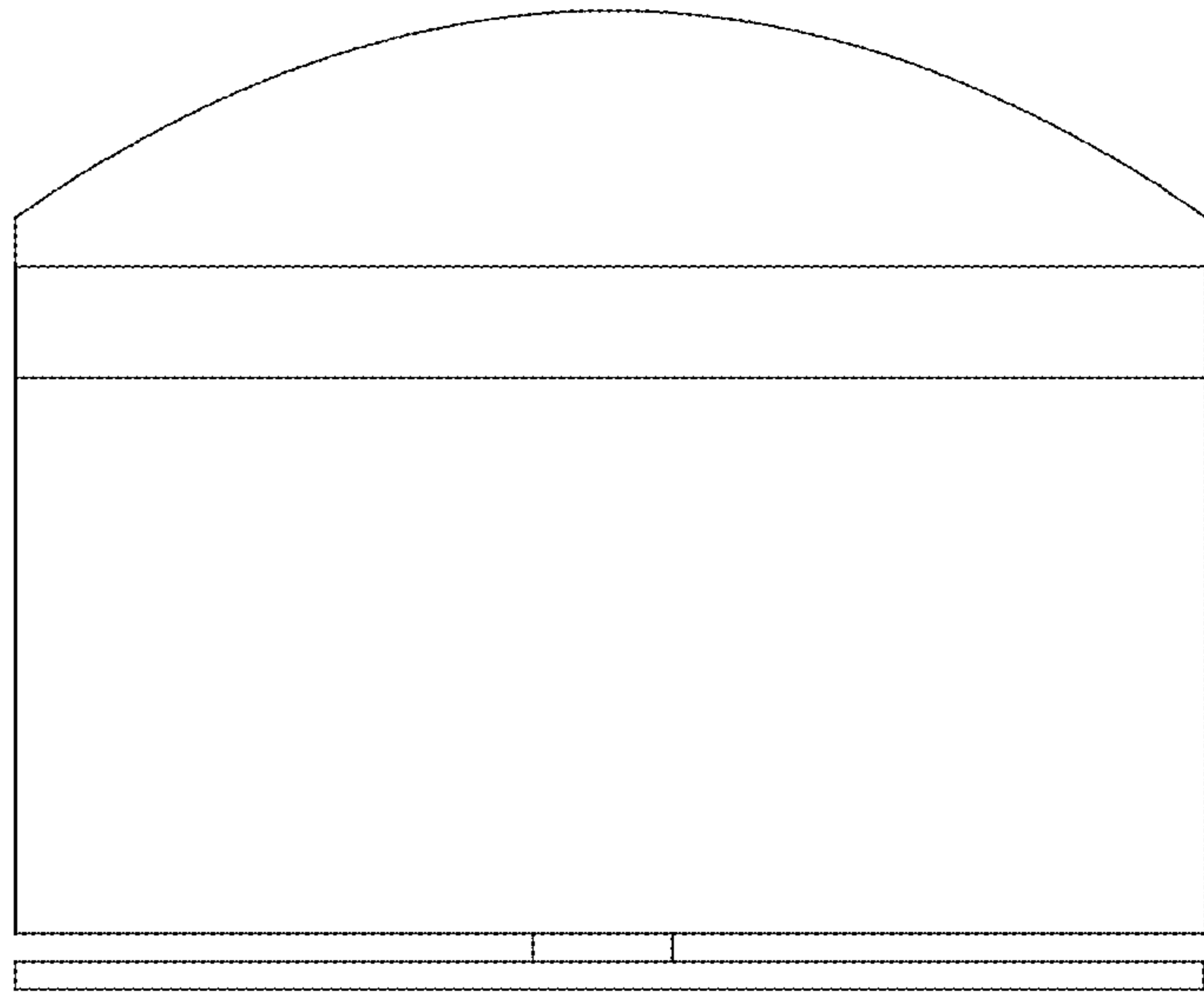

Figure 3

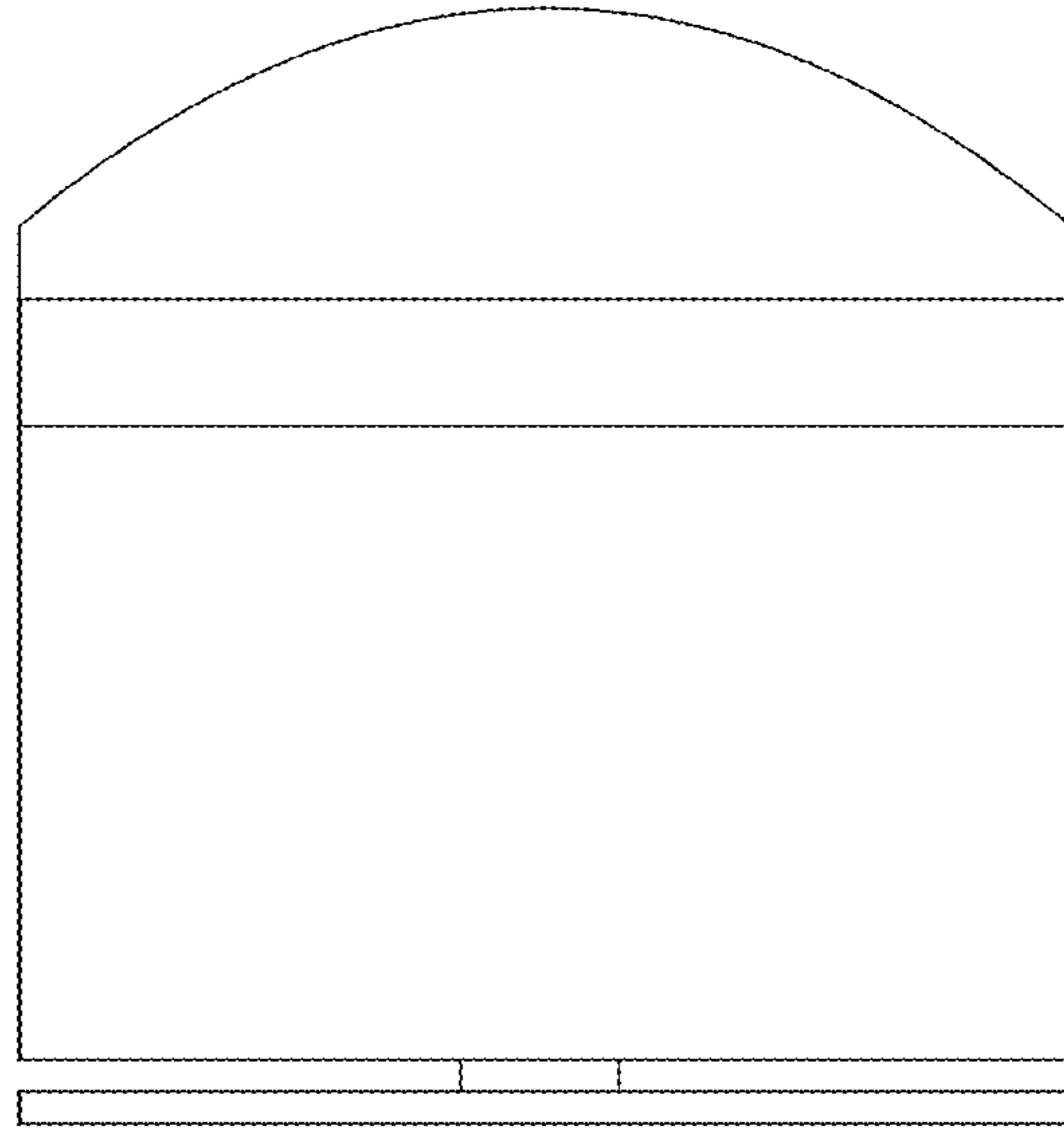

Figure 4

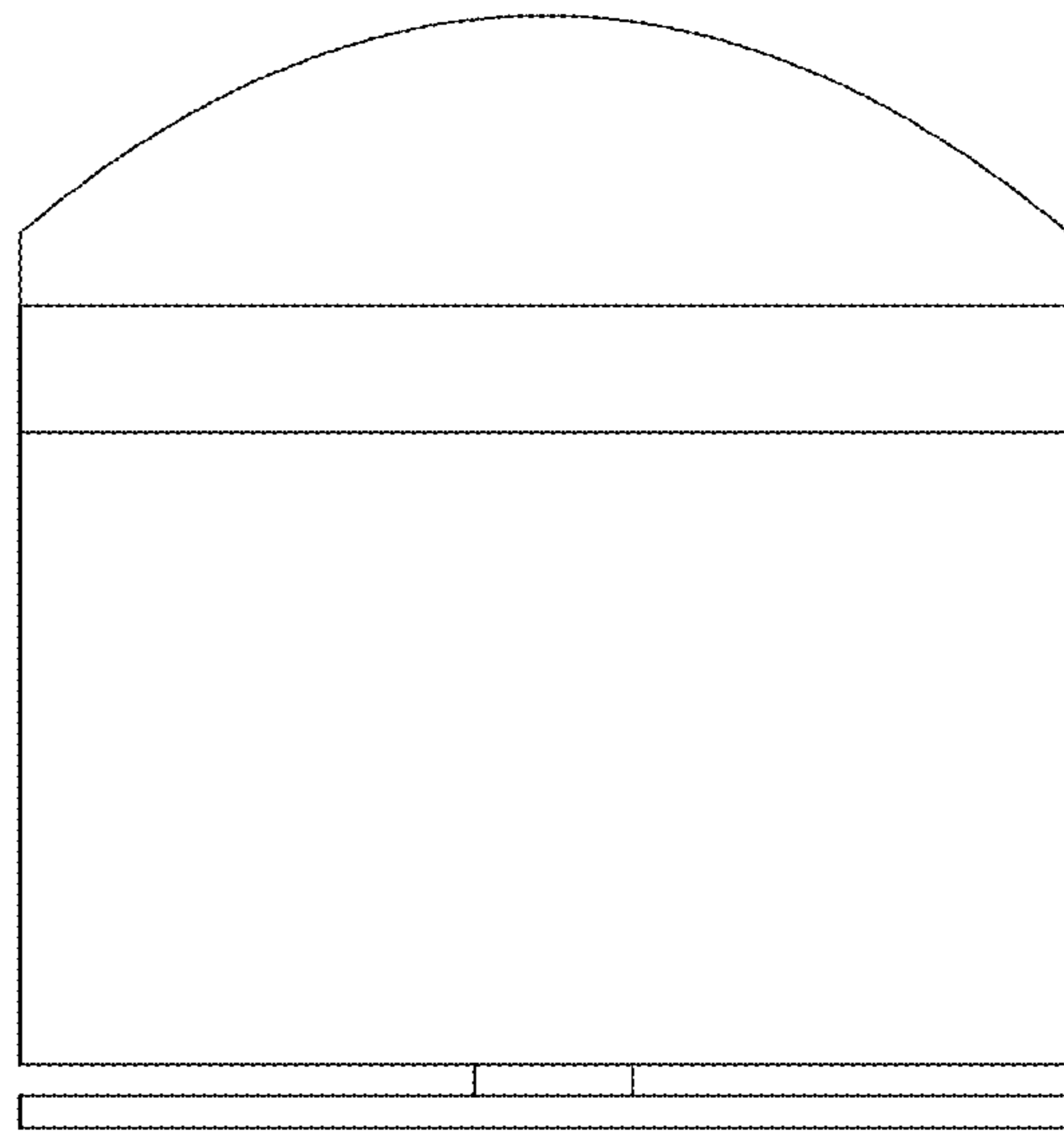

Figure 5



Figure 6

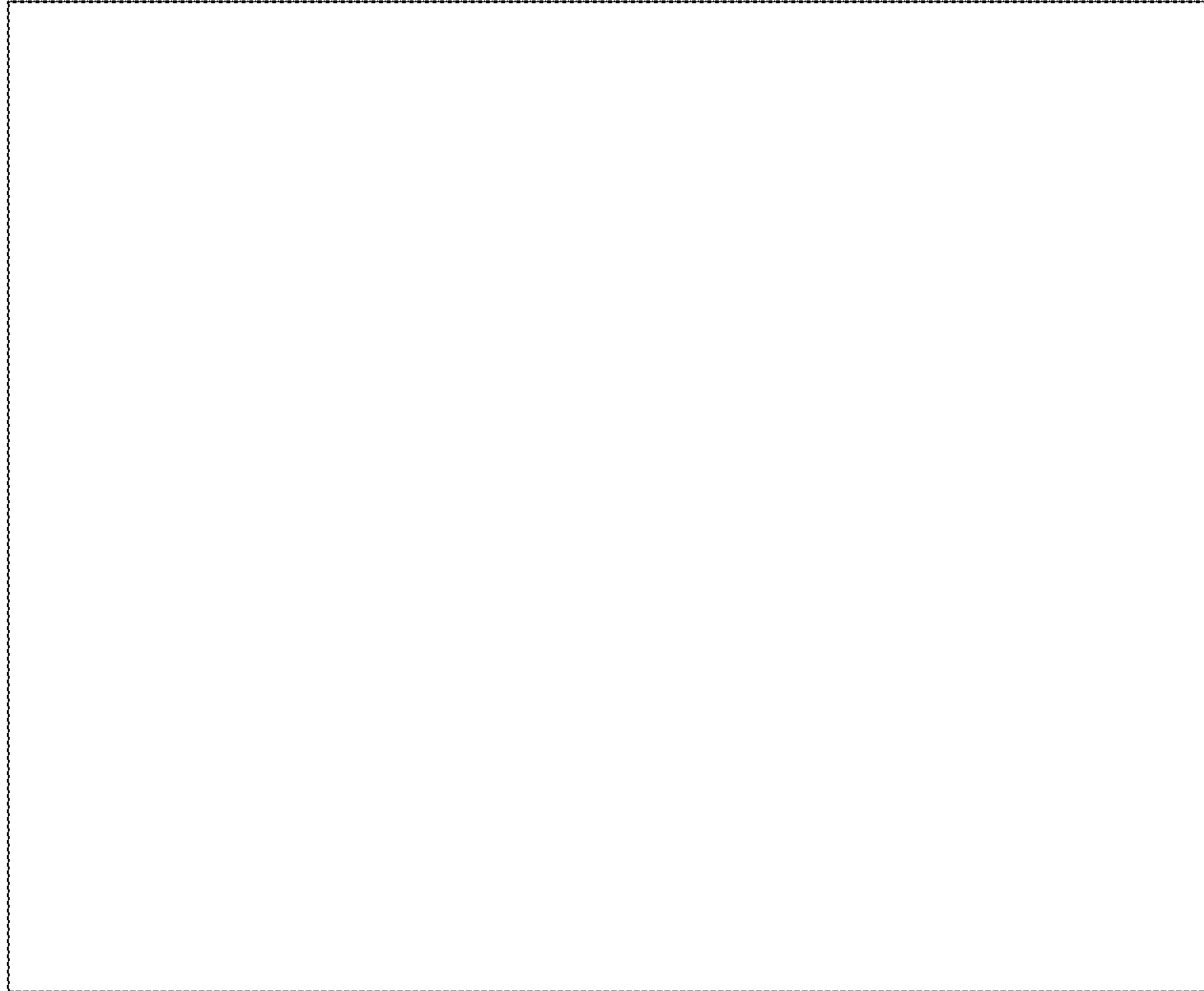

Figure 7